



OIL FIRED UPFLOW FURNACE SPECIFICATIONS

MODEL NO.	OH6FA072D48 / DV4 B			OH6FA072D48 / DV4 R			OH6FA072D48 / DV4 N			OH6FA072D48 / DV4 C		
HEATING CAPACITY	High Fire	Med Fire	Low Fire	High Fire	Med Fire	Low Fire	High Fire	Med Fire	Low Fire	High Fire	Med Fire	Low Fire
HEAT INPUT RATE (BTUH)	106,250	85,000	70,000	106,250	85,000	70,000	106,250	85,000	70,000	106,250	85,000	70,000
OUTPUT BTUH ¹	89,000	72,000	60,000	90,000	73,000	60,000	90,000	71,000	60,000	90,000	71,000	60,000
SEASONAL EFFICIENCY ²	86.0%			86.1%			85.6%			86.0%		
LARGEST REC A/C ³	4 Tons			4 Tons			4 Tons			4 Tons		
NOMINAL TEMP RISE	66°	66°	66°	66°	66°	66°	66°	66°	66°	66°	66°	66°
HEAT EXCHANGER AREA												
CASING HEIGHT (IN.):	45"			45"			45"			45"		
CASING WIDTH (IN.):	20"			20"			20"			20"		
CASING DEPTH (IN.):	30"			30"			30"			30"		
NOMINAL FLUE OUTLET DIA.	5"			5"			5"			5"		
APPROX SHIPPING WEIGHT LBS	250			250			250			250		
APPROVAL STANDARDS	UL727 CAN/CSA B140.4			UL727 CAN/CSA B140.4			UL727 CAN/CSA B140.4			UL727 CAN/CSA B140.4		
QTY AND SIZE OF PERMANENT FILTERS	(1) 24 3/4" X 15 3/4"			(1) 24 3/4" X 15 3/4"			(1) 24 3/4" X 15 3/4"			(1) 24 3/4" X 15 3/4"		
ELECTRICAL REQUIREMENTS VAC/HZ/PH	120/60/1			120/60/1			120/60/1			120/60/1		
MAX FUSE SIZE (AMPS) PSC/ECM	15 / 15			15 / 15			15 / 15			15 / 15		
TOTAL CURRENT (AMPS) PSC/ECM	8.7 / 12.1			8.7 / 12.1			8.7 / 12.1			8.7 / 12.1		
HEIGHT FROM FLOOR TO CENTER OF FLUE	40 3/4"			40 3/4"			40 3/4"			40 3/4"		
SUPPLY AIR OUTLET SIZE (W-IN. X D-IN.)	18" X 19" (20" X 20") ⁵			18" X 19" (20" X 20") ⁵			18" X 19" (20" X 20") ⁵			18" X 19" (20" X 20") ⁵		
RETURN AIR DUCTWORK CONNECTION FLANGE SIZE ON FILTER RACK (D-IN. X H-IN.)	24 1/2" X 15"			24 1/2" X 15"			24 1/2" X 15"			24 1/2" X 15"		
RETURN AIR INLET OPENING SIZE IN SIDE CASING (TO BE CUTOUT BY DEALER) (D-IN. X H-IN.)	23" X 14"			23" X 14"			23" X 14"			23" X 14"		
ACCESSORY ITEMS												
2-LINE SYSTEM KIT FOR RIELLO	N/A			380705			N/A			N/A		
FIELD VENT TERMINATION KIT ⁶	AOPS8393			AOPS8393			AOPS8393			N/A		
SIDEWALL VENT ACCESSORIES KIT ⁶	AOPS8394			AOPS8395			AOPS8412			N/A		
COMBUSTION AIR KIT	AOPS8397			AOPS8416			AOPS8413			N/A		
BLOCKED VENT KIT ⁴	AOPS2686			AOPS2686			AOPS2686			AOPS2686		
OIL BURNER	BECKETT AFG			RIELLO BF3			BECKETT NX			CARLIN EZ-1HP		

¹ OUTPUT BTUH BASED ON ANNUAL FUEL UTILIZATION EFFICIENCY RATED BY MANUFACTURER.

² SEASONAL EFFICIENCY (ALSO CALLED AFUE - ANNUAL FUEL UTILIZATION EFFICIENCY) RATINGS ARE BASED ON TESTS FOLLOWING U.S. DEPARTMENT OF ENERGY TEST PROCEDURES.

³ TO PERMIT LARGEST RECOMMENDED AIR CONDITIONING (AT .5 STATIC PRESSURE), SELECTION OF THE HIGHEST MOTOR SPEED IS REQUIRED.

⁴ NOT TO BE USED IN SIDEWALL VENT APPLICATIONS, USE ONLY WHEN CHIMNEY VENTED.

⁵ PLENUM ADAPTERS INCLUDED WITH UNIT MUST BE INSTALLED FOR 20"X20" PLENUM.

⁶ NOT TO BE USED WITH CARLIN BURNER.

Model Number Digit	1	2	3	4	5	6	7	8	9	10	11	12
	Fuel	Configuration	Heat Exchanger Identifier	Flue	Design Change	Capacity	Capacity	Capacity	Blower Type	Clg Airflow Cap.	Clg Airflow Cap.	Burner
Oil Furnace Model Nomenclature Example Model Numbers	O	H	6	F	A	0	7	2	D	4	8	B
	O	H	6	F	A	0	7	2	D	V	4	R
O = Oil	O											
H = Highboy		H										
6 = Heat Exchanger Size Identifier			6									
F = Front				F								
Design Change					A							
Heating Capacity MBTUH (000's) with factory installed nozzle						0	7	2				
D = Direct Drive									D			
Clg. Airflow: Example = 48MBTUH = 4 tons @ 400cfm/ton										4	8	
Clg. Airflow Variable Speed (ECM) V4= 4tons										V	4	
B = Beckett, R = Riello, N = Beckett NX, C = Carlin												B

- SEE NEXT PAGE FOR MORE DATA -

OIL FIRED UPFLOW FURNACE SPECIFICATIONS

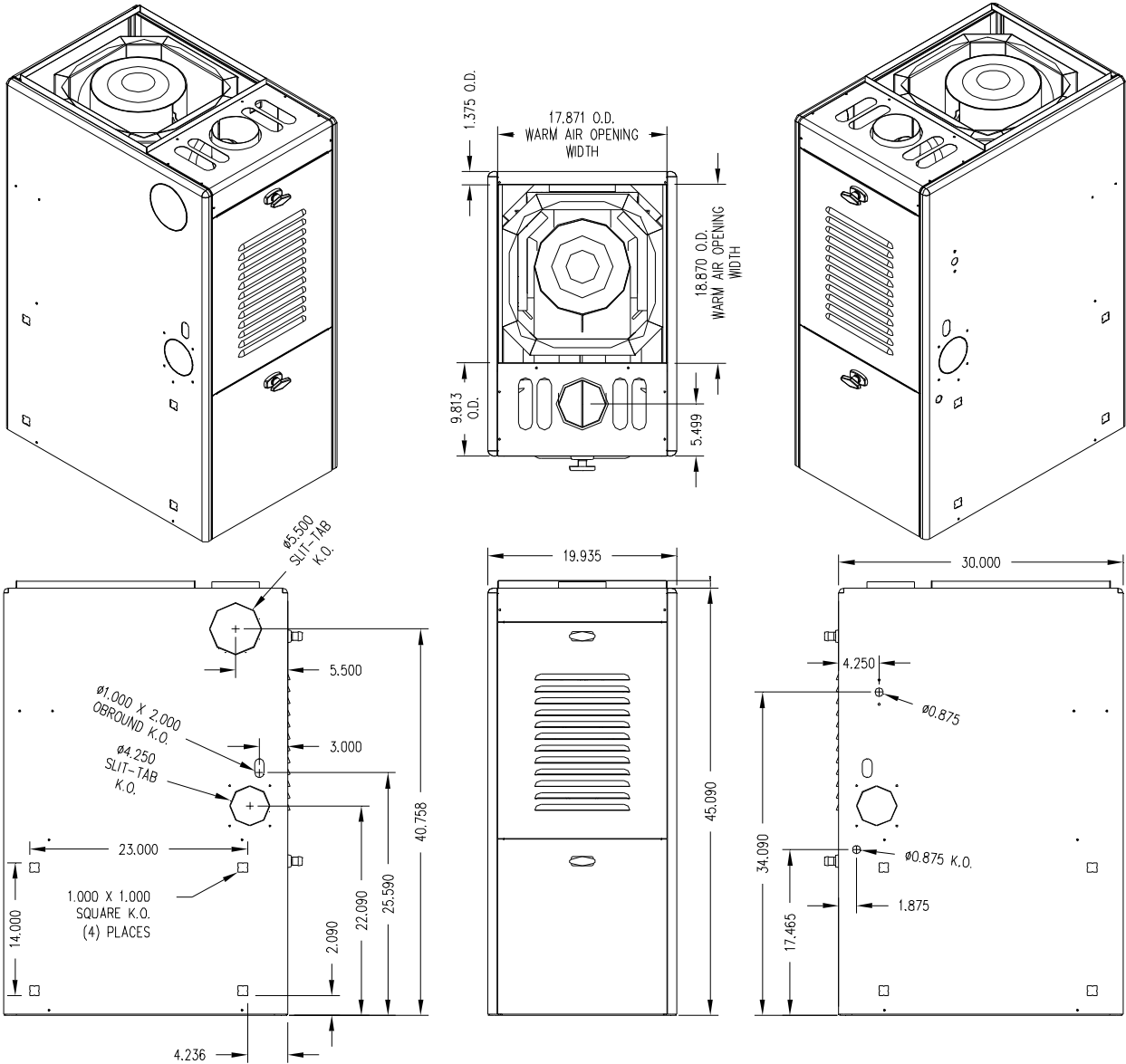

FILTER RACK SPECIFICATIONS

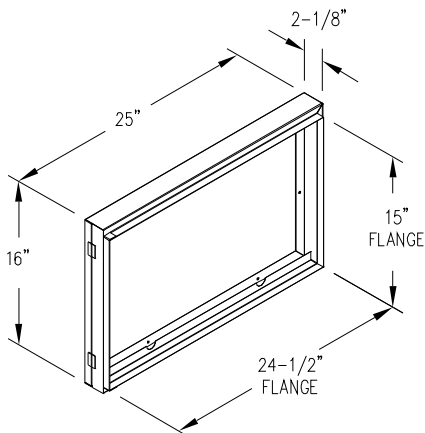

CLEARANCES	
	MINIMUM CLEARANCES TO COMUSTIBLE MATERIALS:
SIDES	0"
FRONT (SERVICE ACCESS)	(Clearance to Combustibles) 6"/ 24" (Service)
REAR	0"
FLUE	7"
TOP PLENUM	1"
SIDES PLENUM	1"

- SEE NEXT PAGE FOR MORE DATA -

OIL FIRED UPFLOW FURNACE SPECIFICATIONS

BLOWER DATA:	OH6FA072D48	OH6FA072DV4
BLOWER MODEL DIRECT DRIVE	DD 100-9R	DD 100-9R
MOTOR H.P.	½ HP	¾ HP Variable Speed
MOTOR TYPE & NUMBER OF SPEEDS	PSC - 4	ECM -
HIGH SPEED AIRFLOW (SCFM) @ 0.5 IN. W.G. EXTERNAL STATIC PRESSURE:	1569	1600
Diameter x Width (IN.)	10 x 9	10 x 9

BURNER DATA	RIELLO "BF3" WITH CERA-FELT SLEEVE		
AIR TUBE LENGTH (IN.)	4 ½"		
BURNER HEAD TYPE:	Fixed		
FUEL TYPE:	#2		
NOZZLE RATING (GPH):	.70	.60	.50
SPRAY ANGLE (DEG.):	80°	80°	80°
SPRAY PATTERN:	HOLLOW (A)	HOLLOW (A)	HOLLOW (A)
OIL PUMP PRESSURE (PSIG):	140 PSI		
COMBUSTION CHAMBER TYPE:	REFRACTORY (SOFT CHAMBER)		

BURNER DATA	BECKETT "AFG" S - PLATE 3912 (3 5/8") 31517 CERAMIC		
AIR TUBE LENGTH (IN.)	4 ½"		
BURNER HEAD TYPE:	F-3		
FUEL TYPE:	#2		
NOZZLE RATING (GPH):	.75	.60	.50
SPRAY ANGLE (DEG.):	80°	80°	80°
SPRAY PATTERN:	SOLID (B)	SOLID (B)	SOLID (B)
OIL PUMP PRESSURE (PSIG):	120 PSI		
COMBUSTION CHAMBER TYPE:	REFRACTORY (SOFT CHAMBER)		

BURNER DATA	BECKETT "NX" w/ NX50LGHS TUBE COMBINATION		
AIR TUBE LENGTH (IN.)	4 ½"		
BURNER HEAD TYPE:	FIXED		
FUEL TYPE:	#2		
NOZZLE RATING (GPH):	.60	.50	.40
SPRAY ANGLE (DEG.):	70°	70°	70°
SPRAY PATTERN:	HOLLOW (A)	HOLLOW (A)	HOLLOW (A)
OIL PUMP PRESSURE (PSIG):	150 PSI		
COMBUSTION CHAMBER TYPE:	REFRACTORY (SOFT CHAMBER)		

BURNER DATA	CARLIN "EZ-1HP"		
AIR TUBE LENGTH (IN.)	4 ½"		
BURNER HEAD TYPE:	N/A		
FUEL TYPE:	#2		
NOZZLE RATING (GPH):	.75	.60	.50
SPRAY ANGLE (DEG.):	60°	60°	60°
SPRAY PATTERN:	HOLLOW (A)	HOLLOW (A)	HOLLOW (A)
OIL PUMP PRESSURE (PSIG):	120 PSI		
COMBUSTION CHAMBER TYPE:	REFRACTORY (SOFT CHAMBER)		

- SEE NEXT PAGE FOR MORE DATA -

OIL FIRED UPFLOW FURNACE SPECIFICATIONS

OH6FA072D48

ALTERATIONS REQ'D FOR A/C @ DESIGN EXTERNAL STATIC PRESSURE				
COOLING UNIT	HTG Speed by Input			Recommended CLG Speed
	Low Fire	Mid Fire	High Fire	
24,000	Low	ML	MH	Low
30,000	Low	ML	MH	Med Low
36,000	Low	ML	MH	Med High
42,000	Low	ML	MH	Med High
48,000	Low	ML	MH	High

Speed Tap\ Static Pressure	Furnace Airflow (CFM) vs. External Static pressure (in. WC.)						
	0.1	0.2	0.3	0.4	0.5	0.6	0.7
Low	930	915	912	910	822	774	730
ML	1155	1152	1130	1126	1085	1042	920
MH	1442	1432	1418	1382	1334	1293	1230
High	1802	1762	1705	1635	1569	1493	1428
Blower Motor Current Draw (Amps) vs. External Static pressure (in. WC.)							
Low	3.28	3.1	3.02	2.91	2.64	2.49	2.36
ML	4.18	4.02	3.91	3.74	3.59	3.34	2.95
MH	5.44	5.17	4.95	4.72	4.43	4.21	3.95
High	6.61	6.36	6.04	5.73	5.46	5.17	4.9

Speed Tap\ Static Pressure	High Fire Temperature Rise vs. External Static pressure (in. WC.)						
	0.1	0.2	0.3	0.4	0.5	0.6	0.7
Low	90	91	91	92	101	108	114
ML	72	72	74	74	77	80	91
MH	58	58	59	60	62	64	68
High	46	47	49	51	53	56	58

Speed Tap\ Static Pressure	Mid Fire Temperature Rise vs. External Static pressure (in. WC.)						
	0.1	0.2	0.3	0.4	0.5	0.6	0.7
Low	72	73	73	73	81	86	91
ML	58	58	59	59	61	64	72
MH	46	47	47	48	50	52	54
High	37	38	39	41	42	45	47

Speed Tap\ Static Pressure	Low Fire Temperature Rise vs. External Static pressure (in. WC.)						
	0.1	0.2	0.3	0.4	0.5	0.6	0.7
Low	60	61	61	61	68	72	76
ML	48	48	49	49	51	53	60
MH	39	39	39	40	42	43	45
High	31	32	33	34	35	37	39

OIL FIRED UPFLOW FURNACE SPECIFICATIONS

OH6FA072DV4

Heating Speed Set-ups

		Low Fire	Med Fire	High Fire	Static Pressure (Amps/Watts)		
		60,000	72,000	90,000			
		BTUH	Aprox. Rise (F°)	Aprox. Rise (F°)	Aprox. Rise (F°)		
Fan Control SW 1 Switch Settings	Heating CFM				0.2	0.5	
3-OFF 2-OFF 1-OFF	740	75°			1.1/98	1.8/173	
3-OFF 2-OFF 1-ON	812	68°	82°		1.3/114	2.1/193	
3-OFF 2-ON 1-OFF	883	63°	76°		1.5/129	2.4/218	
Factory SW1 Switch Settings 3-OFF 2-ON 1-ON	968	57°	69°	86°	1.7/148	2.4/223	
3-ON 2-OFF 1-OFF	1054		63°	79°	1.9/173	2.7/246	
3-ON 2-OFF 1-ON	1153		58°	72°	2.3/207	3.0/283	
3-ON 2-ON 1-OFF	1267			66°	2.7/247	3.5/332	
3-ON 2-ON 1-ON	1424			58°	3.4/315	4.3/409	

 = Recommended Heating Speed Setting

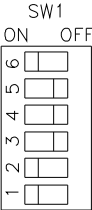

OIL FIRED UPFLOW FURNACE SPECIFICATIONS

OH6FA072DV4

Cooling Speed Set-ups

		Air Flow		Static Pressure (Amps/Watts)	
Fan Control SW 1 Switch Settings	Clg. Tonage	Cool	Continuous	0.2	0.5
6-OFF 5-OFF 4-OFF	2	799	500	1.2/109	2.1/186
6-OFF 5-OFF 4-ON	2.5	1017	508	1.8/160	2.5/230
6-OFF 5-ON 4-OFF	3	1210	605	2.4/220	3.3/308
6-OFF 5-ON 4-ON	3.5	1404	702	3.2/305	4.2/409
Factory SW1 Switch Settings 6-ON 5-OFF 4-OFF	4	1622	799	4.6/443	5.7/560

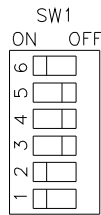

- SEE NEXT PAGE FOR MORE DATA -

A/C Evaporator Coil Applications

Furnace Model Number	AC Tonnage	Line Set	Cond. Model Number	Coil Model Number	Capacity	EER	SEER	AHRI Reference Number
OH6FA072D48 OH6FA072DV4	2	LS01E-30	TC4B2422S	HE33636PA212	23000	12.20	14.00	9136135
				HE47636PA212	23000	12.20	14.50	9136136
		LS01E-50	TC7B2421S	HE33636PA212	23600	12.50	15.00	9136145
				HE47636PA212	23600	13.00	16.00	9136146
	2.5	LS01E-30	TC4B3022S	HE33636PA212	29400	11.70	14.00	9136137
				HE47636PA212	29400	12.20	14.50	9136138
		LS01E-50	TC7B3021S	HE33636PA212	28000	12.50	15.00	9136147
				HE47636PA212	28400	13.00	16.00	9136148
	3	LS01E-30	TC4B3622S	HE33636PA212	34400	11.70	14.00	9136139
				HE47636PA212	34600	12.20	14.50	9136140
		LS01E-50	TC7B3621S	HE33636PA212	34800	12.20	15.00	9136149
				HE47636PA212	36000	13.00	16.00	9136150
	3.5	LS02E-30	TC7B4221S	-	-	-	-	-
				HE50660PA212	41500	13.00	16.00	9136152
	4	LS02E-30	TC4B4821H	-	-	-	-	-
				HE50660PA212	47500	12.20	14.50	9136144
		LS02E-50	TC7B4821S	-	-	-	-	-
				HE50660PA212	45500	12.50	15.00	9136154