



**OIL FIRED FURNACE  
INSTALLATION AND OPERATION MANUAL  
WITH USERS INFORMATION SECTION**

**MODEL:**

**OL6RA072D48(B/R/C)  
OL6RA072DV5(B/R/C)**

**OL6FA072D48(B/R/C)  
OL6FA072DV5(B/R/C)**

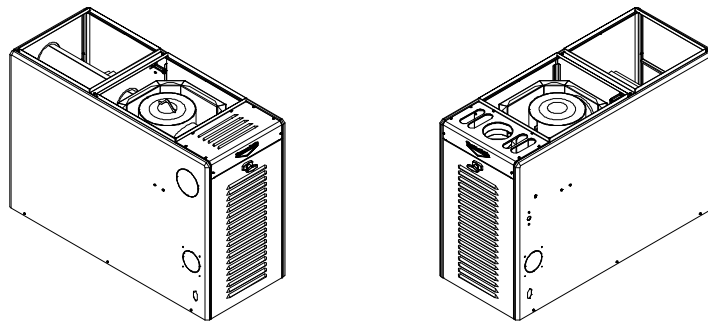

**⚠ WARNING:** IF THE INFORMATION IN THESE INSTRUCTIONS IS NOT FOLLOWED EXACTLY, A FIRE OR EXPLOSION MAY RESULT CAUSING PROPERTY DAMAGE, PERSONAL INJURY, OR LOSS OF LIFE.

DO NOT STORE OR USE GASOLINE OR OTHER FLAMMABLE VAPORS AND LIQUIDS IN THE VICINITY OF THIS OR ANY OTHER APPLIANCE.

**⚠ WARNING:** IMPROPER INSTALLATION, ADJUSTMENT, ALTERATION, SERVICE, OR MAINTENANCE CAN CAUSE INJURY OR PROPERTY DAMAGE. REFER TO THIS MANUAL. FOR ASSISTANCE OR ADDITIONAL INFORMATION CONSULT A QUALIFIED INSTALLER, OR SERVICE AGENCY.

**PLEASE READ THESE INSTRUCTIONS PRIOR TO INSTALLATION, INITIAL FIRING, AND BEFORE PERFORMING ANY SERVICE OR MAINTENANCE. THESE INSTRUCTIONS MUST BE LEFT WITH THE USER AND SHOULD BE RETAINED FOR FUTURE REFERENCE BY QUALIFIED SERVICE PERSONNEL.**

THERMO PRODUCTS, LLC.  
PO BOX 237  
DENTON, NC 27239  
PHONE: 800-476-4328



MO-483  
ECN 5587-MA 190812



**Intertek**

Made IN USA



## CONTENTS

<u>SECTION</u>	<u>PAGE</u>
I. SAFETY SECTION.....	1
A. CODES AND CLEARANCES.....	4
B. MAKE-UP AIR.....	5
II. GENERAL INSTRUCTIONS.....	6
A. CHIMNEY.....	7
B. VENTING.....	11
C. DRAFT REGULATORS.....	12
D. DUCT WORK/AIR CONDITIONING.....	12
E. AIR FILTER(S).....	16
F. LIMIT POSITION AND LOCATION.....	17
G. BURNER INSTALLATION.....	18
H. BURNER SPECIFICATIONS AND APPLICATIONS.....	19
I. OILTANK AND PIPING.....	20
J. OIL FILTER.....	21
K. ELECTRICAL WIRIING.....	21
L. BLOWER SETUP.....	25
M. BLOWER CONTROLLER INFORMATION FOR PSC MOTOR.....	29
N. STARTUP PROCEDURES.....	34
III. USERS INFORMATION SECTION.....	40
A. OIL SUPPLY.....	40
B. COMBUSTION AIR SUPPLY.....	40
C. INSPECTION AREAS.....	40
D. STARTING THE BURNER.....	41
E. FILTER CLEANING AND LOCATION.....	41
IV. INSTALLER'S INSTRUCTIONS TO USER.....	42
V. DEALER MAINTENANCE.....	43
A. GENERAL INSPECTION.....	43
B. HEAT EXCHANGER.....	44
C. HEAT EXCHANGER CLEANING INSTRUCTIONS.....	44
D. ELECTRICAL SYSTEM.....	46
E. SUPPLY/RETURN AIR BLOWER.....	46
F. SUPPLY/RETURN AIR FILTER.....	46
G. EXTENDED APPLIANCE SHUTDOWN.....	47
VI. HOMEOWNER/USER INFORMATION AND ROUTINE MAINTENANCE.....	49
VII. TROUBLESHOOTING.....	51
A. DIAGNOSTICS.....	51
B. CAD CELL CHECK-OUT PROCEDURE.....	51
VIII. SEQUENCE OF OPERATIONS FLOW CHART.....	52
IX. TROUBLE SHOOTING FLOW CHART.....	54
APPENDIX – A	
REPLACEMENT PARTS LIST.....	60
APPENDIX – B	
WIRING DIAGRAMS.....	67



Model Number Digit	1	2	3	4	5	6	7	8	9	10	11	12
	Fuel	Configuration	Heat Exchanger Identifier	Flue	Feature	Capacity	Capacity	Capacity	Blower Type	Cig Airflow Cap.	Cig Airflow Cap.	Burner
<b>Oil Furnace Model Nomenclature Example Model Numbers</b>	O	L	6	F	A	0	7	2	D	4	8	B
	O	L	6	F	A	0	7	2	D	V	5	B
	O	L	6	F	X	0	7	2	D	V	5	R
	O	L	6	R	A	0	7	2	D	4	8	R
<b>O = Oil</b>	O											
<b>H = Highboy D = Downflow L= Lowboy</b>		L										
<b>6 = Heat Exchanger Size Identifier</b>			6									
<b>F = Front</b>				F								
<b>R = Rear</b>				R								
<b>A = Single Stage</b>					A							
<b>Heating Capacity MBTUH (000's) with factory installed nozzle</b>						0	7	2				
<b>D = Direct Drive</b>									D			
<b>Cig. Airflow: Example = 48MBTUH = 4 tons @ 400cfm/ton</b>										4	8	
<b>Cig. Airflow Variable Speed (ECM) V5 = 5tons</b>										V	5	
<b>B = Beckett, R = Riello, C = Carlin</b>												B

## I. SAFETY SECTION

This page and the following contains various warnings and cautions found throughout the Oil Furnace Manual. Please read and comply with the statements below.

### **⚠WARNING AND CAUTIONS:**

**⚠WARNING:** This furnace is not to be used as a construction heater. **See Page 4**

**⚠WARNING:** The predetermined limit locations on all of the Thermo Pride oil fired furnaces have been tested and approved by Thermo Products, LLC. Any attempt to relocate these safety controls or replace these safety controls with a control that is not approved, or is incompatible, may result in personal injury, substantial property damage or death. **See Page 17**

**⚠WARNING:** **THE HEAT EXCHANGER MUST BE CLEANED BY A QUALIFIED SERVICE PERSON.** **See Page 49**

**⚠CAUTION:** **DO NOT ATTEMPT TO MAKE REPAIRS YOURSELF!** **See Page 45**

**⚠WARNING:** The area around the furnace should be kept free and clear of combustible liquids and material, especially papers and rags. **See Page 4**

**⚠WARNING:** **NEVER** burn garbage or refuse in your furnace. Never try to ignite oil by tossing burning papers or other material into your furnace. **See Page 45**

**⚠WARNING:** Thermo Products oil furnaces are designed to burn No. 1 or No. 2 distillate fuel oil. Bio fuel blend up to 5% (B5) is permissible.  
**NEVER USE GASOLINE OR A MIXTURE OF OIL AND GASOLINE.** **See Page 45**

**⚠CAUTION:** **DO NOT ATTEMPT TO START THE BURNER WHEN:**

1. Excess oil has accumulated,
2. The furnace is full of vapors
3. The combustion chamber is very hot.

**IF ONE OR MORE OF THESE CONDITIONS EXIST, CONTACT A QUALIFIED SERVICE PERSON.** **See Page 45**

**⚠WARNING:** **DO NOT START BURNER UNLESS BLOWER DOOR IS SECURED IN PLACE.**

## ▲WARNING

### ANNUAL SERVICE REQUIRED

The following items should be inspected every year by a qualified heating servicer. (Shut off power before inspecting.) Correct any deficiencies at once. Failure to do so may result in injury, property damage or loss of life.

Heat Exchanger: Inspect for corrosion, pitting, warpage, cracks, deterioration, carbon build up and loose gaskets.

Burner: Check for correct operation, proper combustion, no fuel leakage, and replace burner oil filter.

Chimney/Vent Pipe: Inspect for restriction, loose joints, abnormal carbon build up and condensation.

Controls: Check for correct operation and proper settings. (if manually adjustable).

Periodic visual inspections should also be made by the owner during the heating season. Call a qualified heating servicer to report suspected deficiencies. (Do not attempt to make repairs yourself!)

Further owner and heating servicer responsibilities are detailed in the printed information provided with the furnace.

## ▲AVERTISSEMENT

### ENTRETIEN ANNUEL NÉCESSAIRE

Les composants suivants doivent être inspectés chaque année par un technicien en chauffage qualifié. (Couper l'alimentation électrique avant l'inspection.) Corriger immédiatement tous les défauts. Le non-respect de cette consigne pourrait causer des dommages matériels, des blessures ou même la mort.

Échangeur de chaleur: Vérifier la présence de corrosion, piqûres, fissures, détérioration, calamine et joints dégradés.

Brûleur: Vérifier le fonctionnement correct, la combustion, l'absence de fuite de combustible et remplacer le filtre à mazout du brûleur.

Cheminée/tuyau d'évacuation: Vérifier la présence de restrictions, joints dégradés, accumulation anormale de calamine et condensation.

Commandes: Vérifier le fonctionnement et les réglages (s'ils sont manuels).

Le propriétaire devra également effectuer des inspections visuelles périodiques pendant la saison de chauffage. Appelez un technicien qualifié en chauffage pour l'informer de défauts éventuels. (N'essayez pas de réparer vous-même!)

Les autres responsabilités du propriétaire et du technicien en chauffage sont détaillées dans les renseignements imprimés fournis avec la fourniture.

## ▲WARNING

This compartment must be closed except when servicing.

## ▲AVERTISSEMENT

Ce compartiment doit être fermé sauf pendant l'entretien.

## ▲CAUTION

### RESEAL HEAT EXCHANGER ACCESS PORTS

Clean outs accessible by qualified service personnel only. Access to clean out may require removal of panel. Be certain clean out covers and/or gaskets are intact and in proper position to ensure complete seal prior to operation.

Failure to do so may result in property or equipment damage.

## ▲ATTENTION

### REBOUCHER LES ORIFICES D'ACCÈS À L'ÉCHANGEUR DE CHALEUR

Regards de visite accessibles uniquement au personnel d'entretien qualifié. L'accès aux regards de visite peut nécessiter la dépose du panneau. Vérifier que les couvercles et/ou joints des regards de visite sont en bon état et bien en place pour assurer l'étanchéité avant d'utiliser la fournaise.

Le non-respect de cette consigne peut provoquer des dommages matériels ou la détérioration de l'équipement.

## ▲CAUTION

### ROTATING FAN BLADE!

To avoid injury from hot or moving parts, shut off the furnace and allow to cool before removing this door.

When it becomes necessary to replace or wash filter, remove the dirty filter from the racks provided and wash or replace with identical new filters.

The blower motor located behind this door may or may not require lubrication. If lubrication instructions are not shown on the motor nameplate, the motor should not be lubricated. If the nameplate indicates that the motor requires lubrication, lubricate the motor as directed or use 30 drops of SAE 20 weight oil or equivalent twice a year. Do not use a light household grade oil.

## ▲ATTENTION

### PALE DE VENTILATEUR EN ROTATION!

Pour éviter d'être blessé par des pièces chaudes ou en rotation, arrêter la fournaise et attendre qu'elle refroidisse avant de retirer cette porte.

Quand il devient nécessaire de remplacer ou de laver le filtre, retirer le filtre sale des supports prévus et le laver ou le remplacer par un filtre neuf identique.

Le moteur de soufflerie situé derrière cette porte peut ou non avoir besoin de lubrification. S'il n'y a pas d'instructions de lubrification sur la plaque signalétique du moteur, celui-ci ne doit pas être lubrifié. Si la plaque signalétique indique que le moteur a besoin d'être lubrifié, le lubrifier comme indiqué ou utiliser 30 gouttes d'huile SAE 20 ou équivalente deux fois par an. Ne pas utiliser d'huile domestique légère.

## ▲WARNING

### SPECIAL HOMEOWNERS INSTRUCTIONS

Improper installation, adjustment, alteration, service or maintenance can cause injury or property damage. Refer to the user's information section in the manual. For assistance or additional information consult a qualified installer, service agency or the gas/oil supplier.

## ▲AVERTISSEMENT

### INSTRUCTIONS SPÉCIALES POUR PROPRIÉTAIRES

Des erreurs dans l'installation, le réglage, les modifications, les réparations ou la maintenance peuvent entraîner des blessures ou des dommages matériels. Se référer à la section relative aux renseignements pour l'utilisateur du présent manuel. Pour toute assistance ou renseignement complémentaire, consulter un installateur qualifié, une agence de service ou le fournisseur de gaz/mazout.

## ▲WARNING

### REINSTALL ALL PARTS!

Should this unit be disassembled all components, panels, block offs, collars, gaskets, and fasteners must be reassembled as originally factory produced.

Failure to do so may result in property damage, injury, or loss of life.

## ▲AVERTISSEMENT

### REMONTER TOUTES LES PIÈCES!

En cas de démontage de cet appareil, tous les composants, panneaux, obturations, colliers, joints et fixations doivent être remontés comme à l'origine.

Le non-respect de cette consigne pourrait causer des dommages matériels, des blessures ou même la mort.

**⚠ WARNING**

**HAZARDOUS VOLTAGE**  
 Avoid contact with exposed live voltage terminals. Do not bypass or disconnect limit. Turn off power prior to service.

Failure to do so may result in property damage, injury, or loss of life.



**WARNING:** This product can expose you to chemicals, including Chromium, which are known to the state of California to cause cancer and birth defects or other reproductive harm. For more information go to [www.P65Warnings.ca.gov](http://www.P65Warnings.ca.gov).



**AVERTISSEMENT:** Ce produit peut vous exposer à des produits chimiques, y compris le chrome, qui sont connus dans l'état de Californie pour causer le cancer et des malformations congénitales ou d'autres problèmes de reproduction. Pour plus d'informations, visitez [www.P65Warnings.ca.gov](http://www.P65Warnings.ca.gov).

**⚠ AVERTISSEMENT**

**TENSIONS DANGEREUSES**  
 Éviter le contact avec les terminaux de tension à l'état exposée. Ne pas contourner ou se déconnecter de limite. Coupez courant avant de service.

Omission de le faire peut entraîner perte de vie, des blessures ou des dommages à la propriété.

390350

**⚠ WARNING**

**PROFESSIONAL INSTALLATION AND SERVICE REQUIRED!**  
 This unit must be installed and serviced by a qualified service. Failure to do so may result in property damage, injury, or loss of life.

**⚠ AVERTISSEMENT**

**INSTALLATION ET RÉPARATION PAR DES PROFESSIONNELS UNIQUEMENT!**  
 Cet appareil doit être installé et réparé par un technicien d'entretien qualifié. Le non-respect de cette consigne pourrait causer des dommages matériels, des blessures ou même la mort.

390294



Intertek

2000980



MODEL NO. **OL6FA072D48**

SERIAL NO. **00000000**

**OIL FIRED FURNACE**

CERTIFIED TO UL STD 727 · CAN/CSA STD B140.4

FOR USE ONLY WITH R.W. BECKETT OIL BURNER MODEL AFG TP-2501, CARLIN EZ-1HP OR RIELLO OIL BURNER MODEL BF3 C8511325.

ID	INPUT BTU/HR	OUTPUT BTU/HR	-B BECKETT AFG -C CARLIN NOZ/GPH/TYPER	-R RIELLO NOZ/GPH/TYPER	CO2 FOR MAX AFUE
-60	70,000	60,000	0.50 80°B 0.50 60°A	0.50 80°A	10% - 11%
-72+	85,000	72,000	0.60 80°B 0.60 60°A	0.60 80°A	11% - 11½%
-90	106,250	90,000	0.75 80°B 0.75 60°A	0.70 80°A	12% - 13%
			PUMP PRESS 120 PSI 120 PSI 140 PSI		

+ FACTORY EQUIPPED NOZZLE. USE NO. 2 (DISTILLATE) FUEL OIL.  
 FOR MAXIMUM EFFICIENCY (AFUE) SET THE BURNER COMBUSTION AS INDICATED IN THE CHART ABOVE. DO NOT EXCEED A TRACE SMOKE SPOT AND A 66°F TEMPERATURE RISE.

ELECTRICAL SPECIFICATIONS 120 VOLTS 60 HZ 1 PHASE  
 TOTAL CURRENT (AMPS) 8.7  
 MINIMUM CIRCUIT AMPACITY 10.25  
 MAXIMUM FUSE SIZE (AMPS) 15

390425 (03/16-5587) -NA  
 1010-61 5587 -NA

**THERMO PRODUCTS, LLC.**  
 P.O. BOX 237 DENTON, NC 27239

DIRECT DRIVE BLOWER  
 EXTERNAL STATIC PRESSURE (INCHES W.C.) 0.20 TO 0.50  
 MAXIMUM DESIGNED OUTLET AIR TEMPERATURE 180°F OR LESS

FOR INSTALLATION IN A CLOSET OR ALCOVE ON NON-COMBUSTIBLE FLOORING WITH CLEARANCES TO UNPROTECTED COMBUSTIBLE MATERIAL NOT LESS THAN:

ANY SIDE OF SUPPLY PLENUM (INCHES)	TOP	SIDES	REAR	FRONT	FLUE PIPE
1	1	0	0*	6*	7

\* 24 INCHES FOR SERVICE PURPOSES  
 CLOSET INSTALLATION REQUIRES TWO SEPARATE VENTILATION OPENINGS LOCATED 6 INCHES FROM THE TOP AND BOTTOM OF THE CLOSET DOORS OR PANELS MEASURING NO LESS THAN 17 INCHES WIDE BY 8-1/2 INCHES HIGH.

390425 (03/16-5587) -NA  
 1010-61 5587 -NA



**The entire text of these instructions must be read and understood, before installing the appliance. It is the installer's responsibility to do the following:**

1. Inform and demonstrate to the user, the correct operation and maintenance of the appliance, as explained in the **Homeowner/User Information and Routine Maintenance** section of this manual.
2. Inform the user of the hazards of flammable liquids and vapors and to remove such liquids and vapors from the vicinity of the appliance.
3. Inform the user of all pertinent warnings and precautions concerning this appliance.
4. It is recommended that a commercially available CO alarm be installed in conjunction with any fossil fuel burning appliance. The CO alarm shall be installed according to the alarm manufacturer's installation instructions and be listed in accordance with latest edition of the UL Standard for Single and Multiple Station Carbon Monoxide Alarms, UL 2034, or the CSA International Standard, Residential Carbon Monoxide Alarming Devices, CSA 6.19.

**⚠WARNING: This unit is not to be used for temporary heating of buildings, or structures, under construction.** Construction dust may enter the appliance or the duct system and cause a fire hazard. Certain chemicals used during construction when burned, form corrosive condensate that can substantially reduce the life of the heating system heat exchanger.

This appliance is shipped completely assembled and internally wired. All electrical wiring has been factory installed and inspected. At the time of installation, the unit will require connection to electric power, fuel oil supply, and supply and return air ductwork. In the event of a shortage of parts or damage, contact Thermo Pride office.

This unit uses a fan-assisted combustion system, consisting of a pressure atomizing, oil burner and combustion air blower, used to push the products of combustion through the heat exchanger system. After installation, the furnace and duct system must be adjusted to obtain a temperature rise of 50°F to 80°F through the unit. The return air temperature must be above 55°F to prevent condensation of flue products in the heat exchanger. (Refer to the rating label located on side panel inside the burner compartment). The installation must conform with local codes or, in the absence of local codes, with the Standard for the Installation of Oil-Burning Equipment, NFPA 31-1997, or the latest edition, and to these instructions. The installation must also comply with CSA B139 for recommended installation practices where applicable.

## **A. CODES AND CLEARANCES:**

The following items must be considered when choosing the size and location of the unit.

1. **All local codes and/or regulations take precedence over the instructions in this manual and should be followed accordingly.** In the absence of local codes, installation must conform to these instructions and the guidelines of the National Fire Protection Association (NFPA). Two applicable NFPA installation codes are the National Electrical Code, ANSI/NFPA 70-1999, and Standard for the Installation of Oil-Burning Equipment, NFPA 31-1997. The latest editions of these codes should be consulted.
2. The selection of a heating unit should be based on a rate of heat loss calculation for the residence according to the manuals provided by the Air Conditioning Contractors of America (ACCA) or the American Society of Heating, Refrigeration, and Air Conditioning Engineers (ASHRAE). The heating capacity of the unit proposed for installation should meet or slightly exceed the rate of heat loss for the residence. Over sizing should not exceed 25% of the heat loss calculation.
3. When installed, this unit should be level. If possible, it should be installed in a central location, with respect to outlet registers of the supply air ductwork.

4. Definitions of "combustible" and "non-combustible" materials as presented in the 1996 version of the National Fuel Gas Code, ANSI Z223.1-1996/NFPA 70-1996, are as follows:

**a. Combustible material:**

"...materials made of or surfaced with wood, compressed paper, plant fibers, or other materials that are capable of being ignited and burned. Such materials shall be considered combustible even though flame proofed, fire-retardant treated, or plastered."

**b. Non-combustible material:**

"...material that is not capable of being ignited and burned; such as material consisting entirely of, or a combination of, steel, iron, brick, concrete, slate, asbestos, glass, and plaster."

**⚠WARNING: Carefully read and thoroughly understand the following guidelines and warnings before continuing with the installation of this appliance. Failure to follow these guidelines can cause improper and unsafe operation of this appliance. Unsafe operation can result in substantial property damage, severe personal injury, or death.**

1. This appliance shall be used with only the type of fuel oil for which it is approved. Refer to the appliance-rating label for the required type of fuel.
2. This appliance is an oil-fired furnace designed for installation on non-combustible materials. This appliance is also approved for attic installation on non-combustible materials.
3. Ensure that adequate combustion and ventilation air is available to the unit.
4. The airflow resistance of the duct system attached to this appliance must fall within the allowable external static pressure range for this unit. Refer to the **Airflow Requirements and Sizing of Ductwork** section of this manual.
5. Make sure supply and return air ducts are completely sealed to the appliance casing. Refer to the **Airflow Requirements and Sizing of Ductwork** section of this manual.

This area in which the furnace is located must have adequate supply of air for combustion and draft control operation. The minimum required volume of free air should be 50ft<sup>3</sup>/1000 btu (per NFPA 54). However, if the furnace is located in an area of the building that doesn't meet this requirement, two openings into another room are recommended (each opening having a free area of 1 square inches per 1,000 BTUH input of the total input of all appliances located in the room). If these openings are in a wall, they must be at least 6 inches from the ceiling and floor (Fig. 1A) or they are in a door, they must be at least 6 inches from the top of the door and 6 inches from the bottom of the door (Fig. 1B). **THESE OPENINGS MUST BE FREE AND UNOBSTRUCTED.**

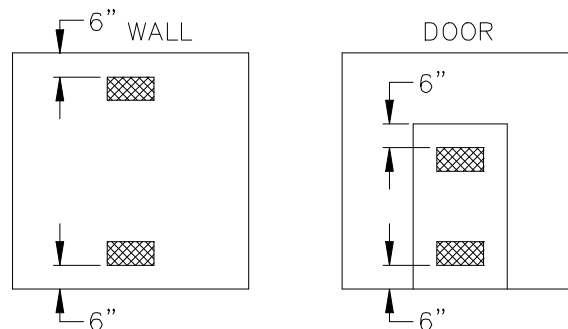

**Fig 1: Properly Positioned Combustion Air Openings In Walls (Fig. 1A) and Doors (Fig. 1B).**

**B. MAKE-UP AIR:** Today's emphasis on home insulation increases the probability of inadequate air supply to the furnace. Heavy insulation cuts off infiltration of outside air, which previously replaced inside air removed by bathroom, kitchen and laundry vent fans, and air escaping up chimneys. This causes a

negative pressure differential within the home that reduces the supply of air available to the furnace for combustion and ventilation.

The Thermo Pride Make-Up-Air Control, installs quickly and easily on any warm air heating system, delivers controlled, fresh air automatically during the winter and a constant supply of clean, fresh air for comfortable summer living. It resolves the negative pressure differential problem.

## II. GENERAL INSTRUCTIONS - READ BEFORE START OF INSTALLATION

1. The heating output capacity of the furnace proposed for installation should be based on a heat loss calculation made according to the manuals provided by the Air Conditioning Contractors of America (ACCA) or the American Society of Heating, Refrigeration and Air Conditioning Engineers, Inc. (ASHRAE).
2. All local codes and/or regulations take precedence over the instructions in this manual and should be followed accordingly. In the absence of local codes, installation must conform with these instructions and regulations of the National Fire Protection Association, and to the provisions of the National Electrical Code (ANSI/NFPA 70-1999 or latest edition).
3. The installed furnace must be level and positioned in a central location with respect to outlet registers. It should be located near the chimney to minimize any horizontal run of flue pipe, which may be required.
4. A furnace installed in a residential garage must be installed so the burner and ignition source are located higher than 18 inches above the floor. The furnace must also be located or protected to avoid physical damage by vehicles.

**⚠WARNING:** This furnace is not to be used as a construction heater.

5. Listed below are definitions of "COMBUSTIBLE MATERIAL" and "NON-COMBUSTIBLE MATERIAL."

**Combustible Material:** is made of or surfaced with wood, compressed paper, plant fibers, plastics, or other material that will ignite and burn, whether flame resistant or not.

**Non-Combustible Material:** is material that is not capable of being ignited and burned. Such materials consist entirely of, or a combination of, steel, iron, brick, tile, concrete, slate, or glass.

Table 1: MINIMUM CLEARANCES TO COMBUSTIBLE MATERIALS

TYPE OF UNIT	MODEL NO.	FROM SIDES OF FURNACE	FRONT	TOP & SIDES OF PLENUM	FROM THE FLUE/VENT	REAR
Lowboy	OL6**072D***	0"	6" ‡	1"	7"	0" ‡

‡ The minimum clearances listed in the preceding table are for fire protection. Clearance for servicing the front and rear of the furnace should be at least 24 inches.

**NOTE:** The OL6 furnace is approved for closet installation. If the furnace is installed in a closet, it requires two openings in the closet door for combustion air, each having a minimum area of 162 sq. inches. This free area intentionally exceeds the recommended minimum free area of 1 square inch per 1000 BTUH of input rate.

## **A. CHIMNEY:**

The furnace must be connected to an adequate chimney or an approved vent in accordance with these instructions. An adequate chimney is one that is sealed and lined with the capability of producing a (-).04" WC flue draft and having the capacity to handle the amount of stack gases that are introduced into it. A chimney with an internal construction of corrosion resistant tile, stainless steel, or some other material that will withstand flue gas temperatures up to 900°F is required.

### **Qualified service personnel must perform all installations and services.**

The following are common chimney requirements necessary for the furnace to operate correctly:

A masonry chimney serving a Thermo Pride oil fired furnace must comply with local codes and NFPA Standard for Chimneys, Fireplaces, Vents, and Solid Fuel Burning Appliances (NFPA211-1996 or latest edition).

#### **1. PREVENTION OF CHIMNEY CONDENSING:**

Stack gas may do one of two things as it escapes up the chimney:

- A. Remain entirely in a gaseous state if the internal chimney wall temperature is above the dew point
- B. Condense water vapor on the chimney walls if they are chilled below the dew point.

Condensing will always occur on chimney walls whose temperatures are below the dew point, but the condensate may evaporate when the walls warm above the dew point. If the chimney wall temperature does not exceed the dew point during the heating cycle of the furnace, the moisture may accumulate in large enough quantities to cause problems such as corrosion of a metal chimney (especially plain steel or galvanized steel), erosion and break up of a tile liner in a masonry chimney and, in severe cases, corrosion of the heat exchanger. Condensate also could enter the home through cracks or joints in the chimney in a worse case situation.

Condensation most likely will not occur at the bottom of the chimney because the stack gas heats the chimney walls as it rises and the bottom will be heated first. This heating of the walls will cause the stack gas temperature to drop, which in turn may reduce the stack gas temperature below dew point, causing condensation to appear on the upper part of the chimney first. This condensation may then run down inside the chimney and drip back as far as the flue pipe and heat exchanger, where corrosion may occur, if not treated.

To prevent condensation, it is necessary that the internal chimney wall temperature always be kept above the dew point. If the chimney is a masonry type, it may have to be fitted with a flue liner, when the temperature loss is too great for the furnace. If the chimney is a metal type, then an "all fuel" chimney must be used, such as a Class "A" triple wall or insulated metal chimney. A liner will act as an insulator and reduce the stack gas temperature loss. Insulation may be added around the liner for further temperature stability. If the chimney is on the home's exterior or passes through a sizable, unheated area of the building, such as a porch, high ceiling attic, etc., and condensing occurs, the chimney must be insulated around its exterior to help the flue hold its temperature. Also, check to see if the chimney is too large for the furnace and other appliances connected to it. If so, reduce to proper size (see Appendix E of NFPA31) by lining. Be sure to use stainless steel liners, such as stainless types 430, 304, or for the toughest corrosion problems, type 316. If the chimney is the correct size for the unit and condensing still occurs, then insulating the vent connector and/or reducing the efficiency of the furnace may have to be done to raise the chimney temperature.

More detailed information may be obtained from the latest edition of the ASHRAE HVAC Systems and Equipment Handbook.

## 2. PROPER CHIMNEY HEIGHT:

The chimney shall terminate at least 3 feet above the highest point where it passes through the roof of a building and at least 2 feet higher than any portion of a building within a horizontal distance of 10 feet. (See Fig. 2a).

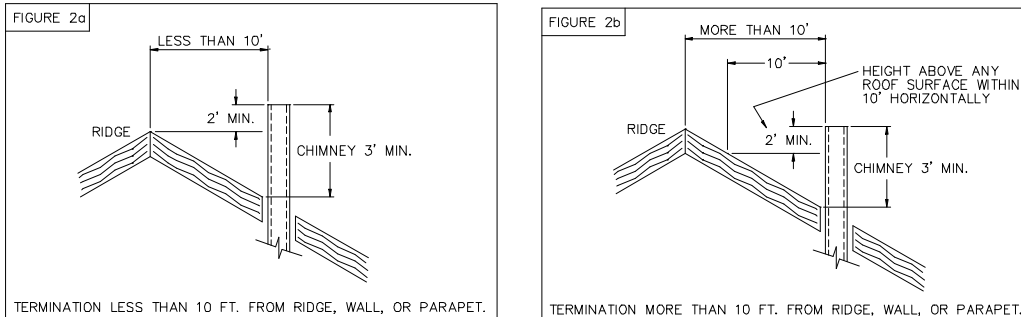

**Fig. 2: Proper chimney termination height for pitched roofs**

If the chimney penetrates a roof more than 10 feet from a ridge, wall or parapet, a minimum of 3 feet above roof or exit point must be maintained. See Figure 2b.

If the roof is flat rather than the normal residential pitched roof, refer to Figure 3 for proper clearances.

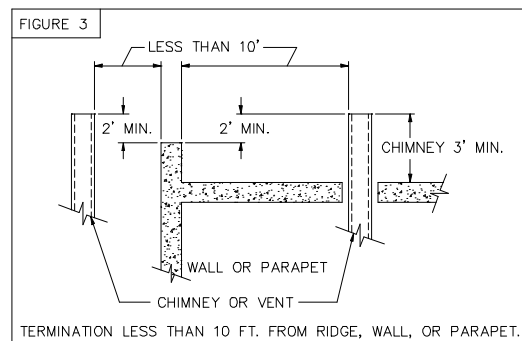

**Fig. 3: Proper chimney termination height for flat roofs**

## 3. PROPER VENT CONNECTOR PIPE/CHIMNEY CONNECTION:

The vent connector pipe should extend only to (and not beyond) the inside wall of the chimney (See Fig. 4). A thimble should be used to connect the vent connector pipe to the chimney so that the vent connector pipe may be readily removed in case of inspection or replacement.

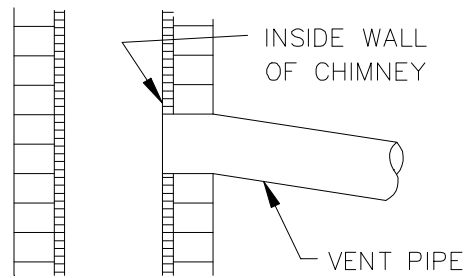

**Fig. 4: Proper insertion of the vent connector in the chimney.**

#### **4. PROPER CHIMNEY BOTTOM LEVEL:**

In cases where the chimney extends to the basement floor, the draft can usually be improved by filling the base of the chimney with sand to within 12 inches of the vent connector pipe after relocating the clean-out door. (See Fig. 5).

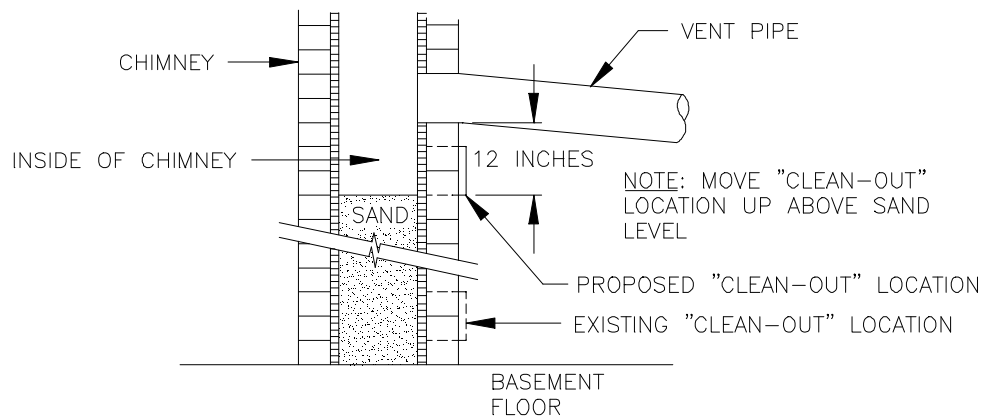

**Fig. 5: Suggested method to improve chimney draft.**

#### **5. TIGHT JOINTS:**

All joints of the chimney must be tightly sealed. The inside of the chimney should be free of any obstructions, such as loose brick, broken pieces of tile, or corroded metal.

#### **6. TIGHT CLEAN-OUT DOORS AND CONNECTIONS:**

All chimney clean-out doors and flue connections must fit tightly so they will seal to avoid air leaks.

#### **7. NO INTERCONNECTED CHIMNEY FLUES:**

If chimney flues are divided or there are multiple flues within one chimney, make sure there are no openings in the partition separating the divided or individual flues.

#### **8. FLUE PIPE CLEARANCES, SIZING AND TYPE:**

The vent connector pipe must not pass through a combustible wall or partition unless adequate protection is provided at the passageway. An acceptable passageway could be either an approved, ventilated metal thimble which is at least 12 inches larger in diameter than the vent connector pipe, or brick work which is at least 8 inches thick constructed into the wall and surrounding the vent connector pipe. (See Fig. 6)

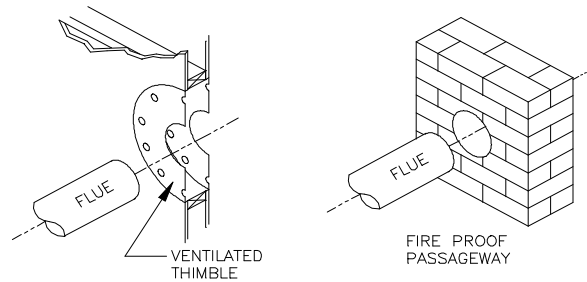

**Fig. 6: Suggested method to accommodate vent connector passage through a wall composed of a combustible material.**

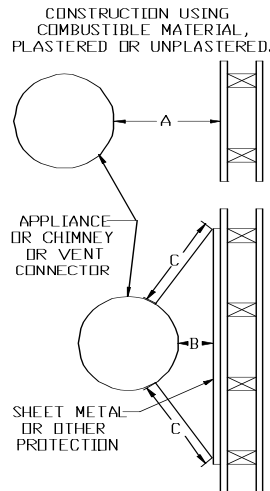

**Fig. 7: Alternate constructions that allow reduced clearances to combustible materials.**

**REDUCTION OF CLEARANCES WITH SPECIFIED FORMS OF PROTECTION:**

Type of protection applied to and covering all surfaces of combustible material within the distance specified as the required clearance with no protection unless otherwise noted, all dimensions in inches, refer to Fig. 7.

Required clearance with no protection from the appliance or chimney connector is:	18 inches		9 inches		6 inches	
	Ceiling	Wall	Ceiling	Wall	Ceiling	Wall
a. 3-1/2" thick masonry wall without ventilation air space....	--	12	--	6	--	5
b. 1/2" insulation board over 1" glass fiber or mineral wool batts...	12	9	6	5	4	3
c. 0.024(24 gauge) sheet metal over 1" glass fiber or mineral wool batts reinforced with wire on rear face with ventilated air space...	9	6	5	3	3	3
d. 3- 1/2" thick masonry wall with ventilation air space..	--	6	--	6	--	6
e. 0.024 (24 gauge) sheet metal with ventilated air space.	9	6	5	3	3	2
f. 1/2" thick insulation board with ventilation air space..	9	6	5	3	3	3
g. 0.024 ( 24 gauge) sheet metal with ventilated air space over 0.024 (24 gauge) sheet metal with ventilated air space....	9	6	5	3	3	3
h. 1" glass fiber or mineral wool batts sandwiched between two sheets 0.024 (24 gauge) sheet metal with ventilated air space	9	6	5	3	3	3

- A. Equal the required clearance with no protection.
- B. Equals the reduced clearance permitted in accordance with the preceding clearance chart.
- C. The protection applied to the construction that covers the combustible material should extend far enough in each direction to make C equal to A.

The vent connector pipe between the furnace and chimney shall be of equal diameter as the flue outlet of the furnace. **The vent connector pipe must be made of 24 gauge (or thicker) corrosion-resistant steel.** The vent connector pipe should be as short as possible and installed so that it has a continuous rise from the furnace to the chimney. The horizontal length of a connector to a natural draft chimney or vent serving a single appliance shall not be more than 75 percent of the height of the vertical portion of the chimney or vent above the connector. Elbows should be minimized and the pipe should be joined with metal screws and supported by straps. All horizontal runs of vent connector pipe should be pitched upward a minimum of ¼ inch per foot of run. A thimble should be used to connect the vent connector pipe to the chimney so the pipe may be readily removed in case of inspection or replacement. See Fig. 6 on preceding page.

**B. VENTING:**

**NOTE:** On the OL6 it is possible to rotate the flue elbow (which is factory installed for vertical discharge) 90° counter clockwise from the vertical position to adapt to various venting systems.

**Notice:** Blocked Vent Switch Installation

The blocked vent switch kit must be installed to comply with CAN STD B140.4 where applicable. For installation instructions see AOPS2687 kit.

**⚠ CAUTION MUST BE TAKEN NOT TO EXCEED 90° ROTATION (OF THE FLUE ELBOW) .**

**ROTATION OF FRONT FLUE ELBOW:**

When an installation requires that the flue exit out the left side casing, remove screw securing the 90 deg. elbow and rotate it 90°. Then, remove knock-out in side casing and extend vent through the opening.

A trim collar may be ordered from Thermo Products to hide the gap around the flue pipe. This trim collar, however, is not required for operation. Trim collar/gasket part numbers(s) 14121 / 330073 for OL6.

The OL6 may be vented through a standard correctly sized chimney.

The OL6 may also be horizontally vented through a sidewall. Thermo Products has available the Field model FDVS-45/FOVP-415 side wall vent kit for such applications. When installing the sidewall vent kit, outside combustion air must also be applied to the burner. The following table identifies application order information.

SIDE WALL VENTING APPLICATION ORDER INFORMATION			
BURNER	FIELD VENT TERMINATION KIT (15' application MAX) THERMO PRODUCTS PART NUMBER (OL6)	SIDE WALL VENT ACCESSORIES KIT (BURNER SPECIFIC) THERMO PRODUCTS PART NUMBER	COMBUSTION AIR INTAKE HOOD KIT (FOR COMBUSTION AIR APPLICATIONS ONLY) THERMO PRODUCTS PART NUMBER
Beckett AFG	AOPS8393	AOPS8394	AOPS8397
Riello BF3	AOPS8393	AOPS8395	AOPS8416
Carlin EZ-1HP	SIDE WALL VENTING NOT AVAILABLE		

**Table 2: Sidewall vent kits**

The Field vent kit is set up with 4 inch diameter vent pipe for OL6 with concentric through-the-wall vent termination/inlet air vent hood. The combustion air inlet pipe diameter is also 4 inch diameter. For Riello, the combustion air inlet pipe will be reduced to 3 inch diameter with the Riello sidewall vent kit. For Beckett, the combustion air inlet pipe will be reduced to 3" diameter with the Beckett sidewall vent kit.



The side wall vent may be installed either through the knock-out on the right or left side casing of the unit or vertically out the top opening of the vestibule.

The combustion air inlet can be installed through either the lower left side casing knockout or the lower right side casing knockout.

### C. DRAFT REGULATORS:

**Note: Do not use with Direct Vent application.**

A draft regulator is supplied with the furnace and should be installed according to the regulator manufacturers recommendations. With the burner operating, use a draft gauge to adjust the regulator to the proper setting. (refer to the instructions enclosed with draft regulator to adjust to the proper setting). When the burner air supply and draft are properly adjusted, the over fire draft should be a negative (-).01" to (-).02" WC, as measured at the 5/16" over fire air tap (See Fig. 12). This tap is provided in the upper burner mounting plate. To measure the flue draft, punch a small hole in the vent connector pipe as close to the furnace as possible and always before the draft regulator.

**Note: Draft over fire may be positive for high fire applications but not to exceed (+).02" WC.**

### D. DUCT WORK/AIR CONDITIONING:

If the furnace is used in connection with summer air conditioning (cooling), the furnace should be installed parallel with or on the upstream side of the evaporator coil to avoid condensation in the furnace heat exchanger. If the cooling unit is installed with a parallel flow arrangement, dampers or other means used to control flow of air should be provided to prevent chilled air from entering the furnace. If such a damper is manually operated, it must be equipped with a means to prevent operation of either unit, unless the damper is in the full heat or cool position.

The duct system should again follow the current design standard of Air Conditioning Contractors of America (ACCA) or ASHRAE Fundamentals volume. The most common location for the A-shaped coil (A style) is shown in Fig. 8.

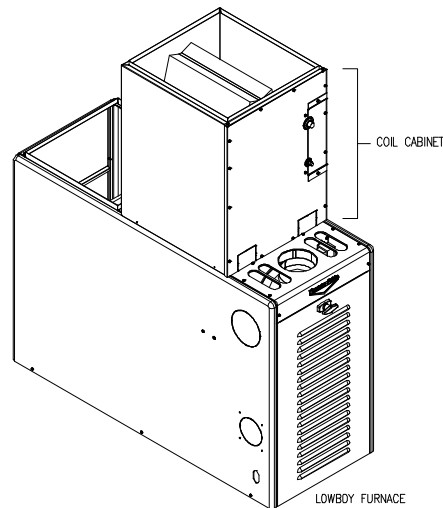

**Fig 8: Acceptable locations for the air conditioner evaporator coil.**

**NOTICE:** The minimum coil pan clearance for a sectional or drum type heat exchanger is three inches unless specified otherwise by the individual coil manufacturer.

**NOTICE:** The minimum return air temperature is 55° F.

## **Airflow Requirements and Sizing of Duct Work:**

The duct system must be sized and installed by a qualified installer or service person, following the design standards of the Air Conditioning Contractors of America (ACCA) or the American Society of Heating, Refrigeration, and Air Conditioning Engineers (ASHRAE). **This furnace has been designed to operate against a maximum external static pressure of 0.5 in. W.G. This is equivalent to 0.1 in. W.G. supply, and 0.1 in. W.G. return, and 0.3 in. W.G. for evaporator coil.**

1. Supply and return air ducts have to be furnished by the installer and run between the appliance, which must be installed outdoors, and the interior of the structure the appliance serves. These ducts must be sealed to the casing of the appliance.
2. To reduce the transmission of vibration and noise to the duct system and to reduce flexure of the duct system due to thermal expansion and contraction, it is recommended that flexible joints be installed at the supply and return duct connections to the unit.
3. The return air duct system must equal the supply air duct system in the flow capacity (CFM) for a given pressure drop. Use a supplier's catalog for proper sizing of outlet and return air registers and grills to ensure that they meet the flow requirements of the run to which they are connected.
4. The duct system shall be sized to provide the maximum airflow rate (CFM) required of the installation. Two common rules for determining minimum airflow in heating and cooling systems follow:
  - a. For heating, 14 CFM of airflow are required per 1000 BTU/hr of heat output, based on steady state operation and a 50° to 80° temperature rise.
  - b. For cooling, 400 CFM of airflow are required per ton of air conditioning. (For reference, a ton of A/C = 12,000 BTU/hr removed from the space.)

Refer to Examples 1 & 2, (page 15) for a sample calculation of how to determine the required minimum airflow rate.

5. Duct sizing is based upon both air velocity and pressure drop considerations. When possible, current practice favors designing ductwork for lower air velocities. (For residences, a maximum air velocity of 800 FPM is suggested.) This results in quieter duct systems, systems which require less fan power (reduced operating costs), and less carefully constructed ductwork (lower initial costs). However, lower air velocities also result in larger duct sizes than necessary at higher velocities. In some cases, space restrictions may limit the ductwork to smaller than optimal sizes.
6. The following method can be used to size ductwork when air velocities are low to moderate.
  - a. Using a floor view of the residence, determine, or layout, the locations of the supply registers and the return air grills. (Generally, supply registers should be located close to sources of heat loss, i.e. windows and doors, around the perimeter of the building. Return grills should be located in central positions as far away from the supply registers as practical.)
  - b. Find a location for the appliance that minimizes the amount of ducting required to connect the appliance to the supply and return air duct systems. Consider issues of access to the oil supply and electrical service, required service and venting clearances, and operating noise when selecting this location.
  - c. Plan an efficient layout for the ductwork connecting each of the supply air registers in the supply system to the unit. Plan and layout ductwork connecting each of the return air grills in the return system to the unit. Measure or estimate the length of duct between each register and grill.
  - d. Select values for the airflow through each register and grill.

- e. Select values for the pressure drops of both the supply and return air systems. Each branch of the supply (or the return) air system will have this pressure drop. The total pressure drop of the supply and return air systems added together cannot exceed the maximum external static pressure that can be supplied by the appliance blower.
- f. Determine the required flow rate for each branch of the supply and return air systems. The total airflow rate, by adding the airflow rate of each branch of the supply system, must equal the minimum required airflow rate (refer to part 3, above). Likewise, the airflow rate of each of the branches of the return air system must sum to the required minimum flow rate.
- g. Using the selected air flow rates for each component of the duct system and manufacturer's literature, or published literature on duct system pressure drops, the pressure drop for each component in the duct system can be estimated.

The ASHRAE Handbook – Fundamentals is an excellent source of duct system design principles and pressure drop data. Conversely, for a specified type of fitting, it is also possible to determine the required size or diameter of the component for a specified pressure drop and flow rate.

- h. The resistance of the take-off and the outlet register (or return grill) should then be summed together to determine the total pressure drop for each branch. This value should be close to the assumed value for the pressure drop of the system. If it is not close, then flow rates for each branch must be adjusted, or the design of the duct system must be altered, to give the proper pressure drops. Usually, the cross-sectional area of the ductwork should be changed in order to adjust the pressure drop to a suitable value. Refer to Example 2, (page 14) for a sample calculation of how to use this method for sizing the supply side ductwork for a residence.

Table 3 shows the air handling capacities of 100-ft. lengths of circular and rectangular ductwork based on a 0.1 in. W.G. static pressure drop. The first column to the right is the airflow rate and the second is the required diameter for a circular duct. The third column is the required cross-sectional area of the duct and the other columns to the left are rectangular ducts with sufficient cross-sectional area to handle the flow at the specified pressure drop. [For lengths of ductwork less than 100 ft., simply multiply 0.1 in. W.G. by the ratio of the actual duct length (in feet) over 100 ft. for the approximate pressure drop.] Use the supplier's catalog for proper sizing of outlet air registers and return air grills to insure that they provide the required flow rate at the desired pressure drop.

CFM	DIA.	SQ."	RECTANGULAR DUCT DIMENSIONS ... INCHES							
45	4	12.5								
65	5	19.6								
100	6	28							6x6	9x4
150	7	38							8x6	12x4
200	8	50							10x6	14x4
250	9	63						8x8	12x6	18x4
300	9	63						10x8	14x6	20x4
400	10	78						12x8	16x6	25x4
500	12	113					10x10	14x8	19x6	30x4
600	12	113					12x10	16x8	22x6	38x4
700	12	113					14x10	18x8	26x6	
800	14	154				12x12	15x10	20x8	28x6	
900	14	154				14x12	17x10	22x8	32x6	
1000	16	201				15x12	18x10	24x8	34x6	
1100	16	201			14x14	16x12	20x10	26x8	40x6	
1200	16	201			15x14	17x12	22x10	28x8	42x6	
1300	16	201			16x14	18x12	22x10	30x8	46x6	
1400	18	255			16x14	19x12	24x10	32x8	48x6	
1500	18	255			17x14	20x12	26x10	34x8	50x6	
1600	18	255		16x16	18x14	22x12	26x10	36x8	54x6	
1700	18	255		17x16	20x14	22x12	28x10	38x8	58x6	
1800	18	255		18x16	20x14	24x12	30x10	40x8	62x6	
1900	20	314		18x16	22x14	26x12	32x10	44x8	64x6	
2000	20	314		20x16	22x14	26x12	34x10	46x8		
2200	20	314	18x18	20x16	24x16	28x12	36x10	48x8		

**Table 3: Suggested Duct Sizes for Homes, Quiet Offices, Or Similar Installations**  
**(Based on a 0.1 in. W.G. static pressure drop per 100 ft. of duct.)**

- The supply and return air ducts, or flexible joints, should be carefully secured and sealed to the appliance housing to prevent air leakage from, or into, the duct system. For best performance, insulate the outside surfaces of the ducts to reduce heat loss from, or heat gain to, the ducts.
- As a final step in the installation, the appliance must be adjusted to deliver a temperature rise within the range of 50° to 80°F. Adjust the blower motor speed to obtain a temperature rise within the acceptable range. The required blower speed will depend on the airflow resistance of a supply and return air duct systems.

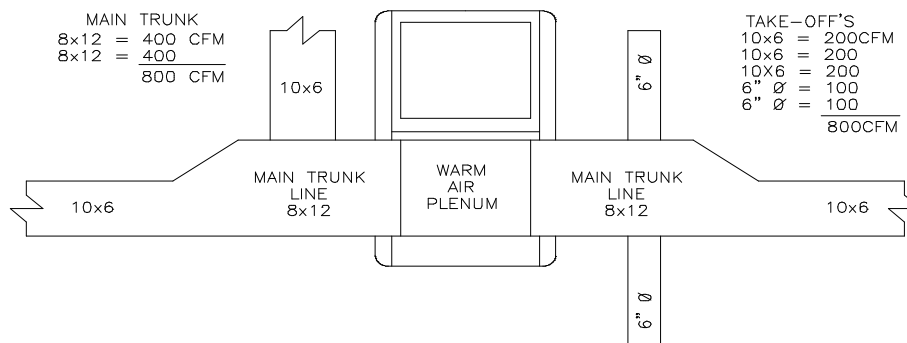

**Fig. 9: Supply air duct sizing Example**

The **RETURN AIR DUCT SYSTEM** should equal the warm air duct system in airflow capabilities.

**NOTE:** When a return register is located in the same room as the furnace, the register must be at least 20 feet away from the furnace.

**SIZING THE DUCT WORK FOR A COMBINATION HEATING AND COOLING SYSTEM:**

Two formulas must be used in determining the CFM requirements of a combustion heating and cooling system.

**1. HEATING CFM:**

HEAT OUTPUT OF FURNACE (BTUH)

$$1.1 \times \text{TR (TEMPERATURE RISE, } ^\circ\text{F)} = \text{HEATING(CFM)}$$

EXAMPLES:

A. 110,000 BTUH OUTPUT

$$1.1 \times 85^\circ\text{F TR} = 1176 \text{ CFM FOR HEATING}$$

B. 110,000 BTUH OUTPUT

$$1.1 \times 70^\circ\text{F TR} = 1429 \text{ CFM FOR HEATING}$$

**2. COOLING CFM: 400 CFM X COOLING TONNAGE (12,000 BTUH PER TON)=AIRFLOW FOR COOLING(CFM)**

EXAMPLES:

$$\text{A. } 400 \text{ CFM} \times 3 \text{ TON } \frac{(12,000 \text{ BTUH})}{1 \text{ TON}} = 1,200 \text{ CFM FOR COOLING}$$

$$\text{B. } 400 \text{ CFM} \times 2.5 \text{ TON } \frac{(12,000 \text{ BTUH})}{1 \text{ TON}} = 1,000 \text{ CFM FOR COOLING}$$

**IMPORTANT: SIZE THE DUCT SYSTEM FOR THE LARGER OF THE TWO AIRFLOW REQUIREMENTS.**

**E. Air Filters Mounted Internal to Furnace:**

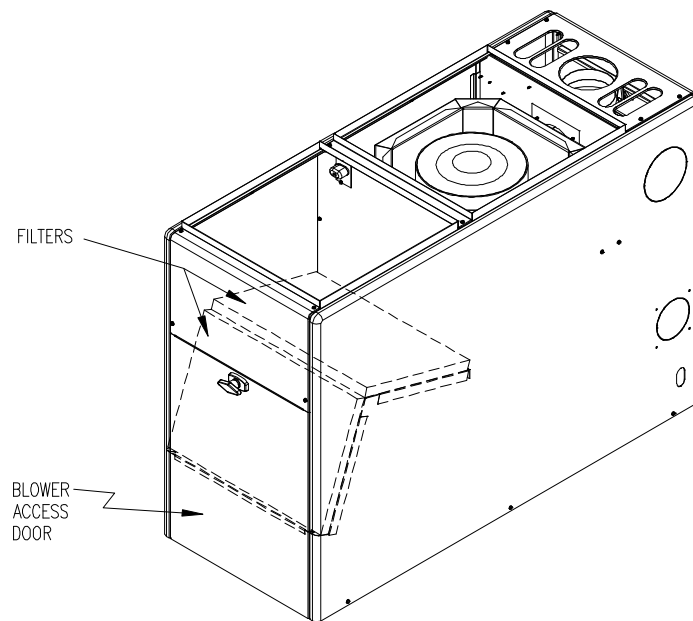

**Fig. 10: Internal filter rack.**

**⚠CAUTION:** Failure to comply with minimum filter installation requirements may affect the performance and/or void the warranty on this unit.

If a method other than internal Thermo Pride filter rack is selected for retention of the filters and/or use of a different filter type is desired, refer to Table 4 below for minimum sizing guidelines for selecting filter for the unit.

Filter Type	Maximum Air Velocity (ft/min)	Model Number	
		OL6	Qty
*Thermo Products Supplied Permanent	600	280 in <sup>2</sup>	2
Standard Permanent	500	576 in <sup>2</sup>	2
Disposable	300	960 in <sup>2</sup>	2

**Table 4: Minimum Required Filter Area (in square inches)**

\* The Thermo Products supplied filter can be cut to size to fit other filter retention systems as long as the maximum air velocity is not exceeded.

**NOTICE:** Any internal stiffeners used in the filter must not be removed, although they can be cut to size as needed.

## F. LIMIT POSITION AND LOCATION

**⚠WARNING:** The predetermined limit locations on all of the Thermo Pride oil fired furnaces have been tested and approved by Thermo Products, LLC. Any attempt to relocate these safety controls or replace these safety controls with a control that is not approved, or is incompatible, may result in personal injury, substantial property damage or death.

The unit must have the limit control installed at the time of unit installation.

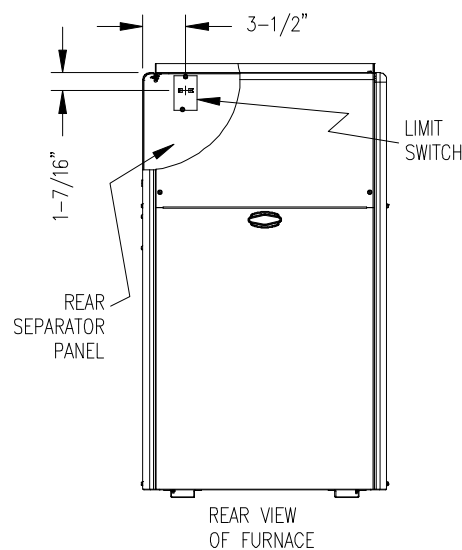
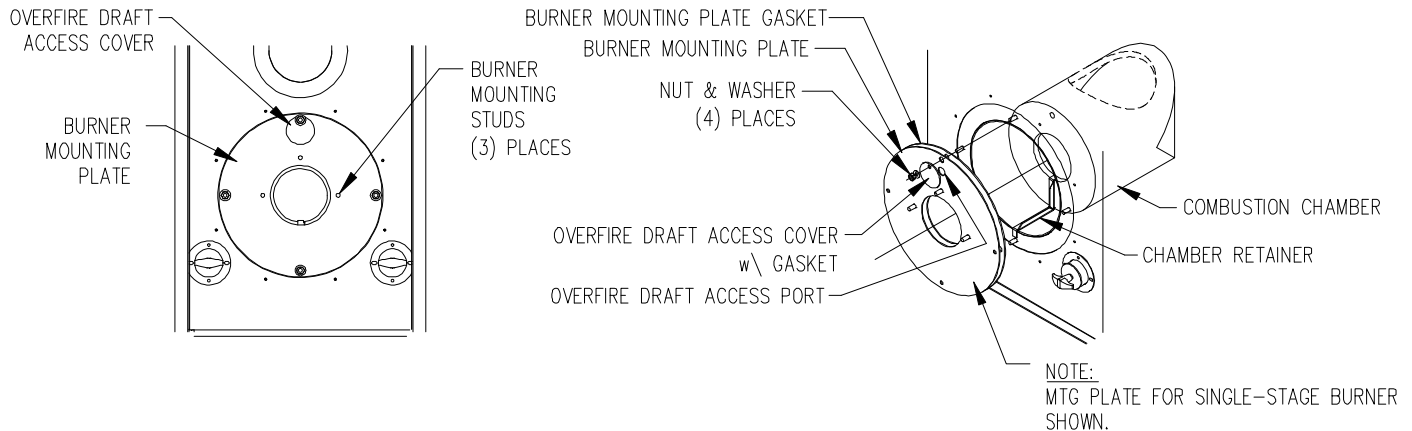

**Fig. 11: Limit location for OL6**

## G. BURNER INSTALLATION:

**NOTICE:** Remove all cardboard packing from around chamber before installing burner.

The oil burner will mount on three stud mounting bolts on the lower mounting plate covering the opening in the front of the heat exchanger. The end of the burner tube should be inserted no further than 1/4 inch back from the inside surface of the combustion chamber. A distance further than 1/4 inch back from the inside chamber wall may cause impingement and sooting. This unit is equipped with a chamber retainer (refer to Fig.12). The retainer secures the chamber during shipping and helps to maintain insertion depth. **DO NOT remove this retainer when installing burner.**



**Fig. 12: Typical location of the over fire air tap and components in burner mounting plate area**

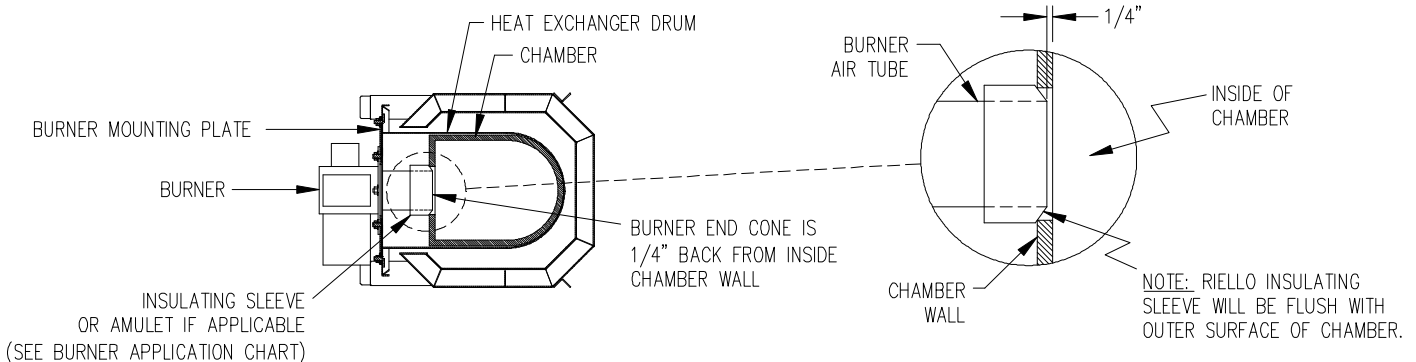

**Fig. 13: Burner insertion illustration (Top view)**

When mounting the burner, the mounting plate (Fig. 12) must be removed to provide access to the area in front of the combustion chamber. A fiber insulating sleeve or amulet is provided on the burner tube of specific Thermo Pride burners.(see Fig. 13). See Thermo Pride burner application chart for type of insulator. Do not allow the burner tube or end cone to physically touch or protrude into the chamber, as excess heat transfer could result in destruction of the tube, end cone or both. The burner tube/end cone is properly positioned, when the end is 1/4 inch back from the inside surface of the combustion chamber wall. **DO NOT CHANGE POSITION OF THE CHAMBER!**

## H. BURNER SPECIFICATIONS AND APPLICATIONS:

### Beckett oil burner application

FURNACE MODEL	THERMO PRIDE'S BURNER SPEC NO.	* INS	BECKETT BURNER MODEL & TUBE LENGTH	HEAD	STATIC PLATE	MAXIMUM NOZZLE SIZE**	SHIPPED NOZZLE SIZE	OIL PUMP PRESSURE (PSIG)
OL6*A072D**B	TP2501	N	AFG-4.5"	F3	3-5/8	0.75X80° S	0.60X80° S	120

### Optional Carlin oil burner application

FURNACE MODEL	THERMO PRIDE'S BURNER SPEC NO.	INS +	CARLIN BURNER MODEL & TUBE LENGTH	HEAD	STATIC PLATE	MAXIMUM NOZZLE SIZE**	SHIPPED NOZZLE SIZE	OIL PUMP PRESSURE (PSIG)
OL6*A072D**C	99032B	N	EZ-1HP 4.5"	N/A	N/A	0.75X60° H	0.60X60° H	120

### Optional Riello oil burner application

FURNACE MODEL	THERMO PRIDE'S BURNER SPEC NO.	INS +	RIELLO BURNER MODEL & TUBE LENGTH	HEAD	STATIC PLATE	MAXIMUM NOZZLE SIZE**	SHIPPED NOZZLE SIZE	OIL PUMP PRESSURE (PSIG)
OL6*A072D**R	C8511325	S	BF3-4.5"	N/A	N/A	0.70X80° H	0.60X80° H	140

Table 6: Beckett, Carlin & Riello burners specifications

**+ INSULATOR S = SLEEVE OR N = NONE**

**THE NOZZLE SIZE GIVES THE NOMINAL FLOWRATE, IN GPH, FOLLOWED BY THE SPRAY ANGLE, IN DEGREE'S, AND THE SPRAY PATTERN, EITHER "H" FOR HOLLOW CONE OR "S" FOR SOLID CONE. FOR EXAMPLE, A NOZZLE RATED AT 0.65 GPH @ 100 PSIG THAT PROVIDES AN 80° SPRAY ANGLE AND A HOLLOW SPRAY PATTERN WOULD BE ABBREVIATED IN THE TABLE AS "0.65 X 80°H".**

For more specific burner information, contact:  
Thermo Products, LLC. P.O. Box 217, North Judson, IN 46366  
Phone 800-476-4328

OIL NOZZLE CAPACITY CHART					
UNITS	NOZZLE SIZE (GPH)			EQUIVALENT HEAT INPUT RATE <sup>NOTE #1</sup> (BTU/HR)	EFFECTIVE HEATING CAPACITY <sup>NOTE #2</sup> (BTU/HR)
	Beckett	Carlin	Riello		
OL6*A060D***	.50	.50	.50	70,000	60,000
OL6*A072D***	.60	.60	.60	85,000	73,000
OL6*A090D***	.75	.75	.70	106,250	90,000

Table 7: Oil nozzle capacity

All rates shown achieved with 120 PSIG pump pressure for Beckett / Carlin, and 140 PSIG pump pressure for Riello.

NOTE #1 Based on #2 domestic heating fuel oil having heating value of 140,000 BTU per gallon.

NOTE# 2 Based on thermal efficiency of 84%-85%.



## I. OIL TANK AND PIPING:

**⚠WARNING:** All local codes and ordinances take precedence with regard to selection and installation of oil storage tank and oil supply (and return) lines. In the absence of local codes, all tanks and lines must be selected and installed according to the instructions in this manual and the Standard for the Installation of Oil-Burning Equipment, NFPA 31-1997, or the latest edition.

1. The use of black steel pipe and malleable iron fittings is recommended for all fuel oil service lines. **Never use galvanized steel piping or fittings for any fuel oil lines.**
2. Where practical, provide rigid supports for the piping.
3. If the piping size in a run must be reduced, use reducing couplings only. Avoid the use of reducing bushings.
4. Remove all pipe thread burrs and inspect the pipe for dirt or other foreign material prior to connecting. If present, remove any deposits in the piping and discard any excessively corroded piping.
5. A readily accessible, design-certified, manual oil shutoff valve, with a non-displaceable rotor member, shall be installed in the fuel oil supply piping within 6 feet of the appliance.
6. A pipe union, or flanged connection, shall be provided downstream from the manual oil shutoff valve to permit removal of the appliance oil pump. Pipe unions must be the ground joint type or flanged-jointed using a gasket resistant to the corrosive action of fuel oils.
7. Pipe dope or thread sealant design-certified to be resistant to the action of fuel oils should be used on all threaded joints. Thread sealant should only be applied to the male member of a joint. The first two threads on the end of the male member of each pipe joint should be clean and free from thread sealant.
8. Connection of the oil supply piping to the appliance should be made from the left-hand side of the burner, facing the burner compartment cover.
9. When tubing is to be used for fuel oil supply lines, use of continuous runs of heavy wall copper tubing is recommended. **Avoid running tubing against any type of heating unit and across ceiling or floor joists.** If possible, install the tubing under the floor.
10. Where tubing is used for fuel oil supply lines, insure the tubing contains no kinks, sharp bends, or collapsed regions where the inside cross-sectional area of the tube is greatly reduced. These will excessively reduce the flow of oil.
11. Flared fittings should be used at all tube joints, when tubing is used for fuel supply lines. **Do not use compression fittings.** Avoid the use of tube fittings in inaccessible locations.

Burners are equipped with a single-stage, fuel pump. This type of fuel pump, when connected with a supply line only, is satisfactory for installations to 6" Hg vacuum, or if the fuel supply is above the burner thus permitting gravity flow of oil to the burner. If the tank is above the burner, and gravity oil feed to the burner is permitted, a single line system may be used. The line should have a gradual slope downward of approximately 1/2 inch per foot, or more, from the tank to a point directly below where it is connected to the pump. Pitching the line upward toward the tank will help prevent the formation of air pockets in the line.

**NOTICE:** An oil safety valve or a delayed-action, solenoid valve should be installed in the oil supply line of all gravity-fed systems.

When the oil tank is located below the level of the burner, it is necessary to “lift” the oil to the burner. A return line should be connected between the fuel pump and tank. This requires insertion of the “by-pass” plug into the fuel pump. If the lift (vertical distance between the supply line inlet and the burner) exceeds approximately 12” Hg vacuum, a two-stage pump should be installed with a return line. When a return line is used with either single or two-stage pumps, in-line air is automatically returned to the tank, making the oil pump and lines self-purging.

Underground tanks should be located outside the building. Installation of above ground tanks is permitted inside buildings, under certain conditions, as well as outside. Consult the Standard for Installation of Oil-Burning Equipment for restrictions. If permitted, connect the burner oil supply line near the base of the tank, opposite of the fill end. Connection at this point tends to flush older oil through and out of the tank. This helps to prevent the accumulation of rainwater and condensed water vapor in the tank, which can cause the tank to corrode.

If the oil supplier does not already use oil additives, it is recommended that additives be used to emulsify any water accumulation in the oil.

#### **J. OIL FILTER:**

It is strongly recommended that an oil filter assembly be installed in the oil supply line to the unit. This filter should have the capacity to trap a 40-50 micron particle.

The filter cartridge should be replaced at least once a year. The filter body should be thoroughly cleaned before installing a new cartridge.

#### **K. ELECTRICAL WIRIING:**

**⚠WARNING:** This appliance must be grounded in accordance with local codes, or in the absence of local codes, with the National Electrical Code, ANSI/NFPA 70-1999, or the latest edition.

All wiring must conform to the provisions of local codes or, in the absence of local codes, with the provisions of the National Electrical Code, ANSI/NFPA 70-1999, or the latest edition, and this instruction manual.

This appliance requires 120 VAC, 60 Hz, single-phase power. Refer to Table 10 for typical electrical current draws of the individual appliance motors, recommended sizes for over-current and short circuit devices, and minimum recommended field wiring sizes. Electrical service must be brought to the unit from a circuit breaker, or fused disconnect switch, in accordance with local codes. The disconnecting switch must be located reasonably close to and within sight of the unit. Care must be taken to ensure correct polarity when wiring the furnace.

Two-wire service, one “hot” lead (L1) and a common (L2), plus a ground conductor, is required. Connect power to the appliance control system at the junction box in the burner compartment. (A knockout fitting is provided on the exterior of the burner compartment for this purpose.) A ground wire must be connected to the grounding wire in the junction box.

Field wiring of power circuits to the appliance should consist of copper conductors rated for at least 15 amp service with an insulation temperature rating of at least 75°C temperature rise. Depending upon code requirements, rigid or flexible conduit is recommended, and may be required. Connect the electric power supply as shown in the wiring diagram located on the inside of the front door.

Typically, control wiring between the appliance and the indoor thermostat, and if used, electronic air cleaner or humidifier, will be required. Field wiring of control circuits should consist of copper conductors rated for at least 15 amp service with an insulation temperature rating conforming to Type T wire, 35°C temperature rise. Depending upon code requirements, rigid or flexible conduit is recommended, and may be required. Make connections between the thermostat, and electronic air cleaner or humidifier (if used), and the fan control module, inside the vestibule. Consult the wiring diagram for the appropriate connection points on the thermostat and the fan control module.

Model	Potential/Frequency/ No. of Phases (V/Hz/Ph)	Supply/Return Air Blower Full Load Current (Amps) @ 115 VAC	Oil Burner Assembly Full Load Current (Amps) @ 115 VAC	Maximum Time Delay Type Fuse or Inverse Time Circuit Breaker Size (Amps)	Minimum Recommended 75 deg. C. Copper Power Wiring Size (AWG)
OL6*A072D48	120/60/1	8.0 PSC	2.6	15	12
OL6**072DV5		10.1 ECM		15	12

Table 10: Typical Electrical Requirements

Wire size selections in Table 10 are based upon Table 310-16 of the National Electrical Code for three copper conductors, with insulation rated for 75 degrees Celsius, contained in raceway at 30 degrees Celsius. For other wire insulation temperature ratings and ambient conditions, refer to the National Electrical Code for the minimum wire sizing requirements.

**NOTICE:** Before the unit is started, the installer and/or electrician must check the following items:

1. Check every electrical connection of “push-on” or “screw-on” type terminals to ensure that all wires and wire connectors are firmly secured. A loose terminal can cause poor flow of electrical power to motors. This may result in very high current draws by these components. If great enough, high current draw will cause blown fuses, burned wires and contactor points, and premature motor failure. Each electrical connection has been factory checked, however, connections may loosen, due to vibration, while the appliance is in transit. **Please be certain that all electrical connections remain tight.**
2. Review wiring diagram for proper routing and connection of all field wiring.
3. All wiring sizes must comply with local codes or the National Electrical Code. To minimize voltage drop to the appliance, the next larger size wire should be used when long wiring runs, in excess of 100 ft., are employed. Refer to the wiring diagrams when wiring or servicing.

In the event a circuit breaker trips or a fuse blows as a result of the operation of this appliance, investigate the appliance electrical system to determine the cause. Correct any electrical faults and abnormal conditions before putting the unit back into operation. **Do not put in a larger fuse and do not exceed maximum fuse size listed on the rating label in order to temporarily “fix” the problem.** The rating label is located on the inside of the burner compartment cover.

### Electronic Air Cleaner (EAC) and Humidifier Installation:

The fan timer on this unit has designated terminals to control the operation of an electronic air cleaner and/or humidifier. These terminals provide line voltage for the control of these accessories, refer to Figure 15 on the next page. Connection between EAC and N6 provides a switched 115 vac to power an electronic fan cleaner. The same-switched 115 vac is available between FAN and N7 and may be used

in conjunction with a humidistat to control a humidifier. These terminals are energized whenever the blower is active.

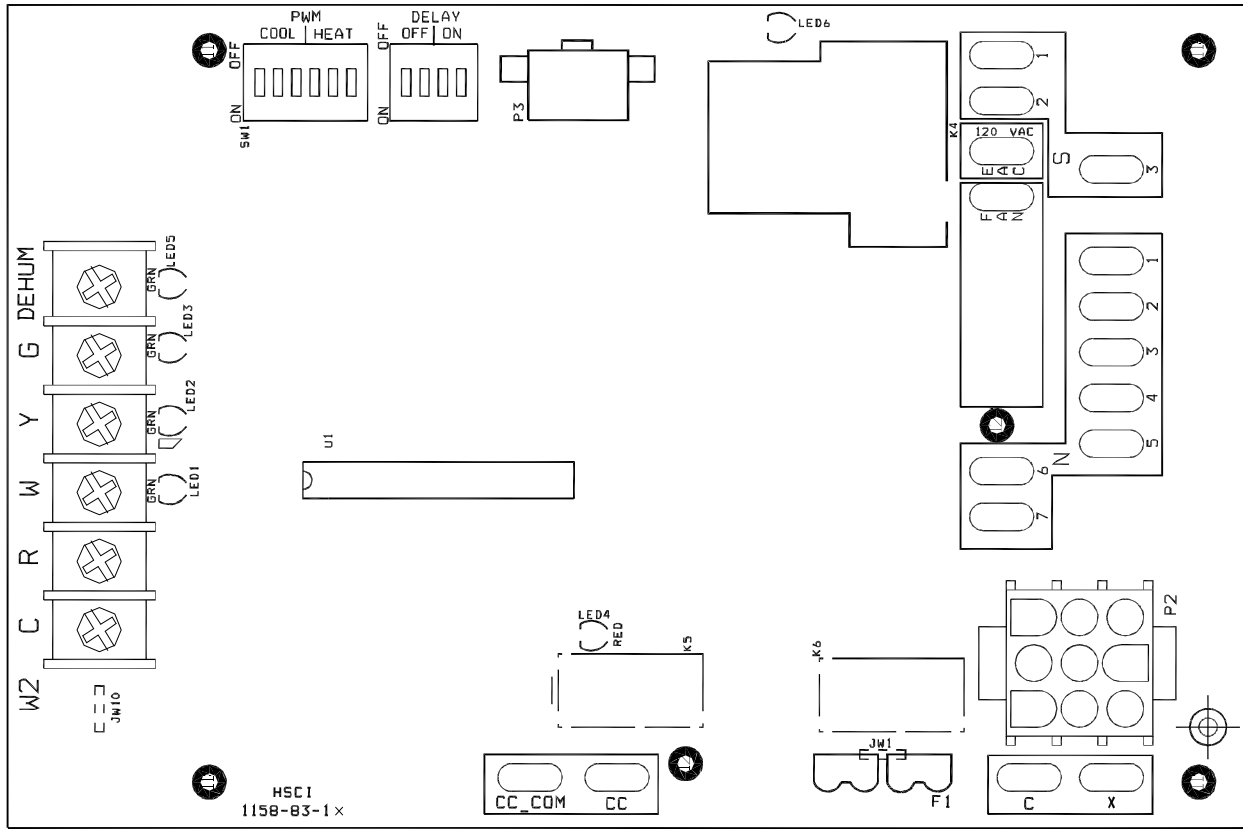

Figure 15: The Fan Control Module

**NOTICE:** It is important to confirm that the operating voltage of the humidifier or EAC being installed matches the output of this control. If not, a field supplied relay or transformer may be necessary to provide the proper control and supply voltage for the accessory being installed. Refer to the manufacturer’s instructions for the humidifier or EAC for additional information.

**Thermostat Anticipator Setting:**

Proper control of the indoor air temperature can only be achieved if the thermostat is calibrated to the heating and/or cooling cycle. Calibration will help to produce a more constant indoor temperature by adjusting the length of the heating/cooling cycle to fit the application. A vital consideration of this calibration is related to the thermostat heat anticipator.

The proper thermostat heat anticipator setting is 0.1 ampere. To increase the length of the cycle, increase the setting of the heat scale; to decrease the length of the cycle, decrease the setting of the heat scale.

Anticipators for the cooling operation are generally pre-set by the thermostat manufacturer and require no adjustment.

Anticipators for the heating operation are of two types, pre-set and adjustable. Those that are pre-set will not have an adjustment scale and are generally marked accordingly. Thermostat models having a scale as shown in Figure 16 on the next page, must be adjusted to each application.

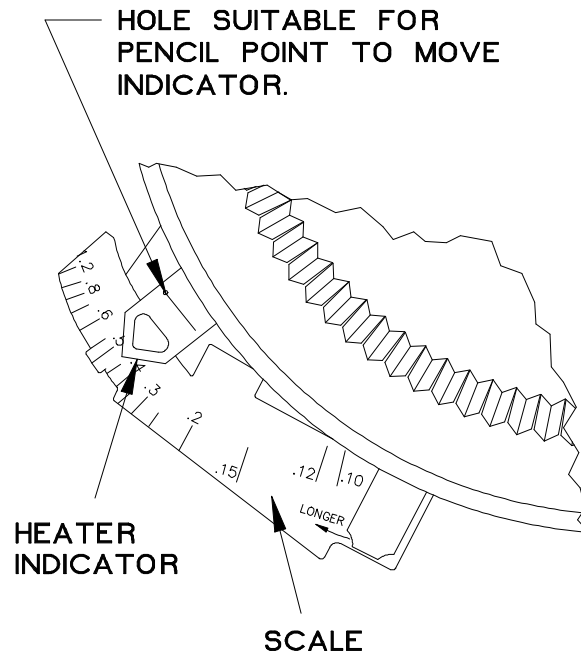

Figure 16: Heat Anticipator Adjustment Scale

In many cases, this setting can be found in the thermostat installation instructions. If this information is not available, or if the correct setting is questioned, the following procedures should be followed:

**Preferred method of adjustment:**

Using an analog ammeter on the lowest scale, such as an Amp Check, connect the meter across terminals “R” and “W” on the sub-base (“RH” & “W” on an isolating thermostat sub-base). If the reading is too low to move the needle on to the measurement scale of the instrument, proceed as follows:

1. Wrap 10 loops of single strand, insulated, thermostat wire around the prongs of an ammeter, refer to Figure 17. Set the scale to the 1 to 5 or 1 to 6 amp. scale.

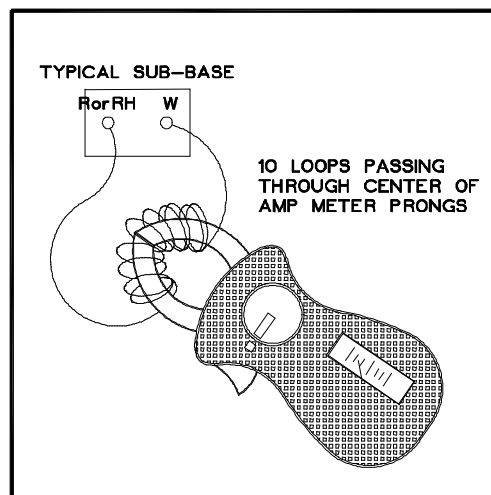

Figure 17: Analog Ammeter w/ Wire Loops to Boost Reading

2. Connect the bare ends of this wire jumper across terminals “R” and “W” on the sub-base (“RH” and “W” on an isolating thermostat sub-base). This test must be performed without the thermostat attached to the sub-base.
3. Let the heating system operate in this position for about one minute. Read the amp meter scale. Regardless of the value of the meter reading, divide the value by 10 (for 10 loops of wire).

This formula can be used to calculate the correct setting for the adjustable heat anticipator:

$$\frac{\text{Ammeter reading}}{\text{No. of wire loops}} = \text{Anticipator Setting.}$$

Or in this case,

$$\frac{2.5 \text{ A.}}{10} = 0.25 \text{ A. (Anticipator Setting)}$$

4. Adjust the position of the anticipator indicator to match the calculated ammeter setting. If a slightly longer cycle is desired, the pointer should be moved to a higher setting. Slightly shorter cycles can be achieved by moving to a lower setting.

5. Remove the meter jumper wire and reconnect the thermostat. Check the thermostat in the heating mode for proper operation.

If a digital ammeter is used, read the current draw directly from meter. (Steps 1 through 3 are not required.) The meter reading is the correct anticipator setting.

## **L. Blower Motor Speed Selection:**

**⚠WARNING:** Turn off the electrical power to the unit, before attempting to change supply air blower speed wiring.

The furnace comes from the factory with the proper cooling speed selected and the heat rise set to approximately 65°F on mid-fire.

The heat rise is determined by the nozzle size and the switch selection on the control board located in the vestibule compartment.

For ECM systems, switches 1, 2 & 3 of switch block SW1 (the six switch red block) are used to select the proper blower speed. Please refer to (figure 15 and table 18).

## Heating Speed Set-ups

OL6\*A072DV5

Furnace Motor Current  
Draw (Amps/ / Watts) vs.  
External Static Pressure (in W.C.)

			Low Fire	Med Fire	High Fire		
		BTUH	60,000	72,000	90,000		
Fan Control SW 1 Switch Settings	Heating CFM	Aprox. Rise (F°)	Aprox. Rise (F°)	Aprox. Rise (F°)	0.2	0.5	
3-OFF 2-OFF 1-OFF	755	73°			1.1/93	1.7/154	
3-OFF 2-OFF 1-ON	826	66°	80°		1.2/105	1.9/168	
3-OFF 2-ON 1-OFF	898	61°	74°		1.8/180	2.3/219	
Factory SW1 Switch Settings	3-OFF 2-ON 1-ON	983	56°	67°	84°	2.0/199	2.7/270
	3-ON 2-OFF 1-OFF	1068		62°	77°	2.2/224	3.0/297
	3-ON 2-OFF 1-ON	1168		57°	71°	2.5/254	3.4/336
	3-ON 2-ON 1-OFF	1282			64°	3.0/298	3.8/380
	3-ON 2-ON 1-ON	1397			60°	3.5/338	4.4/420

 = Recommended Heating Speed Setting

Figure 18-1: ECM blower motor speed chart

**Cooling Speed Set-ups**

**OL6\*\*072DV5**

**Furnace Motor Current  
Draw (Amps / Watts) vs.  
External Static Pressure (in W.C)**

				Air Flow			
	Fan Control SW 1 Switch Setting	Clg. Tonnage	Cool	Continuous	0.2	0.5	
	6-OFF 5-OFF 4-OFF	2	799	500	1.2/100	1.9/162	
	6-OFF 5-OFF 4-ON	2.5	1017	508	1.8/155	2.5/223	
	6-OFF 5-ON 4-OFF	3	1210	605	2.5/223	3.2/298	
	6-OFF 5-ON 4-ON	3.5	1404	702	3.4/310	4.2/394	
Factory SW1 Switch Settings	6-ON 5-OFF 4-OFF	4	1622	799	4.7/444	5.5/535	
	6-ON 5-OFF 4-ON	-	1817	897	6.1/590	7.1/693	
	6-ON 5-ON 4-OFF	5	2010	993	7.9/789	8.8/883	

**NOTE: All information is approximate. Results will vary by installation.**

Figure 18-3: Cooling blower motor speed chart



For PSC systems, the ½ hp motor is equipped with 5 speeds. The unit is set for mid-fire temp rise @ 65°F. See table for proper blower motor set up: **OL6\*A072D48**

ALTERATIONS REQ'D FOR A/C @ DESIGN EXTERNAL STATIC PRESSURE				
COOLING UNIT	HTG Speed by Input			Recommended CLG Speed
	Low fire	Mid Fire	High Fire	
24,000	ML	MED	MH	Med Low
30,000	ML	MED	MH	Med
36,000	ML	MED	MH	Med High
42,000	ML	MED	MH	High
48,000	ML	MED	MH	High

Speed Tap\ Static Pressure	Furnace Airflow (CFM) vs. External Static pressure (in. WC.)				
	0.2	0.3	0.4	0.5	0.6
Low	712	691	682	667	664
ML	902	899	896	883	874
MED	1113	1113	1109	1091	1073
MH	1270	1266	1250	1239	1215
High	1670	1637	1605	1566	1527
Speed Tap\ Static Pressure	Motor Current Draw (Amps/Watts) vs. External Static pressure (in. WC.)				
	0.2	0.3	0.4	0.5	0.6
Low	4.1/408	4.0/398	4.0/395	3.9/385	3.8/378
ML	5.3/540	5.3/535	5.2/527	5.1/512	4.9/500
MED	6.6/665	6.4/644	6.2/634	5.9/609	5.6/584
MH	7.6/772	7.2/739	6.9/713	6.6/682	6.4/663
High	9.6/951	8.4/830	9.0/887	8.8/869	8.4/835

Speed Tap\ Static Pressure	High Fire Temperature Rise vs. External Static pressure (in. WC.)				
	0.2	0.3	0.4	0.5	0.6
Low	119	122	124	127	127
ML	94	94	94	96	97
MED	76	76	76	77	79
MH	66	67	68	68	70
High	51	52	53	54	55

Speed Tap\ Static Pressure	Mid Fire Temperature Rise vs. External Static pressure (in. WC.)				
	0.2	0.3	0.4	0.5	0.6
Low	96	99	100	102	103
ML	75	76	76	77	78
MED	61	61	61	62	63
MH	54	54	54	55	56
High	41	42	42	43	45

Speed Tap\ Static Pressure	Low Fire Temperature Rise vs. External Static pressure (in. WC.)				
	0.2	0.3	0.4	0.5	0.6
Low	79	81	83	84	85
ML	62	63	63	64	64
MED	51	51	51	52	53
MH	44	44	45	45	46
High	34	34	35	36	37

Figure 19A: Heating speed by input

Speed vs. color code for PSC Motor:

- Low = Orange
- Med-Low = Red
- Med= Blue
- Med-High = Yellow
- High = Black

## M. BLOWER CONTROLLER INFORMATION FOR PSC MOTOR

**(Note: for ECM blower controller information see: ECM Operation Manual document # Mo-440)**

### TERMINAL DEFINITIONS & FIELD WIRING

#### Burner Harness Connector P2

- Pin 1- Limit switch connector.
- Pin 2- 120 VAC Line connection.
- Pin 3- Burner pilot contact.
- Pin 4&5- 120 VAC Neutral connections.
- Pin 6- Burner pilot contact.
- Pin 7&8- From oil primary control.
- Pin 9- Limit Switch Input (LSI).

#### Field Wiring to Burner

	Pilot (Tstat)	Neutral	Line
Harness Wires	Yellow Wires	White	Red
Beckett Connections	T-T terminals	White	Black
Riello Connections	T-T terminals	N	L

#### Thermostat / Humidistat connections

- "C" Common / ground
- "W" Thermostat call for heat
- "R" 24 VAC to thermostat
- "G" Thermostat call for fan
- "Y" Thermostat call for cool
- "DEHUM" Humidistat call for dehumidification (TXV systems ONLY)

#### Male quick connect terminals.

- "S1-3" 120 VAC Hot
- "N1-7" 120 VAC Neutral
- "EAC" Electronic Air Cleaner (120 VAC) connection
- "FAN" Fan On Signal
- "X" 24 VAC from transformer
- "C" 24 VAC common from transformer
- "CC" Compressor Contactor
- "CC\_COM" Compressor Contactor Common
- "LOW" Continuous Blower Speed
- "HEAT" Blower heat speed tap
- "COOL" Blower cool speed tap

## **A. Inputs**

### Power supplies

Line voltage is applied between the “S1” and “N1” quick connect terminals. 24 VAC Class II Transformer secondary voltage supplied to X and C

### Limit switch

The 120 VAC optically isolated limit switch input is connected on pin P2-1 & 9. Refer to the Heat Mode section for the control operation.

### Thermostat call for heat “W”

24 VAC thermostat input. A call for heat is recognized when the thermostat connects “W” to “R”. This input has an indicator LED that will light when the control receives a call for heat. Refer to the Heat Mode section for the control operation.

### Thermostat call for cool, “Y”

24 VAC thermostat input. A call for cooling is recognized when the thermostat connects “Y” to “R”. This input has an indicator LED that will light when the control receives a call for cooling. Refer to the Cool Mode section for the control operation.

### Thermostat call for dehumidification “DEHUM”

24 VAC thermostat input. A call for dehumidification is recognized when the humidistat connects “DEHUM” to “R”. This input has an indicator that will light when the control receives a call for dehumidification. Refer to the Cool Mode section for the control operation.

### Thermostat call for fan “G”

24 VAC thermostat input. A call for fan is recognized when the thermostat connects “G” to “R”. This input has an indicator LED in that will light when the control receives a call for fan. Refer to the Fan Mode section for the control operation.

## **B. Outputs**

### PSC Control

The control shall control a five-speed indoor blower motor. Rating shall be 10 FLA, 30 LRA @ 120 VAC. Connections are made via 0.250 x 0.032” male quick connect terminals labeled “HEAT”, “COOL”, and “LOW”. “HEAT” is energized when the heat speed blower is to run. “COOL” is energized when the Cool speed blower is to run. “LOW” is energized during a call for fan is received or a call for dehumidification is received.

### Oil Burner

#### Control

The control provides dedicated contacts to operate the T-T input of an oil primary control. Rating shall be class 2 – 24 VAC pilot duty @ 24 VAC (<200mA).

#### Power

The switched 120 VAC power from the LIMIT switch passes through the board between Pins 1 & 2 of connector P1.

### Compressor contactor

The control provides switched 24VAC to operate a compressor contactor. Rating shall be class 2 – 24 VAC pilot duty @ 24 VAC (<200mA).

### EAC (electronic air cleaner)

The control provides a 120 VAC output for an electronic air cleaner. This output is energized whenever the fan motor is energized (either low, heat or cool speed). Connection is made via male quick connect terminal labeled "EAC".

### Humidifier

The control provides a 120 VAC output for a humidifier. Connections are made to a male quick connect terminal labeled "FAN".

### Status LED

A red LED is provided to indicate any thermostat input has been recognized by the microprocessor on the control. See Diagnostic Features for a function description of operation.

### Thermostat Input LEDs

Four green LEDs are placed beneath their respective thermostat connections (W, Y, G and DEHUM) and operate whenever a call is present. See Diagnostic Features for a function description of operation.

## **C. Operating Modes**

### Standby Mode

All outputs are off and the control is waiting for a thermostat demand. The thermostat inputs, and limit switch are continuously monitored. The control initiates action when a thermostat call is received or limit switch opens.

### Fan Mode

A call for fan ("G") is received from the thermostat. If no other mode is calling for blower operation, the control will operate the fan relay (K4) and power the "Low" blower speed terminal. The fan mode will be operated as long as the "G" input is calling and neither the Heat mode nor the Cool mode is calling for blower operation. When the Heat and Cool modes call for blower operation, their respective outputs will take precedence after their respective turn-on time delays have expired.

### Cooling Mode

A call for cool ("Y") is received from the thermostat. If the heat mode is not active or the anti-short cycle delay is not in effect, the control will energize the "CC" terminal and after a 10 second power demand conservation delay energizes the "COOL" speed blower terminal.

When the call for cool is satisfied, the "CC" terminal is de-energized and the cooling off delay of 45 seconds is started. Forty-five seconds later the "COOL" speed blower terminal is de-energized and the control reverts to Standby Mode.

### Dehumidification Operation

If a call for dehumidification is received while the Cool Mode is active, blower speeds will be reduced. The PSC "COOL" blower speed terminal (1158-100 model only) will be de-energized and "Low" blower speed will be energized.

### Anti-Short Cycle Operation

To prevent compressor short cycling, a call for cooling will be ignored for four minutes after the termination of any cooling call. The anti-short cycle delay is also in effect at power-up.

## Heat Mode

When a call for heat (“W”) is received from the thermostat, if the “Cool” mode is not already active, the “T-T” terminal is energized and the blower on delay is started. The on-off pattern of DIP switch SW2 (positions 1 and 2) select one of four blower on delay values (see Table 11). When the delay time has elapsed, the “HEAT” blower speed is energized. The control remains in steady heat mode until the thermostat is satisfied. When the call for heat signal is removed, the “T-T” terminal is de-energized and the blower off delay is started. The on-off pattern of DIP switch SW2 (positions 3 and 4) select one of four blower off delay values (see Table 11). When the delay time has elapsed, the “HEAT” blower speed terminal is de-energized.

DIP SWITCH 2 SECTION STATE				BLOWER DELAY TIMES		
1	2	3	4	Counter Flow ON - SEC	ON - SEC	OFF - MIN
OFF	OFF			15	30	
ON	OFF			24	60	
OFF	ON			36	120	
ON	ON			48	240	
		OFF	OFF			2
		ON	OFF			4
		OFF	ON			6
		ON	ON			8

**Table 11: ON and OFF Blower Delay Time Switch Settings**

## Motor Blower Speed

Three interconnected blower speed outputs are provided. A “G” call for fan will provide power to the LOW speed tap only. A “W” heat call will provide power to the Heat speed tap only. A “Y” cooling call will provide power to the Cool speed tap only.

In the case of thermostat calls for “Y” and “W” together, blower speed selection will be determined by the input that was first initiated. In the case where the control is in a cooling mode with both “Y” and “W” inputs energized and then the “Y” input is removed, the cooling blower off time will be executed prior to the control switching into a heating mode. In the case where the control is in a heating mode with both “Y” and “W” inputs energized and then the “W” input is removed, the heating blower off time will be executed prior to the control switching into a cooling mode. In the case where a call for fan “G” already exists and either a “W” or a “Y” call is initiated, the blower speed will switch to the respective “W” or a “Y” speed following the blower on delay for that call.

The speed taps are interconnected and interlocked, only one speed may be powered at any one time. When a speed is to be operated, the speed select relays are operated to select the path to the motor tap and then the enable relay is operated to switch the operating power to the selected motor speed tap. If the speed of the running motor is to be changed, first the enable relay removes power from the motor, the new speed is selected and then power is restored to the motor.

## Blower On and Off Delays

Four Heat blower on and four blower off delays are selected by two dip switches for each function. Refer to Table 11 for specific delay values.

## **TROUBLE SHOOTING**

### **DIAGNOSTIC FEATURES**

The control board is equipped with 4 green Input Status LEDs and 1 red Board Status LED. These are intended to provide a quick view into furnace performance without requiring a voltmeter.

The green Input Status LEDs are driven by the “Y”, “W”, “G”, and “DEHUM” inputs and are located directly below those inputs. They will light to indicate the presence of these signals.

The red Board Status LED has two functions:

It will light when the board recognizes a valid input signal and will stay lit until all valid signals are removed. This is intended to show that the board is functioning and able to respond to input signals.

It will flash rapidly while 120VAC is missing from the LIMIT switch. This is intended to give a quick visual indication of the High Limit switch.

### **ECM MODELS**

LED6 measures air flow output of ECM motor. Each blink represents 100 CFM with a short pause between measurement cycles.

## N. STARTUP PROCEDURES:

### A. Heating System

#### 1. Initial Startup:

**⚠WARNING:** Turn off power to furnace. Before the oil piping system is placed into service, it must have been leak tested by a qualified heating contractor.

**⚠WARNING:** For initial start-up of the appliance after installation, it may be necessary to purge the air out of the oil line. A qualified heating contractor should do this.

Review the following items before the initial startup. It may be helpful to review the **Sequence of Operations** in **Section VIII** of this manual, also.

- a. Check all wiring for loose connections and proper hook-up. Refer to the connection diagram.
- b. Leak test all field oil piping connections. Generally, this will involve pressurizing the oil piping with air while being careful to isolate the oil tank at high test pressures. **A qualified heating contractor should perform this service.**
- c. Check to see that the vent terminal is correctly installed and the terminal openings are clear and free from blockage.
- d. Make sure the air filter is in place and relatively clean of dirt and debris.
- e. Make sure the thermostat is set in the heating mode of operation.

#### For Your Safety Read Before Operating:

**⚠WARNING:** If you do not follow these instructions exactly, a fire or explosion may result causing property damage, personal injury or loss of life.

- This appliance does not have a pilot light. It is equipped with an ignition system that automatically lights the burner. Do not attempt to light the burner by hand.
- Do not use this appliance if any part has been under water. Immediately call a qualified service technician to inspect the appliance and to replace any part of the control system and any oil control that has been under water.

#### Operating Instructions:

- i. **STOP! Read the safety information above.**
- ii. Set the thermostat to the lowest setting.
- iii. Turn off all electric power to the appliance.
- iv. This appliance is equipped with an ignition system that automatically lights the burner. Do not try to light the burner by hand.
- v. Rotate the manual oil shutoff valve to the "ON" position.
- vi. Turn on the electric power to the appliance.
- vii. Set the thermostat to the desired setting.
- viii. If the appliance will not operate, call your qualified service technician or oil supplier.

## To Turn Off Oil to Appliance:

- i. Set the thermostat to the lowest setting and set the operating mode switch to "OFF".
- ii. If service is to be performed, turn off the electrical power to the appliance.
- iii. Turn the manual oil shutoff valve to the "OFF" position.

## 2. Adjustment of Burner Combustion:

**⚠WARNING:** Maximum gross stack temperature must not exceed 550°F (288°C) under any circumstances.

**⚠CAUTION:** Do not run the oil pump dry for more than five minutes, as irreparable damage may result.

**NOTICE:** Read the burner operation and service instructions, Model AFG Oil Burner Instruction Manual, before continuing.

To initially adjust and successfully service the oil burner in the appliance heating section, the following test instruments are required:

- A smoke density measuring and rating device,
- A carbon-dioxide (CO<sub>2</sub>) or oxygen (O<sub>2</sub>) analyzer,
- A flue gas temperature measuring device (e.g., thermocouple or thermister probe with readout device),
- An analog or digital multimeter, and
- An oil pressure gauge capable of reading 0-150 PSIG.

## To initially fire the oil burner, proceed in the following manner:

- a. Turn the disconnecting switch, which provides power to the appliance, to the "OFF" position.
- b. Set the room thermostat above room temperature.
- c. Verify the oil tank is filled with sufficient fuel oil to operate the appliance.
- d. Open all valves in the oil supply line to the burner.
- e. Remove the burner compartment cover from the appliance.
- f. Open the inspection cover on the upper mounting plate above the burner.
- g. Turn the disconnecting switch to "ON".
- h. Prime the pump to remove air in the oil supply line.



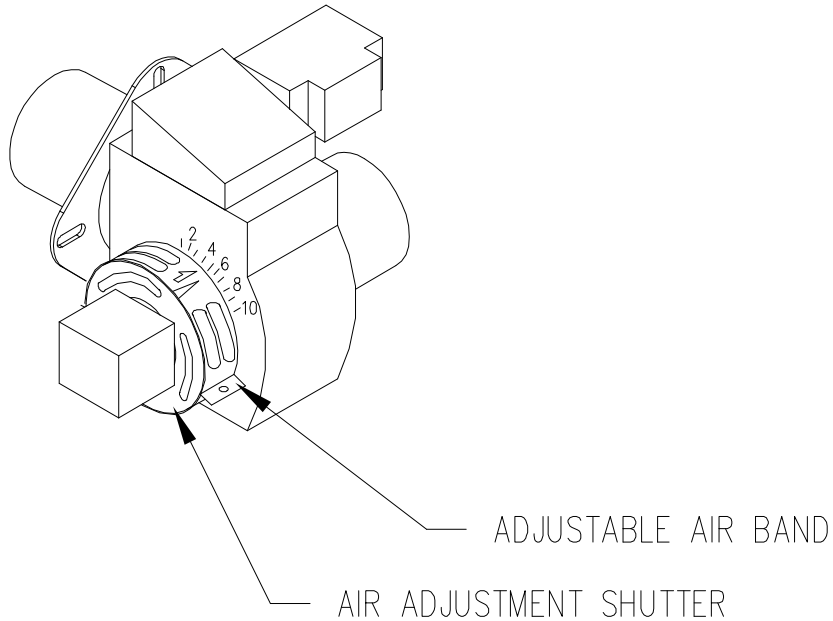

**Figure 19: Preliminary Adjustment of Burner Air Band and Air Shutter**

- i. When ignition is established, make a preliminary burner air adjustment to attain a clean combustion flame. Generally, the burner bulk air band should be about 3/16 inch open and the opening of the burner air shutter set in the range of “2” to “7”, refer to Figure 19.

Replace the inspection cover above the burner.

- j. After the appliance is warmed up to a steady state condition (about 15 minutes), the final burner adjustment should be made using combustion instrumentation for smoke, carbon dioxide (CO<sub>2</sub>) or excess oxygen (O<sub>2</sub>), and flue gas temperature. In order to achieve the most efficient combustion, the following steps must be taken:

- i. **SMOKE:** A smoke sample should be drawn from the heat exchanger flue passageway, which is covered by the vent terminal. (Remove a large machine screw from the front face of the vent terminal for direct access to the flue through the opening.) If the first smoke reading is zero (0), close the air band, or shutter, on the burner until a trace smoke reading is measured.

**NOTICE: To achieve proper combustion and the efficiencies listed in sales brochures, instruments must be used to secure CO<sub>2</sub> or O<sub>2</sub> readings.**

- ii. **CARBON DIOXIDE (CO<sub>2</sub>) OR OXYGEN (O<sub>2</sub>):** Take a CO<sub>2</sub> sample from flue passageway. It is possible to achieve readings of up to 14% CO<sub>2</sub> (or 2% O<sub>2</sub>), but it is better to have a slightly lower CO<sub>2</sub> (or higher O<sub>2</sub>) reading with zero smoke measured. To achieve a lower CO<sub>2</sub> reading, open the air band, or shutter, on the burner until zero smoke is measured.

For example, if a 13% CO<sub>2</sub> (or 3.5% O<sub>2</sub>) is recorded at a trace of smoke, open the air shutter until zero smoke is measured with a 12% CO<sub>2</sub> (or 4.5% O<sub>2</sub>).

Adjustment of the burner to achieve a slightly lower CO<sub>2</sub> reading is recommended, although it slightly reduces combustion efficiency, to keep the heating system within normal operating conditions though external conditions may vary. Some “out-of-spec” conditions which may adversely affect burner performance are, low oil supply temperature, dirty (contaminated) oil, low heating content (BTU/gal) oil, cold heat exchanger surfaces, and downdraft conditions. By adjusting the burner in this manner, an

operational tolerance is established allowing the burner to function well, even under less than ideal conditions. This results in less service and maintenance during a heating season.

- iii. **FLUE GAS TEMPERATURE:** The flue gas temperature will vary to some extent depending on the heat input rate, duct design, and the amount of air flow across the heat exchanger. The suggested minimum **net** flue gas temperature is 350°F, and the maximum **gross** flue gas temperature is 500°F. The lower the flue gas temperature, the higher the heating efficiency. However, stack temperatures under 350°F may result in condensation of water vapor in the flue gases, which in turn promotes corrosion of the heat exchanger.
- iv. **TEMPERATURE RISE:** Temperature rise is equal to the supply air temperature minus return air temperature. Under steady state operating conditions, the temperature rise across the heating section should be approximately 65°F. A higher temperature rise will slightly lower the heating efficiency. A lower temperature rise will slightly raise efficiency, but may cause condensation.

The supply air temperature should be measured in the supply air trunkline approximately 12 inches downstream of the supply air outlet of the appliance.

**NOTICE: Minimum temperature rise is 50°F.; maximum temperature rise is 80°F.**

**Notice: Minimum return air temperature is 55°F**

- k. After final adjustments are completed, tighten all screws to fix the positions of the burner air band.
- l. Check for the presence of oil leaks. Correct any oil leaks found.
- m. Reassemble the burner compartment cover.
- n. Start and stop the unit several times while checking for proper ignition of the burner. The flame should ignite and stabilize without any significant rumbles or pulsations.

### **3. Adjustment Of Heat Input Rate:**

This appliance was shipped from the factory with one, fixed, main burner nozzle sized to produce the low-fire input rate using no. 2 fuel oil at the pump pressure shown on the rating label. The input rate can be changed to the high-fire by switching to the larger burner nozzle and increasing the pump pressure.

The main burner oil nozzles for this unit were selected based upon the following assumed characteristic values of the fuel oil suitable for use with this appliance design:

- For no. 2 distillate fuel (domestic heating) oil having a higher heating value of 140,000 BTU per gallon and a specific gravity of 0.88 @ 60°F. (or “gravity” of 30° API @ 60°F.).

It is possible to make minor adjustments to the heat input rate by adjusting the pump pressure.

Sizeable changes in input rate (especially reductions) should be made by replacing the burner nozzle.

To adjust the pump pressure to the main burner:

- a. With the oil shut off, remove the 1/8 in. NPT threaded pipe plug located on the lower rear side of the oil pump, refer to Figure 22. Attach a pressure gage, capable of measuring pressure in pounds per square inch gage, PSIG, in this opening, on the discharge side, of the oil pump.

**NOTICE: It may be necessary to remove the oil pump to attach the plumbing required to connect a pressure gage to the pump.**

- b. Turn on the fuel oil and cause the appliance to activate the heating section by answering a “call for heat”.

**NOTICE: It may be necessary to bleed air from the oil line before the burner can be fired.**

- c. Allow the heating section to operate for 10 to 15 minutes.

- d. Note the oil pressure at the pump.
- e. To adjust the pressure, use a common screwdriver to turn in the pressure adjustment screw, located on the upper front of the oil pump body.
- f. Allow the fuel flow rate to stabilize for a moment. Recheck the oil pressure.
- g. If required, repeat the oil pressure adjustment again.
- h. When the input rate adjustment has been completed, shut off the fuel oil to the appliance. Remove the pressure gage. Reinstall the pipe plug using a thread compound resistant to the action of LP gases and fuel oil.

To insure the combustion air supply is adequate, it is now necessary to repeat the steps in the previous **Initial Burner Adjustment** section of this manual.

#### **4. Setting Supply Air Temperature Rise:**

**⚠WARNING: To avoid injury from moving parts or electrical shock, shut off the power to the appliance before removing supply air blower compartment door and servicing this appliance.**

All OL6 models are designed and wired at the factory for a blower speed during heating that should result in an approximate temperature rise of 65°F. The temperature rise through the heating section, for any given blower speed, may vary depending on a number of factors. A few of these factors are variations in, the actual resistance of the duct system to airflow at any time, the return air temperatures, and the fuel oil heating value.

Also, fouling of the heat exchanger surfaces will reduce temperature rise. In general, a lower temperature rise through the heating section will result in higher heating efficiency.

**Temperature rise = supply air temperature - return air temperature.**

After 15 to 20 minutes of continuous operation, the temperature rise through the furnace must fall within a range of 50° to 80° F. If the outlet or supply duct temperature is too high, check to make sure the return air filter is clean, the return air registers are free from obstruction, the outlet registers are properly adjusted and clear, and the supply and return air ducts are open. The circulating air blower is not moving enough air if the supply air temperature is still too high. Before proceeding further, turn off the power supply to the appliance and remove the vestibule cover. The speed of the blower must be increased by changing the switch setting on the control board, please refer to Figure 18.

#### **5. Checkout Procedure:**

Before any system of oil piping is finally put into service, it shall be carefully tested to assure that it is "gas-tight", as indicated in the **Heating System Initial Startup** section of this manual.

**NOTICE: All controls on the unit should be checked for proper functioning prior to the qualified service personnel leaving the job site. Specifically the following should be checked:**

- a. With heating system in normal heating operation, check to make certain blower will start and stop automatically under control of the indoor thermostat.
- b. Check safety limit control as follows:
  - i. Shut off incoming power.

- ii. Block return air opening or disconnect blower motor leads.
- iii. Restore power to appliance.
- iv. In the heating mode, set the thermostat above room temperature producing “a call for heat”.
- v. When high air temperatures are reached within the heating section, the high limit control should act to shutdown the burner.
- vi. Shut off the electrical power.

**IMPORTANT: Remove blockage or reconnect blower motor and restore power.**

- c. Make certain the thermostat will automatically start and stop the appliance.

**NOTICE: Heat exchanger oil will burn off on initial firing creating an unpleasant odor. To prevent this odor from occurring more than once, it is suggested the heating section be allowed to run for 30 minutes, or until odor has dissipated.**

### III. USERS INFORMATION SECTION

**A. OIL SUPPLY:** Do not allow the fuel tank to run completely empty. During the summer, keep the tank full to prevent condensation of moisture on the inside surface of the tank. If the fuel tank runs completely dry, it may be necessary to purge the lines of trapped air. Contact a qualified technician to bleed the lines and restart the burner.

**OIL SUPPLY VALVE:** Turn the oil supply valve off if the burner is shut down for an extended period of time.

**B. COMBUSTION AIR SUPPLY:** The burner requires a generous amount of clean combustion air to operate safely. Lack of adequate combustion air can result in erratic operation of the burner, noisy combustion, or fuel odors in the air. NEVER BLOCK THE FURNACE FROM THE SUPPLY OF COMBUSTION AIR. If there is an exhaust fan, dryer or return air grill in the furnace room, there should be increased concern and additional efforts may be required to provide adequate combustion oil to the furnace at all times.

### C. INSPECTION AREAS

**VESTIBULE:** The furnace vestibule area or burner compartment should be inspected by removing the front door of the furnace and looking for signs of excessive heat such as discoloration of components materials damage, from rust or corrosion, soot or carbon build-up.

**EXTERIOR OF FURNACE:** The furnace exterior should be inspected for signs of excessive heat such as discoloration of materials and damage from rust or corrosion.

**FLUE PIPE, VENT PIPE OR CONNECTOR:** The furnace vent pipe should be inspected for signs of rust, corrosion pitting or holes in pipe, and leakage around seams in pipe, indicated by soot or condensate streaks.

**CHIMNEY OR VENTING SYSTEM:** The furnace venting system should be inspected for signs of rust, corrosion pitting or holes, and signs of condensation or moisture leakage from the venting system. If any of the above symptoms are evident, call a qualified heating contractor for assistance.

**⚠ CAUTION: DO NOT ATTEMPT TO MAKE REPAIRS YOURSELF!**

**⚠WARNING: The area around the furnace should be kept free and clear of combustible liquids and material, especially papers and rags.**

**⚠WARNING: NEVER burn garbage or refuse in your furnace. Never try to ignite oil by tossing burning papers or other material into your furnace.**

**⚠WARNING: Thermo Pride oil furnaces are designed to burn No. 1 or No. 2 distillate fuel oil. NEVER USE GASOLINE OR A MIXTURE OF OIL AND GASOLINE.**

**⚠CAUTION: DO NOT ATTEMPT TO START THE BURNER WHEN:**

- 1. Excess oil has accumulated,**
- 2. The furnace is full of vapors**
- 3. The combustion chamber is very hot.**

**IF ONE OR MORE OF THESE CONDITIONS EXIST, CONTACT A QUALIFIED SERVICE PERSON.**

## D. STARTING THE BURNER:

1. Turn the main service switch to "OFF" position.
2. Set thermostat substantially above room temperature.
3. Open shut-off valves in oil supply line to burner.
4. Turn service switch to furnace "ON". If burner starts and runs, but stops again on lockout, it may be necessary to bleed the lines or make burner combustion air adjustments. Contact a qualified service person to adjust and start burner.

## E. FILTER CLEANING AND LOCATION:

**⚠WARNING:** To avoid injury from moving parts, hot surfaces, or electrical shock, shut off the power to the furnace before removing any furnace access doors to service the air filters.

The air filters should be inspected each month and cleaned when dirty. Cleaning the air filters frequently may reduce airborne contaminants from entering the furnace and depositing in the furnace, duct system and home.

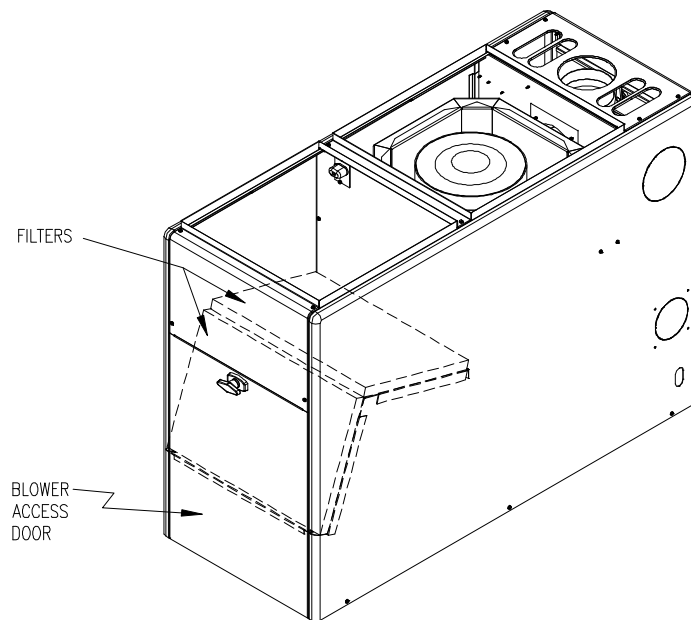

Fig 23: Filter Location for Typical Lowboy Furnace

#### IV. INSTALLER'S INSTRUCTIONS TO USER:

**After completing the installation, the installer shall inform and/or demonstrate to the homeowner the following items:**

1. The location of these instructions. The instructions must be kept along with instructions for any accessories in the plastic pouch with the appliance.
2. The location and use of the manual oil shutoff valve and appliance electrical disconnecting device. The end user must be instructed to always shut off the electric power to the appliance, before shutting off the oil supply.
3. The sequence of operation of the appliance.
4. The correct operation and maintenance of the appliance, as outlined in the **Homeowner/User Information and Routine Maintenance** section of this manual.
5. That failure to maintain and operate this appliance in accordance with these instructions could result in hazardous conditions, property damage, and bodily injury. It may also void the limited warranty on the appliance.
6. Review with and encourage the user to read the label reproductions and all warnings and instructions outlined on the front cover and in Sections I, II, and III, of this manual.
7. Recommend the user have a qualified heating contractor inspect the entire appliance at least once a year. Inform the user of the frequency of inspection required for each item in the **Dealer Maintenance** section of this manual.
8. Inform the user to maintain adequate clearances around air openings into the appliance housing and not to block or restrict the entrance of air into the condenser coil or the burner compartment air openings.

## V. DEALER MAINTENANCE:

### SAFETY DURING SERVICING AND INSPECTION

**⚠WARNING:** Personal injury or property damage could result from repair or service of this appliance by anyone other than a qualified heating contractor. The user may only perform the activities described in the Homeowner/User Routine Maintenance section of this manual.

**⚠WARNING:** To avoid injury from moving parts, or electrical shock, shut off the power to the appliance before removing blower compartment door and servicing this appliance.

**⚠CAUTION:** When servicing controls, label all wires prior to disconnecting. Reconnect any removed wires correctly. Wiring errors can cause improper and dangerous operation. Dangerous operation can result in injury or damage.

**IMPORTANT:** Verify the proper operation of this appliance after any servicing is performed.

A qualified heating contractor should perform the following maintenance procedures at the beginning of each heating season. Correct any deficiencies at once.

### A. GENERAL INSPECTION:

**⚠WARNING:** Shut off oil and disconnect power before continuing with this inspection.

1. Vent terminal - Visually inspect the terminal for restrictions, loose or missing fasteners, external damage, and carbon build-up. Clean the vent terminal and the screen(s) covering any opening in the terminal. Repair any minor damage. If necessary, replace a severely damaged or degraded vent terminal.
2. Burner – Visually check the burner, and below the burner, for indications of oil leaks. Correct any, if found. Remove the burner and measure the ignition electrode gap. It should be set to 5/32 inch. Adjust it, if necessary. Clean any accumulation of dust, dirt, or debris from the air shutter or air band openings. If necessary, clean housing and blower wheel with a damp cloth. Use a vacuum to remove any lint or dust from motor assembly. Add a few drops of non-detergent oil to each of the motor lubrication holes.
3. Combustion Chamber - Inspect the liner for deterioration, oil and carbon build-up. If the accumulation of oil or carbon is significant, this is a strong indicator that the burner is out of adjustment. Inspect the burner nozzle for partial blockage and excessive wear. Replace it, if required. Check and adjust oil pump pressure, if needed. Refer to **Initial Heating System Adjustments** section of this manual.

**Note:** Care must be given to ensure no damage occurs to the chamber insert. (Refer to Figure 12)

4. Heat Exchanger – Visually inspect the heat exchanger for excessive carbon (soot) build-up. Refer to the **Heat Exchanger** section of the manual.
5. Oil Filter – Replace the supply line oil filter cartridge with a new filter of the same type and rating. Clean the body of, or mounting plate for, the oil filter.
6. Labels and Markings - Clean all appliance labels, markings, and instruction plates, as necessary, and verify that all are still legible. Any illegible or missing markings must be replaced. Replacements can be obtained by contacting Thermo Products.



## B. HEAT EXCHANGER:

**⚠WARNING: A qualified heating contractor must clean the heat exchanger.**

At least once a year, inspect the heat exchanger for evidence of corrosion, pitting, warpage, deterioration, and carbon (soot) build-up. A layer of soot on the inside of the heat exchanger will act as an insulator and reduce heat transfer, resulting in less heating efficiency.

Also, look for loose or deteriorated gaskets and insulation around the flue pipe, the burner, and accessible areas of the heat exchanger. If this inspection indicates heat exchanger cleaning is necessary, follow the heat exchanger cleaning instructions below.

## C. HEAT EXCHANGER CLEANING INSTRUCTIONS:

**⚠WARNING: THE HEAT EXCHANGER MUST BE CLEANED BY A QUALIFIED SERVICE PERSON.**

It is important to inspect and clean the heat exchanger once a year, or as necessary, to remove any build-up of soot. A layer of soot on the inside of the heat exchanger will act as an insulator and reduce heat transfer, resulting in less efficiency.

1. To clean the heat exchanger, first turn off all power to the unit. Remove clean-out plugs, the vent connector pipe to the chimney, the burner, and the burner mounting plates. When removing the clean-out plugs, turn T-handle counterclockwise approximately two (2) full turns or just until the plug is able to be pulled from tube. Take care not to remove T-handle from assembly.
2. With access to the inside of the heat exchanger through the burner area, clean-out openings, and vent pipe connection, it is possible to use a long, flexible wire brush and an industrial type vacuum cleaner to remove any soot build-up. **NOTE:** A one inch (outside diameter) vacuum cleaner hose will fit into the radiator.

To vacuum and brush the outer radiator of the heat exchanger, go through the clean-out openings in both directions, as shown in figure 25 on the next page.

3. Reassemble the furnace to its original construction\*. Remount the burner being certain that the air tube is properly inserted into the chamber opening. If heavy soot deposits were found in the heat exchanger, this may indicate the burner is out of adjustment.

\*When returning clean-out plugs to their original position, insert plug and turn T-handle clockwise 2-3 turns or until plug cannot be pulled from the clean-out access tube. This is sufficient for sealing the access tube.

**Replace any damaged or corroded components. All gaskets and insulation must be inspected, and replaced, if they show any signs of damage.**

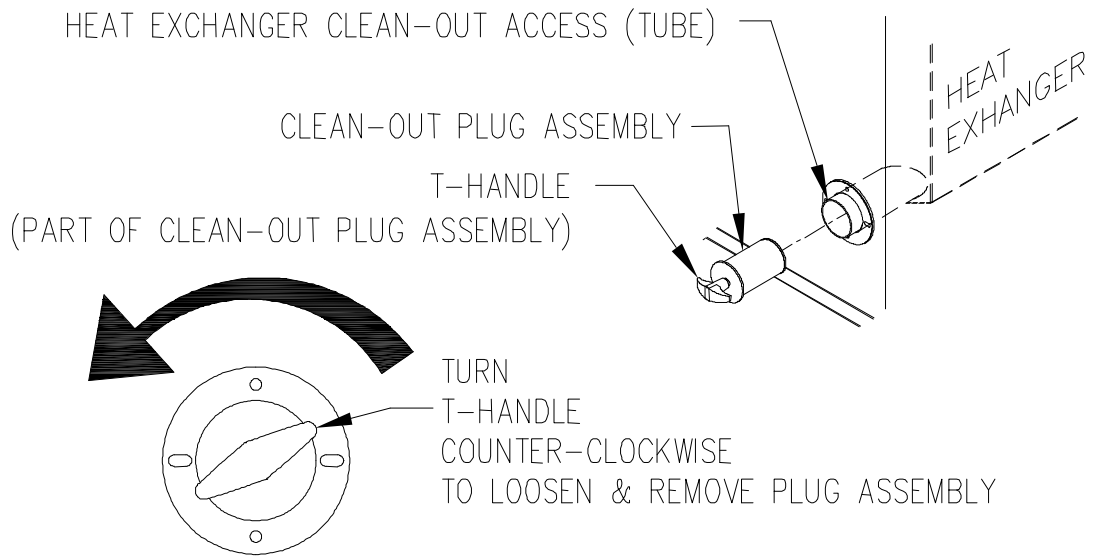

**Figure 24: Heat Exchanger Clean-Outs**

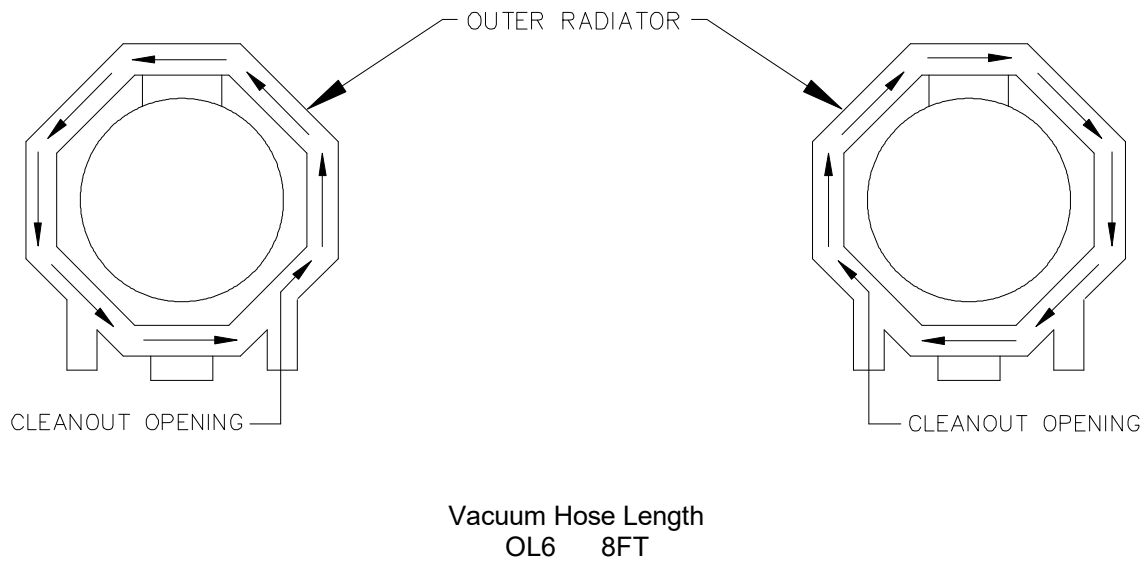

**Fig. 25: Recommended method and device for cleaning inside of heat exchanger.**

4. Operational Check:

**⚠CAUTION: Before troubleshooting, familiarize yourself with the start up and check out procedures**

**NOTICE: After reassembling the appliance, check for fuel oil leakage from the supply piping.**

- a. Check proper operation of the ignition system and for proper combustion.
- b. Observe the main burner flame. If the flame appears strange or abnormal in character, look for a component or components that were not reassembled correctly. If the components have been reassembled correctly, check for a blocked vent, malfunctioning combustion air blower or fuel pump, and partially blocked burner nozzle.

**D. ELECTRICAL SYSTEM:**

**⚠WARNING: When servicing controls, label all wires prior to disconnecting. Correctly reconnect any wires removed during servicing. Wiring errors can cause improper and dangerous operation. Dangerous operation can result in injury or damage.**

1. Check all wiring for loose connections and any signs of damage, or unusual wear. Replace any damaged or frayed wiring and tighten any loose connections.
2. Use a voltmeter, or a multimeter, to check for adequate voltage at the field connections when the appliance operating.
3. Use an ammeter, or a multimeter, to check the current draws of the blower motor and burner assembly, to assure they are not exceeding rating label current specifications for each component. Also, refer to Table 10 in the electrical wiring section of this manual for electrical specifications on these components.
4. Check for correct operation and proper settings (if manually adjustable) of all controls.

**E. SUPPLY/RETURN AIR BLOWER:**

Check in the blower compartment for dust, dirt, debris, and for the presence of insects. Remove any foreign material. Clean the blower wheel, housing, and compartment of dust and lint with a vacuum.

The blower motor has sealed bearings that are permanently lubricated. **The blower motor bearings do not require oil or any type of additional lubrication.**

**F. SUPPLY/RETURN AIR FILTER:**

The filter rack is located in the blower compartment of the furnace. The filters should be inspected regularly. When the filters are dirty, they should be cleaned or replaced to assure proper heating/cooling system operation. Follow the cleaning, removal and replacement procedure below.

**Filter maintenance procedure:**

Shut off the electrical power to the unit. Open the blower access door. Slide the air filters out of the filter rack. Clean the filters by either vacuuming, rinsing with tap water, hosing, or dipping in an ordinary detergent solution. After cleaning and drying the filters, replace the completely dry filters in the rack. If the filter has a supporting mesh, the mesh side of the filter must be placed towards the furnace.

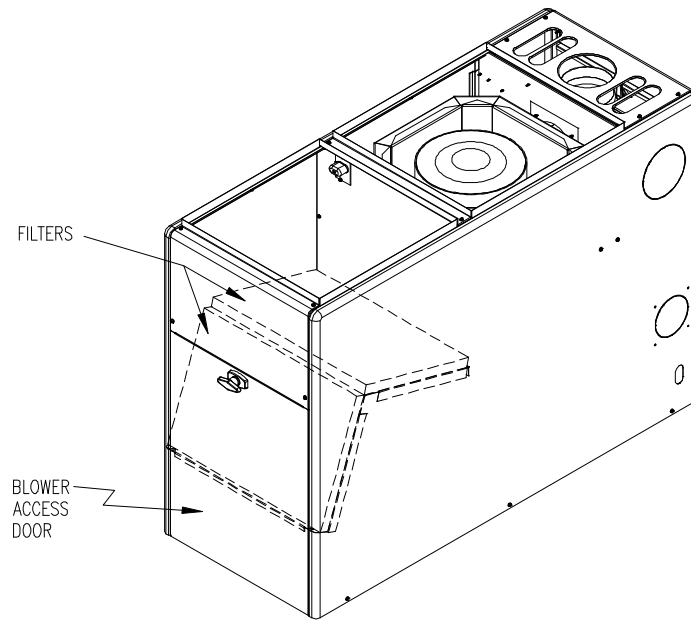

Figure 26: Location of Supply/Return Air Filters

### Filter replacement:

To ensure an adequate replacement filter is selected, should the filter require replacing, refer to Table 4, in **Air Filters** section of this manual, for the minimum filter areas required for different types of available filters.

**NOTICE: Remind the homeowner of the importance of monthly filter inspections during operation to ensure maximum operating efficiency.**

### G. EXTENDED APPLIANCE SHUTDOWN:

**⚠CAUTION: Do not attempt to start burner when:**

- Primary reset has been engaged more than two times.
- Excess oil has accumulated in the combustion chamber or beneath the burner assembly.
- The combustion chamber or the heat exchanger is full of fuel vapor.
- The combustion chamber is very hot.

Should the appliance be shutdown or turned off for an extended period of time, several steps can be taken to help insure a smooth and reliable restart of the heating system.

#### ON SHUTDOWN:

1. Close oil supply (or manual shutoff) valve.
2. Disconnect all electrical power to the unit.

3. Fill the oil tank to reduce water condensation in the tank.
4. If the shutdown period will exceed one heating season, an oil stabilizer should be added to the oil tank. Consult your oil supplier for recommendations.

**ON STARTUP:**

1. Have system inspected and started by a qualified heating contractor.
2. Check oil level in tank. If the tank has not been filled with fresh oil, inspect the remaining oil for signs of contamination with water, algae, dirt or other impurities. If excessive, consult your oil supplier for recommendations.
3. Change the oil filter cartridge and clean the canister.
4. Set the room thermostat above room temperature.
5. Open all valves in the oil supply line.
6. Open the inspection cover on the upper mounting plate.
7. Turn on the electrical power to start the burner. If the burner does not start, immediately reset the manual overload switch on the motor (if so equipped) and the safety switch of the burner primary control. Bleed air from the fuel oil line as soon as the burner motor starts rotating. To bleed the fuel pump, attach a clear plastic hose over the vent plug, refer to Figure 27. Loosen the plug and catch the expelled oil in an empty container. Tighten the plug when all the trapped air appears to be purged. If the burner stops during bleeding, wait three to five minutes for the control safety switch to cool. Then manually reset the switch. Continue bleeding the line until the air is completely removed.

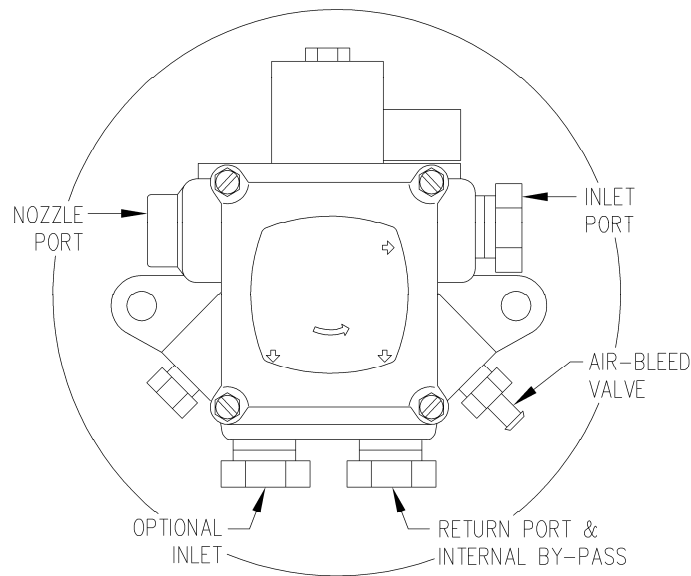

**Figure 27: Location of Oil Pump Vent Plug**

8. Follow the previous **Initial Burner Operation** procedures.

## VI. HOMEOWNER/USER INFORMATION AND ROUTINE MAINTENANCE:

**⚠WARNING:** Never burn garbage or refuse in this appliance. Never try to ignite oil by tossing burning papers or other material into the combustion chamber.

**⚠WARNING:** Oil-fired appliances produced by Thermo Products are designed for burning No. 2 distillate (domestic heating) fuel oil. Never use gasoline or a mixture of oil and gasoline.

**⚠CAUTION:** Do not use this appliance if any part has been under water. Immediately call a qualified service technician to inspect the furnace and to replace any part of the control system and any oil control that has been under water.

**⚠CAUTION:** Should overheating occur, or the oil supply fail to shut off, shut off the electrical power to the appliance, before shutting off the manual oil valve.

**⚠CAUTION:** The area around the appliance, including the top of the unit, must be kept clear and free of combustible materials, gasoline, and other flammable vapors and liquids.

**⚠CAUTION:** The appliance vent terminal may be hot. If the terminal is hot, allow it to cool before touching it.

**⚠CAUTION:** Do not attempt to make repairs yourself. Contact your local qualified heating contractor.

Under normal conditions, this appliance will operate in either heating or cooling mode, depending upon the mode of operation set at the thermostat. The unit will cycle on and off automatically, as required, to maintain the air temperature within the residence as closely as possible to the thermostat setting. However, in rare cases, the unit may shutdown automatically during a normal cycle or may not operate under seemingly normal conditions.

**If the unit will not operate in the heating mode**, it may be possible to reactivate the unit by resetting one of the burner controls. To attempt resetting of the burner controls, follow this procedure.

1. Turn the thermostat temperature setting down and set the operating mode to "OFF" or "COOLING".
2. Remove the furnace front door.
3. Check to see if the LED on the burner primary (ignition) control module is flashing at a rapid rate. If so, the control may have "locked out". To recycle the control system, depress the reset button. Refer to Figure 28.
4. Replace and secure the furnace front door.
5. Set the operating mode on the thermostat to "HEATING" and turn the thermostat temperature setting up.

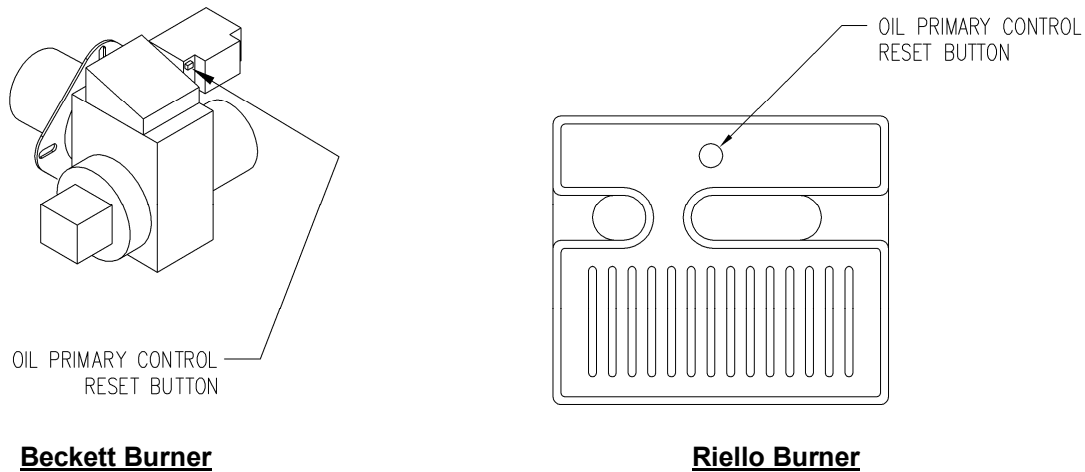

**Figure 28: Location of oil primary control reset button**

If this action does not reactivate the unit, contact a qualified service agency for assistance.

In general, if the thermostat is set in the heating mode, the heating system functions entirely automatically. However, under certain circumstances, the appliance may not be able to fire the burner. For instance, if the manual oil shutoff valve has been closed or the oil tank is out of fuel, the oil line may have air trapped in it. It will be necessary to purge the air by bleeding the supply line from the tank to the burner again for the heating system to operate. Refer to the instructions under the **Extended Appliance Shutdown** section of this manual.

**NOTICE: Thermo Products recommends that the user/homeowner, contact a qualified service agency for assistance in bleeding the fuel line(s) and lighting off the heating section.**

The following maintenance points should be reviewed periodically to assure the heating and cooling systems continue to function properly.

**⚠WARNING:** Shut off unit and disconnect the power source before disassembling the unit.

**⚠WARNING:** Never operate the appliance without clean air filters in place.

**⚠CAUTION: This appliance requires air for combustion, ventilation, and cooling. Do not block or obstruct air openings in the unit and the air space around the perimeter of the unit.**

1. At least every three months, under normal usage conditions, check and clean all air filters in the appliance and, if present, in the duct system. If excessively dirty air filters are not cleaned, or changed, poor system performance will result due to reduced airflow. Low airflow places unnecessary strain on the compressor, possibly causing the system to shutdown on the refrigerant high-pressure switch. Refer to Figure 23 for a sketch of the filter location.
2. Do not allow the fuel oil tank to run completely empty. During the summer, keep the tank full to reduce condensation of moisture on the inside surface of the tank. If the fuel tank runs completely dry, it may be necessary to bleed air from the fuel lines. **Contact a qualified heating contractor to bleed the lines and restart the burner.**
3. Check the supply and return air connections to the appliance to insure the seals between the duct and appliance and the appliance and home are intact. Check the ducts for any signs of collapse, holes, or excessive corrosion. Repair or replace components as required.

## VII. TROUBLESHOOTING:

### **THIS SECTION IS ONLY TO BE PERFORMED BY TRAINED, QUALIFIED SERVICE PERSONNEL, AND NOT BY THE FURNACE OWNER.**

#### **NOTICE: Before troubleshooting, familiarize yourself with the Initial Startup, Checkout Procedure, and Troubleshooting Flowchart.**

Refer to the appendices of this manual for an electrical schematic, a connection diagram, flowcharts to assist in troubleshooting, product specifications, and a replacement parts list follow for this appliance.

1. Check for 115VAC line supply voltage to the furnace. If there is no supply voltage, check fuses and service switch.

**⚠CAUTION:** When testing electrical equipment, always follow standard electrical procedures.

2. Make sure thermostat is calling for burner operation.
3. Check oil supply and make sure all valves are open.

#### **A. DIAGNOSTICS:**

To assist in troubleshooting this appliance, it is equipped with an integrated safety and ignition control with diagnostics. Refer to control manual provided with burner for operation and fault codes.

If it is necessary to troubleshoot the flame sensor independently of the burner primary, the following procedure may be used.

#### **B. CAD CELL CHECKOUT PROCEDURE:**

1. Stop burner and shutoff electrical power to the appliance.
2. Open burner junction box (on top of the burner blower) and remove the plug-in portion of the cad cell by pulling it forward from and clear of the receptacle. Connect an ohmmeter across cad cell pins. With the cell exposed to direct room light, the measured resistance should be less than 2500 ohms (in fact, it may be less than 200 ohms).
3. Check the resistance across the cad cell pins with the cell covered (protected from exposure to ambient light). The resistance should be greater than 20,000 ohms.
4. If cell resistances are different from above, replace cad cell, (TP part # 350104).
5. Carefully reinsert the plug-in portion of the cad cell into the receptacle. If the cad cell appears to be functioning correctly, troubleshoot the fan control module and the safety and ignition control (primary control) module, according to the instructions covering the devices.

The troubleshooting chart beginning on the following page should help identify the type of malfunction or deviation from normal operation. To use this diagram, just follow the instructions in the boxes. If the answer is yes or the condition is true, go down to the next box. If the answer is no or the condition is false, go to the box on the right. Continue checking and answering questions and conditions in each box until a problem and/or repair is found. After any maintenance or repair, the trouble shooting sequence should be repeated until normal system operation is achieved.



## VIII. Sequence of Operations Flow Chart:

### Mode of Operation

Standby  
(At any time the oil valve is not energized)

### Control System Action

Continous safe operation check. If flame simulation condition present, system shuts off oil valve,ignitor, and burner motor; activates fast flashing LED.

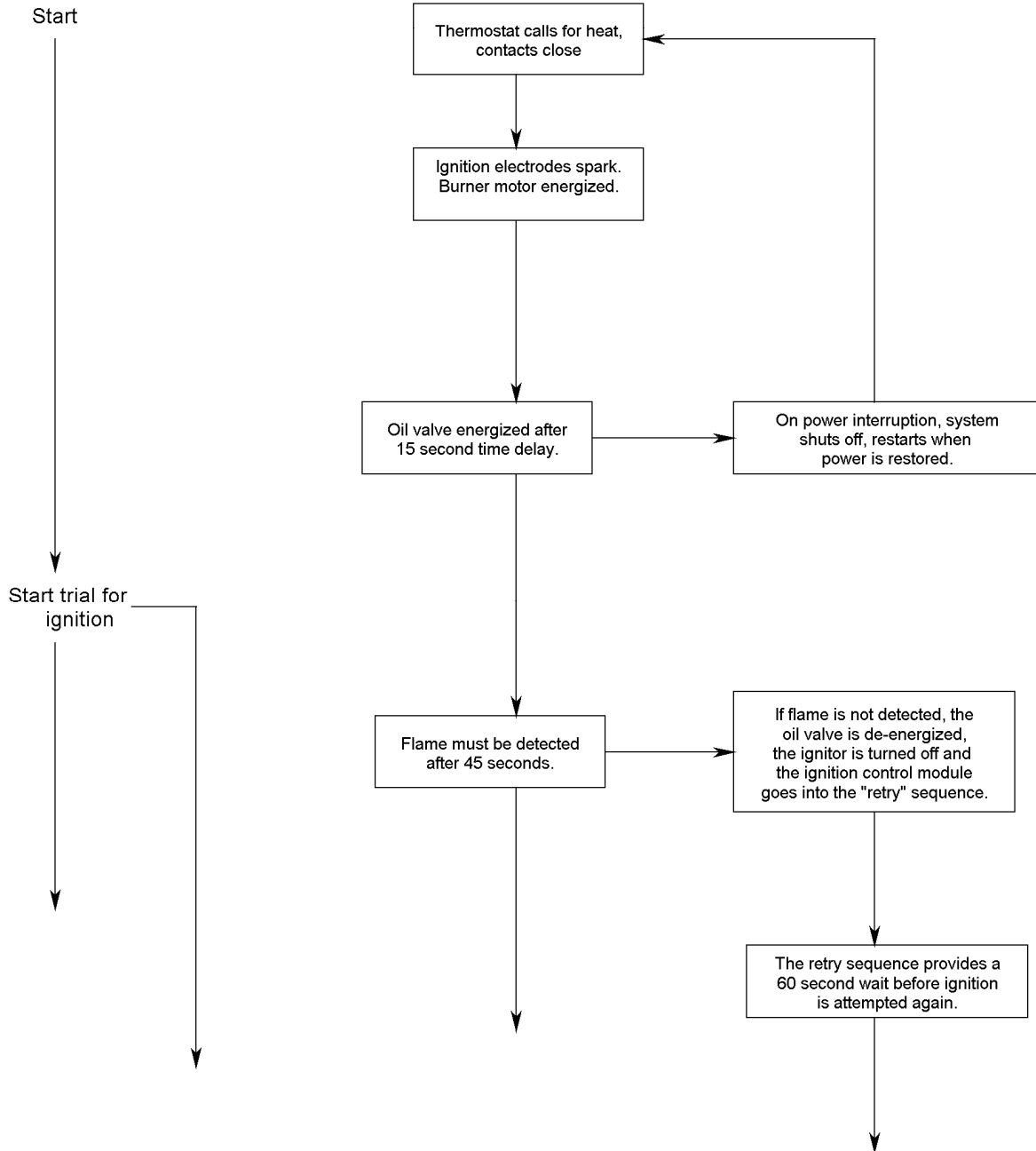

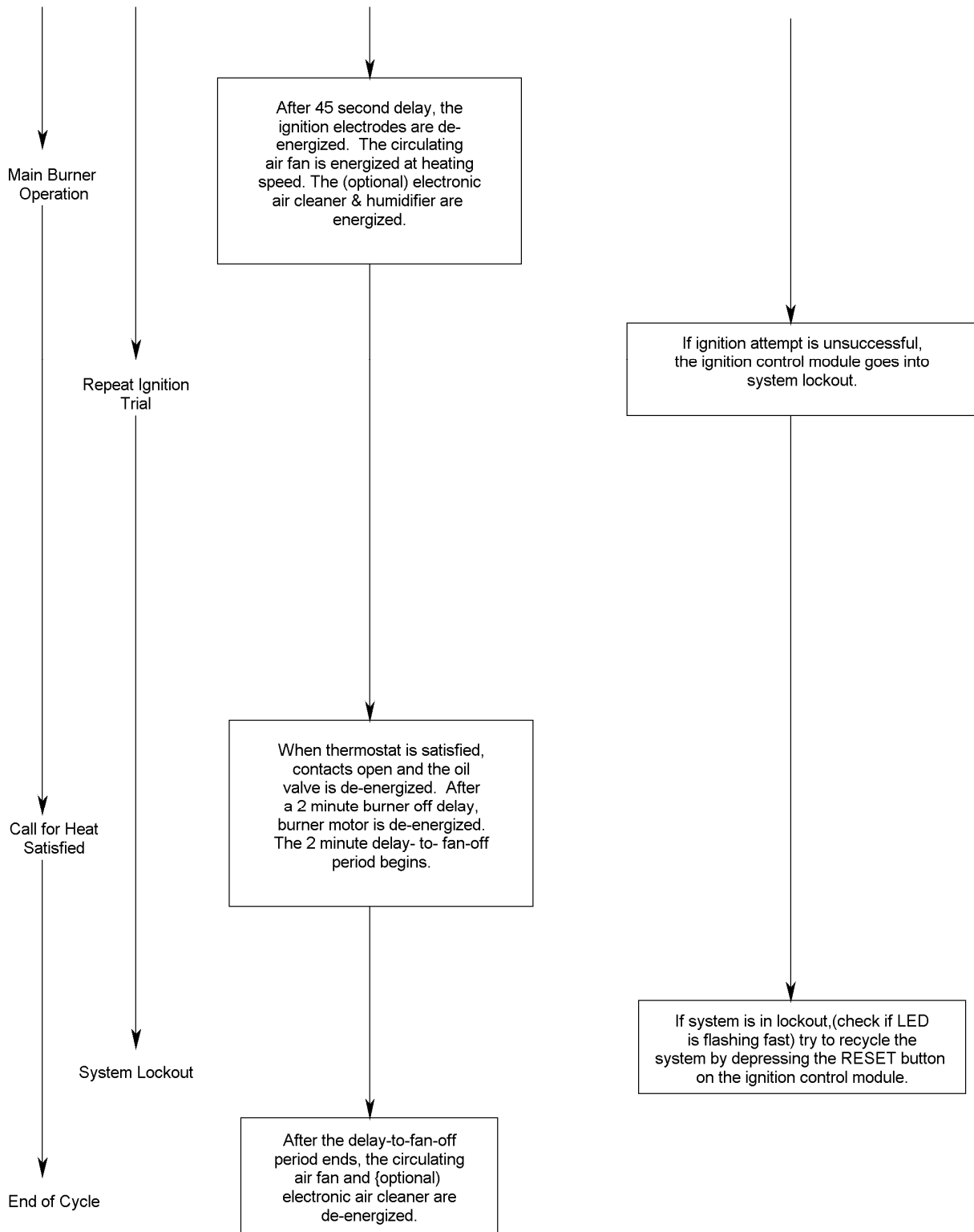

## IX. Trouble Shooting Flow Chart:

### Mode of Operation

Standby  
(At any time the oil  
valve is not energized)

### Control System Action

Continous safe operation check. If  
flame simulation condition present,  
system shuts off oil valve,ignitor,  
and burner motor; activates fast  
flashing LED.

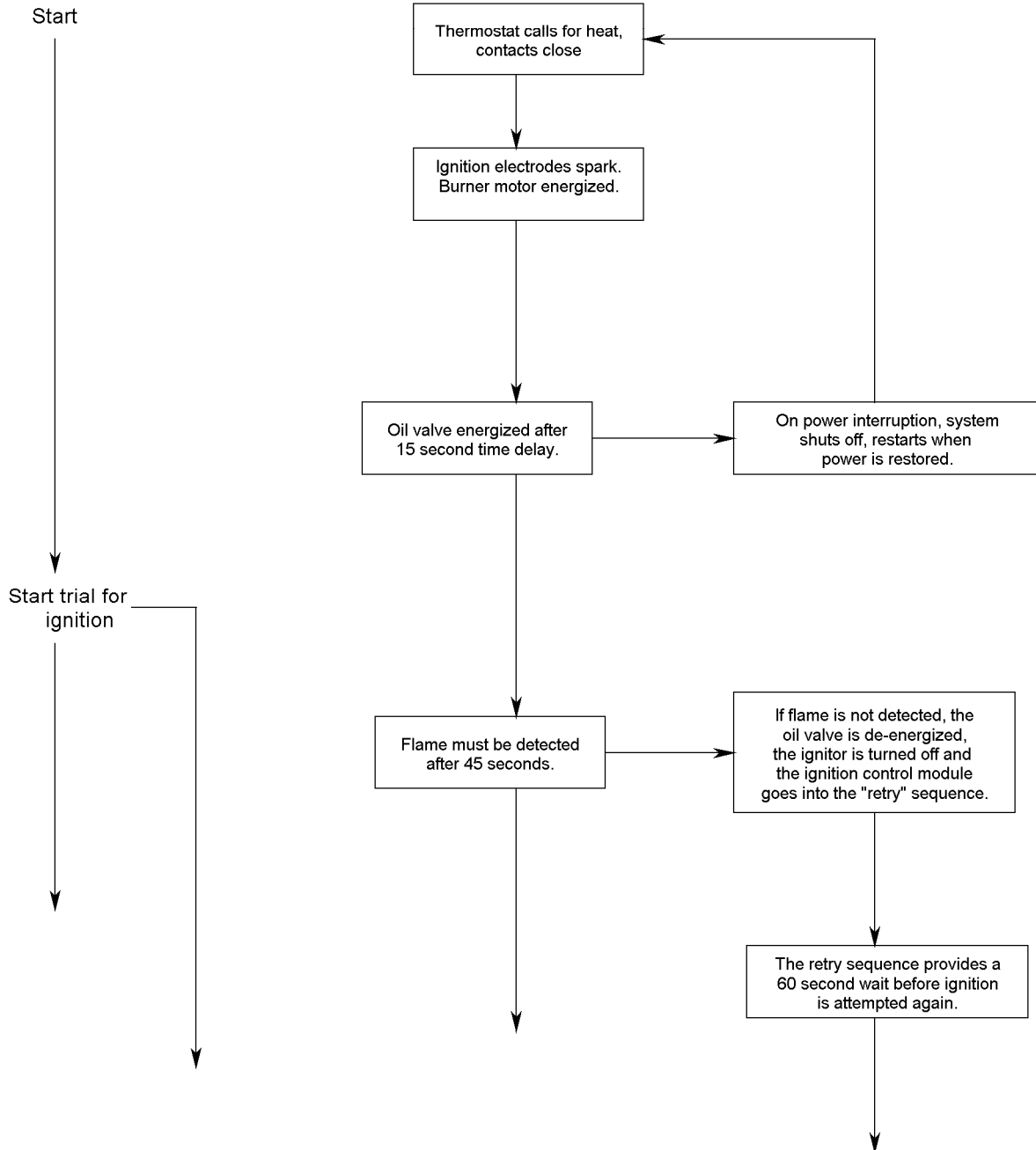

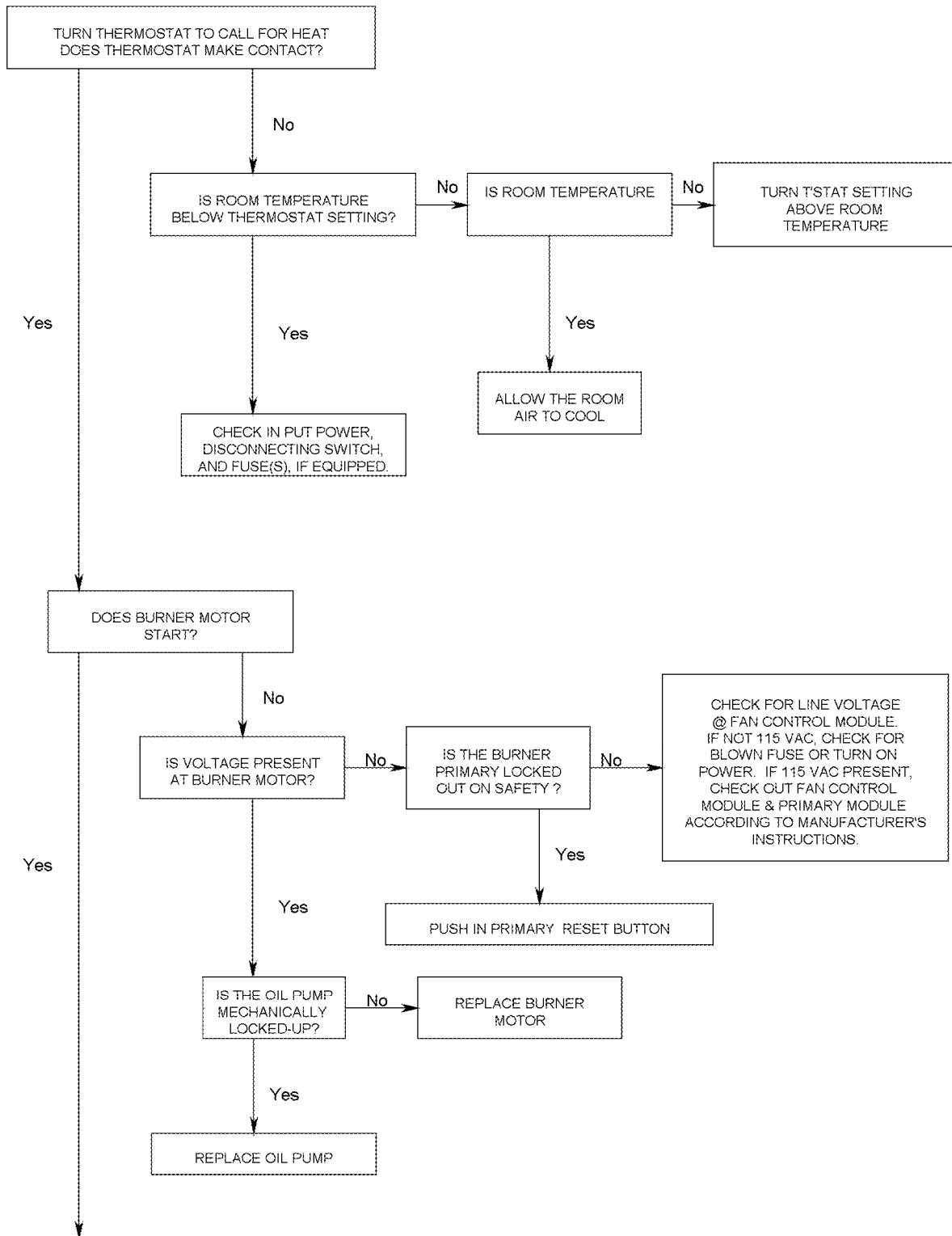

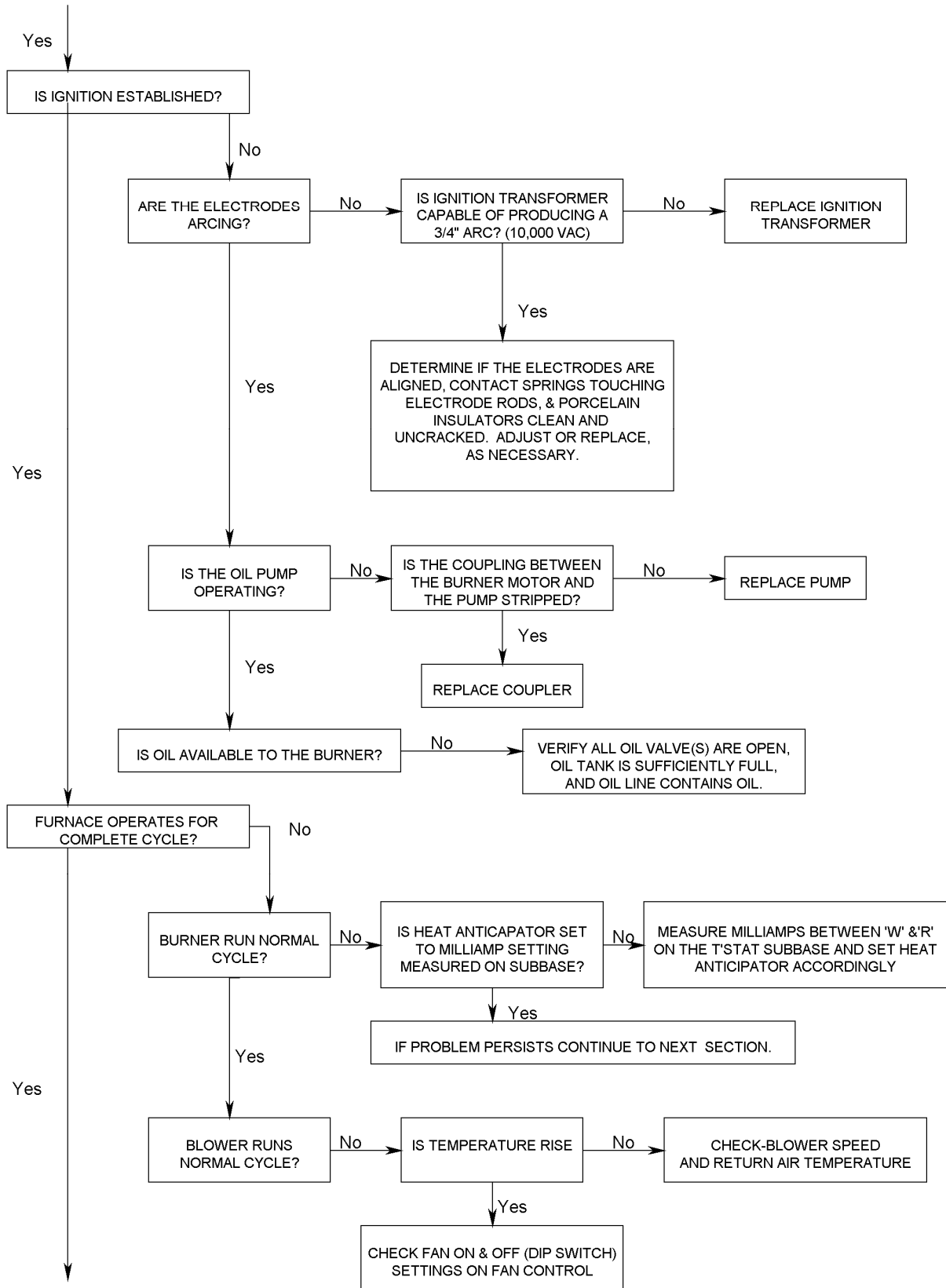

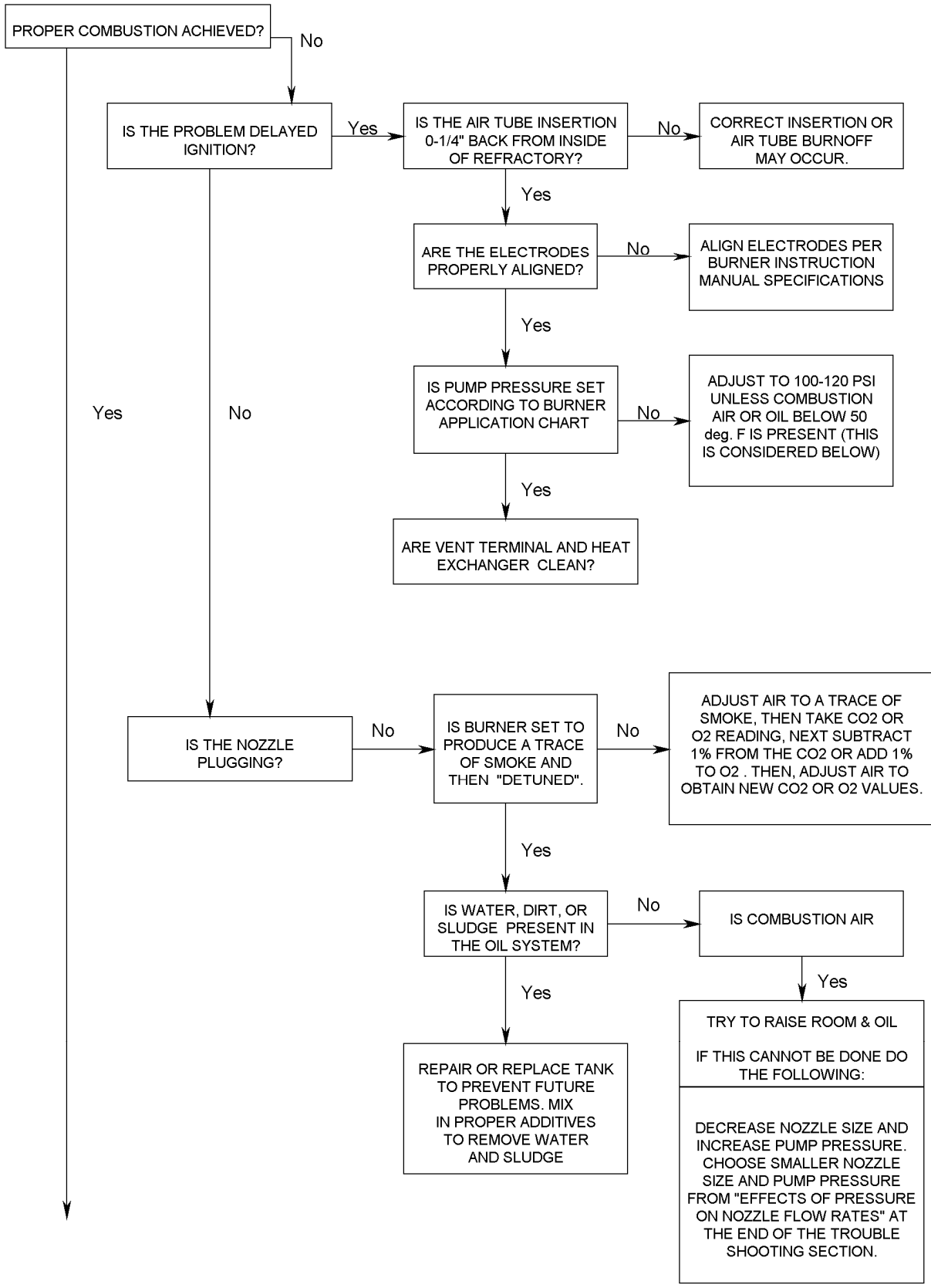

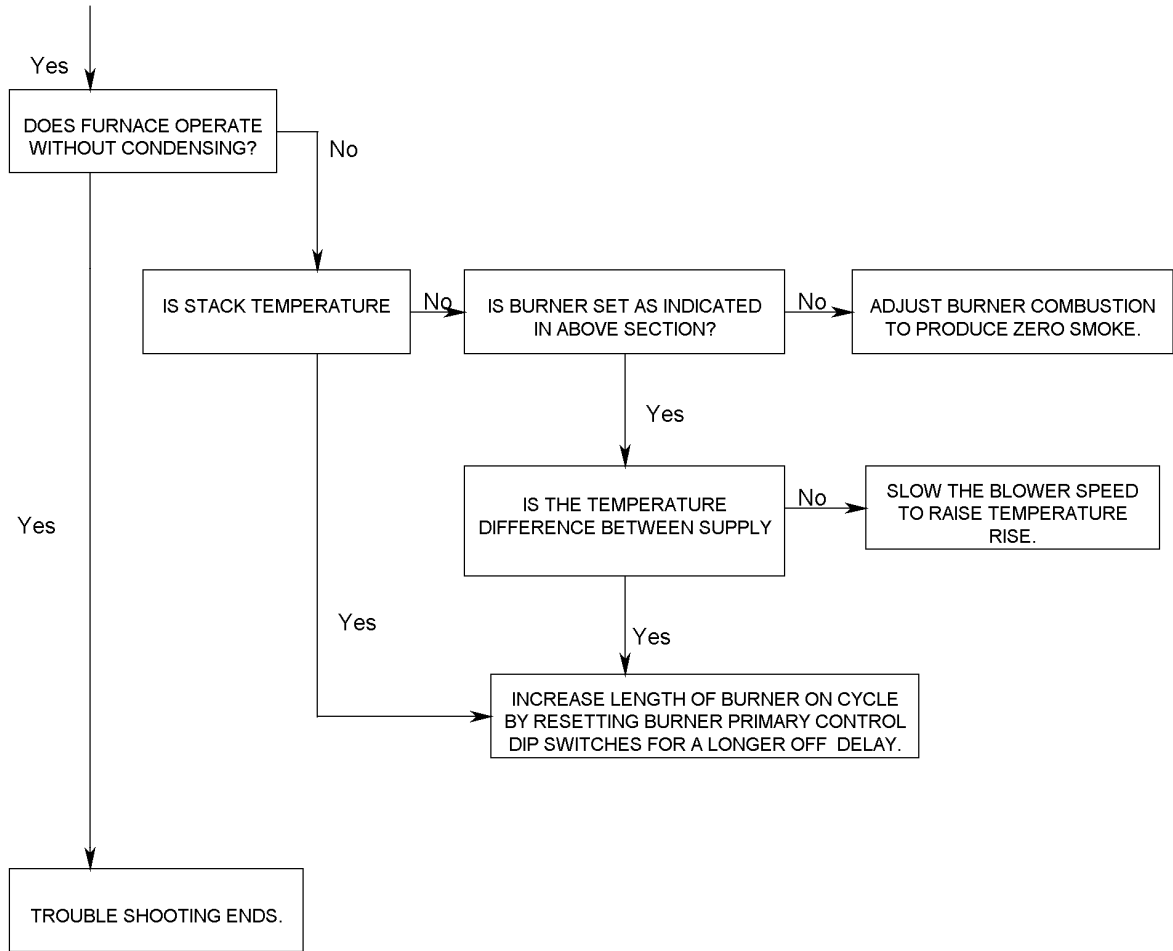

REPEAT PROCEDURE UNTIL TROUBLE FREE OPERATION IS OBTAINED.

### EFFECTS OF PRESSURE ON NOZZLE FLOW RATE

NOZZLE RATING AT 100 PSI	NOZZLE FLOW RATES IN GALLONS PER HOUR (Approx.)		
	80PSI	120PSI	140PSI
.50	0.45	0.55	0.59
.65	0.58	0.71	0.77
.75	0.67	0.82	0.89
.85	0.76	0.93	1.00
.90	0.81	0.99	1.07
1.00	0.89	1.10	1.18
1.10	0.99	1.21	1.30
1.20	1.07	1.31	1.41
1.25	1.12	1.37	1.48

NOZZLE RATING AT 100 PSI	NOZZLE FLOW RATES IN GALLONS PER HOUR (Approx.)		
	80 PSI	120 PSI	140 PSI
1.35	1.21	1.48	1.60
1.50	1.34	1.64	1.78
1.65	1.48	1.81	1.95
1.75	1.57	1.92	2.07
2.00	1.79	2.19	2.37
2.25	2.01	2.47	2.66
2.50	2.21	2.74	2.96
2.75	2.44	3.00	3.24
3.00	2.69	3.29	3.55

**COMBUSTION AND EFFICIENCY TESTING FOR THERMO PRIDE OIL FIRED CENTRAL FURNACES.**

Complete this form for each Thermo Pride furnace installed. Read instruction manual carefully before making tests. Retain this form with furnace.

<b>CUSTOMER</b>	NAME					
	ADDRESS					
	CITY, STATE					
<b>HEATING SYSTEM</b>	BURNER MODEL NO.	BLAST TUBE LGTH. INS.	AIR SHUTTER OPENING % OF MAX. (EST)			
	COMBUSTION CHAMBER	CONDITION	MATERIAL	FURNACE MODEL		
	TYPE OF VENTING SYSTEM					
	<input type="checkbox"/> MASONRY CHIMNEY	<input type="checkbox"/> METAL CHIMNEY	<input type="checkbox"/> SIDEWALL POWER VENTER	<input type="checkbox"/> MASONRY CHIMNEY W/INDUCER		
	<input type="checkbox"/> METAL CHIMNEY W/INDUCER	<input type="checkbox"/> MASONRY CHIMNEY W/METAL LINER				
FUEL LINE FILTER	DRAFT CONTROL		FURNACE SERIAL NUMBER			
<b>COMBUSTION TESTS</b>  (Operate burner at least 10 minutes before starting tests.)		INITIAL INSTALLATION	SERVICE	SERVICE	SERVICE	
	CO2 in stack pipe					
	Draft Over-fire					
	Draft in stack pipe					
	Smoke number					
	Gross stack temp.					
	Furnace room temp.					
	Net stack temp. (Gross stack minus furnace room temp.)					
	Efficiency					
	Nozzle size and spray					
	Oil pump pressure					
	Operation of Controls					
	Burner Safety Controls					
	Check for oil leaks					
	Tests taken by					
	Date					
	NOTES:					
INSTALLER NAME & ADDRESS						



# Appendix – A

## Replacement Parts:

### Replacement Parts for OL6F\*072D\*\*

ITEMS NOT SHOWN:

- 25 DRAFT CONTROL
- 36 DOOR HANDLE PACKAGE
- 39 OFFSET PLENUM STRIP – QTY 2
- 40 OFFSET PLENUM STRIP – QTY 2
- 46\* NOZZLE(S)
- 55\* OIL BURNER
- 28 BLOWER MOTOR HARNESS
- 29 MOTOR POWER HARNESS
- 30 MOTOR CONTROL HARNESS
- 31 VESTIBULE HARNESS

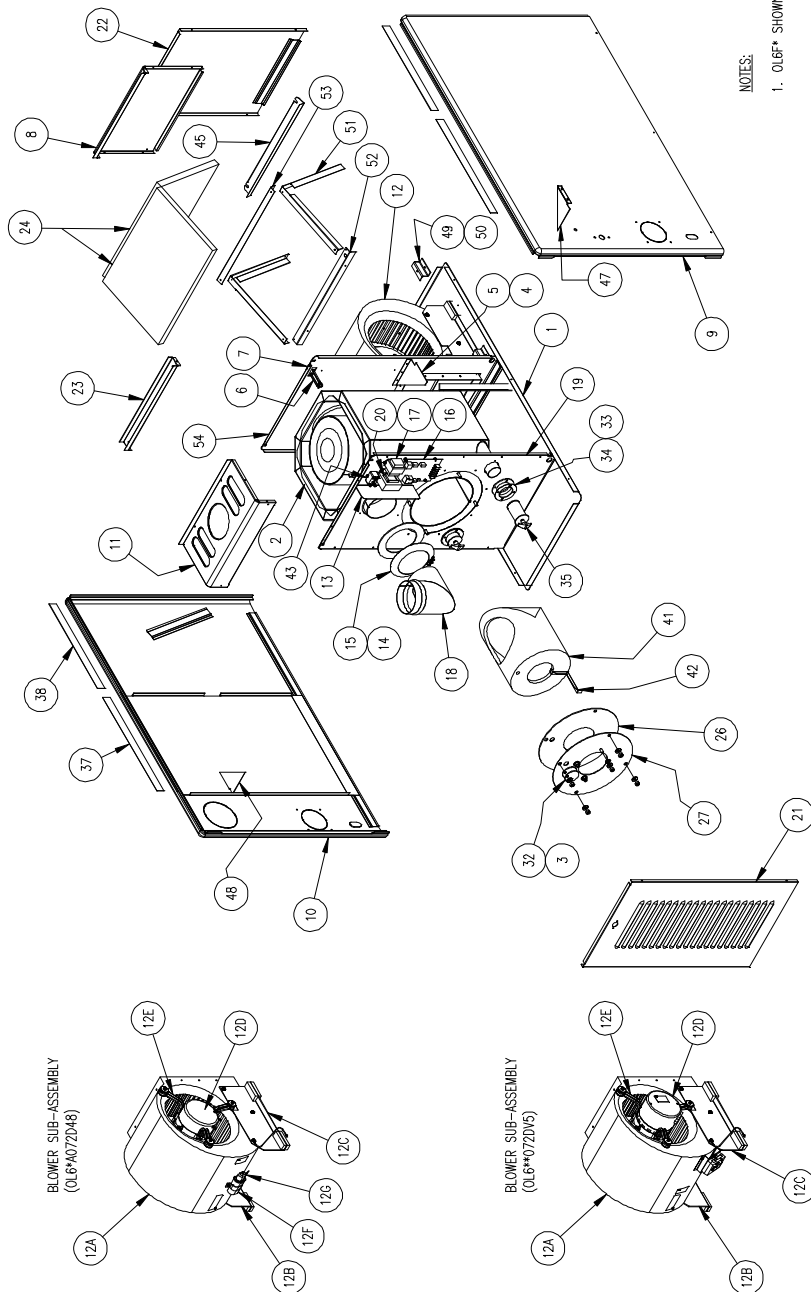

NOTES:  
1. OL6F\* SHOWN, OTHER MODELS MAY VARY SLIGHTLY.

UNIT		OL6FA072D48		OL6FA072DV5	
ITEM	PARTS DESCRIPTION	PART NO.	QTY.	PART NO.	QTY.
1	BASE	28981	1	28981	1
2	HEAT EXCHANGER	39018	1	39018	1
3	CASKET, OVERFIRE DRAFT COVER	330343	1	330343	1
4	BAFFLE, LEFT SIDE CASING	18461	1	18461	1
5	BAFFLE, RIGHT SIDE CASING	18460	1	18460	1
6	LIMIT SWITCH	350817	1	350817	1
7	INSULATION BOOT	350036	1	350036	1
8	TOP REAR PANEL	618994	1	618994	1
9	CASING, RIGHT SIDE	628983	1	628983	1
10	CASING, LEFT SIDE	628982	1	628982	1
11	PANEL, TOP FRONT	619013	1	619013	1
12	BLOWER SUB-ASSEMBLY	50054180	1	50054181	1
12A	BLOWER HOUSING w\ WHEEL	340042	1	340042	1
12A1	BLOWER WHEEL	340108	1	340108	1
12B	BLOWER LEG, LEFT	14828	1	14828	1
12C	BLOWER LEG, RIGHT	14829	1	14829	1
12D	MOTOR, REPLACEMENT KIT	AOPS7652	1	AOPS7499	1
12D1	MOTOR	-	-	350256	1
12D2	16x4 BOX, PROGRAMMED	-	-	AOPS7508	1
12D3	HARNES, 16x4 BOX	-	-	350259	1
12E	MOTOR BRACKET ASSEMBLY	AOPS7670	1	AOPS7670	1
12F	CAPACITOR	350073	1	-	-
12G	INSULATION BOOT	350036	1	-	-
13	HEAT SHIELD	19017	1	19017	1
14	GASKET, FLUE COLLAR	330073	1	330073	1
15	DRAW COLLAR	14121	1	14121	1
16	CONTROL, OIL FURNACE	AOPS8380	1	AOPS8381	1
17	TRANSFORMER	350464	1	350464	1
18	ELBOW, 5"	36050	1	36050	1
19	FRONT SEPARATOR PANEL	618984	1	618984	1
20	INDUCTOR	-	-	350856	1
21	DOOR, FRONT	628996	1	628996	1
22	DOOR, BLOWER ACCESS	628997	1	628997	1
23	TOP CENTER PANEL	618993	1	618993	1
24	FILTER, 14 x 20 x 1	370201	2	370201	2
25	DRAFT CONTROL	370110	1	370110	1
26	CASKET, BURNER MOUNTING PLATE	330212	1	330212	1
27	PLATE, BURNER MOUNTING ASSY	AOPS7648	1	AOPS7648	1
28	HARNES, BLOWER MOTOR	350249	1	-	-
29	HARNES, MOTOR POWER	-	-	350918	1
30	HARNES, MOTOR CONTROL	-	-	350252	1
31	HARNES, VESTIBULE	350250	1	350250	1
32	COVER, OVER-FIRE DRAFT OPENING	18556	1	18556	1
33	GASKET, TRIM PLATE	330215	2	330215	2
34	TRIM PLATE	18553	2	18553	2
UNIT		OL6FA072D48		OL6FA072DV5	
ITEM	PARTS DESCRIPTION	PART NO.	QTY.	PART NO.	QTY.
35	CLEAN-OUT PLUG ASSEMBLY	S0054456	2	S0054456	2
36	DOOR HANDLE PACKAGE	320152	1	320152	1
37	PLENUM STRIP, 19.75"	619016	2	619016	2
38	PLENUM STRIP, 17.75"	618998	2	618998	2
39	PLENUM STRIP, OFFSET, 17.875"	619014	2	619014	2
40	PLENUM STRIP, OFFSET, 19.875"	619015	2	619015	2
41	COMBUSTION CHAMBER	AOPS7492	1	AOPS7492	1
42	CHAMBER RETAINER	18557	1	18557	1
43	-	-	-	-	-
44	-	-	-	-	-
45	FILTER SUPPORT, REAR	18991	1	18991	1
46A	NOZZLES (BECKETT AFG)	380373 (0.50x80B)	1	380373 (0.50x80B)	1
		380375 (0.60x80B)	1	380375 (0.60x80B)	1
		380376 (0.75x80B)	1	380376 (0.75x80B)	1
46B	NOZZLES (RIELLO BF3)	380279 (0.50x80A)	1	380279 (0.50x80A)	1
		380398 (0.60x80A)	1	380398 (0.60x80A)	1
		380258 (0.70x80A)	1	380258 (0.70x80A)	1
46C	-	-	-	-	-
		-	-	-	-
47	BAFFLE, FRONT RIGHT SIDE	19020	1	19020	1
48	BAFFLE, FRONT LEFT SIDE	19021	1	19021	1
49	BLOWER HOLD DOWN, LEFT	14113	1	14113	1
50	BLOWER HOLD DOWN, RIGHT	14114	1	14114	1
51	FILTER SUPPORT, SIDE	19025	2	19025	2
52	REAR SEPR FILTER SUPPORT	19023	1	19023	1
53	FILTER SUPPORT, CENTER	19024	1	19024	1
54	REAR SEPARATOR PANEL	28986	1	28986	1
55A	OIL BURNER, BECKETT AFG	380692 (TP2501)	1	380692 (TP2501)	1
55B	OIL BURNER, RIELLO BF3	380693 (C8511325)	1	380693 (C8511325)	1

# Replacement Parts for OL6R\*072D\*\*

**ITEMS NOT SHOWN:**

- 25 DRAFT CONTROL
- 36 DOOR HANDLE PACKAGE
- 39 OFFSET PLENUM STRIP - QTY 2
- 40 OFFSET PLENUM STRIP - QTY 2
- 46\* NOZZLE(S)
- 55\* OIL BURNER
- 28 BLOWER MOTOR HARNESS
- 29 MOTOR POWER HARNESS
- 30 MOTOR CONTROL HARNESS
- 31 VESTIBULE HARNESS

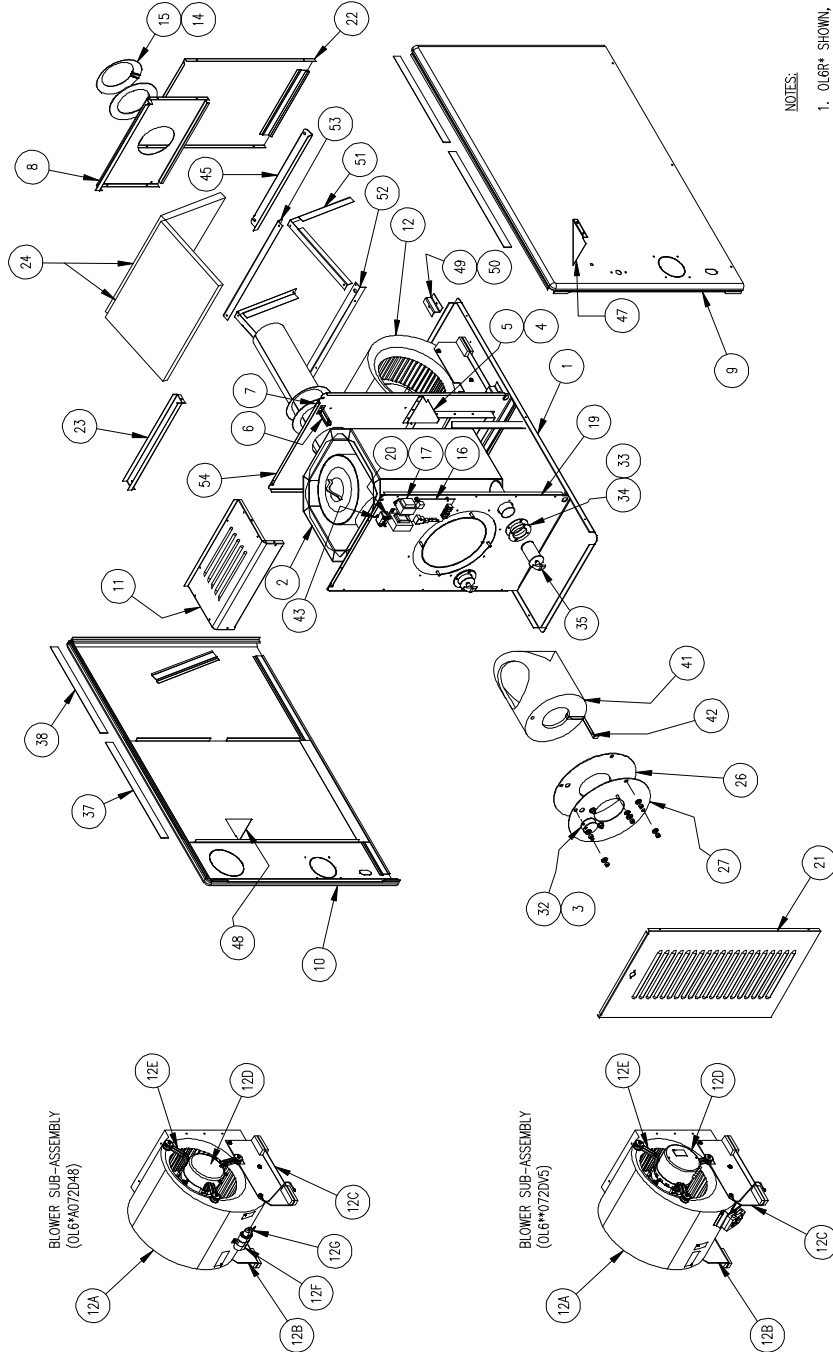

**NOTES:**

1. OL6R\* SHOWN, OTHER MODELS MAY VARY SLIGHTLY.

UNIT		OL6RA072D48		OL6RA072D48		OL6RA072D48		OL6RA072D48		OL6RA072D48	
ITEM	PARTS DESCRIPTION	PART NO.	QTY.	PART NO.	QTY.	PARTS DESCRIPTION	PART NO.	QTY.	PART NO.	QTY.	OL6RA072D48
1	BASE	28981	1	28981	1	DOOR HANDLE PACKAGE	320152	1	320152	1	OL6RA072D48
2	HEAT EXCHANGER	38999	1	38999	1	PLENUM STRIP, 19.75"	619016	2	619016	2	OL6RA072D48
3	GASKET, OVERFIRE DRAFT COVER	330343	1	330343	1	PLENUM STRIP, 17.75"	618998	2	618998	2	OL6RA072D48
4	BAFFLE, LEFT SIDE CASING	18461	1	18461	1	PLENUM STRIP, OFFSET, 17.875"	619014	2	619014	2	OL6RA072D48
5	BAFFLE, RIGHT SIDE CASING	18460	1	18460	1	PLENUM STRIP, OFFSET, 19.875"	619015	2	619015	2	OL6RA072D48
6	LIMIT SWITCH	350953	1	350953	1	COMBUSTION CHAMBER	AOP57492	1	AOP57492	1	OL6RA072D48
7	INSULATION BOOT	350036	1	350036	1	CHAMBER RETAINER	18557	1	18557	1	OL6RA072D48
8	TOP REAR PANEL	618995	1	618995	1						OL6RA072D48
9	CASING, RIGHT SIDE	628983	1	628983	1						OL6RA072D48
10	CASING, LEFT SIDE	628982	1	628982	1						OL6RA072D48
11	PANEL, TOP FRONT	618992	1	618992	1	FLITER SUPPORT, REAR	18991	1	18991	1	OL6RA072D48
12	BLOWER SUB-ASSEMBLY	S0054180	1	S0054181	1	NOZZLES (BECKETT AFG)	380373 (0.50x80B)	1	380373 (0.50x80B)	1	OL6RA072D48
12A	BLOWER HOUSING w\ WHEEL	340042	1	340042	1		380375 (0.60x80B)	1	380375 (0.60x80B)	1	OL6RA072D48
12A	BLOWER WHEEL	340108	1	340108	1		380376 (0.75x80B)	1	380376 (0.75x80B)	1	OL6RA072D48
12B	BLOWER LEG, LEFT	14828	1	14828	1		380279 (0.50x80A)	1	380279 (0.50x80A)	1	OL6RA072D48
12C	BLOWER LEG, RIGHT	14829	1	14829	1		380398 (0.60x80A)	1	380398 (0.60x80A)	1	OL6RA072D48
12D	MOTOR	AOP57652	1	AOP57499	1		380258 (0.70x80A)	1	380258 (0.70x80A)	1	OL6RA072D48
12D1	MOTOR			350256	1						OL6RA072D48
12D2	16x4 BOX, PROGRAMMED			AOP57508	1						OL6RA072D48
12D3	HARNES, 16x4 BOX			350259	1						OL6RA072D48
12E	MOTOR BRACKET ASSEMBLY	AOP57670	1	AOP57670	1						OL6RA072D48
12F	CAPACITOR	350073	1								OL6RA072D48
12G	INSULATION BOOT	350036	1								OL6RA072D48
14	GASKET, FLUE COLLAR	330073	2	330073	2	REAR SEPR FLITER SUPPORT	19023	1	19023	1	OL6RA072D48
15	DRAW COLLAR	14121	2	14121	2	FLITER SUPPORT, CENTER	19024	1	19024	1	OL6RA072D48
16	CONTROL, OIL FURNACE	AOP58360	1	AOP58381	1	REAR SEPARATOR PANEL	28987	1	28987	1	OL6RA072D48
17	TRANSFORMER	350464	1	350464	1	OIL BURNER, BECKETT AFG	380692 (TP2501)	1	380692 (TP2501)	1	OL6RA072D48
18						OIL BURNER, RIELLO BF3	380693 (C8511325)	1	380693 (C8511325)	1	OL6RA072D48
19	FRONT SEPARATOR PANEL	618985	1	618985	1						OL6RA072D48
20	INDUCTOR			350856	1						OL6RA072D48
21	DOOR, FRONT	628996	1	628996	1						OL6RA072D48
22	DOOR, BLOWER ACCESS	628997	1	628997	1						OL6RA072D48
23	TOP CENTER PANEL	618993	1	618993	1						OL6RA072D48
24	FILTER, 14 x 20 x 1	370201	2	370201	2						OL6RA072D48
25	DRAFT CONTROL	370110	1	370110	1						OL6RA072D48
26	GASKET, BURNER MOUNTING PLATE	330212	1	330212	1						OL6RA072D48
27	PLATE, BURNER MOUNTING ASSY	AOP57648	1	AOP57648	1						OL6RA072D48
28	HARNES, BLOWER MOTOR	350249	1								OL6RA072D48
29	HARNES, MOTOR POWER			350918	1						OL6RA072D48
30	HARNES, MOTOR CONTROL			350252	1						OL6RA072D48
31	HARNES, VESTIBULE	350250	1	350250	1						OL6RA072D48
32	COVER, OVER-FIRE DRAFT OPENING	18556	1	18556	1						OL6RA072D48
33	GASKET, TRIM PLATE	330215	2	330215	2						OL6RA072D48
34	TRIM PLATE	18553	2	18553	2						OL6RA072D48
35	CLEAN-OUT PLUG ASSEMBLY	S0054456	2	S0054456	2						OL6RA072D48

# OH6/OD6/OL6 AFG BECKETT BURNER, TP2501 (380692)

## Replacement parts

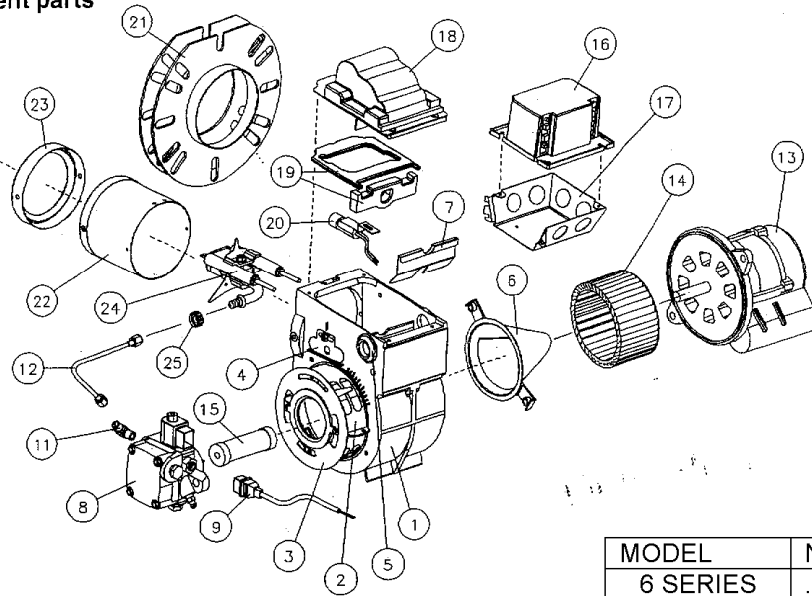

MODEL	NOZZLE SIZE	PART #
6 SERIES	.50 x 80° B	380373
	.60 X 80° B <sup>1</sup>	380375
	.75 X 80° B	380376

ITEM	DESCRIPTION	BECKETT PART #	TP PART #
1	BURNER HOUSING ASSY.	5874GY	
2	AIR BAND ASSY.	5151502	
3	AIR SHUTTER, 4 SLOT, SET @ 7	3709U	380289
4	ESCUTCHEON PLATE	3493	
	SCREW	4292	
5	HOLE PLUG	2139	
6	AIR GUIDE	31231U	
7	LOW FIRING RATE BAFFLE	5880	
8	*PUMP 120PSI	21844	380674
	*SOLENOID	21755	380654
9	VALVE CORD SET	21807U	380653
11	PUMP ELBOW	2256	320815
12	CONNECTION TUBE	5394	380107
13	*MOTOR 1/7 HP 3450 RPM	21805E	380644
14	BLOWER WHEEL 4 ¼ X 2 7/16 TAB	2999	380271
15	*COUPLING	2454	380241
16	*PRIMARY CONTROL	7505B1500	350431
17	ELECTRICAL BOX	5770	
18	*IGNITER W/ GASKETS	51771U	380645
19	IGNITER GASKET KIT	51304	
20	*CAD CELL w/ SOCKET	7006U	350104
21	FLANGE WELDED TO TUBE	N/A	N/A
	GASKET	3616	380270
22	AIR TUBE COMBINATION W/FLG, GUN ASSY & HEAD	58020165	380108
	BLAST TUBE ONLY	AF60YHHSSS	
23	HEAD, F3 W/ SHIELD KIT	360063	380320
24	ELECTRODE NOZZLE ASSY	NL60YH	380706
	*ELECTRODES PAIR	5780	380269
	STATIC PLATE, 3 5/8 U	3384	
25	SPLINED NUT	3666	320121
	BULK HEAD FITTING	3488	320120

<sup>1</sup> Nozzle installed in burner.

9/10/18

EZ1 CARLIN OIL BURNER, 380835

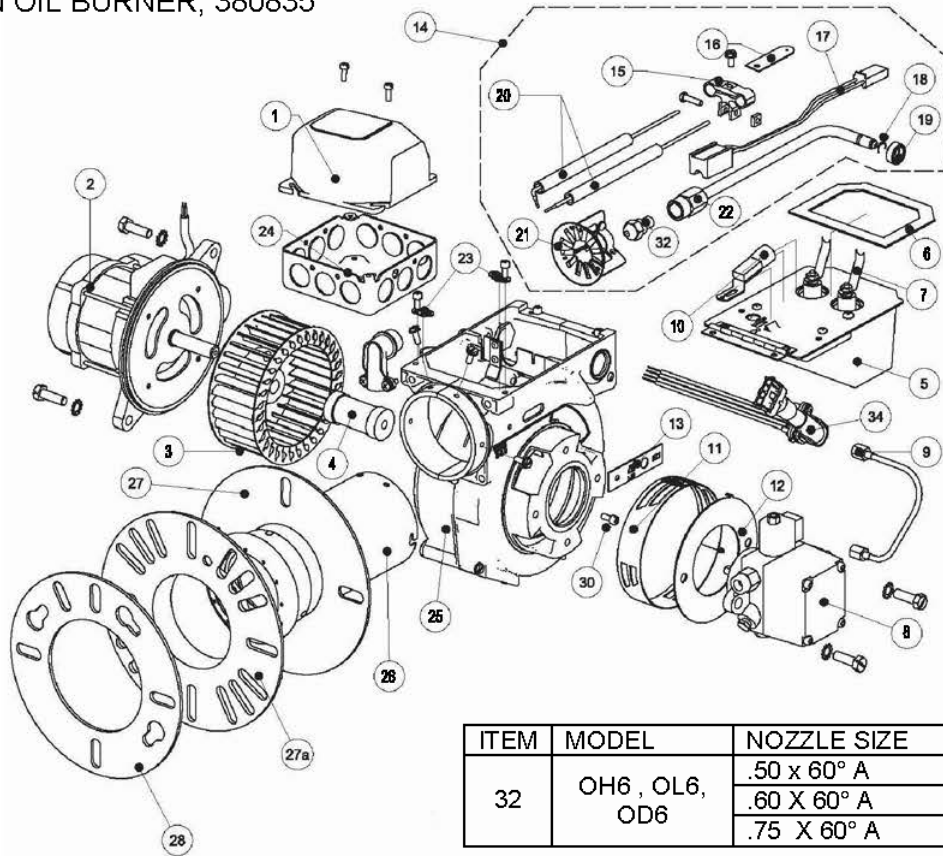

ITEM	MODEL	NOZZLE SIZE	PART #
32	OH6 , OL6, OD6	.50 x 60° A	380393
		.60 X 60° A	380394
		.75 X 60° A	380395

ITEM	DESCRIPTION	CARLIN PART #	TP PART #
1	PRIMARY W/ DISPLAY 70200 10S PRE / 0S POST	70200S	
2	1/6HP PSC MOTOR	98022S	
3	BLOWER WHEEL / FAN	77933S	
4	PUMP COUPLING	75564S	
5	IGNITOR	41000S	
6	IGNITOR BASEPLATE GASKET	40167S	
7	IGNITOR TERMINAL KIT (2 TERM. & NUTS)	24463	
8	PUMP W/SOLENOID 120 PSI	98750S	
	SOLENOID		
	PUMP ELBOW 3/16 FLARE X 1/8 NPT	29926	
9	CONNECTION TUBE	34470	
10	CAD CELL KIT	14407SES	
11 & 12	AIR BAND/AIR SHUTTER KIT @ .5	98055S	
13 & 30	HEADER BAR KIT (7 BARS & SCREW)	98055S	
14	COMBUSTION HEAD ASSY 5"	77958S	
15	ELECTRODE BRACKET	23135	
18 & 19	C RING & THUMB NUT KIT	50624S	
20	ELECTRODE WIRE SET	82768S	
21	RETENTION RING ASSY	77438S	
22	NOZZLE LINE ADAPTER ASSEMBLY	56820	
23	IGNITOR HOLD-DOWN TABS (2 Req.)	44842	
24	ELECTRICAL BOX	44586	
25	HOUSING	50685A	
26	AIR TUBE W/FLANGE	51242	
27	FLANGE	N/A	
28	FLANGE GASKET	40212	

# Riello BF3 C8511325, TP Part# 380693 Parts List

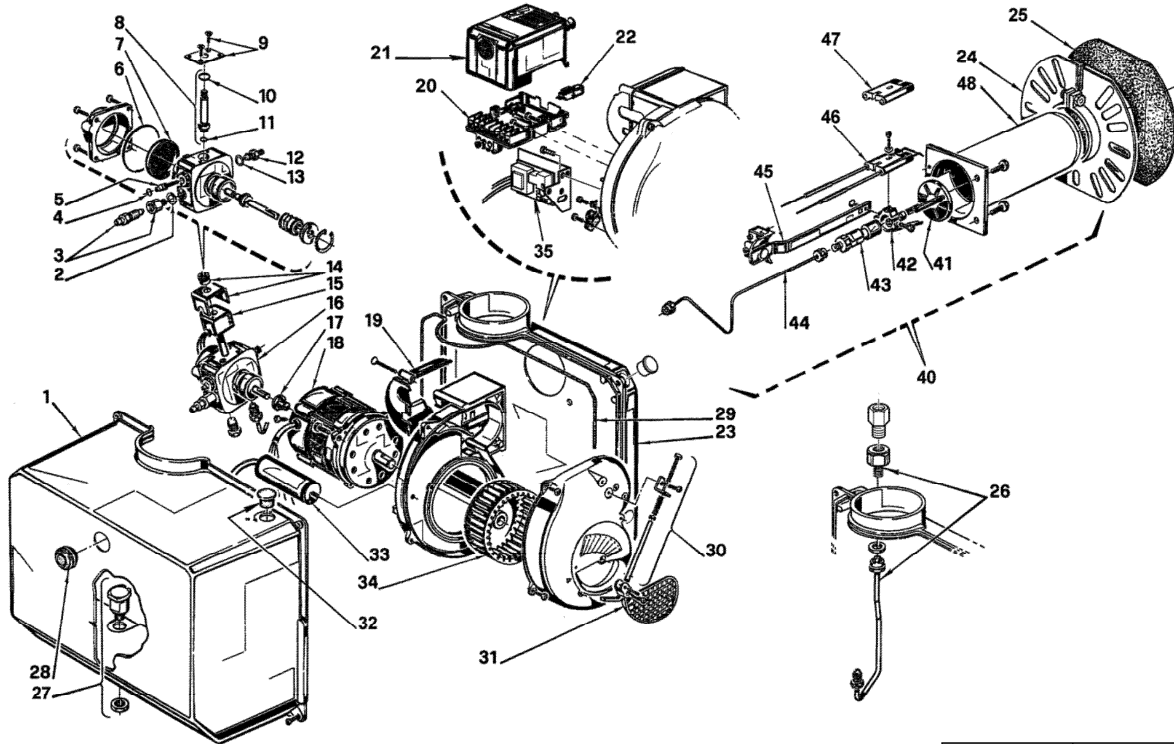

Model	Nozzle Size	Part#
6 Series	.50 X 80°A	380279
	.60 X 80°A	380398
	.70 X 80°A	380258

No.	Description	TP Part #	Riello #	No.	Description	TP Part #	Riello #
1	Burner Cover		3020270	25	Flange Gasket	380270	C6880000
2	Metal Washer 3/8"		3007077	26	Supply Tube & Fitting		3008020
3	Bleeder		3007568		Two Line Kit	380705	C7001026
4	O-Ring - regulator		3007028	27	Drip		3008825
5	Regulator Screw		3007202	28	Cover Opening - Reset		3007627
6	O-Ring - cover		C7010002	29	Gasket – Burner Cover		3007630
7	Pump screen		3005719	30	Air Damper Regulator		3000681
8	Valve Stem		3006925	31	Air Damper		3008021
9	Plate – Valve Stem		3007203	32	Plug		3007706
10	O-Ring – stem upper		3007029	33	Capacitor		3005844
11	O-Ring – stem lower		3007156	34	Fan	380629	3005708
12	Nozzle Outlet Fitting		3007581	35*	AL1009 Post Purge	350383	C7001084
13	Metal Washer 5/8"		3007087	40	Combustion Head	380760	C7001376
14	Coil Bracket & Nut		3006553	41	Turbulator Disc		3006977
15	Coil	380719	3002279	42	Electrode Support		3006966
16	Pump	380633	3007802	43	Nozzle Adapter		3006965
17	Pump Drive Key		3000443	44	Nozzle Oil Tube		3008627
18	Motor	380630	3005843	45	Regulator Assembly		3008633
19	Air Tube Cover Plate		3007315	46	Electrode Assembly	380712	3008630
20	Primary Sub Base		3002278	47	Electrode Porcelain		3005869
21	Primary Control	380449	20010004	48	Air Tube w/ Flange	380710	C7001325
22	Photocell	380628	3002280	NS	Cerafelt Sleeve	380443	C6782000
23	Front Plate		3008078	NS	Gage adapter kit	380689	C7001071
24	Flange (see #48)	NA	NA				

\*Optional

# Appendix – B Wiring Diagrams

## OL6\*A072D48 PSC Wiring Diagram

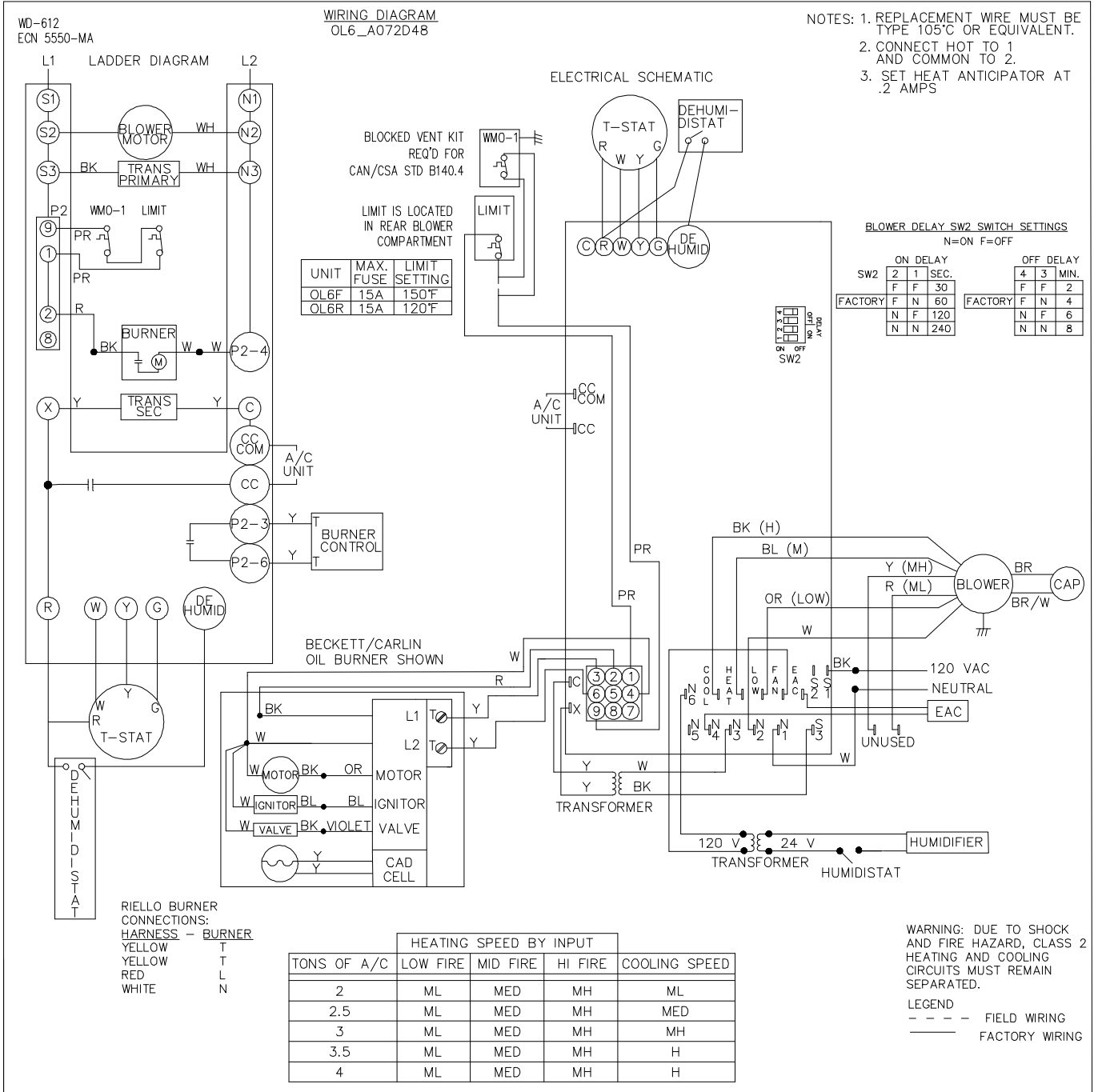



# OL6\*A072DV5 ECM Wiring Diagram

