



Total Recovery for ALL Climates Models TR & TRC



Indoor Energy Recovery Ventilators for Commercial Applications





Commercial ERVS for ALL Climates

Improves Indoor Air Quality

By providing simultaneous exhaust and fresh air supply, S&P reduces the concentration of harmful pollutants in indoor air - an absolute must in schools, offices and smoking environments.

Meets Ventilation Codes for Air Exchange

Provides ample ventilation to meet ASHRAE 62 and the International Mechanical Code that now requires two to three more air exchanges than in the past.

Controls Excess Moisture

Unlike conventional ventilation or basic heat exchangers, S&P moderates not only the temperature but the humidity content of incoming air, limiting humidity swings and associated biologic growths.

Optimum Cold Weather Performance

Recaptures heat otherwise lost to exhaust air while controlling humidity extremes. This greatly reduces the demand on heating equipment - lowering both initial costs and energy bills. Also protects heating coils from freeze damage.

Optimum Warm Weather Performance

Pre-cools and dehumidifies the fresh airstream by transfer of heat and humidity to the exhaust airstream. This greatly reduces air conditioning demand - lowering both initial costs and energy bills. On retrofits, the ventilation rate of existing A/C equipment can be as much as doubled.

Energy Saved = Dollars Saved

S&P's all-weather performance can cut annual energy bills for heating, cooling and dehumidification of ventilation air by 50% or more.

Terms to Know

Sensible Heat

The amount of energy involved in raising or lowering the temperature of air not including any energy required to cause water vapor to change state.

Latent Heat

The amount of energy associated with the humidity (or water vapor content) of an air stream. A drier air stream contains less latent heat and will impose a smaller latent load on the air conditioner.

Enthalpy

The total amount of energy contained in air, the sum of sensible and latent heat.

Balanced Ventilation

A ventilation strategy using both an exhaust air blower and a supply or make-up air blower that does not pressurize or de-pressurize a building.

Air-to-Air Heat Exchanger

Generic term for technologies designed to transfer heat -- and sometimes moisture -- between two air streams.

Heat Recovery Ventilator – HRV

An air-to-air heat exchanger that transfers sensible heat only; no humidity (latent heat) transfer occurs between the two air streams.

Energy Recovery Ventilator – ERV

In Cold Weather, some of the humidity in the inside air is recovered – along with its latent energy. Non-enthalpic heat recovery systems lose that latent energy.

To learn more about the difference between HRVs and ERVs refer to page 3.

HRVs vs. ERVs

The Difference Between ERVs and HRVs

Q: • Energy Recovery Ventilators (ERV) and Heat Recovery Ventilators (HRV) both moderate extremes in ventilation air temperature so what is the difference?

<p>A:</p> <ul style="list-style-type: none"> • ERVs • Transfer BOTH heat AND humidity • Use enthalpic core • S&P's TR and TRC are ERVs 	<p>HRVs</p> <ul style="list-style-type: none"> • Transfer ONLY heat • Use aluminum core or simple plastic cores
---	---

Q: Can ERVs be used in climates subject to cold winters?

A:

- Yes! Because ERVs transfer both heat and humidity they are the perfect choice for any climate. In the winter ERVs:
 - Warm outdoor air close to room temperature
 - Use heat that would otherwise be lost with the exhaust air.
 - Transfer water vapors to moderate extremes in humidity levels
 - Help prevent moisture damage or over-drying of the home.

Q: Why are ERVs better than HRVs?

A:

- HRVs and ERVs are similar in that they both:
 - Improve Indoor Air Quality
 - Moderate extremes in ventilation temperature
 - Use heat that would otherwise be lost with the exhaust air in the winter
 - Provide necessary fresh air while pre-cooling in the summer
- ONLY ERVs have the ability to transfer water vapors or moisture so they:
 - Help prevent over-drying of the home in colder seasons
 - Lessen the demand on the air-conditioning system in warmer seasons
 - Are typically 3x more energy efficient in the summer than products (or units) that transfer only heat (HRVs)

Q: Why are S&P's TR and TRC the Ultimate ERVs?

A:

- S&P's TR and TRCs provide the same benefits as other ERVs on the market.
- Major advantages include:
 - More heat transfer than most HRVs
 - More humidity control than other plate exchangers
 - Simplicity and positive airstream separation not offered by wheel type ERVs
 - 10-year core warranty



The S&P Advantage

With S&P's TR & TRC (total recovery) Series for all climates, stale room air is exhausted and fresh outdoor air is brought back into the house. These two air streams are directed through a highly developed "air-to-air" energy exchange core. The air streams are physically separated by many layers of "plates" so there is no mixing or contamination of the fresh air. The plates are made of an engineered "resin" material that simultaneously transfers heat by conduction and humidity by attracting and moving water vapor from one air stream to the other.

S&P's TR & TRCs moderate extremes in both temperature and humidity, creating a comfortable indoor environment. The unique moisture transfer capability of the S&P core also eliminates condensation and frost build up in most applications. Unlike other ERVs on the market no mechanical or electrical defrost systems are needed, which means higher heat recovery efficiencies, easier installation and more reliable operation.

Contractor Benefits



- Models compatible to any HVAC equipment
- Simple installation
- Mount in any orientation
- May be installed in unconditioned locations like attics and garages
- Easy-to-access field support
- Elimination of callbacks
- "Green Building" compliant

The CORE

- Efficient transfer of heat and moisture
- No liquid is accumulated; no drain pan or defrost mechanism is required!
- Industry best **10-year** warranty

5th Generation Core

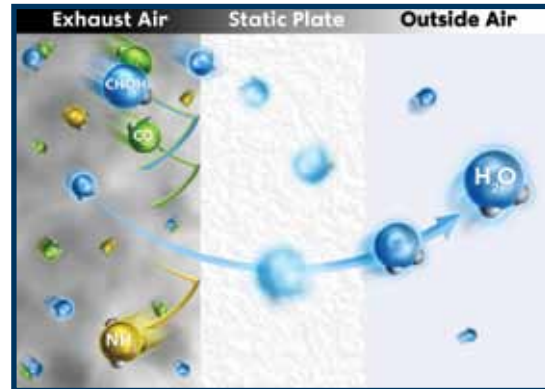
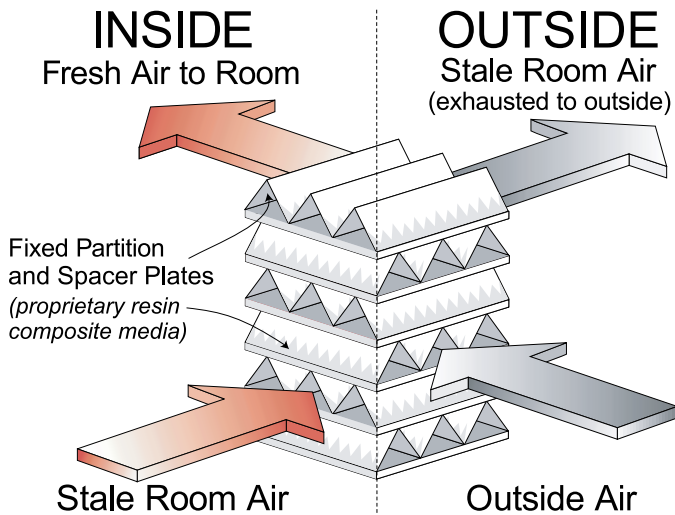

- Contaminated air is exhausted from the building, while the static plate core regulates extremes in humidity

The Warranty

An S&P TR or TRC is protected by a 10-year core warranty (2 years on balance of the unit). This commitment - twice as long as coverage on the best wheel products - means with S&P you can just fit and forget.



Model TR and TRC Sizing

Choosing the Right Size TR by Square Footage

Based on square footage.

If the space is up to:

1500 Sq. Ft. you need a **TR90/TR90G**

2700 Sq. Ft. you need a **TR130**

4000 Sq. Ft. you need a **TR200**

6000 Sq. Ft. you need a **TR300**



Choosing the Right Size TR or TRC by Air Handler Load

For each ton of air handling capacity, 120 CFM of Energy Recovery Ventilation is recommended.

Ton	Capacity 30% Outside Air Fraction in CFM	Model Needed
1.0	120	TR130
1.6	192	TR200
2.0	244	TR300
2.5	299	TR300
3.0	360	TRC500
3.5	415	TRC500
4.0	490	TRC500
5.0	594	TRC800
6.8	810	TRC800



Model TR90/TR90G



Models TR130, TR200 and TR300



Model TRC500



Model TRC800



Residential/Light Commercial Applications

Models TR



Standard Features

- MERV-8 filters
- Less than 1 watt stand-by power consumption
- Transformer/relay package allowing simple on/off control
- Plastic double collars for 6 or 8" direct duct connection (TR300 is 8" only)
- TR90, TR130, TR300 have painted case, low voltage controls, 3' Power cord
- TR90G has galvanized case, line voltage and no line cord
- Integral mounting flange and hanging bracket system
- Fully insulated case
- Large cores for high efficiency
- No condensate pan or drain required
- **10-year** industry best core warranty
- 5-year warranty on balance of unit



Central Exhaust

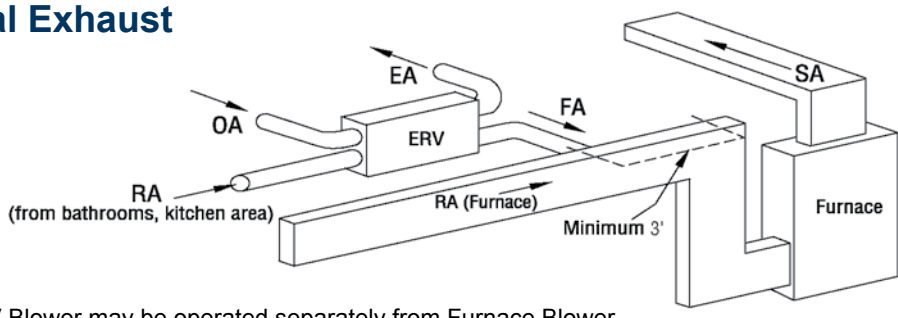

EA: Exhaust Air to outdoors
 OA: Outdoor Air intake
 RA: Room Air to be exhausted
 FA: Fresh Air to inside

Note: ERV Blower may be operated separately from Furnace Blower

General Exhaust

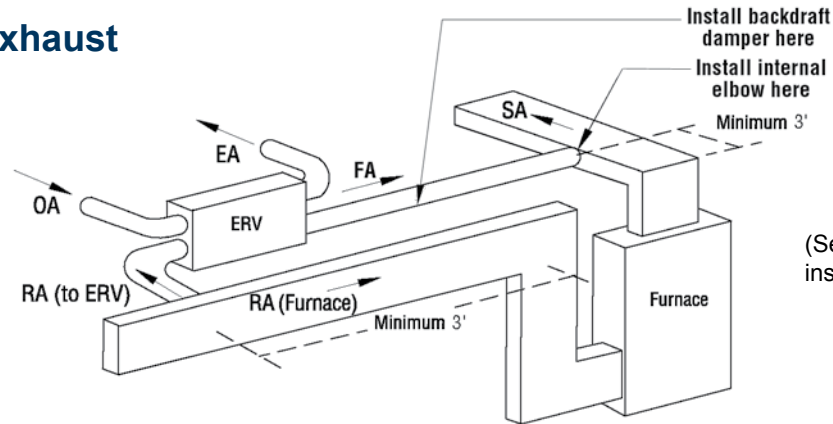

(See manual for additional installation details.)

Note: ERV Blower may be operated separately from Furnace Blower

Model TR Controls



SPTL - Percentage Timer Control

- Primary control for TR90/TR90G, TR130, TR200 and TR300
- Runs unit an adjustable amount of time each hour
- Two wire, low voltage connection to TR
- Meets ASHRAE 62.2 continuous ventilation standards



SPBL - Push Button Point-of-Use Control

- Push button control turns on unit from bathrooms or other intermittent exhaust locations
- 20 minute run-time with one touch
- Push 2x for 40 or 3x for 60 minutes
- Two wire, low voltage connection to SPTL



SFM - Percentage Timer Control with Furnace Interlock

- Alternate primary control for TR90/TR90G, TR130, TR200 and TR300
- Wires to TR unit and either thermostat or furnace control to turn on furnace blower
- Six wire, low voltage connection
- Meets ASHRAE 62.2 continuous ventilation standards



SHW-20 - Dehumidistat

- Rotary dial dehumidistat
- Turn the dial to set desired humidity level
- Designed for convenient installation in bathrooms, kitchen or laundry room
- Dehumidifies when inside air is more humid than the set point
- **Caution:** the outside air must be less humid than the indoor air for this to work.



FT247 - Programmable Fan Timer

- Provides 7 ON and 7 OFF events per day
- LCD display
- Rechargeable battery back-up
- Push button activation



Model TR90/TR90G



Specifications

Ventilation Type: Static Plate, Heat and Humidity Transfer				
Typical Airflow Range: 40-110 CFM				
TR90 - Painted Case, Low Voltage Controls, Line Cord				
TR90G - Galvanized Case, Line Voltage, No Line Cord				
Unit may be mounted in any orientation and in heated or unheated locations				
Number Motors: Two, 0.03 HP each, totally enclosed, thermally protected, 0.35A				
V	Hz	Phase	Input Watts	FLA
120	60	Single	94 @ 69 CFM	0.16
Control Voltage: 24 VAC				
Filters: MERV 8, spun polyester media. 7-12" x 10-1/2" x 1"				
Weight: 36 lbs (unit), 41 lbs (in carton)				
Shipping Dimensions: 28-1/2" L x 21-1/2" W x 14-3/4" H				
Options:				
SPTL - Percentage Timer Control				
SPBL - Push Button Point-of-Use Control				
SFM Percentage Timer Control with Furnace Interlock				
SHW-20 - Dehumidistat Control				

Performance

Airflow CFM	Temp EFF%	Temp Winter%*	Total EFF% Summer*
113	61	55	42
98	64	58	46
85	67	61	49
73	69	33	53
58	72	66	57
40	76	70	61

* Contact Factory for HVI certification report for complete certified rating.

Dimensions

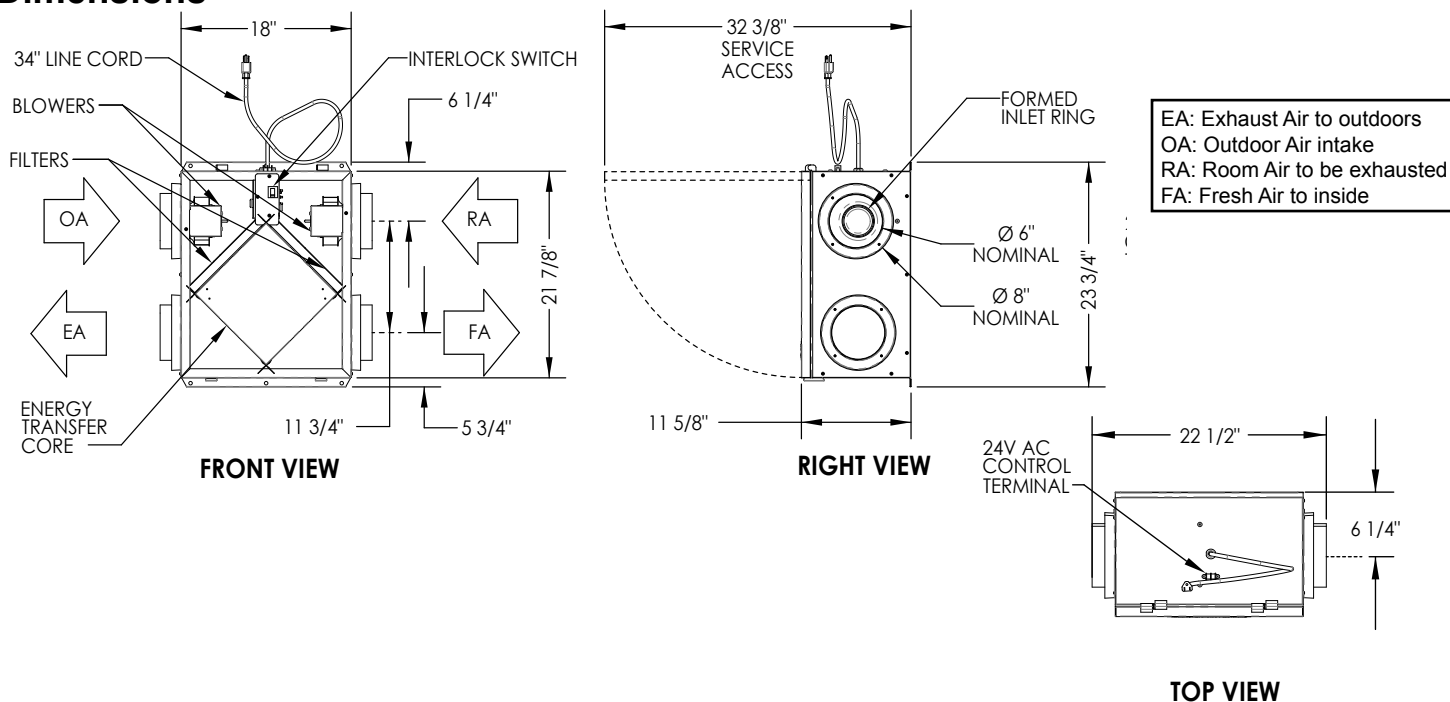

Model TR130



Performance

Airflow CFM	ESP in H ₂ O	Temp EFF%	Total EFF% Winter/Summer*
79	0.60	78	73/60
104	0.50	75	69/55
126	0.40	72	66/50
137	0.30	71	64/48
153	0.20	68	61/45
165	0.10	67	59/43

* Contact Factory for HVI certification report for complete certified rating.

Specifications

Ventilation Type: Static Plate, Heat and Humidity Transfer				
Typical Airflow Range: 50-140 CFM				
Unit may be mounted in any orientation				
Number Motors: One, 0.1 hp				
V	Hz	Phase	Input Watts	FLA
120	60	Single	102 @ 130 CFM	1.2
Control Voltage: 24 VAC transformer / relay package with switched dry contacts				
Filters: MERV 8, spun polyester media. 10-1/2" x 10-1/2" x 1"				
Weight: 49 lbs (unit), 60 lbs (in carton)				
Shipping Dimensions: 32" L x 21" W x 17-1/2" H (in carton)				
Options:				
SPTL - Percentage Timer Control				
SPBL - Push Button Point-of-Use Control				
SFM Percentage Timer Control with Furnace Interlock				
SHW-20 - Dehumidistat Control				

Dimensions

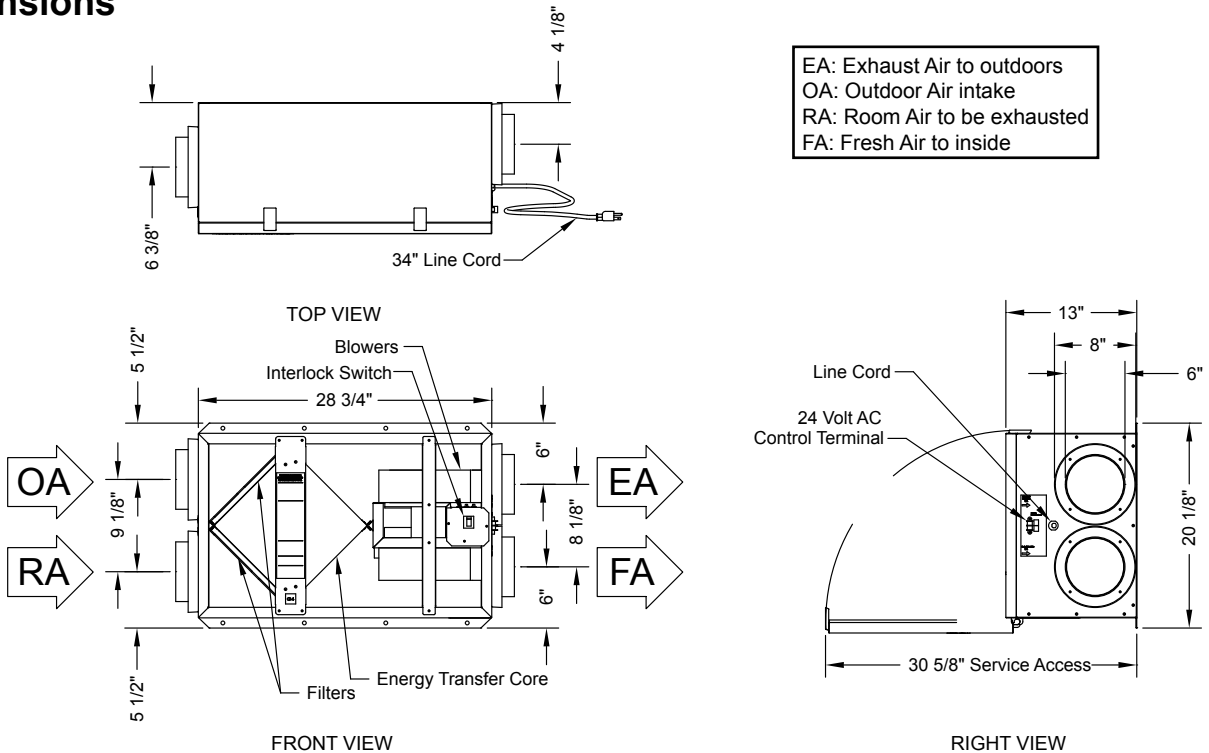



Model TR200



Performance

Airflow CFM	ESP in H ₂ O	Temp EFF%	Total EFF% Winter/Summer*
122	0.70	81	77/64
149	0.60	79	75/61
168	0.50	78	73/59
176	0.40	78	72/59
186	0.30	77	72/58
192	0.20	77	71/57
207	0.10	76	70/56

* Contact Factory for HVI certification report for complete certified rating.

Specifications

Ventilation Type: Static Plate, Heat and Humidity Transfer				
Typical Airflow Range: 100-200 CFM				
Unit may be mounted in any orientation				
Number Motors: One, 0.1 hp				
V	Hz	Phase	Input Watts	FLA
120	60	Single	157 @ 181 CFM	1.5
Control Voltage: 24 VAC transformer / relay package with switched dry contacts				
Filters: MERV 8, spun polyester media. 10-1/2" x 21-3/4" x 1"				
Weight: 70 lbs (unit), 82 lbs (in carton)				
Shipping Dimensions: 32" L x 21-1/2" W x 29" H (in carton)				
Options:				
SPTL - Percentage Timer Control				
SPBL - Push Button Point-of-Use Control				
SFM Percentage Timer Control with Furnace Interlock				
SHW-20 - Dehumidistat Control				

Dimensions

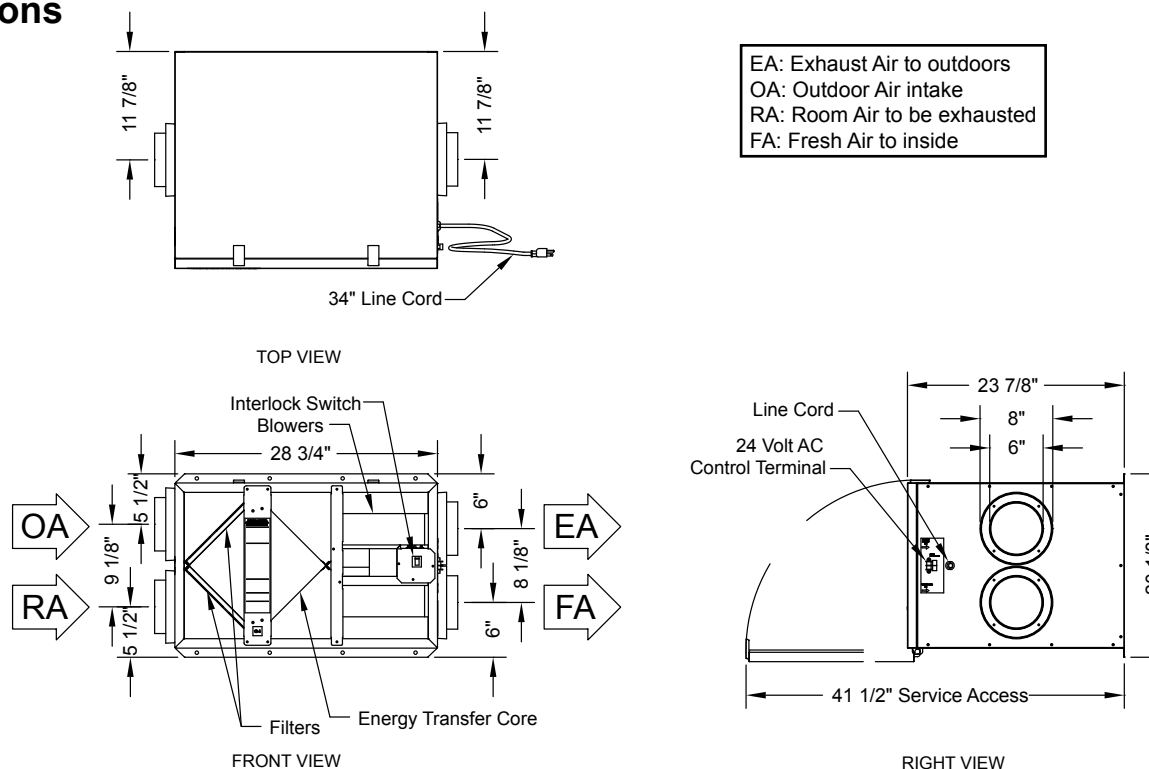

Model TR300



Performance

Airflow CFM	ESP in H ₂ O	Temp EFF%	Total EFF% Winter/Summer*
170	1.0	78	73/59
191	0.9	77	71/57
215	0.8	75	69/55
256	0.7	73	66/51
277	0.6	71	65/49
295	0.5	70	63/47
311	0.4	69	62/46

* Contact Factory for HVI certification report for complete certified rating.

Specifications

Ventilation Type: Static Plate, Heat and Humidity Transfer				
Typical Airflow Range: 150-300 CFM				
Unit may be mounted in any orientation				
Number Motors: One, 0.2 hp				
V	Hz	Phase	Input Watts	FLA
120	60	Single	315 @ 297 CFM	3.3
Control Voltage: 24 VAC transformer / relay package with switched dry contacts				
Filters: MERV 8, spun polyester media. 10-1/2" x 21-3/4" x 1"				
Weight: 72 lbs (unit), 85 lbs (in carton)				
Shipping Dimensions: 32" L x 21-1/2" W x 29" H (in carton)				
Options:				
SPTL - Percentage Timer Control				
SPBL - Push Button Point-of-Use Control				
SFM - Percentage Timer Control with Furnace Interlock				
SHW-20 - Dehumidistat Control				

Dimensions

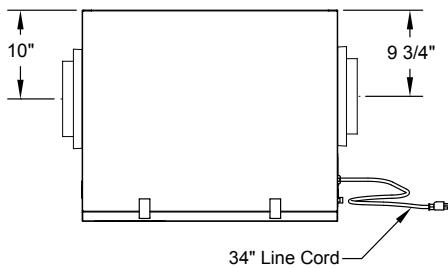

EA: Exhaust Air to outdoors
 OA: Outdoor Air intake
 RA: Room Air to be exhausted
 FA: Fresh Air to inside

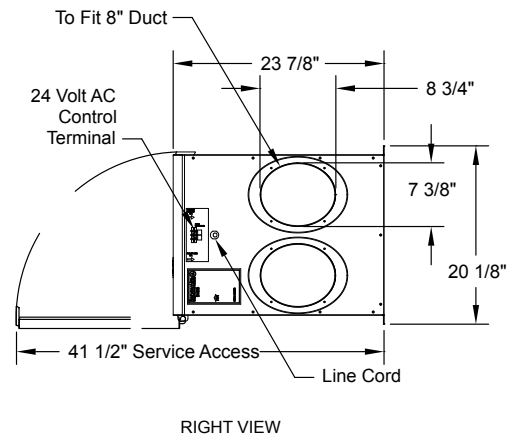
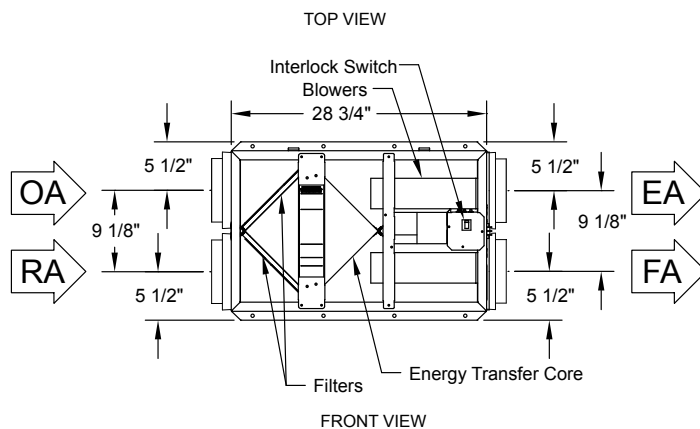



Commercial Applications

Models TRC



Standard Specifications and Features

- AHRI certified performance data for efficiency and cross leakage.
- UL tested flammability and smoke generation that meets NFPA 90A and 90B test standards for commercial applications.
- Easy installation and service.
- Easiest maintenance of any ERV
- 2 MERV-8 filters
- Non-Fused disconnect
- Transformer/relay package allowing simple on/off control
- Access doors for easy access to blowers, core and filters
- Integral mounting flange and hanging bracket system
- 2 Direct Drive, TEFC, Premium Efficient blower motors
- Fully insulated case
- Large cores for high efficiency
- No condensate pan or drain required
- **10-year** industry best core warranty
- 2-year warranty on balance of unit

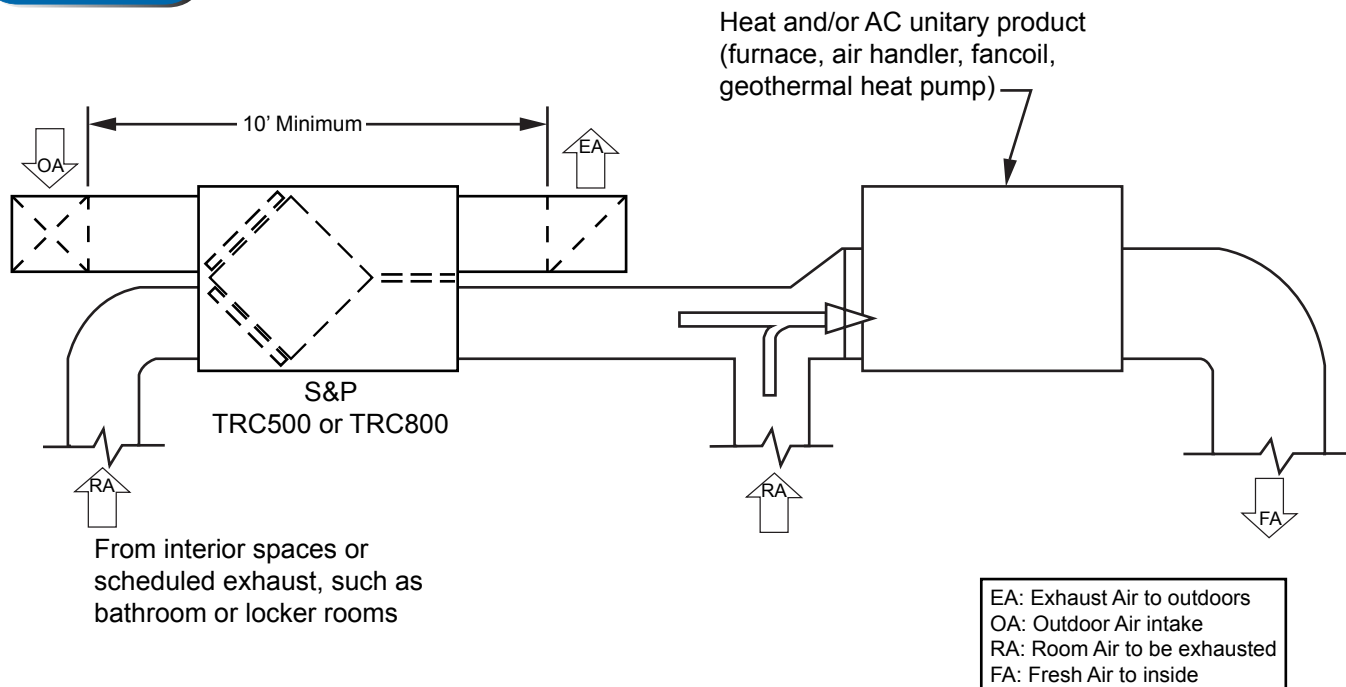

Model TRC Controls

These controls are intended to turn S&P commercial energy recovery ventilation systems on and off at appropriate times. Specification, installation and set-up is an easy process. The TRC units come standard with a 24 volt transformer/relay package for easy interface with all controls.

It is not necessary that S&P controls be used to operate S&P units. A wide range of controls or building automation systems may be used. Additionally, TRC800 units are “VFD Ready” as a standard feature.

The S&P residential (TR) units have their own line of compatible controls that are not intended to operate S&P commercial (TRC) units.

STC7D-W - Digital Time Clock - Wall Mount



- Up to 8 on/off cycles per day or 56 per week
- 24 VAC power requirement
- Battery back-up
- Fits any 4" x 4" electrical box

SMC-C - Motion (Occupancy) Control - Ceiling Mount



- Passive infrared sensor
- Adjustable time-off delay to 30 minutes
- 24 VAC power requirement
- Covers up to 1500 sq. ft. floor space
walking motion coverage up to 22 foot radius

SCO2-W - Carbon Dioxide Control - Wall Mount



- Adjustable control from 600-2000 PPM
- Digital display
- 24 VAC power requirement
- Computer/BAS interface for information and control
- Self calibrates during periods of low occupancy

SHW-20 - Dehumidistat



- Rotary dial dehumidistat
- Turn the dial to set desired humidity level
- Designed for convenient installation in bathrooms, kitchen or laundry room
- Dehumidifies when inside air is more humid than the set point
- **Caution:** the outside air must be less humid than the indoor air for this to work.

FT247 - Programmable Fan Timer



- Provides 7 ON and 7 OFF events per day
- LCD display
- Rechargeable battery back-up
- Push button activation



Model TRC500



Performance

Airflow CFM	ESP in H ₂ O	Watts	Temp EFF%	Total EFF% Winter/Summer*
225	1.25	335	81	76/66
338	1.00	420	77	71/61
380	0.90	470	75	69/59
450	0.65	550	73	66/56
540	0.25	640	70	62/52
575	0.00	690	69	61/51
600	-0.25	735	68	60/50

* At AHRI 1060 standard conditions
(see certified data on page 18 for core components.)
Note: Watts is for the entire unit.

Specifications

Ventilation Type: Static Plate, Heat and Humidity Transfer					
Typical Airflow Range: 200-540 CFM					
AHRI 1060 Certified Core: One L85					
Airflow Rating Points (for AHRI): 450 CFM and 338 CFM					
Motors: One, 0.6 hp (Single Phase)					
V	Hz	Phase	FLA	Min. Cir. Amps	Max. Overcurrent Protection Device
115	60	Single	7.0	8.8	15
208-230	60	Single	3.5	4.4	15
Standard Features: Non-Fused Disconnect 24 VAC Transformer/Relay Package					
Filters: Two total, MERV 8, 2" pleated, 14" x 20" nominal size					
Weight: 141 lbs (unit), 160 lbs (in carton) 200 lbs (on pallet), up to 3 units on 40 lb pallet					
Shipping Dimensions: 48" L x 41" W x 18" H (in carton) 55" L x 42" W x 22" H (on pallet)					

Model TRC500

Dimensions

EA: Exhaust Air to outdoors
 OA: Outdoor Air Intake
 RA: Room Air to be exhausted
 FA: Fresh Air to inside

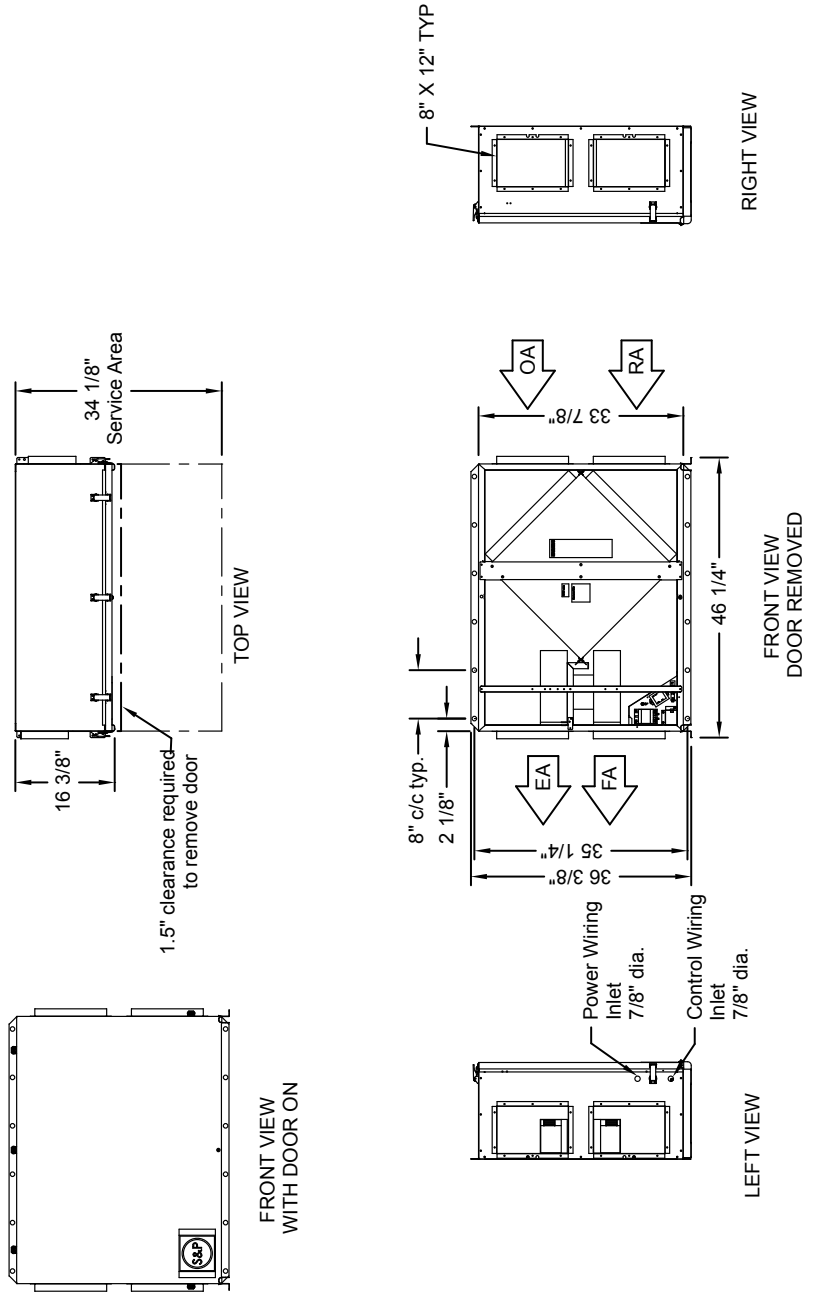



Model TRC800



Performance

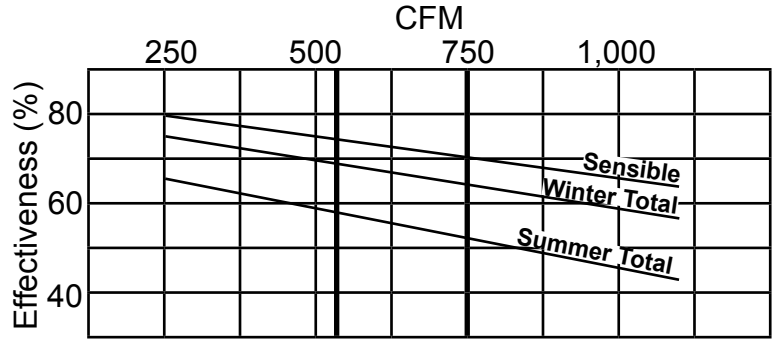

* At AHRI 1060 standard conditions
(see certified data on page 18 for core components.)

Specifications

Ventilation Type: Static Plate, Heat and Humidity Transfer					
Typical Airflow Range: 250-925 CFM					
AHRI 1060 Certified Core: One L125-00					
Airflow Rating Points (for AHRI): 750 CFM and 563 CFM					
Number Motors: Two direct drive blower/motor packages					
V	Hz	Phase	FLA (per motor)	Min. Cir. Amps	Max. Overcurrent Protection Device
115	60	Single	9.0	20.3	25
208-230	60	Single	4.5	10.1	15
Standard Features: Non-Fused Disconnect 24 VAC Transformer/Relay Package					
Filters: Two total, MERV 8, 2" pleated, 20" x 20" nominal size					
Weight: 211 lbs (unit), 300 lbs (shipping weight, on pallet)					
Shipping Dimensions: 62" L x 48" W x 40" H					

Airflow Performance

Motor HP Phase	External Static Pressure (Inches Water Column)						
	0.0	0.25	0.5	0.75	0.9	1.25	1.5
0.75	970 CFM	925 CFM	860 CFM	795 CFM	750 CFM	635 CFM	480 CFM
Single Phase	1,490 Watts	1,375 Watts	1,270 Watts	1,160 Watts	1,090 Watts	950 Watts	825 Watts

Note: Watts is for the entire unit (two motors).

Model TRC800

Dimensions

EA: Exhaust Air to outdoors
 OA: Outdoor Air intake
 RA: Room Air to be exhausted
 FA: Fresh Air to inside

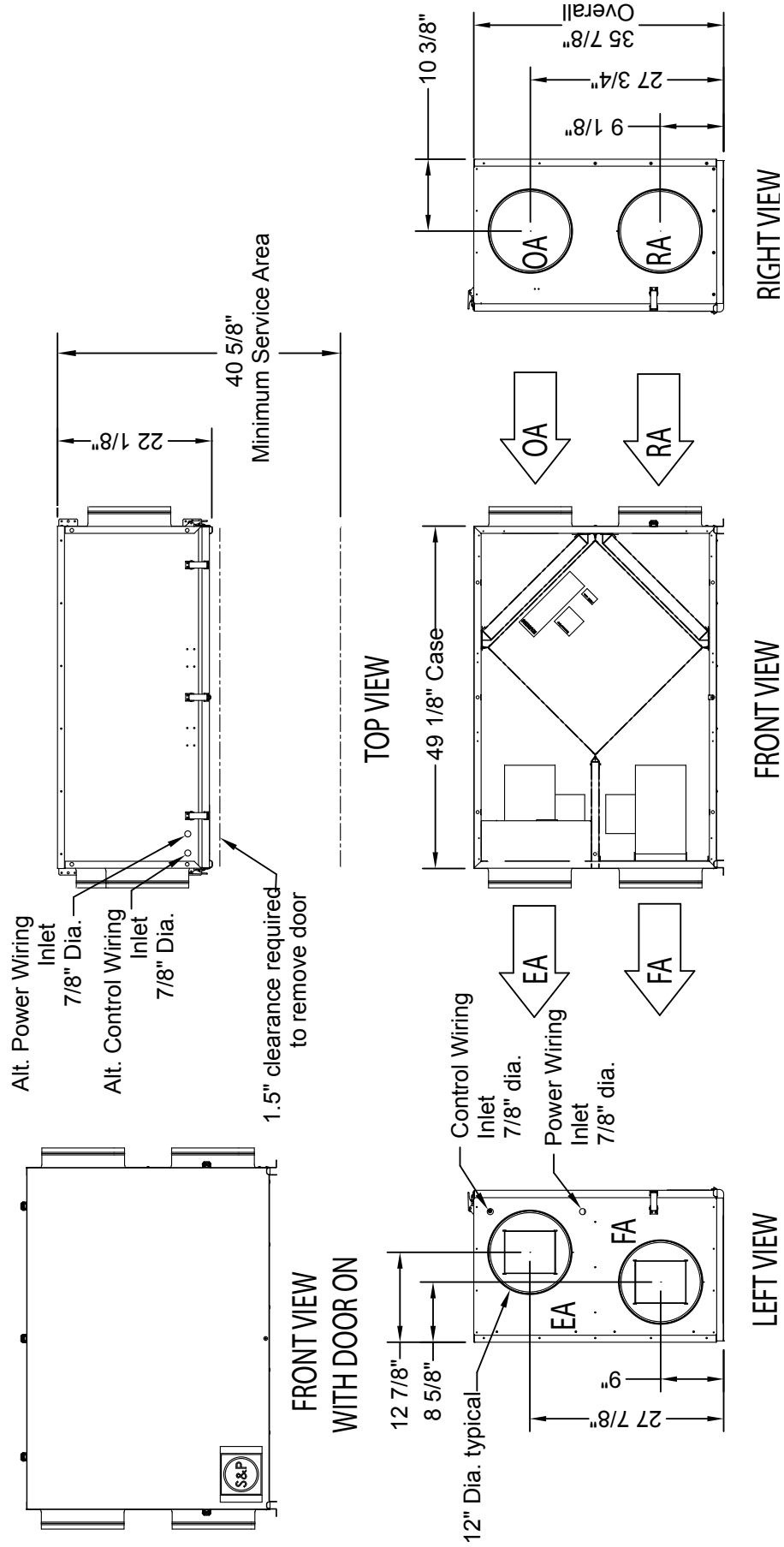



AHRI 1060-2005 - Certified Performance

AHRI-1060 Certified Performance - Model Number L85-G5 (used in TRC500)													
Type		Tilt Angle			Nominal Airflow				Pressure Drop				
Plate		N/A			100% - 450 SCFM 75% - 338 SCFM				0.6 in. H ₂ O 0.5 in. H ₂ O				
Leakage Ratings					Thermal Effectiveness Ratings at 0" Pressure Differential								
	Pressure Differential	EATR	OACF	Purge Angle or Setting	Nominal Airflow		Sensible	Latent	Total	Net Airflow	Net Sensible	Net Latent	Net Total
Test 1	-1 in. H ₂ O	1.0%	1.00	N/A	450 CFM	Heating	73%	53%	66%	450 CFM	73%	53%	66%
Test 2	0 in. H ₂ O	0.0%	1.02	N/A	338 CFM	Cooling	73%	46%	56%	338 CFM	73%	46%	56%
Test 3	1 in. H ₂ O	0.0%	1.05	N/A		Heating	77%	60%	71%		77%	60%	71%
					Cooling		77%	52%	61%		77%	52%	61%

AHRI-1060 Certified Performance - Model Number L125-G5 (used in TRC800)													
Type		Tilt Angle			Nominal Airflow				Pressure Drop				
Plate		N/A			100% - 750 SCFM 75% - 563 SCFM				0.65 in. H ₂ O 0.45 in. H ₂ O				
Leakage Ratings					Thermal Effectiveness Ratings at 0" Pressure Differential								
	Pressure Differential	EATR	OACF	Purge Angle or Setting	Nominal Airflow		Sensible	Latent	Total	Net Airflow	Net Sensible	Net Latent	Net Total
Test 1	-1 in. H ₂ O	1.0%	1.00	N/A	750 CFM	Heating	71%	52%	64%	750 CFM	71%	52%	64%
Test 2	0 in. H ₂ O	0.0%	1.02	N/A	563 CFM	Cooling	71%	43%	53%	563 CFM	71%	43%	53%
Test 3	1 in. H ₂ O	0.0%	1.05	N/A		Heating	75%	59%	69%		75%	59%	69%
					Cooling		75%	50%	59%		75%	50%	59%

NOTE: SCFM = Standard Cubic Feet per Minute OACF = Outdoor Air Correction Factor EATR = Exhaust Air Transfer Ratio N/A = Not Applicable

Energy recovery components certified in accordance with AHRI Standard 1060-2005. Actual Performance in packaged equipment may vary.



S&P: A Global Strategy - A Local Policy

S&P was founded in the locality of Ripoll (Spain) in 1951 by the engineers Eduard Soler and Josep Palau. From the beginning they had the clear vision that the future would depend on the expansion abroad, at first towards Europe, then to continue in the rest of the world markets.

philosophy

The principle philosophy on which S&P was based on and continues to base its projects are:

Own technology: Key to any S&P projects, the concept has to be strong and consolidated over time. It is necessary that it is based on creativity and innovation to provide products, that offer benefits to the market. S&P has registered, throughout its history, over 140 patents, on more than 20 industrial models and some 120 on utility models.

Internationalization and Growth: It was clear that the guarantee of the future of the company was to open up to the world and to enter into new markets with high levels of competitiveness. This requires both a constant improvement of the existing products and development of new innovative designs. At present S&P is a world leader in ventilation, with production centers in Europe, America and Asia. A powerful distribution structure, through subsidiaries and exclusive distributors, allows S&P to be present in all the world markets, giving coverage and excellent service.

Self-financing: One of the strengths of S&P has been the constant growth and the policy of reinvestment of profits in a continuous technology improvement in the field of research & development, production and commercialization. This has allowed S&P to be a self-financed company with total independence in the decision making.



basic pillars

On the philosophical principles of the project of S&P, there are some basic pillars on which the company is sustained:

Personal development: At S&P we promote the human factor encouraging teamwork, the contribution of ideas, internal promotion and training. We encourage the delegation of responsibilities, giving confidence and full respect of the individual with the aim of ensuring that people feel part of a common project and are reflected by the Company's values.

Excellence in the management: Factors we consider fundamental are dedication, honesty, self demand, and determination to do all things well, to achieve the levels of quality and service required by our customers.

Research: In the R+D+I department, more than 60 engineers and technicians, equipped with the most modern design systems, work to obtain products with the best features. Sophisticated software allows the simulation of the behavior of the equipment already in the process of design. The goal is clear: A commitment to our customers to achieve the quality levels they expect from us.

Product: Today the S&P catalog offers a range of ventilation products, both commercial and residential, with solutions for every need. With constant development work to ensure our customers and end users, not only the choice of the best model, but also the required design for ease of installation, and a full guarantee.

Quality: At S&P the contribution to the final quality begins in the design of the products. From that point on, quality remains at the center of the development throughout the company, finishing in the after-sales service. For this reason, our company is recognized all over the world for its high level of reliability of all the products offered in our catalog.

Respect for the environment: A policy that was not respectful with the environment would be incompatible with the S&P philosophy. Our actions today implicates us deeply in the legacy that we are going to leave our children.

Customer service: In a market as competitive as the current one it is simply not enough to produce excellent quality. A company should offer products and a wide range of services for its customers and consultants. At S&P this principle is very clear.



S&P USA Ventilation Systems, LLC S&P Canada Ventilation Products, Inc.

6393 Powers Avenue Jacksonville, FL 32217 P. 904-731-4711 · F. 904-737-8322 www.spvg-northamerica.com	5600 Ambler Drive Mississauga, ON L4W 2K9 - Canada Tel. 416-744-1217 · Fax 416-744-0887 www.solerpalaucanada.com
---	---

Soler&Palau 
Ventilation Group