



SOUTHWARK METAL MANUFACTURING COMPANY

Philadelphia, PA • Greenville, SC • Indianapolis, IN • Southaven, MS • Fremont, NE • Caldwell, ID

Corporate Headquarters: 2800 Red Lion Road, Philadelphia PA 19114

tel: (800) 523-1052 • fax (800) 722-2076 • www.southwarkmetal.com

SUBMITTAL DRAWING

**STRAIGHT 90° ELBOW
(MODEL NO: ST90)**

Product Availability

Diameter	30 Ga	28 Ga	26 Ga	24 Ga
3"	x	x	x	
4"	x	x	x	x
5"	x	x	x	x
6"	x	x	x	x
7"	x		x	x
8"	x		x	x
9"	x		x	x
10"	x		x	x
12"	x		x	x
14"			x	x
16"			x	x
18"			x	x
20"			x	x
22"			x	x
24"			x	x

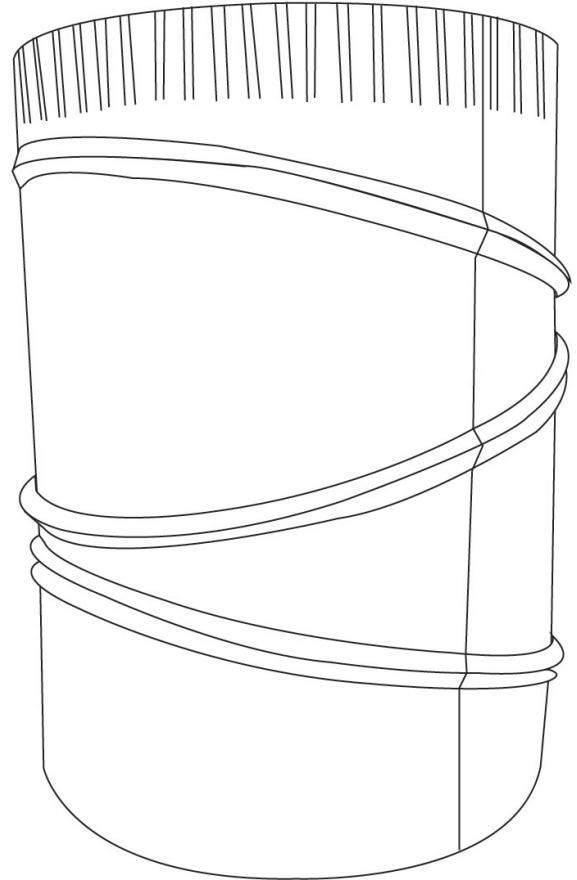
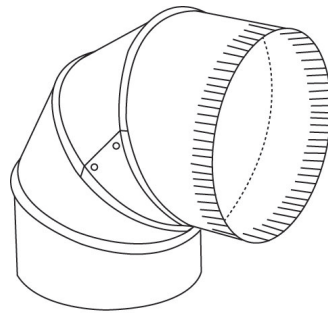

SMACNA Gauge Requirements for Galvanized Steel

Duct Diameter	2" w.g. max Positive Pressure	Duct Diameter	2" w.g. max Negative Pressure
3" - 8"	28 Ga	6" - 10"	28 Ga
9" - 14"	26 Ga	12"	26 Ga
15" - 26"	24 Ga	14" - 16"	24 Ga
		18" - 20"	22 Ga
		22" - 26"	20 Ga

From SMACNA HVAC Duct Construction Standards Metal and Flexible, 2nd Ed (1995); 3.3 & 3.8

NOTES

- Material: Hot Dipped Galvanized Steel per ASTM A653 CS Type B
- Crimp and bead male connection and straight female connection
- 1" crimp length
- Adjustable to move into 90° elbow
- 1/2" overlap for riveting using 1/8" rivets
- RL-2 rivet seam; meets +/- 4" w.g. pressure
- Meets +/- 2" W.G. pressure overall
- 3" through 20" diameters = 4 pc. assembly
- 22" through 24" diameters = 5 pc. assembly

JOB NAME: _____
 LOCATION: _____
 ARCHITECT: _____
 ENGINEER: _____
 CONTRACTOR: _____

DATE: 01/03/13 SW-SLPNE SD-0004

Elbow
 MODEL NO: 90