



# SimpleComfort® SC2000N/L SC2001N/L

SC2000N/L **R C R H W Y O B G**  
Terminations  
SC2001N/L **R C W Y O B G**

## SINGLE STAGE HEAT/COOL OR HEAT PUMP

*Non-Programmable*

**Simple control for year-round comfort.** This easy-to-operate comfort command center allows you to match temperature to your family's lifestyle. Attractive, extra-rugged, highly reliable and accurate, this thermostat's elegant design will look and perform like new for years to come.



Also available in vertical design.  
See Ordering Info. for details



- Single-stage heat/cool
- Single-stage heat pump
- New ICM patented Thermal Intrusion Barrier
- Simple operation
- Large LCD display (backlight available; see ordering information)
- Accuracy:  $\pm 1^{\circ}\text{F}$
- Manual changeover
- Adjustable temperature differential
- Compatible with gas, oil and electric systems
- 4- or 5-wire compatible (SC2001N/L)
- Millivolt compatible (SC2000N/L)
- Low battery indicator (SC2000N/L)
- No batteries required (SC2001N/L)
- Freeze protection feature
- High temperature "run away" heat protection
- Zone compatible
- Soft touch controls



# SC2000N/L



# SC2001N/L



- One-stage heat/one-stage cool
- Single-stage heat pump
- Gas, oil or electric systems
- Millivolt compatible (SC2000N/L)
- Zone compatible
- 4- or 5-wire compatible (C is optional for non-heat pump systems)
- Manual changeover

## Non-Programmable Single-Stage Heat/Cool or Heat Pump Battery (SC2000N/L) or Hardwired (SC2001N/L)

### Specifications

#### Electrical Rating:

- 24 VAC (18-30 VAC)
- 1 amp maximum per terminal
- 3 amp maximum total load
- 30-minute power backup (SC2001N/VN)
- Easy access terminal block

#### Temperature Control Ranges:

- 45°F to 90°F, Accuracy: ±1°F

#### System Configurations:

- Single-stage heat, single stage cool or single stage heat pump, gas, oil, electric

#### Terminations:

- SC2000N/L: RC, RH, W, Y, O, B, G
- SC2001N/L: R, C, W, Y, O, B, G

#### Ordering Information\*:

- Without backlight: SC2000N, SC2001N\*
- With backlight: SC2000L, SC2001L\*

\* For vertical models, substitute the "N" or "L" suffix with "VN" or "VL". Pricing varies per model.

### Dimensions

Horizontal design

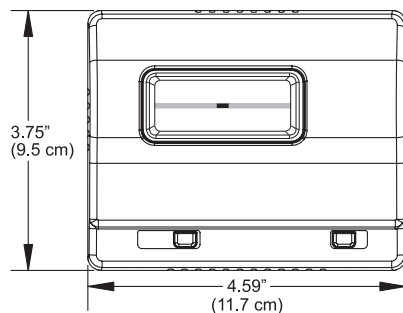

Vertical design

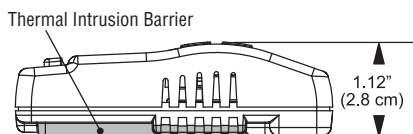
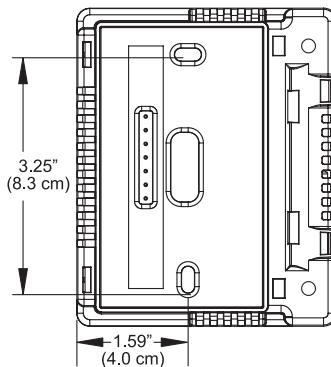
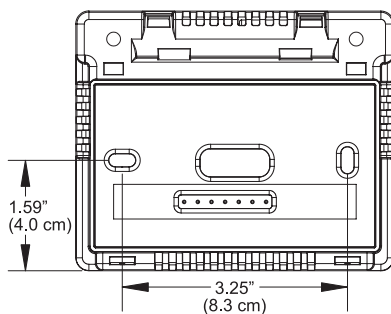
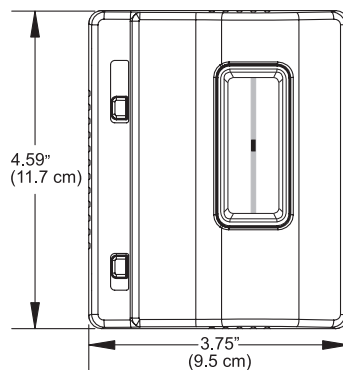

Specifications subject to change without notice.

## NEW Thermal Intrusion Barrier

Exclusive, patented insulation technology eliminates thermal drift caused by wall effect.

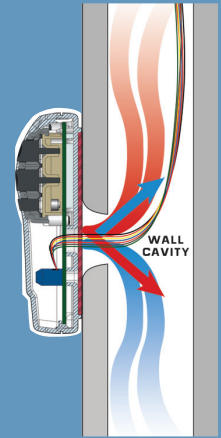

If you like this model, be sure to try out these other thermostats from ICM Controls!

### SimpleComfort® PRO Series – Innovation and technology that simplifies installation and increases profitability!

- Flexible 7-day, 5-2-day and 5-1-1-day programming (programmable models)
- ICM's patented Thermal Intrusion Barrier
- ICM's patent-pending SimpleSet™ Target Programming technology
- Large display with backlight
- Permanent memory
- Auto or manual changeover
- Field adjustable calibration
- Configurable remote sensor compatible
- Keypad lockout
- Soft-touch controls

### Programmable Thermostats

- SC5010 – One-stage heat/cool or heat pump, dual powered
- SC5011 – One-stage heat/cool or heat pump, hardwired
- SC5211 – Two stage heat pump, hardwired
- SC5811 – Two-stage heat/cool or heat pump, hardwired
- SC5812 – Three-stage heat/two-stage cool or heat pump, dual fuel compatible, hardwired
- SC5813 – Three-stage heat/ two-stage cool, or single or dual compressor heat pump, hardwired

### Non-Programmable Thermostats

- SC4010 – One-stage heat/cool or heat pump, dual powered
- SC4011 – One-stage heat/cool or heat pump, hardwired
- SC4211 – Two stage heat pump, hardwired
- SC4811 – Two-stage heat/cool or heat pump, hardwired
- SC4812 – Three-stage heat/two-stage cool or heat pump, dual fuel compatible, hardwired