

LPM-07

NATURAL GAS TO LP GAS CONVERSION KIT

INSTALLATION INSTRUCTIONS

ATTENTION INSTALLING PERSONNEL

As a professional installer, you have an obligation to know the product better than the customer. This includes all safety precautions and related items.

Prior to actual installation, thoroughly familiarize yourself with this Instruction Manual. Pay special attention to all safety warnings. Often during installation or repair, it is possible to place yourself in a position which is more hazardous than when the unit is in operation.

Remember, it is your responsibility to install the product safely and to know it well enough to be able to instruct a customer in its safe use.

Safety is a matter of common sense...a matter of thinking before acting. Most dealers have a list of specific good safety practices...follow them.

The precautions listed in this Installation Manual are intended as supplemental to existing practices. However, if there is a direct conflict between existing practices and the content of this manual, the precautions listed here take precedence.



DESCRIPTION

This natural gas to L.P. gas conversion kit allows the 36G22 [B1282628, 36J22 (0151M00037)] and VR-8215 (0151M00013) series gas valves to be used on L.P. gas applications. This conversion kit is for use on all single stage maximum regulation valves.

Required Tools for Kit Installation	
2	Pipe wrenches, properly sized to accommodate the gas piping and connectors
1	7/16" box wrench or socket wrench
1	1/4" nut driver
1	1/4" regular (flatblade) screwdriver
1	Manometers to read inlet & outlet pressure of the gas valve (minimum range: 0" - 20" W.C.)
1	3/16" Allen wrench
2	1/8" NPT hose barb
	Pipe joint compound or pipe thread tape that is approved for use with L.P. gas
	Gas leak detection solution, like a soap and water solution. Always wipe the solution from the joints when testing is complete.



WARNING

TO AVOID THE POSSIBILITY OF EXPLOSION OR FIRE, NEVER USE A MATCH OR OPEN FLAME TO TEST FOR LEAKS.

Prior to performing this conversion refer to the National Fuel Gas Code (ANSI Z223.1) or in Canada, CAN/CGA-B149.2-M91 to ensure that the installation is in compliance with those and all local codes.

PLEASE READ AND FOLLOW THESE INSTRUCTIONS CAREFULLY.



WARNING

TO AVOID THE POSSIBILITY OF EXPLOSION OR FIRE, NEVER USE A MATCH OR OPEN FLAME TO TEST FOR LEAKS.



WARNING

THE MANUFACTURER WILL NOT BE RESPONSIBLE FOR ANY INJURY OR PROPERTY DAMAGE ARISING FROM IMPROPER SERVICE OR SERVICE PROCEDURES. THIS L.P. (LIQUID PETROLEUM) CONVERSION KIT **MUST** BE INSTALLED BY A QUALIFIED SERVICE PERSON OR AGENCY IN ACCORDANCE WITH THE MANUFACTURER'S INSTRUCTIONS AND ALL APPLICABLE CODES AND REQUIREMENTS OF THE AUTHORITY HAVING JURISDICTION.

FAILURE TO FOLLOW THESE INSTRUCTIONS EXPLICITLY MAY CAUSE A FIRE, EXPLOSION OR THE PRODUCTION OF CARBON MONOXIDE, WHICH CAN CAUSE PROPERTY DAMAGE, PERSONAL INJURY OR DEATH.

IF YOU INSTALL OR PERFORM SERVICE ON THIS UNIT, YOU ASSUME RESPONSIBILITY FOR ANY PERSONAL INJURY OR PROPERTY DAMAGE WHICH MAY RESULT. MANY JURISDICTIONS REQUIRE A LICENSE TO INSTALL OR SERVICE HEATING AND AIR CONDITIONING EQUIPMENT.

KIT CONTENTS

Using the following parts list, ensure that all parts included in this list are present and in an undamaged condition.

Quantity	Part Number	Description
1	B10259108	Conversion Label
1	B1880007	Spring Kit for White-Rodgers 36G22 & 36J22 valves
1	0163M00078	Spring Kit for Honeywell VR8215 Valve
1	B40899125	1.25mm Burner Orifice
1	IO-817	Installation Instructions
1	0151K00000S	Pressure Check Kit Valve



CONTENTS

Important Information	2
Conversion Instructions - WR 36G22 or 36J22 Valves	3
Conversion Instructions - HW VR8215 Valve	5
NOx Screen Removal	6
Non-Condensing Furnaces & Package Gas-Electric	6

IMPORTANT INFORMATION

! WARNING

“THIS CONVERSION KIT SHALL BE INSTALLED BY A QUALIFIED SERVICE AGENCY IN ACCORDANCE WITH THE MANUFACTURER’S INSTRUCTIONS AND ALL APPLICABLE CODES AND REQUIREMENTS OF THE AUTHORITY HAVING JURISDICTION. IF THE INFORMATION IN THESE INSTRUCTIONS IS NOT FOLLOWED EXACTLY, A FIRE, EXPLOSION OR PRODUCTION OF CARBON MONOXIDE MAY RESULT CAUSING PROPERTY DAMAGE, PERSONAL INJURY OR LOSS OF LIFE. THE QUALIFIED SERVICE AGENCY IS RESPONSIBLE FOR THE PROPER INSTALLATION OF THIS KIT. THE INSTALLATION IS NOT PROPER AND COMPLETE UNTIL THE OPERATION OF THE CONVERTED APPLIANCE IS CHECKED AS SPECIFIED IN THE MANUFACTURER’S INSTRUCTIONS SUPPLIED WITH THE KIT.”



DANGER PELIGRO

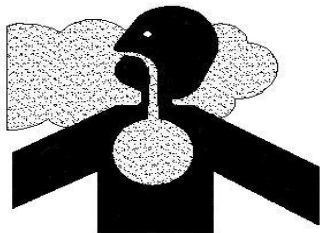

CARBON MONOXIDE POISONING HAZARD

Special Warning for Installation of Furnaces or Air Handling Units in Enclosed Areas such as Garages, Utility Rooms or Parking Areas

Carbon monoxide producing devices (such as an automobile, space heater, gas water heater, etc.) should not be operated in enclosed areas such as unventilated garages, utility rooms or parking areas because of the danger of carbon monoxide (CO) poisoning resulting from the exhaust emissions. If a furnace or air handler is installed in an enclosed area such as a garage, utility room or parking area and a carbon monoxide producing device is operated therein, there must be adequate, direct outside ventilation.

This ventilation is necessary to avoid the danger of CO poisoning which can occur if a carbon monoxide producing device continues to operate in the enclosed area. Carbon monoxide emissions can be (re)circulated throughout the structure if the furnace or air handler is operating in any mode.

CO can cause serious illness including permanent brain damage or death.

B10259-216



WARNING

TO AVOID PERSONAL INJURY, PROPERTY DAMAGE OR DEATH, DUE TO LEAKING GAS, CONTACT YOUR PROPANE SUPPLIER ABOUT INSTALLING A GAS DETECTING WARNING DEVICE. IRON OXIDE (RUST) CAN REDUCE THE LEVEL OF ODORANT IN PROPANE GAS. A GAS DETECTING DEVICE IS THE ONLY RELIABLE METHOD TO DETECT A PROPANE GAS LEAK.



CAUTION

TO AVOID THE RISK OF PROPERTY DAMAGE, PERSONAL INJURY OR FIRE, SHUT OFF GAS SUPPLY FIRST, THEN DISCONNECT THE ELECTRICAL SUPPLY BEFORE PROCEEDING WITH CONVERSION.

BEFORE BEGINNING CONVERSION:

VALVE IDENTIFICATION

Before beginning conversion, the type valve you have must be identified. Compare the gas valve presently on the equipment to the drawing below to identify the correct valve you are working with. Page numbers for the instructions for that valve are below each drawing.

White-Rodgers 36G22 and 36J22

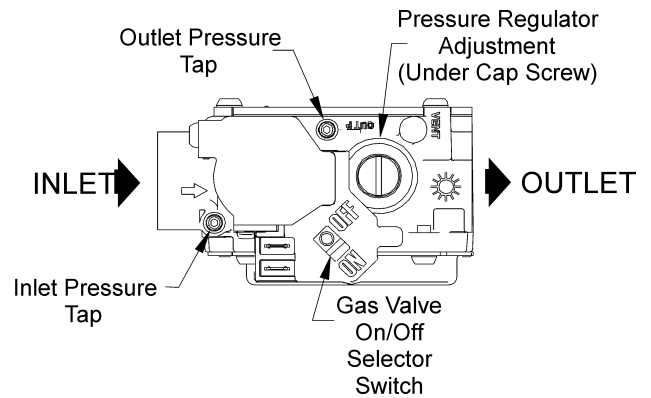

Instructions for these valves start on page 3.

Honeywell VR8215

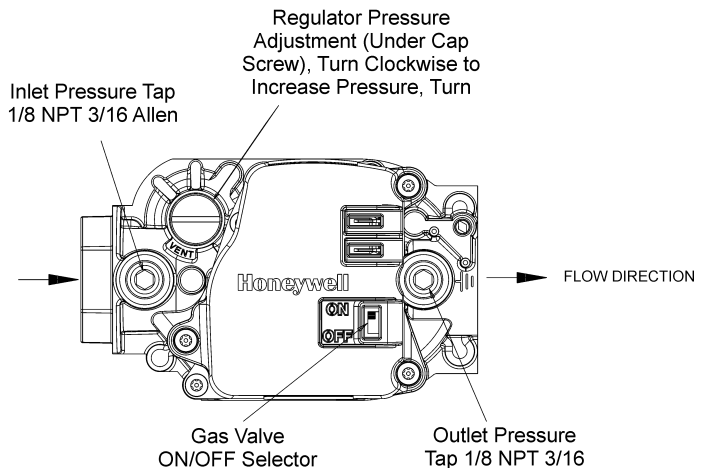

Instructions for this valve start on page 5.

WHITE-RODGERS 36G22 AND 36J22 CONVERSION INSTRUCTIONS

CAUTION

TO PREVENT UNSATISFACTORY FURNACE OPERATION, THE PROPER GAS CONVERSION KIT MUST BE USED FOR THE GAS VALVE. USE THE WHITE-RODGERS SPRING KIT ONLY WITH THE WHITE-RODGERS GAS VALVES.

NOTE: For low NOx models, see page 6 for NOx screens.

1. Turn off gas supply to the furnace.
2. Turn off the electrical power to the furnace.
3. Remove the furnace control access panel.
4. Separate the gas supply union and remove associated downstream piping.

NOTE: Always use a backup wrench when removing or replacing piping to avoid any undue strains or rotation of controls.

5. Remove the wires from the gas valve.
6. Remove the 4 sheet metal screws that fasten the manifold/gas valve assembly to the burner box.
7. Visually inspect orifices for damage and drill size (marked on face with 1.25mm) before installation. Using the 7/16" wrench, remove all existing natural gas orifices and replace with the appropriate 1.25mm L.P. gas orifices contained in this kit. Tighten the orifices to prevent gas leaks, but do not overtighten. Retain the natural gas orifices for future reconversion.
8. Install water manometer using Valve Pressure Check Kit P/N 0151K00000S included with this kit. Using the included 3/32" hex wrench, rotate outlet pressure tap screw one revolution counterclockwise. Attach the included 5/16" hose to the inlet and outlet pressure boss of the valve. Hose should overlap boss 3/8". Connect 5/16" side of included connector to the hose on the outlet boss. Connect 1/4" side of the connector to the manometer hose. The manometer must have a scale range of at least 0" to 20" of water column.

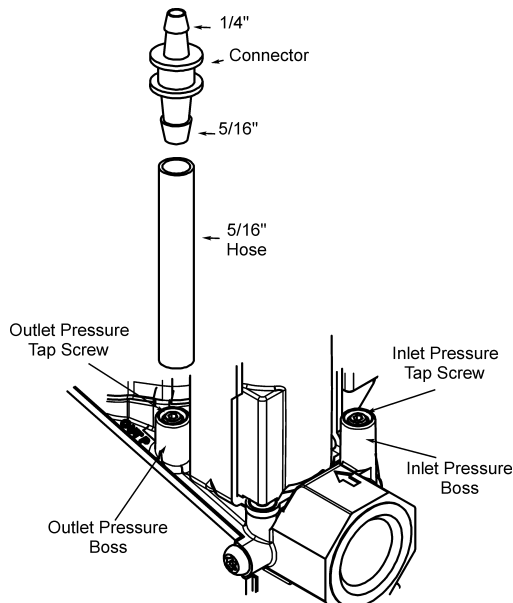

9. Using a flat blade screwdriver, remove the regulator cover screw.
10. Using a flat blade screwdriver, remove plastic regulator adjustment screw located beneath the cover screw.
11. Remove the natural gas regulator spring from the regulator sleeve.
12. Insert the kit (P/N B1880007, WR F92-0999) provided L.P. regulator spring into the regulator sleeve.
13. Replace the regulator adjustment screw.
14. Reinstall the manifold/gas valve assembly into the appliance. Rewire the gas valve.
15. Apply a liberal amount of pipe joint compound or pipe thread tape to the threads and reassemble the piping previously removed. **NOTE:** the pipe joint compound or pipe thread tape must be resistant to L.P. gas.
16. Turn on the gas supply and check for leaks.

WARNING

TO AVOID THE POSSIBILITY OF EXPLOSION OR FIRE, NEVER USE A MATCH OR OPEN FLAME TO TEST FOR LEAKS.

17. Turn on the electrical supply.
18. Adjust the room thermostat to allow for constant operation.
19. **If you have the correct manifold pressure and the burners do not light, there may be air trapped in the lines. Follow these instructions:**
To check for air trapped in the supply line: Verify line pressure is in the correct range. If manifold pressure is indicated during the ignition trial, the valve is opening and air may be in the line.
Units with hot surface ignitors: The valve will not open until the ignitor is at the proper temperature (glowing brightly).
Units with spark ignition: The valve will open as soon as the spark starts. If no manifold pressure is indicated during the trial for ignition, please return to step 13 to ensure the correct spring was used and to ensure the regulator adjustment is near the bottom of the adjustment range.
20. If gas inlet pressure falls outside the range of 11" and 13" W.C. after the unit has been in operation for 15 minutes, adjust the gas supply pressure (not manifold pressure), check piping size, etc., and/or consult with local utility.
NOTE: Any other gas-fired equipment should be ON before any adjustments are made.
21. Check manifold pressure. For propane gas, the manifold pressure must be between 9.7" and 10.3" W.C.

22. Turn adjustment screw out (counterclockwise) to decrease pressure, turn in (clockwise) to increase pressure. Only small variations in gas flow should be made by means of the pressure regulator adjustment. In no case should the final manifold pressure vary more than plus or minus 0.3" water column from the specified nominal pressure. Any major changes in flow should be made by changing the size of the burner orifices. The measured input rate to the furnace must not exceed the rating specified on the unit rating plate.
23. Reset all other appliances so they function normally.
24. Turn off gas and electrical supply to the furnace, remove the manometer hose from the pressure tap bosses, and tighten the inlet and outlet pressure tap screws using the 3/32" Allen wrench (clockwise 7 in-lb minimum).
25. If regulator adjustment screw (removed in step 11) is white, the gasket supplied with the kit must be installed on the regulator cover screw. The gasket is not required if the regulator adjustment screw is black.
26. Replace the regulator cover screw on the regulator sleeve.
27. Attach the kit provided WARNING label to the gas valve where it can be readily seen. Also attach the small round L.P. label to the top of the regulator cover screw.
28. Turn on the gas and electrical supply, energize the appliance and recheck for leaks.
29. Observe at least 3 ignition cycles to assure quick and smooth ignition and burner operation.
30. Reinstall the access panels.

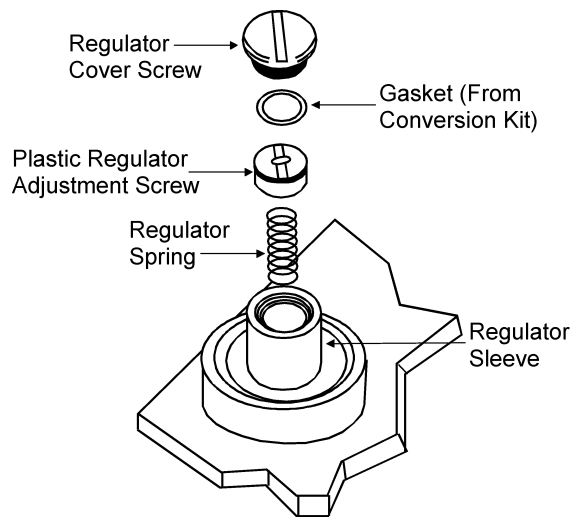

36G22 and 36J22 Model



CAUTION

TO AVOID THE RISK OF PROPERTY DAMAGE, PERSONAL INJURY OR FIRE, SHUT OFF GAS SUPPLY FIRST, THEN DISCONNECT THE ELECTRICAL SUPPLY BEFORE PROCEEDING WITH CONVERSION.

NOTE: Conversion instructions for the Honeywell VR8215 gas valve begin on the following page.

HONEYWELL VR8215

CONVERSION INSTRUCTIONS

CAUTION

TO PREVENT UNSATISFACTORY FURNACE OPERATION, THE PROPER GAS CONVERSION KIT MUST BE USED FOR THE GAS VALVE. USE THE HONEYWELL SPRING KIT ONLY WITH THE HONEYWELL GAS VALVE.

NOTE: For low NOx models, see page 6 for NOx screens.

1. Turn off gas supply to the furnace.
2. Turn off the electrical power to the furnace.
3. Remove the furnace control access panel.
4. Separate the gas supply union and remove associated downstream piping.

NOTE: Always use a backup wrench when removing or replacing piping to avoid any undue strains or rotation of controls.

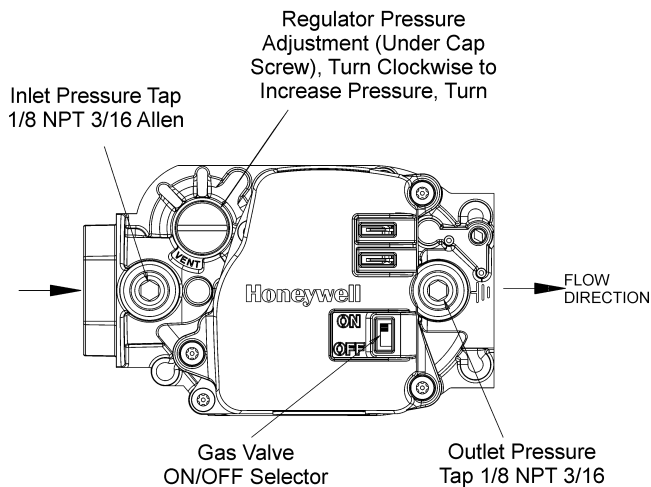

Honeywell VR8215

5. Remove the wires from the gas valve.
6. Remove the 4 sheet metal screws that fasten the manifold/gas valve assembly to the burner box.
7. Visually inspect orifices for damage and drill size (marked on face with 1.25mm) before installation. Using the 7/16" wrench, remove all existing natural gas orifices and replace with the appropriate 1.25mm L.P. gas orifices contained in this kit. Tighten the orifices to prevent gas leaks, but do not overtighten. Retain the natural gas orifices for future reconversion.
8. Reinstall the manifold/gas valve assembly into the appliance. Rewire the gas valve.
9. Remove both the inlet and outlet plugs on the gas valve, using the 3/16" Allen wrench. Install the fittings which

accompany the manometers into the 1/8" taped holes of the gas valve. Connect the manometers to the barbed fittings.

10. Using a flat blade screwdriver, remove the regulator cover screw.
11. Using a flat blade screwdriver, remove plastic regulator adjustment screw located beneath the cover screw.
12. Remove the natural gas regulator spring from the regulator sleeve.
13. Insert the kit (P/N 0163M00078, Honeywell P/N 396221) provided L.P. regulator spring into the regulator sleeve.
14. Replace the natural gas regulator adjustment screw with the L.P. regulator adjustment screw included in the kit.

NOTE: The LP regulator should be adjusted near the bottom of the adjustment range. DO NOT OVER-TIGHTEN.
15. Apply a liberal amount of pipe joint compound or pipe thread tape to the threads and reassemble the piping previously removed.

NOTE: the pipe joint compound or pipe thread tape must be resistant to L.P. gas.
16. Turn on the gas supply and check for leaks.

WARNING

TO AVOID THE POSSIBILITY OF EXPLOSION OR FIRE, NEVER USE A MATCH OR OPEN FLAME TO TEST FOR LEAKS.

17. Turn on the electrical supply.
18. Adjust the room thermostat to allow for constant operation.
19. **To check for air trapped in the supply line:** Verify line pressure is in the correct range. If manifold pressure is indicated during the ignition trial, the valve is opening and air may be in the line.

Units with hot surface ignitors: The valve will not open until the ignitor is at the proper temperature (glowing brightly).

Units with spark ignition: The valve will open as soon as the spark starts. If no manifold pressure is indicated during the trial for ignition, please return to step 13 to ensure the correct spring was used and to ensure the regulator adjustment is near the bottom of the adjustment range.
20. If gas inlet pressure falls outside the range of 11" and 13" W.C. after the unit has been in operation for 15 minutes, adjust the gas supply pressure (not manifold pressure), check piping size, etc., and/or consult with local utility.

NOTE: Any other gas-fired equipment should be ON before any adjustments are made.
21. Check manifold pressure. For propane gas, the manifold pressure must be between 9.7" and 10.3" W.C.

22. Turn adjustment screw out (counterclockwise) to decrease pressure, turn in (clockwise) to increase pressure. Only small variations in gas flow should be made by means of the pressure regulator adjustment. In no case should the final manifold pressure vary more than plus or minus 0.3" water column from the specified nominal pressure. Any major changes in flow should be made by changing the size of the burner orifices. The measured input rate to the furnace must not exceed the rating specified on the unit rating plate.
23. Reset all other appliances so they function normally.
24. Turn off the gas and electrical supply to the appliance, remove the pressure taps at the gas valve, reinstall the plugs using pipe joint compound or tape.

NON-CONDENSING FURNACES AND PACKAGE GAS-ELECTRIC

1. Remove the screws securing the burner box to the partition panel. Separate burner box from unit.
2. Remove the screw(s) securing the NOx screen retention plate and remove the plate.
3. Remove and discard NOx screens.
4. Reinstall the NOx screen retention plate and burner box.

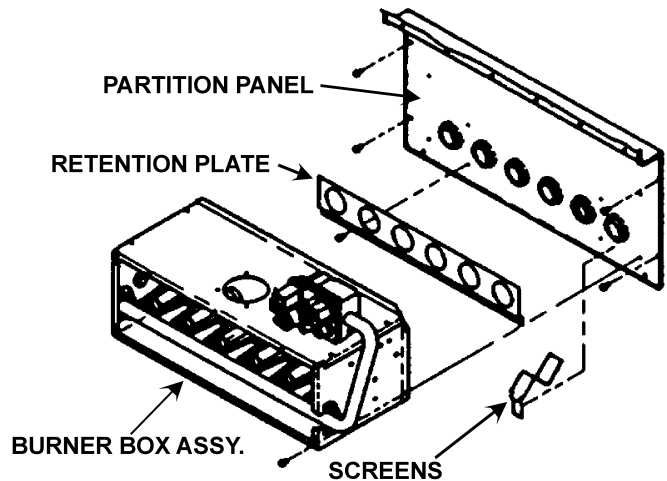

Typical NOx Screen Removal

 WARNING
<p>TO AVOID THE POSSIBILITY OF EXPLOSION OR FIRE, NEVER USE A MATCH OR OPEN FLAME TO TEST FOR LEAKS.</p>

25. Replace the regulator cover screw on the regulator sleeve.
26. Attach the kit provided ATTENTION label to the gas valve where it can be readily seen.
27. Turn on the gas and electrical supply, energize the appliance and recheck for leaks.
28. Observe at least 3 ignition cycles to assure quick and smooth ignition and burner operation.
29. Reinstall the access panels.

NOx SCREEN REMOVAL

 WARNING
<p>REMOVE ALL METAL SCREENS FROM THE HEAT EXCHANGER TUBES WHEN USING PROPANE GAS. FAILURE TO DO SO MAY CAUSE PROPERTY DAMAGE, PERSONAL INJURY OR DEATH AND <u>WILL</u> VOID WARRANTY COVERAGE.</p>

NOTE: To prevent premature heat exchanger failure, follow the instructions in the NON-CONDENSING FURNACES AND PACAKGE GAS-ELECTRIC section to remove all metal screen inserts from the entrance of heat exchanger tubes during propane conversions. Not all models will have metal screen inserts.

THIS PAGE LEFT INTENTIONALLY BLANK

NOTE: SPECIFICATIONS AND PERFORMANCE DATA LISTED HEREIN ARE SUBJECT TO CHANGE WITHOUT NOTICE

Quality Makes the Difference!

All of our systems are designed and manufactured with the same high quality standards regardless of size or efficiency. We have designed these units to significantly reduce the most frequent causes of product failure. They are simple to service and forgiving to operate. We use quality materials and components. Finally, every unit is run tested before it leaves the factory. That's why we know. . . **There's No Better Quality.**

Visit our website at www.daikincomfort.com, www.goodmanmfg.com or www.amana-hac.com for information on:

- Products
- Warranties
- Customer Services
- Parts
- Contractor Programs and Training
- Financing Options

5151 San Felipe, Suite 500, Houston, TX 77056

© 2014 Goodman Manufacturing Company, L.P.

Amana is a trademark of Maytag Corporation and is used under license. All rights reserved.