

INSTALLATION INSTRUCTIONS FOR *MVM96 & *CVM96 MODULATING GAS FURNACE

(Type FSP CATEGORY IV Direct or Non Direct Vent Air Furnace)

Installer: Affix all manuals adjacent to the unit.

These furnaces comply with requirements embodied in the American National Standard / National Standard of Canada ANSI Z21.47- CSA-2.3 Gas Fired Central Furnaces.



RECOGNIZE THIS SYMBOL AS A SAFETY PRECAUTION.

ATTENTION INSTALLING PERSONNEL

As a professional installer you have an obligation to know the product better than the customer. This includes all safety precautions and related items.

Prior to actual installation, thoroughly familiarize yourself with this Instruction Manual. Pay special attention to all safety warnings. Often during installation or repair it is possible to place yourself in a position which is more hazardous than when the unit is in operation.

Remember, it is your responsibility to install the product safely and to know it well enough to be able to instruct a customer in its safe use.

Safety is a matter of common sense...a matter of thinking before acting. Most dealers have a list of specific good safety practices...follow them.

The precautions listed in this Installation Manual are intended as supplemental to existing practices. However, if there is a direct conflict between existing practices and the content of this manual, the precautions listed here take precedence.

*NOTE: Please contact your distributor
or our website for the applicable
Specification Sheet referred to in this manual.

5151 San Felipe Suite 500
Houston, TX 77056

www.goodmanmfg.com • www.amana-hac.com



TABLE OF CONTENTS

SHIPPING INSPECTION	6
ELECTROSTATIC DISCHARGE (ESD) PRECAUTIONS	6
TO THE INSTALLER	6
IMPORTANT NOTE TO THE OWNER REGARDING PRODUCT WARRANTY	6
PRODUCT DESCRIPTION	7
FEATURES	7
PRODUCT APPLICATION	7
LOCATION REQUIREMENTS & CONSIDERATIONS	8
CLEARANCES AND ACCESSIBILITY	9
EXISTING FURNACE REMOVAL	9
THERMOSTAT LOCATION	10
COMBUSTION & VENTILATION AIR REQUIREMENTS	10
INSTALLATION POSITIONS	10
HORIZONTAL APPLICATIONS & CONSIDERATIONS	10
FURNACE SUSPENSION	11
DRAIN TRAP AND LINES	11
LEVELING	11
ALTERNATE VENT/FLUE AND COMBUSTION AIR CONNECTIONS	11
ALTERNATE ELECTRICAL AND GAS LINE CONNECTIONS	12
DRAIN PAN	12
FREEZE PROTECTION	12
PROPANE GAS/HIGH ALTITUDE INSTALLATIONS	12
VENT/FLUE PIPE & COMBUSTION AIR PIPE	12
DUAL CERTIFICATION: NON-DIRECT/DIRECT VENT	13
MATERIALS AND JOINING METHODS	13
PROPER VENT/FLUE AND COMBUSTION AIR PIPING PRACTICES	13
TERMINATION LOCATIONS	13
CANADIAN VENTING REQUIREMENTS	14
STANDARD FURNACE CONNECTIONS	14
ALTERNATE FURNACE CONNECTIONS	15
NON-DIRECT VENT (SINGLE PIPE) PIPING	17
DIRECT VENT (DUAL PIPE) PIPING	18
VENT/INTAKE TERMINATIONS FOR INSTALLATION OF MULTIPLE DIRECT VENT FURNACES	20
CONCENTRIC VENT TERMINATION	20
SIDE WALL VENT KIT	20
CONDENSATE DRAIN LINES & DRAIN TRAP	20
STANDARD RIGHT OR LEFT SIDE DRAIN HOSE CONNECTIONS	21
UPRIGHT INSTALLATIONS-TRAP ON RIGHT SIDE	21
UPRIGHT INSTALLATIONS-TRAP ON LEFT SIDE	23
HORIZONTAL INSTALLATIONS	24
ELECTRICAL CONNECTIONS	26
WIRING HARNESS	26
115 VOLT LINE CONNECTIONS	26
JUNCTION BOX RELOCATION	26
24 VOLT THERMOSTAT WIRING	27
SINGLE-STAGE HEATING THERMOSTAT APPLICATION	28
24 VOLT DEHUMIDISTAT WIRING	28
FOSSIL FUEL APPLICATIONS	28
115 VOLT LINE CONNECTION OF ACCESSORIES (HUMIDIFIER AND ELECTRONIC AIR CLEANER)	28
24 VOLT HUMIDIFIER	29

GAS SUPPLY AND PIPING	29
HIGH ALTITUDE DERATE	29
PROPANE GAS CONVERSION	29
GAS PIPING CONNECTIONS	30
PROPANE GAS TANKS AND PIPING	32
CIRCULATING AIR & FILTERS	33
DUCT WORK - AIR FLOW	33
CHECKING DUCT STATIC	33
BOTTOM RETURN AIR OPENING [UPFLOW MODELS]	34
FILTERS - READ THIS SECTION BEFORE INSTALLING THE RETURN AIR DUCT WORK	34
UPRIGHT INSTALLATIONS	35
HORIZONTAL INSTALLATIONS	35
STARTUP PROCEDURE & ADJUSTMENT	35
HEATING OPERATION WITH CTK01AA THERMOSTAT (COMMUNICATING)	36
HEATING OPERATION WITH CTK02AA THERMOSTAT (MODULATING COMMUNICATING)	37
HEAT ANTICIPATOR SETTING	37
DRAIN TRAP PRIMING	37
FURNACE OPERATION	37
GAS SUPPLY PRESSURE MEASUREMENT	37
GAS MANIFOLD PRESSURE MEASUREMENT	38
GAS INPUT RATE MEASUREMENT (NATURAL GAS ONLY)	39
TEMPERATURE RISE	39
CIRCULATOR BLOWER SPEEDS	40
BLOWER HEAT OFF DELAY TIMINGS	42
COMFORTNET™ SYSTEM	42
OVERVIEW	42
AIRFLOW CONSIDERATION	42
DIP SWITCHES	44
FOSSIL FUEL APPLICATIONS	45
CTK0*AA WIRING	45
COMFORTNET™ SYSTEM ADVANCED FEATURES	45
FURNACE ADVANCED FEATURES MENU	46
NETWORK TROUBLESHOOTING	47
SYSTEM TROUBLESHOOTING	47
FAULT RECALL SEQUENCE	47
FAULT CLEAR SEQUENCE:	48
NORMAL SEQUENCE OF OPERATION	48
POWER UP	48
HEATING MODE	48
COOLING MODE	49
FAN ONLY MODE	49
OPERATIONAL CHECKS	49
SAFETY CIRCUIT DESCRIPTION	49
INTEGRATED FURNACE CONTROL (IFC)	49
PRIMARY LIMIT	49
AUXILIARY LIMIT	49
ROLLOUT LIMIT	49
PRESSURE SWITCHES	50
FLAME SENSOR	50

TROUBLESHOOTING 50

ELECTROSTATIC DISCHARGE (ESD) PRECAUTIONS 50

DIAGNOSTIC CHART 50

RESETTING FROM LOCKOUT 50

MAINTENANCE 50

ANNUAL INSPECTION 51

FILTERS 51

BURNERS 51

INDUCED DRAFT AND CIRCULATOR BLOWERS 51

CONDENSATE TRAP AND DRAIN SYSTEM (QUALIFIED SERVICER ONLY) 51

FLAME SENSOR (QUALIFIED SERVICER ONLY) 51

BEFORE LEAVING AN INSTALLATION 52

REPAIR AND REPLACEMENT PARTS 52

TROUBLESHOOTING CODES 53

STATUS CODES 58

WIRING DIAGRAM 59

 **WARNING**

GOODMAN WILL NOT BE RESPONSIBLE FOR ANY INJURY OR PROPERTY DAMAGE ARISING FROM IMPROPER SERVICE OR SERVICE PROCEDURES. IF YOU INSTALL OR PERFORM SERVICE ON THIS UNIT, YOU ASSUME RESPONSIBILITY FOR ANY PERSONAL INJURY OR PROPERTY DAMAGE WHICH MAY RESULT. MANY JURISDICTIONS REQUIRE A LICENSE TO INSTALL OR SERVICE HEATING AND AIR CONDITIONING EQUIPMENT.

Adhere to the following warnings and cautions when installing, adjusting, altering, servicing, or operating the furnace. To ensure proper installation and operation, thoroughly read this manual for specifics pertaining to the installation and application of this product.

 **WARNING**

TO PREVENT PERSONAL INJURY OR DEATH DUE TO IMPROPER INSTALLATION, ADJUSTMENT, ALTERATION, SERVICE OR MAINTENANCE, REFER TO THIS MANUAL. FOR ADDITIONAL ASSISTANCE OR INFORMATION, CONSULT A QUALIFIED INSTALLER, SERVICER AGENCY OR THE GAS SUPPLIER.

 **WARNING**

IF THE INFORMATION IN THESE INSTRUCTIONS IS NOT FOLLOWED EXACTLY, A FIRE OR EXPLOSION MAY RESULT CAUSING PROPERTY DAMAGE, PERSONAL INJURY OR LOSS OF LIFE.

— DO NOT STORE OR USE GASOLINE OR OTHER FLAMMABLE VAPORS AND LIQUIDS IN THE VICINITY OF THIS OR ANY OTHER APPLIANCE.

— **WHAT TO DO IF YOU SMELL GAS:**

- DO NOT TRY TO LIGHT ANY APPLIANCE.
- DO NOT TOUCH ANY ELECTRICAL SWITCH; DO NOT USE ANY PHONE IN YOUR BUILDING.
- IMMEDIATELY CALL YOUR GAS SUPPLIER FROM A NEIGHBOR'S PHONE. FOLLOW THE GAS SUPPLIER'S INSTRUCTIONS.
- IF YOU CANNOT REACH YOUR GAS SUPPLIER, CALL THE FIRE DEPARTMENT.

— INSTALLATION AND SERVICE MUST BE PERFORMED BY A QUALIFIED INSTALLER, SERVICE AGENCY OR THE GAS SUPPLIER.

 **WARNING**

THIS PRODUCT CONTAINS OR PRODUCES A CHEMICAL OR CHEMICALS WHICH MAY CAUSE SERIOUS ILLNESS OR DEATH AND WHICH ARE KNOWN TO THE STATE OF CALIFORNIA TO CAUSE CANCER, BIRTH DEFECTS OR OTHER REPRODUCTIVE HARM.

 **WARNING**

HEATING UNIT SHOULD NOT BE UTILIZED WITHOUT REASONABLE, ROUTINE, INSPECTION, MAINTENANCE AND SUPERVISION. IF THE BUILDING IN WHICH ANY SUCH DEVICE IS LOCATED WILL BE VACANT, CARE SHOULD BE TAKEN THAT SUCH DEVICE IS ROUTINELY INSPECTED, MAINTAINED AND MONITORED. IN THE EVENT THAT THE BUILDING MAYBE EXPOSED TO FREEZING TEMPERATURES AND WILL BE VACANT, ALL WATER-BEARING PIPES SHOULD BE DRAINED, THE BUILDING SHOULD BE PROPERLY WINTERIZED, AND THE WATER SOURCE CLOSED. IN THE EVENT THAT THE BUILDING MAY BE EXPOSED TO FREEZING TEMPERATURES AND WILL BE VACANT, ANY HYDRONIC COIL UNITS SHOULD BE DRAINED AS WELL AND, IN SUCH CASE, ALTERNATIVE HEAT SOURCES SHOULD BE UTILIZED.

 **WARNING**

TO PREVENT POSSIBLE PROPERTY DAMAGE, PERSONAL INJURY OR DEATH DUE TO ELECTRICAL SHOCK, THE FURNACE MUST BE LOCATED TO PROTECT THE ELECTRICAL COMPONENTS FROM WATER.



DANGER
PELIGRO



CARBON MONOXIDE POISONING HAZARD

Special Warning for Installation of Furnace or Air Handling Units in Enclosed Areas such as Garages, Utility Rooms or Parking Areas

Carbon monoxide producing devices (such as an automobile, space heater, gas water heater, etc.) should not be operated in enclosed areas such as unventilated garages, utility rooms or parking areas because of the danger of carbon monoxide (CO) poisoning resulting from the exhaust emissions. If a furnace or air handler is installed in an enclosed area such as a garage, utility room or parking area and a carbon monoxide producing device is operated therein, there must be adequate, direct outside ventilation.

This ventilation is necessary to avoid the danger of CO poisoning which can occur if a carbon monoxide producing device continues to operate in the enclosed area. Carbon monoxide emissions can be (re)circulated throughout the structure if the furnace or air handler is operating in any mode.

CO can cause serious illness including permanent brain damage or death.

B10259-216

 **WARNING**

SHOULD OVERHEATING OCCUR OR THE GAS SUPPLY FAIL TO SHUT OFF, TURN OFF THE MANUAL GAS SHUTOFF VALVE EXTERNAL TO THE FURNACE BEFORE TURNING OFF THE ELECTRICAL SUPPLY.

 **WARNING**

POSSIBLE PROPERTY DAMAGE, PERSONAL INJURY OR DEATH DUE TO FIRE, EXPLOSION, SMOKE, SOOT, CONDENSATION, ELECTRICAL SHOCK OR CARBON MONOXIDE MAY RESULT FROM IMPROPER INSTALLATION, REPAIR OPERATION, OR MAINTENANCE OF THIS PRODUCT.

SHIPPING INSPECTION

All units are securely packed in shipping containers tested according to International Safe Transit Association specifications. The carton must be checked upon arrival for external damage. If damage is found, a request for inspection by carrier's agent must be made in writing immediately.

The furnace must be carefully inspected on arrival for damage and bolts or screws which may have come loose in transit. In the event of damage the consignee should:

1. Make a notation on delivery receipt of any visible damage to shipment or container.
2. Notify carrier promptly and request an inspection.
3. With concealed damage, carrier must be notified as soon as possible - preferably within five days.
4. File the claim with the following support documents within a nine month statute of limitations.
 - Original or certified copy of the Bill of Lading, or indemnity bond.
 - Original paid freight bill or indemnity in lieu thereof.
 - Original or certified copy of the invoice, showing trade and other discounts or reductions.
 - Copy of the inspection report issued by carrier's representative at the time damage is reported to carrier.

The carrier is responsible for making prompt inspection of damage and for a thorough investigation of each claim. The distributor or manufacturer will not accept claims from dealers for transportation damage.

ELECTROSTATIC DISCHARGE (ESD) PRECAUTIONS

NOTE: Discharge body's static electricity before touching unit. An electrostatic discharge can adversely affect electrical components.

Use the following precautions during furnace installation and servicing to protect the integrated control module from damage. By putting the furnace, the control, and the person at the same electrostatic potential, these steps will help avoid exposing the integrated control module to electrostatic discharge. This procedure is applicable to both installed and non-installed (ungrounded) furnaces.

1. Disconnect all power to the furnace. Do not touch the integrated control module or any wire connected to the control prior to discharging your body's electrostatic charge to ground.
2. Firmly touch a clean, unpainted, metal surface of the furnaces near the control. Any tools held in a person's hand during grounding will be discharged.
3. Service integrated control module or connecting wiring following the discharge process in step 2. Use caution not to recharge your body with static electricity; (i.e., do not move or shuffle your feet, do not touch ungrounded objects, etc.). If you come in contact with an ungrounded object, repeat step 2 before touching control or wires.

4. Discharge your body to ground before removing a new control from its container. Follow steps 1 through 3 if installing the control on a furnace. Return any old or new controls to their containers before touching any ungrounded object.

TO THE INSTALLER

Before installing this unit, please read this manual thoroughly to familiarize yourself with specific items which must be adhered to, including but not limited to: unit maximum external static pressure, gas pressures, BTU input rating, proper electrical connections, circulating air temperature rise, minimum or maximum CFM, and motor speed connections.

IMPORTANT NOTE TO THE OWNER REGARDING PRODUCT WARRANTY

Your warranty certificate is supplied as a separate document with the unit installed by your contractor. Read the limited warranty certificate carefully to determine what is and is not covered and keep the warranty certificate in a safe place. If you are unable to locate the warranty certificate please contact your installing contractor or contact customer service (877-254-4729) to obtain a copy.

To receive the Lifetime Heat Exchanger Limited Warranty (good for as long as you own your home) and the 10-year Parts Limited Warranty, online registration must be completed within 60 days of installation. Online registration is not required in California or Quebec. Complete warranty details are available from your local dealer or at www.goodmanmfg.com or at www.amana-hac.com.

To register your Goodman brand unit, go to www.goodmanmfg.com. Click on the word "Warranty" located on the left side of the home page. Next, click on the word "Product Registration" located on the left side of the Warranty page and complete the forms in the manner indicated on the Product Registration page.

To register your Amana® brand unit, go to www.amana-hac.com. Click on the word "Warranty" located on the top right of the home page. Next, click on the word "Product Registration" located on the left side of the Warranty page and complete the forms in the manner indicated on the Product Registration page.

Product limited warranty certificates for models currently in production can be viewed at www.goodmanmfg.com or www.amana-hac.com. If your model is not currently in production or does not appear on the website, please contact your installing contractor or contact customer service at (877-254-4729) to obtain a copy of your warranty certificate.

Each product overview page contains a Product Warranty link; by clicking on it you will be able to view the limited warranty coverage for that specific product. To view warranty registration information, click on the Product Warranty text on the left navigation panel on the home page of each website. The Online Product Registration pages are located in this same section.



WARNING

TO PREVENT PROPERTY DAMAGE, PERSONAL INJURY OR DEATH DUE TO FIRE, DO NOT INSTALL THIS FURNACE IN A MOBILE HOME, TRAILER, OR RECREATIONAL VEHICLE.

PRODUCT DESCRIPTION

FEATURES

This furnace is a part of the ComfortNet™ family of products. The CTK0*AA thermostat kit allows this furnace to be installed as part of a digitally communicating system. The ComfortNet system provides automatic airflow configuration, enhanced setup features, and enhanced diagnostics. It also reduces the number of thermostat wires to a maximum of four. It may be also installed as part of a non-communicating system using a standard 24 VAC thermostat.

This product may be installed with the ComfortNet thermostat and a non-ComfortNet compatible single stage air conditioning unit. However, this reduces the benefits of the ComfortNet system as the enhancements will only apply to the furnace.

The modulating furnace operation is based off of negative pressure created by the the draft inducer. The Integrated Furnace Control (IFC) receives commands from the room thermostat. The IFC then controls the RPM of the (3 phase) inducer by varying the frequency and voltage to the inducer. This is known as variable frequency drive (VFD). The inducer, pressure switches, and gas valve are linked by pneumatic tubing. The gas valve modulates based on this negative pressure.

PRODUCT APPLICATION

This furnace is primarily designed for residential home-heating applications. It is NOT designed or certified for use in mobile homes, trailers or recreational vehicles. Neither is it designed or certified for outdoor applications. The furnace **must** be installed indoors (i.e., attic space, crawl space, or garage area provided the garage area is enclosed with an operating door).

This furnace can be used in the following non-industrial commercial applications:

**Schools, Office buildings, Churches, Retail stores,
Nursing homes, Hotels/motels, Common or office areas**

In such applications, the furnace must be installed with the following stipulations:

- It must be installed per the installation instructions provided and per local and national codes.
- It must be installed indoors in a building constructed on site.
- It must be part of a ducted system and not used in a free air delivery application.
- It must not be used as a “make-up” air unit.
- It must be installed with two-pipe systems for combustion air, especially if VOC’s or other contaminants are present in the conditioned space.
- All other warranty exclusions and restrictions apply This furnace is an ETL dual-certified appliance and is appropriate for use with natural or propane gas (**NOTE:** If using propane, a propane conversion kit is required).

Dual certification means that the combustion air inlet pipe is optional and the furnace can be vented as a:

Non-direct vent (single pipe) central forced air furnace in which combustion air is taken from the installation area or from air ducted from the outside or,

Direct vent (dual pipe) central forced air furnace in which all combustion air supplied directly to the furnace burners through a special air intake system outlined in these instructions.

This furnace may be used as a construction site heater **ONLY** if all of the following conditions are met:

- The vent system is permanently installed per these installation instructions.
- A room thermostat is used to control the furnace. Fixed jumpers that provide continuous heating CANNOT be used and can cause long term equipment damage.
- Return air ducts are provided and sealed to the furnace.
- A return air temperature range between 60°F (16°C) and 80°F (27°C) is maintained.
- Air filters are installed in the system and maintained during construction replaced as appropriate during construction, and upon completion of construction.
- The input rate and temperature rise are set per the furnace rating plate.
- 100% outside air is provided for combustion air requirements during construction. Temporary ducting can be used.

NOTE: Do not connect the temporary duct directly to the furnace. The duct must be sized for adequate combustion and ventilation in accordance with the latest edition of the National Fuel Gas Code NFPA 54/ANSI Z223.1 or CAN/CSA B149.1 Installation Codes.

- The furnace heat exchanger, components, duct system, air filters and evaporator coils are thoroughly cleaned following final construction clean up.

- All furnace operating conditions (including ignition, input rate, temperature rise and venting) are verified according to these installation instructions.

NOTE: The Commonwealth of Massachusetts requires that the following additional requirements must also be met:

- Gas furnaces must be installed by a licensed plumber or gas fitter.
- A T-handle gas cock must be used.
- If the unit is to be installed in an attic, the passageway to and the service area around the unit must have flooring.

To ensure proper furnace operation, install, operate and maintain the furnace in accordance with these installation and operation instructions, all local building codes and ordinances. In their absence, follow the latest edition of the National Fuel Gas Code (NFPA 54/ANSI Z223.1), and/or CAN/CSA B149 Installation Codes, local plumbing or waste water codes, and other applicable codes.

A copy of the National Fuel Gas Code (NFPA 54/ANSI Z223.1) can be obtained from any of the following:

American National Standards Institute

1430 Broadway
New York, NY 10018

National Fire Protection Association

1 Batterymarch Park
Quincy, MA 02269

CSA International

8501 East Pleasant Valley
Cleveland, OH 44131

The rated heating capacity of the furnace should be greater than or equal to the total heat loss of the area to be heated. The total heat loss should be calculated by an approved method or in accordance with "ASHRAE Guide" or "Manual J-Load Calculations" published by the Air Conditioning Contractors of America.

A copy of the CAN/CSA B149 Installation Codes can also be obtained from:

CSA International

178 Rexdale Boulevard
Etobicoke, Ontario, Canada M9W 1R3

LOCATION REQUIREMENTS & CONSIDERATIONS

Follow the instructions listed below and the guidelines provided in the *Combustion and Ventilation Air Requirements* section when selecting a furnace location.

 **WARNING**

TO PREVENT POSSIBLE EQUIPMENT DAMAGE, PROPERTY DAMAGE, PERSONAL INJURY OR DEATH, THE FOLLOWING BULLET POINTS MUST BE OBSERVED WHEN INSTALLING THIS UNIT.

 **WARNING**

POSSIBLE PROPERTY DAMAGE, PERSONAL INJURY OR DEATH DUE TO FIRE, EXPLOSION, SMOKE, SOOT, CONDENSATION, ELECTRICAL SHOCK OR CARBON MONOXIDE MAY RESULT FROM IMPROPER INSTALLATION, REPAIR OPERATION, OR MAINTENANCE OF THIS PRODUCT.

- Centrally locate the furnace with respect to the proposed or existing air distribution system.
- Ensure the temperature of the return air entering the furnace is between 55°F and 100°F when the furnace is heating.
- Provide provisions for venting combustion products outdoors through a proper venting system. Special consideration should be given to vent/flue pipe routing and combustion air intake pipe when applicable. Refer to *Vent/Flue Pipe and Combustion Air Pipe - Termination Locations* for appropriate termination locations and to determine if the piping system from furnace to termination can be accomplished within the guidelines given. **NOTE:** The length of flue and/or combustion air piping can be a limiting factor in the location of the furnace.
- Locate the furnace so condensate flows downwards to the drain. Do not locate the furnace or its condensate drainage system in any area subject to below freezing temperatures without proper freeze protection. Refer to *Condensate Drain Lines and Trap* for further details.
- Ensure adequate combustion air is available for the furnace. Improper or insufficient combustion air can expose building occupants to gas combustion products that could include carbon monoxide. Refer to *Combustion and Ventilation Air Requirements*.
- Set the furnace on a level floor to enable proper condensate drainage. If the floor becomes wet or damp at times, place the furnace above the floor on a concrete base sized approximately 1-1/2" larger than the base of the furnace. Refer to the *Horizontal Applications and Considerations* for leveling of horizontal furnaces.
- Ensure upflow or horizontal furnaces are not installed directly on carpeting, or any other combustible material. The only combustible material allowed is wood.
- A special accessory subbase must be used for upright counterflow unit installations over any combustible material (including wood). Refer to subbase instructions for installation details. (**NOTE:** A subbase will not be required if an air conditioning coil is located beneath the furnace between the supply air opening and the combustible floor.
- Exposure to contaminated combustion air will result in safety and performance-related problems. Do not install the furnace where the combustion air is exposed to the following substances:
 - permanent wave solutions
 - chlorinated waxes or cleaners
 - chlorine-based swimming pool chemicals
 - water softening chemicals

deicing salts or chemicals
 carbon tetrachloride
 halogen type refrigerants
 cleaning solutions (such as perchloroethylene)
 printing inks
 paint removers
 varnishes
 hydrochloric acid
 cements and glues
 antistatic fabric softeners for clothes dryers
 and masonry acid washing materials

- Seal off a *non-direct vent* furnace if it is installed near an area frequently contaminated by any of the above substances. This protects the *non-direct vent* furnace from airborne contaminants. To ensure that the enclosed *non-direct vent* furnace has an adequate supply of combustion air, vent from a nearby uncontaminated room or from outdoors. Refer to the *Combustion and Ventilation Air Requirements* for details.
- If the furnace is used in connection with a cooling coil unit, install the furnace upstream or in parallel with the cooling coil unit. Premature heat exchanger failure will result if the cooling unit is placed ahead of the furnace.
- If the furnace is installed in a residential garage, position the furnace so that the burners and ignition source are located not less than 18 inches (457 mm) above the floor. Protect the furnace from physical damage by vehicles.
- If the furnace is installed horizontally, ensure the access doors are not on the “up/top” or “down/bottom” side of the furnace.
- Do not connect this furnace to a chimney flue that serves a separate appliance designed to burn solid fuel.
- On Counterflow Installations, the air conditioning coil must be downstream on the supply (positive) side of the furnace heat exchanger.
- *Counterflow Installation over a noncombustible floor.* Before setting the furnace over the plenum opening, ensure the surface around the opening is smooth and level. A tight seal should be made between the furnace base and floor by using a silicone rubber caulking compound or cement grout.
- *Counterflow Installation over a combustible floor.* If installation over a combustible floor becomes necessary, use an accessory subbase (see Specification Sheet applicable for your model for details.) A special accessory subbase must be used for upright counterflow unit installations over any combustible material including wood. Refer to subbase instructions for installation details. Follow the instructions with the subbase for proper installation. Do not install the furnace directly on carpeting, tile, or other combustible material other than wood flooring. (**NOTE:** The subbase will not be required if an air conditioning coil is installed between the supply air opening on the furnace and the floor.)

CLEARANCES AND ACCESSIBILITY

Installations must adhere to the clearances to combustibles to which this furnace has been design certified. The minimum clearance information for this furnace is provided on the unit's clearance label. These clearances must be permanently maintained. Clearances must also accommodate an installation's gas, electrical, and drain trap and drain line connections. If the alternate combustion air intake or vent/flue connections are used additional clearance must be provided to accommodate these connections. Refer to *Vent/Flue Pipe and Combustion Air Pipe* for details. **NOTE:** In addition to the required clearances to combustibles, a minimum of 24 inches service clearance must be available in front of the unit.

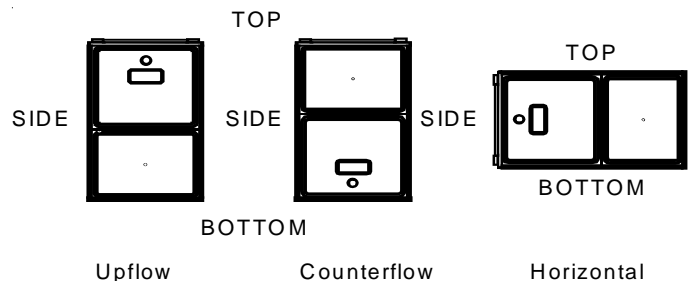

A furnace installed in a confined space (i.e., a closet or utility room) must have two ventilation openings with a total minimum free area of 0.25 square inches per 1,000 BTU/hr of furnace input rating. Refer to Specification Sheet applicable to your model for minimum clearances to combustibles. One of the ventilation openings must be within 12 inches of the top; the other opening must be within 12 inches of the bottom of the confined space. In a typical construction, the clearance between the door and door frame is usually adequate to satisfy this ventilation requirement.

EXISTING FURNACE REMOVAL

NOTE: When an existing furnace is removed from a venting system serving other appliances, the venting system may be too large to properly vent the remaining attached appliances.

The following vent testing procedure is reproduced from the **American National Standard/National Standard of Canada for Gas-Fired Central Furnaces ANSI Z21.4, CSA-2.3 latest edition Section 1.23.1.**

The following steps shall be followed with each appliance connected to the venting system placed in operation, while any other appliances connected to the venting system are not in operation:

1. Seal any unused openings in the venting system;
2. Inspect the venting system for proper size and horizontal pitch, as required by the National Fuel Gas Code, ANSI Z223.1 or the Natural Gas and Propane Installation Code, CSA B149.1-05 and these instructions. Determine that there is no blockage or restriction, leakage, corrosion and other deficiencies which could cause an unsafe condition.

3. As far as practical, close all building doors and windows and all doors between the space in which the appliance(s) connected to the venting system are located and other spaces of the building.
4. Close fireplace dampers.
5. Turn on clothes dryers and any appliance not connected to the venting system. Turn on any exhaust fans, such as range hoods and bathroom exhausts, so they shall operate at maximum speed. Do not operate a summer exhaust fan.
6. Follow the lighting instructions. Place the appliance being inspected in operation. Adjust thermostat so appliance shall operate continuously.
7. Test for spillage from draft hood appliances at the draft hood relief opening after 5 minutes of main burner operation. Use the flame of a match or candle.
8. If improper venting is observed during any of the above tests, the venting system must be corrected in accordance with the National Fuel Gas Code ANSI Z223.1/ NFPA 54 and/or National Gas and Propane Installation Code CSA B149.1-05.
9. After it has been determined that each appliance connected to the venting system properly vents when tested as outlined above, return doors, windows, exhaust fans, fireplace dampers and any other gas burning appliance to their previous conditions of use.

If resizing is required on any portion of the venting system, use the appropriate table in Appendix G in the latest edition of the National Fuel Gas Code ANSI Z223.1 and/or CSA B149.1-05 Installation Codes.

THERMOSTAT LOCATION

The thermostat should be placed approximately five feet from the floor on a vibration-free, inside wall in an area having good air circulation. Do not install the thermostat where it may be influenced by any of the following:

- Drafts, or dead spots behind doors, in corners, or under cabinets.
- Hot or cold air from registers.
- Radiant heat from the sun.
- Light fixtures or other appliances.
- Radiant heat from a fireplace.
- Concealed hot or cold water pipes, or chimneys.
- Unconditioned areas behind the thermostat, such as an outside wall.

Consult the instructions packaged with the thermostat for mounting instructions and further precautions.

COMBUSTION & VENTILATION AIR REQUIREMENTS

WARNING

TO AVOID PROPERTY DAMAGE, PERSONAL INJURY OR DEATH, SUFFICIENT FRESH AIR FOR PROPER COMBUSTION AND VENTILATION OF FLUE GASES MUST BE SUPPLIED. MOST HOMES REQUIRE OUTSIDE AIR BE SUPPLIED INTO THE FURNACE AREA.

Improved construction and additional insulation in buildings have reduced heat loss by reducing air infiltration and escape around doors and windows. These changes have helped in reducing heating/cooling costs but have created a problem supplying combustion and ventilation air for gas fired and other fuel burning appliances. Appliances that pull air out of the house (clothes dryers, exhaust fans, fireplaces, etc.) increase the problem by starving appliances for air.

House depressurization can cause back drafting or improper combustion of gas-fired appliances, thereby exposing building occupants to gas combustion products that could include carbon monoxide.

If this furnace is to be installed in the same space with other gas appliances, such as a water heater, ensure there is an adequate supply of combustion and ventilation air for the other appliances. Refer to the latest edition of the National Fuel Gas Code NFPA 54/ANSI Z223.1 or CAN/CSA B149 Installation Codes or applicable provisions of the local building codes for determining the combustion air requirements for the appliances.

Most homes will require outside air be supplied to the furnace area by means of ventilation grilles or ducts connecting directly to the outdoors or spaces open to the outdoors such as attics or crawl spaces.

INSTALLATION POSITIONS

This furnace may be installed in an upright position or horizontal on either the left or right side panel. Do not install this furnace on its back. For *upright upflow* furnaces, return air ductwork may be attached to the side panel(s) and/or basepan. For *horizontal upflow* furnaces, return air ductwork must be attached to the basepan. For both *upright or horizontal counterflow* furnaces, return ductwork must be attached to the basepan (top end of the blower compartment). **NOTE: Ductwork must never be attached to the back of the furnace.** Contact your distributor for proper airflow requirements and number of required ductwork connections. Refer to "Recommended Installation Positions" figure for appropriate installation positions, ductwork connections, and resulting airflow arrangements.

HORIZONTAL APPLICATIONS & CONSIDERATIONS

Horizontal applications, in particular, may dictate many of the installation's specifics such as airflow direction, ductwork connections, flue and combustion air pipe connections, etc. The basic application of this furnace as a horizontal furnace differs only slightly from an upright installation. When installing a furnace horizontally, additional consideration must be given to the following:

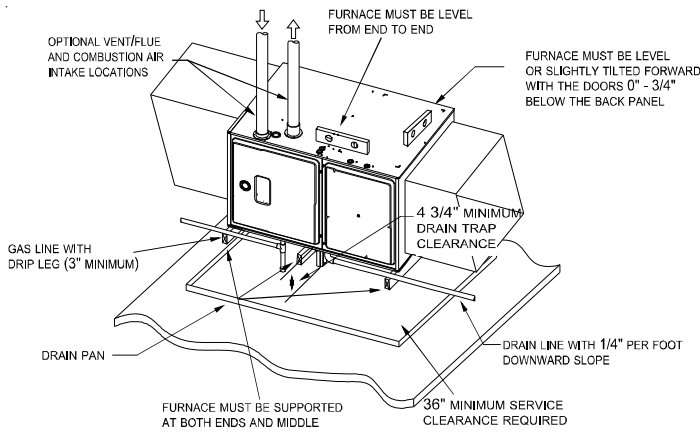

Horizontal Furnace

FURNACE SUSPENSION

If suspending the furnace from rafters or joists, use 3/8" threaded rod and 2"x2"x1/8" angle iron as shown in the following diagram. The length of rod will depend on the application and the clearances necessary.

If the furnace is installed in a crawl space it must be suspended from the floor joist or supported by a concrete pad. Never install the furnace on the ground or allow it to be exposed to water.

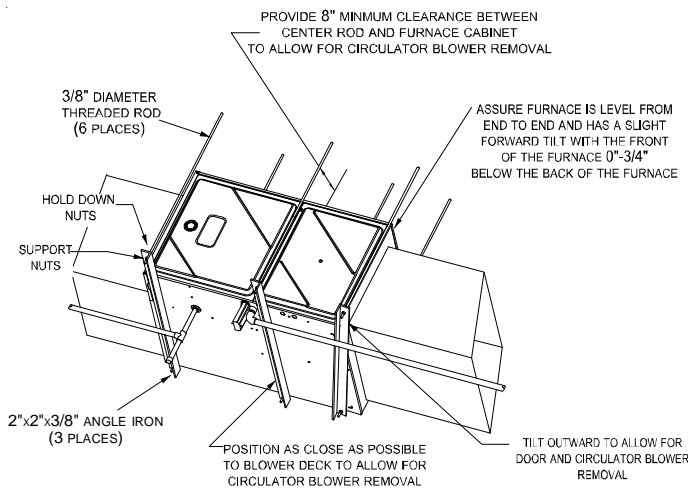

DRAIN TRAP AND LINES

In horizontal applications the condensate drain trap is secured to the furnace side panel, suspending it below the furnace. A minimum clearance of 4 3/4 inches below the furnace must be provided for the drain trap. Additionally, the appropriate downward piping slope must be maintained from the drain trap to the drain location. Refer to *Condensate Drain Trap and Lines* for further details. If the drain trap and drain line will be exposed to temperatures near or below freezing, adequate measures must be taken to prevent condensate from freezing.

LEVELING

Leveling ensures proper condensate drainage from the heat exchanger and induced draft blower. For proper flue pipe drainage, the furnace must be level lengthwise from end to end. The furnace should also be level from back to front or have a slight tilt with the access doors downhill (approximately 3/4 inches) from the back panel. The slight tilt allows the heat exchanger condensate, generated in the recuperator coil, to flow forward to the recuperator coil front cover.

ALTERNATE VENT/FLUE AND COMBUSTION AIR CONNECTIONS

In horizontal installations provisions for alternate flue and combustion air piping are available for upflow furnaces with left discharge and counterflow furnaces with right air discharge. This configuration allows the flue and combustion air piping to be run vertically through the side of the furnace. Refer to the "Recommended Installation Positions" figure for further detail. The standard piping connections may also be used in these positions. Refer to *Vent/Flue Pipe and Combustion Air Pipe* for details concerning the conversion to the alternate vent/flue and combustion air connections.

When using the horizontal alternate vent configuration, you must use the RF000142 vent drain kit. See following illustration.

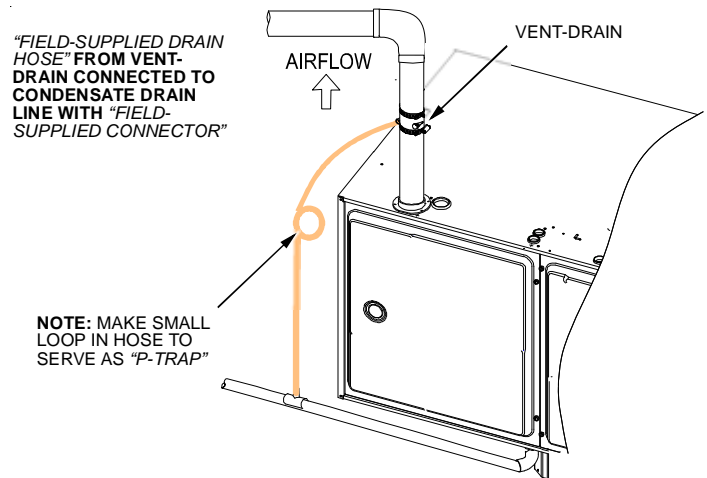

Alternate Vent/Flue Location

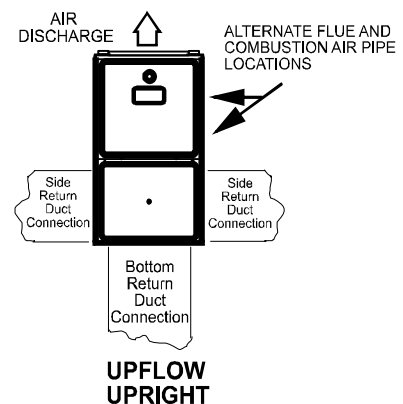

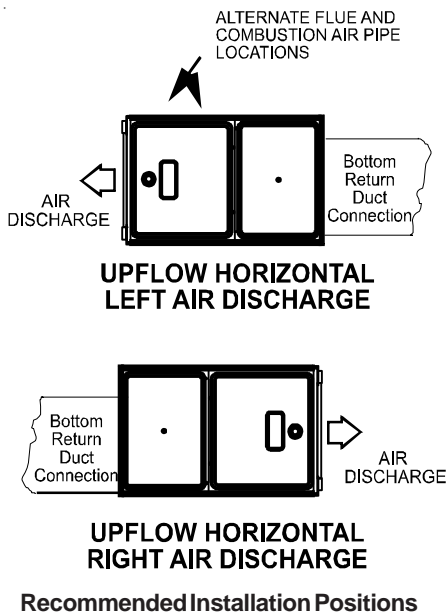

NOTE: Alternate “vertical” piping connections can not be used when an upflow furnace is installed with supply air discharging to the right, or when a counterflow furnace is installed with supply air discharging to the left. In either case, use the standard flue and combustion air piping connections.

ALTERNATE ELECTRICAL AND GAS LINE CONNECTIONS

This furnace has provisions allowing for electrical and gas line connections through either side panel. In horizontal applications the connections can be made either through the “top” or “bottom” of the furnace.

DRAIN PAN

A drain pan must be provided if the furnace is installed above a conditioned area. The drain pan must cover the entire area under the furnace (and air conditioning coil if applicable).

FREEZE PROTECTION

Refer to *Horizontal Applications and Conditions - Drain Trap and Lines*.

PROPANE GAS/HIGH ALTITUDE INSTALLATIONS

WARNING

POSSIBLE PROPERTY DAMAGE, PERSONAL INJURY OR DEATH MAY OCCUR IF THE CORRECT CONVERSION KITS ARE NOT INSTALLED. THE APPROPRIATE KITS MUST BE APPLIED TO ENSURE SAFE AND PROPER FURNACE OPERATION. ALL CONVERSIONS MUST BE PERFORMED BY A QUALIFIED INSTALLER OR SERVICE AGENCY.

This furnace is shipped from the factory configured for natural gas up to 10,000 ft. altitude. Propane conversions require the proper LP kit to compensate for the energy content difference between natural and propane gas.

LP kits include a manifold assembly, including an LP gas valve, orifices and LP burners.

Gas	Altitude	Kit	Orifice	Manifold Pressure		Pressure Switch Change
				High Stage	Low Stage	
Natural	0-7000	None	#45 ¹	3.5" w.c.	1" w.c.	None
Propane		LPKMOD****	1.25MM ²	10.0" w.c.	2.6" w.c.	None

NOTE: In Canada, gas furnaces are only certified to 4500 feet.

¹ Except 115,000 BTU: #43

² Except 115,000 BTU: #55

Furnace Model	LP Kit
A/GMVM960603BX	LPKMOD060UF
A/GMVM960805CX	LPKMOD080UF
A/GMVM961005DX	LPKMOD100UF
A/GMVM961155DX	LPKMOD115UF
A/GCVM960604CX	LPKMOD060CF
A/GCVM960805DX	LPKMOD080CF
GCM961005DX	LPKMOD100CF

The indicated kits must be used to insure safe and proper furnace operation. All conversions must be performed by a qualified installer, or service agency.

VENT/FLUE PIPE & COMBUSTION AIR PIPE

WARNING

FAILURE TO FOLLOW THESE INSTRUCTIONS CAN RESULT IN BODILY INJURY OR DEATH. CAREFULLY READ AND FOLLOW ALL INSTRUCTIONS GIVEN IN THIS SECTION.

WARNING

UPON COMPLETION OF THE FURNACE INSTALLATION, CAREFULLY INSPECT THE ENTIRE FLUE SYSTEM BOTH INSIDE AND OUTSIDE OF THE FURNACE TO ASSURE IT IS PROPERLY SEALED. LEAKS IN THE FLUE SYSTEM CAN RESULT IN SERIOUS PERSONAL INJURY OR DEATH DUE TO EXPOSURE TO FLUE PRODUCTS, INCLUDING CARBON MONOXIDE.

A condensing gas furnace achieves its high level of efficiency by extracting almost all of the heat from the products of combustion and cooling them to the point where condensation takes place. Because of the relatively low flue gas temperature and water condensation requirements, PVC pipe is used as venting material.

This furnace must not be connected to Type B, BW, or L vent or vent connector, and must not be vented into any portion of a factory built or masonry chimney except when used as a pathway for PVC as described later in this section. Never common vent this appliance with another appliance or use a vent which is used by a solid fuel appliance. Do not use commercially available “no hub connectors” other than those shipped with this product.

It is the responsibility of the installer to follow the manufacturers' recommendations and to verify that all vent/flue piping and connectors are compatible with furnace flue products. Additionally, it is the responsibility of the installer to ensure that all piping and connections possess adequate structural integrity and support to prevent flue pipe separation, shifting, or sagging during furnace operation.

DUAL CERTIFICATION: NON-DIRECT/DIRECT VENT

This furnace is dual certified and may be installed as a non-direct vent (single pipe) or direct vent (dual pipe) appliance. A *non-direct vent* installation requires only a vent/flue pipe, while a *direct vent* installation requires both a vent/flue pipe and a combustion air intake pipe. Refer to the appropriate section for details concerning piping size, length, number of elbows, furnace connections, and terminations.



WARNING

TO AVOID BODILY INJURY, FIRE OR EXPLOSION, SOLVENT CEMENTS MUST BE KEPT AWAY FROM ALL IGNITION SOURCES (I.E., SPARKS, OPEN FLAMES, AND EXCESSIVE HEAT) AS THEY ARE COMBUSTIBLE LIQUIDS. AVOID BREATHING CEMENT VAPORS OR CONTACT WITH SKIN AND/OR EYES.

Two- or three-inch nominal diameter PVC Schedule 40 pipe meeting ASTM D1785, PVC primer meeting ASTM F656, and PVC solvent cement meeting ASTM D2564 specifications must be used. Fittings must be DWV type fittings meeting ASTM D2665 and ASTM D3311. Carefully follow the pipe manufacturer's instructions for cutting, cleaning, and solvent cementing of PVC.

The use of Schedule 40 PVC or ABS cellular core (Foam Core) plastic pipe is also acceptable as a flue/vent and intake pipe material. PVC primer meeting ASTM F656 and PVC solvent cement meeting ASTM D2564 specifications must be used. Fittings must be DWV type fittings meeting ASTM D2665 and ASTM D3311. Carefully follow the manufacturer's instructions for cutting, cleaning and solvent cementing of PVC.

MATERIALS AND JOINING METHODS

As an alternative to PVC pipe, primer, solvent cement, and fittings, ABS materials which are in compliance with the following specifications may be used. Two-or-three-inch ABS Schedule 40 pipe must meet ASTM D1527 and, if used in Canada, must be CSA listed. Solvent cement for ABS to ABS joints must meet ASTM D2235 and, if used in Canada, must be CSA listed. The solvent cement for the PVC to ABS transition joint must meet ASTM D3138. Fittings must be DWV type fittings meeting ASTM D2661 and ASTM D3311 and, if used in Canada, must be CSA listed. Carefully follow the manufacturers' instructions for cutting, cleaning, and solvent cementing PVC and/or ABS.

All 90° elbows must be medium radius (1/4 bend DWV) or long radius (Long sweep 1/4 bend DWV) types conforming to ASTM D3311. A medium radius (1/4 bend DWV) elbow measures 3 1/16" minimum from the plane of one opening to the centerline of the other opening for 2" diameter pipe, and 4 9/16" minimum for 3" pipe.

PROPER VENT/FLUE AND COMBUSTION AIR PIPING PRACTICES

Adhere to these instructions to ensure safe and proper furnace performance. The length, diameter, and number of elbows of the vent/flue pipe and combustion air pipe (when applicable) affects the performance of the furnace and must be carefully sized. All piping must be installed in accordance with local codes and these instructions.

Piping must be adequately secured and supported to prohibit sagging, joint separation, and/or detachment from the furnace. Horizontal runs of vent/flue piping must be supported every three to five feet and must maintain a 1/4 inch per foot downward slope, back towards the furnace, to properly return condensate to the furnace's drain system. Allowances should be made for minor expansion and contraction due to temperature variations. For this reason, particular care must be taken to secure piping when a long run is followed by a short offset of less than 40 inches.

Precautions should be taken to prevent condensate from freezing inside the vent/flue pipe and/or at the vent/flue pipe termination. All vent/flue piping exposed to temperatures below 35°F for extended periods of time must be insulated with 1/2" thick closed cell foam. Also all vent/flue piping exposed outdoors in excess of the terminations shown in this manual (or in unheated areas) must be insulated with 1/2" thick closed cell foam. Inspect piping for leaks prior to installing insulation.

TERMINATION LOCATIONS

NOTE: Refer to *Location Requirements and Considerations* for combustion air contaminant restrictions.

The following bullets and diagram describe the restrictions concerning the appropriate location of vent/flue pipe and combustion air intake pipe (when applicable) terminations. Refer to *Non-Direct Vent (Single Pipe) Piping* and *Direct Vent (Dual Pipe) Piping* located in this section for specific details on termination construction.

- All terminations (flue and/or intake) must be located at least 12 inches above ground level or the anticipated snow level.
- Vent terminations (non-direct and direct vent) must terminate at least 3 feet above any forced air inlet located within 10 feet.
NOTE: This provision does not apply to the combustion air intake termination of a direct vent application.
- The vent termination of a *non-direct vent* application must terminate at least 4 feet below, 4 feet horizontally from, or 1 foot above any door, window, or gravity air inlet into any building.
- The vent termination of a *direct vent* application must terminate at least 12 inches from any opening through which flue gases may enter a building (door, window, or gravity air inlet).
- The vent termination of vent pipe run vertically through a roof must terminate at least 12 inches above the roof line (or the anticipated snow level) and be at least 12 inches from any vertical wall (including any anticipated snow build up).

- A vent termination shall not terminate over public walkways or over an area where condensate or vapor could create a nuisance or hazard or could be detrimental to the operation of regulators, relief valves, or other equipment.
- The combustion air intake termination of a direct vent application should not terminate in an area which is frequently dusty or dirty.

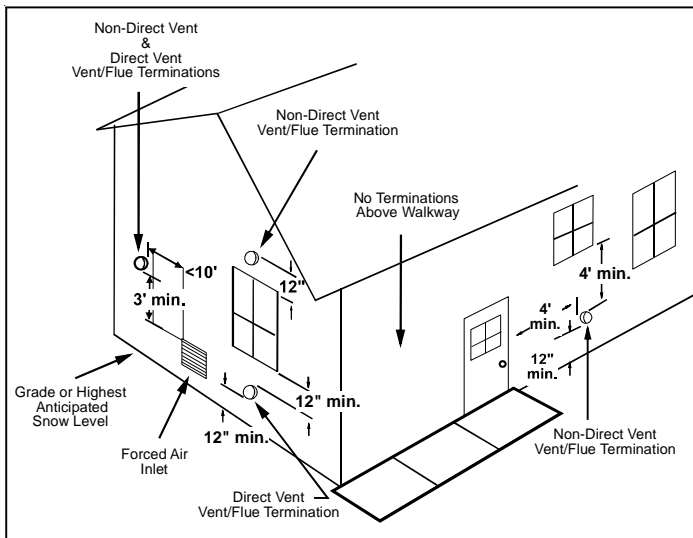

Vent Termination Clearances

NOTE: In Canada, the Canadian Fuel Gas Code takes precedence over the preceding termination restrictions.

CANADIAN VENTING REQUIREMENTS

In Canada, venting must conform to the requirements of the current CAN/CSA-B149.1-05 Installation Code. Use only CSA-listed, ULC-S636 compliant two- or three-inch diameter PVC or ABS pipe, solvent cement, and fittings throughout. The certified piping should be clearly marked with the ULC Std "S636" on the pipe and fittings. Carefully follow the pipe manufacturers' instructions for cutting, cleaning, and solvent cementing PVC and/or ABS.

The vent can be run through an existing unused chimney provided the space between the vent pipe and the chimney is insulated and closed with a weather-tight, corrosion-resistant flashing.

STANDARD FURNACE CONNECTIONS

It is the responsibility of the installer to ensure that the piping connections to the furnace are secure, airtight, and adequately supported.

As shipped, attachment "couplings" for vent/flue and combustion air intake pipe connections are provided on the furnace's top cover (upflow) or basepan (counterflow). To use the standard connections, field supplied vent/flue pipe and combustion air intake pipe (when applicable) should be secured directly to the furnace at these locations.

VENT/FLUE PIPE

Vent/flue pipe can be secured to the vent/flue coupling using the rubber coupling and worm gear hose clamps provided with this furnace (see "Standard Connections" figure). The rubber coupling allows separation of the vent/flue pipe from the furnace during servicing. Combustion Air and Vent piping should be routed in a manner to avoid contact with refrigerant lines, metering devices, condensate drain lines, etc. If necessary, clearances may be increased by utilizing two 45 deg. Long-Sweep Elbows and creating an "S" joint to provide additional space at connection locations. This joint can be rotated on the fitting to establish maximum clearance between refrigerant lines, metering devices, and condensate drain lines, etc. This joint is the equivalent of one 90 deg. elbow when considering elbow count.

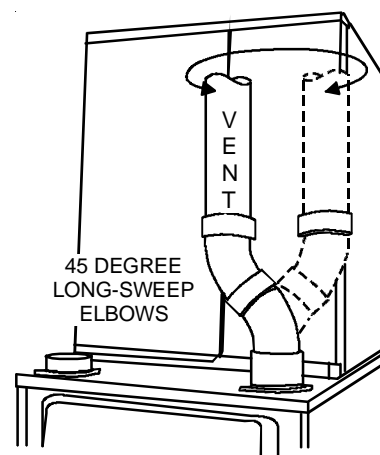

Increased Clearance Configuration

NOTE: Do not use other commercially available "no hub connectors" due to possible material conflicts. The vent/flue pipe can also be secured using a PVC or ABS elbow or coupling using the appropriate glue (see *Materials and Joining Methods*).

NOTE: For *non-direct vent* installations, a minimum of one 90° elbow should be installed on the combustion air intake coupling to guard against inadvertent blockage.

COMBUSTION AIR PIPE

DIRECT VENT INSTALLATIONS

On *upflow* units secure the combustion air intake pipe directly to the air intake coupling. On *counterflow* units secure the combustion air intake pipe to the air intake coupling using the rubber coupling and worm gear hose clamps provided with the unit. The counterflow rubber coupling allows service removal of air intake piping internal to the furnace blower compartment. **NOTE:** Because of probable material conflicts, do not use other commercially available "no hub connectors". The combustion air intake pipe can also be secured directly to the counterflow unit air intake pipe coupling.

NON-DIRECT VENT INSTALLATIONS

A minimum of one 90° elbow should be installed on the combustion air intake “coupling” to guard against inadvertent blockage.

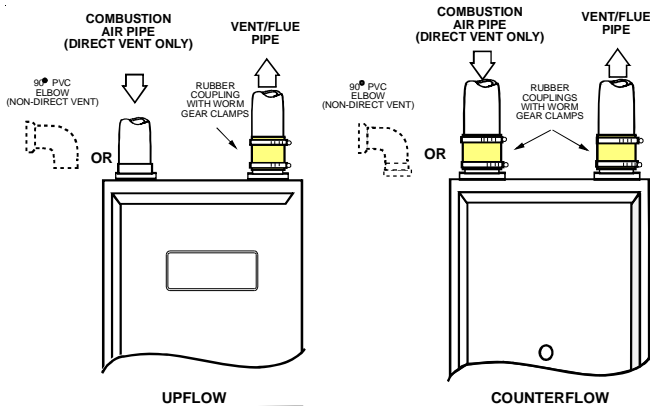

Standard Connections

ALTERNATE FURNACE CONNECTIONS

If the standard locations are undesirable for a specific installation, alternate side panel locations are available for both combustion air inlet and vent/flue pipe connections. These locations may be of particular benefit to upright upflow installations requiring additional access to an **A** coil, or to upright counterflow installations requiring additional access to a filter or electronic air cleaner, or to horizontal installations desiring vent/flue (and combustion air intake) piping run vertically from the side of the cabinet.

NOTE: Standard and alternate locations can be combined (i.e., an installation may use the standard combustion air intake location but use the alternate vent/flue location or vice versa), if needed.



WARNING

EDGES OF SHEET METAL HOLES MAY BE SHARP. USE GLOVES AS A PRECAUTION WHEN REMOVING HOLE PLUGS.

ALTERNATE VENT/FLUE LOCATION

The alternate vent/flue location is the large hole directly in line with the induced draft blower outlet. To use the alternate vent/flue location refer to the following steps and the “Alternate Vent/Flue Location” figure.

NOTE: Counterflow instructions follow the upflow instructions.

1. Remove and save the four screws securing the vent/flue coupling to the furnace top panel.

Counterflow units.

Remove and save the four screws securing the vent/flue coupling to the furnace basepan. Also remove the three screws securing the furnace’s internal vent/flue piping to the blower deck.

2. *Upflow and Counterflow units.*

Loosen the worm gear hose clamps on the rubber elbow and detach it from both the induced draft blower and the vent/flue pipe.

3. *Upflow and Counterflow units.*

Remove the vent/flue pipe from the furnace.

4. Cut the vent/flue pipe 3.75 inches from the flanged end of the pipe (see “Vent/Flue Pipe Cuts” figure). The section of pipe attached to the coupling will reach through the side panel to the induced draft blower. Discard remaining pipe and elbows.

Counterflow units.

Cut the vent/flue pipe 3.75 inches from the blower deck coupling (see “Vent/Flue Pipe Cuts” figure). Save vent/flue pipe attached to blower deck coupling for use in the alternate location. Discard remaining pipe and elbows.

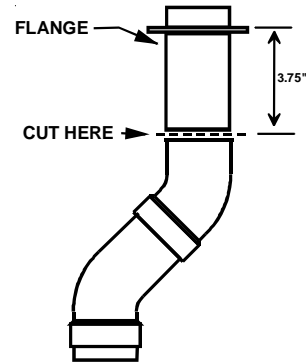

Vent/Flue Pipe Cuts

5. Remove plastic plug from alternate vent/flue location. Relocate and install plug in standard vent/flue location (top cover).

Counterflow units.

Remove plastic plug from alternate vent/flue location. Relocate and install plug in standard vent/flue location (basepan). Plug remaining hole in blower deck with plastic plug included in the drain kit bag.

6. *Upflow and Counterflow units.*

Insert cut section of vent/flue pipe and coupling into alternate vent/flue location. Using a rubber coupling and worm gear hose clamps from the drain kit bag, attach the vent/flue pipe and coupling to the induced draft blower. Secure the coupling to the cabinet using the screws removed in step 1 or with field-supplied 3/8” #8 self drilling screws.



WARNING

THE RUBBER ELBOW IS NOT DESIGNED TO SUPPORT A LOAD. WHEN THE RUBBER ELBOW IS MOUNTED EXTERNALLY TO THE FURNACE CABINET, EXTREME CARE MUST BE TAKEN TO ADEQUATELY SUPPORT FIELD-SUPPLIED VENT/FLUE PIPING, AS DAMAGE CAN RESULT IN LEAKS CAUSING BODILY INJURY OR DEATH DUE TO EXPOSURE TO FLUE GASES, INCLUDING CARBON MONOXIDE

7. *Upflow and Counterflow units.*

For **upright installations**, externally mount the rubber elbow to the vent/flue coupling using a worm gear hose clamp. Secure field supplied vent/flue piping to the rubber elbow using a worm gear hose clamp. **NOTE:** Use of the alternate vent/flue location for upright installations, requires the drain trap be installed on the same side of the unit as the flue pipe.

8. *Upflow and Counterflow* units.

For **horizontal installations**, externally secure the field-supplied vent/flue pipe directly to the vent/flue coupling using a PVC or ABS coupling or elbow.

ALTERNATE COMBUSTION AIR INTAKE LOCATION

The alternate combustion air intake location consists of a large, unobstructed hole (alternate vent connection is aligned with the Induced Draft Blower). To use the alternate combustion air intake location, refer to the following steps, and the “Alternate Combustion Air Intake Location” figure.

1. Remove and save the four screws securing the combustion air intake coupling to the basepan. Remove an additional three screws securing the furnace’s internal combustion air intake pipe to the blower deck.
2. Remove the combustion air intake pipe from the furnace and cut the pipe at the basepan coupling. Save the basepan coupling and gasket from the blower deck coupling for use in the alternate location. Discard the remaining pipe.

3. Remove plastic plug from alternate combustion air intake location. Relocate and install plug in standard air intake location (basepan). Plug the remaining hole in the blower deck with the plastic plug included in the drain kit bag.
4. With the gasket facing the cabinet side panel, and the flange’s flat spot facing forward, secure the combustion air intake coupling to the cabinet using the screws removed in step 1 or with field-supplied 3/8” #8 self-drilling screws.



BE SURE NOT TO DAMAGE INTERNAL WIRING OR OTHER COMPONENTS WHEN REINSTALLING COUPLING AND SCREWS.

5. For **non-direct vent installations** installed *horizontally*, a minimum of one 90° elbow should be installed on the combustion air intake coupling to guard against inadvertent blockage. No elbow is required on the alternate combustion air intake of *upright* installations, however, a minimum clearance of 2 inches is required to assure proper air supply.

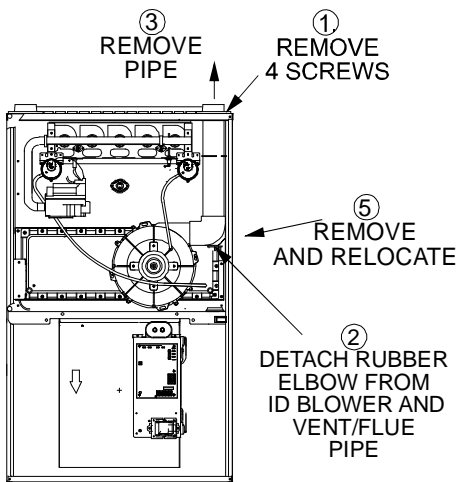

UPFLOW

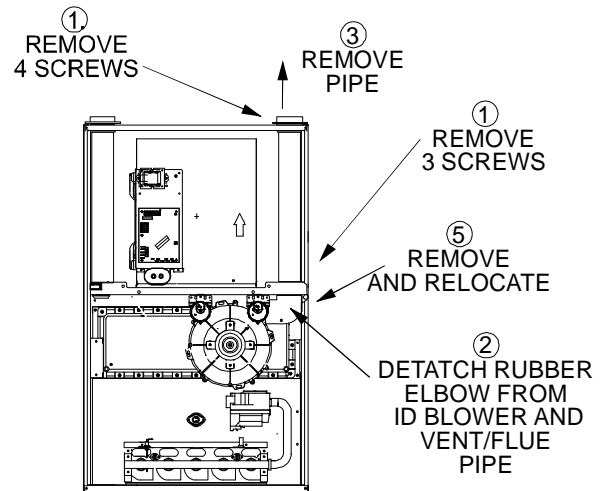

COUNTERFLOW

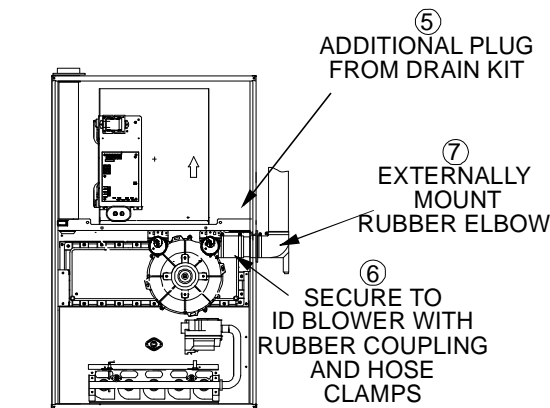

COUNTERFLOW/UPRIGHT
(UPFLOW SIMILAR)

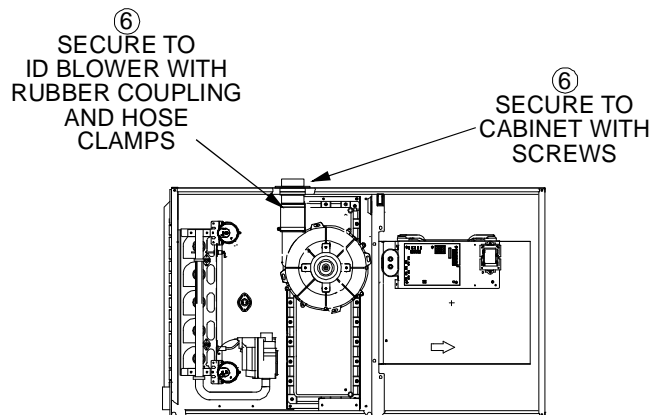

UPFLOW/HORIZONTAL
(COUNTERFLOW SIMILAR)

6. For **direct vent installations**, secure field-supplied combustion air intake pipe directly to the air intake coupling.

NOTE: A PVC coupling or elbow is required on counterflow units.

NON-DIRECT VENT (SINGLE PIPE) PIPING

Non-direct vent installations require only a vent/flue pipe. The vent pipe can be run horizontally with an exit through the side of the building or run vertically with an exit through the roof of the building. The vent can also be run through an existing *unused* chimney; however, it must extend a minimum of 12 inches above the top of the chimney. The space between the vent pipe and the chimney must be closed with a weather-tight, corrosion-resistant flashing. For details concerning connection of the vent/flue pipe to the furnace, refer to *Vent/Flue Pipe and Combustion Air - Standard Furnace Connections* or *Alternate Furnace Connections* for specific details. Refer to the following *Non-Direct Vent (Single Pipe) Piping - Vent/Flue Pipe Terminations* for specific details on termination construction.

Although *non-direct vent* installations do not require a combustion air intake pipe, a minimum of one 90° elbow should be attached to the furnace's combustion air intake *if*: an upright installation uses the standard intake location, or a horizontal installation uses the alternate air intake location. This elbow will guard against inadvertent blockage of the air intake.

VENT/FLUE PIPE LENGTHS AND DIAMETERS

Refer to the following table for applicable length, elbows, and pipe diameter for construction of the vent/flue pipe system of a non-direct vent installation. In addition to the vent/flue pipe, a single 90° elbow should be secured to the combustion air intake to prevent inadvertent blockage. The tee used in the vent/flue termination must be included when determining the number of elbows in the piping system.

UPFLOW Non-Direct Vent (Single Pipe) Maximum Allowable Length of Vent/Flue Pipe (ft) ⁽¹⁾⁽²⁾									
Unit Input	Pipe ⁽⁴⁾ (Inch)	Number of Elbows ⁽³⁾⁽⁵⁾							
		1	2	3	4	5	6	7	8
60,000	2 or 2 1/2	49	46	43	40	37	34	31	28
	3	71	68	65	62	59	56	53	50
80,000	3	71	68	65	62	59	56	53	50
100,000 115,000	3	49	46	43	40	37	34	31	28

*Maximum allowable limits listed are individual lengths for inlet & flue and NOT a combination.

COUNTERFLOW Non-Direct Vent (Single Pipe) Maximum Allowable Length of Vent/Flue Pipe (ft) ⁽¹⁾⁽²⁾									
Unit Input	Pipe ⁽⁴⁾ (Inch)	Number of Elbows ⁽³⁾⁽⁵⁾							
		1	2	3	4	5	6	7	8
60,000	2 or 2 1/2	61	58	55	52	49	46	43	40
	3	71	68	65	62	59	56	53	50
80,000	2 or 2 1/2	61	58	55	52	49	46	43	40
	3	71	68	65	62	59	56	53	50
100,000	3	71	68	65	62	59	56	53	50

*Maximum allowable limits listed are individual lengths for inlet & flue and NOT a combination.

- 1) One 90° elbow should be secured to the combustion air intake connection.
- 2) Minimum requirement for each vent pipe is five (5) feet in length and one elbow/tee.
- 3) Tee used in the vent/flue termination must be included when determining the number of elbows in the piping system.
- 4) 2-1/2" or 3" diameter pipe can be used in place of 2" diameter pipe.
- 5) Increased Clearance Configurations using (2) 45 deg. Long Sweep elbows should be considered equivalent to one 90 deg. elbow.

VENT/FLUE PIPE TERMINATIONS

NOTE: If either a 90 degree or 45 degree elbow is used for termination, it must be pointed downward.

The vent/flue pipe may terminate vertically, as through a roof, or horizontally, as through an outside wall.

Vertical vent/flue pipe terminations should be as shown in the following figure. Refer to *Vent/Flue Pipe and Combustion Air Pipe - Termination Locations* for details concerning location restrictions. The penetration of the vent through the roof must be sealed tight with proper flashing such as is used with a plastic plumbing vent.

Horizontal vent/flue pipe terminations should be as shown in the following figure. Refer to *Vent/Flue Pipe and Combustion Air Pipe - Termination Locations* for details concerning location restrictions. A 2 3/8" diameter wall penetration is required for 2" diameter pipe. A 3" diameter hole is required for a 2 1/2" pipe and a 3 1/2" diameter hole is required for 3" diameter pipe. To secure the pipe passing through the wall and prohibit damage to piping connections, a coupling should be installed on either side of the wall and solvent cemented to a length of pipe connecting the two couplings. The length of pipe should be the wall thickness plus the depth of the socket fittings to be installed on the inside and outside of the wall. The wall penetration should be sealed with silicone caulking material.

In a basement installation, the vent/flue pipe can be run between joist spaces. If the vent pipe must go below a joist and then up into the last joist space to penetrate the header, two 45° elbows should be used to reach the header rather than two 90° elbows.

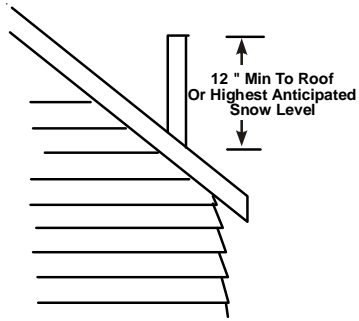

Vertical Termination (Single Pipe)

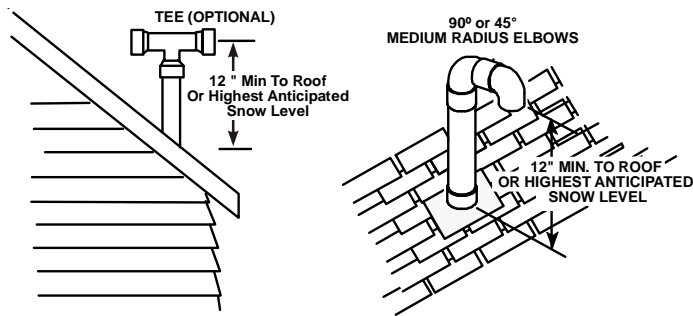

NOTE: Care should be taken to prevent condensate accumulations on roofing material.

Alternate Vertical Termination (Single Pipe)

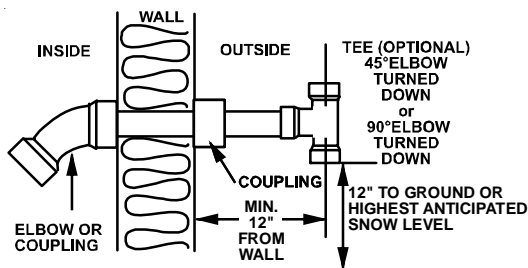

Horizontal Termination (Single Pipe)

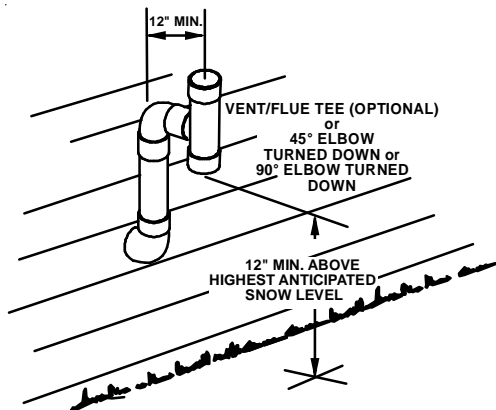

Horizontal Termination (Single Pipe) Above Highest Anticipated Snow Level

DIRECT VENT (DUAL PIPE) PIPING

The inlet air screens provided in the installation instruction packet are available for the installer to use in the inlet of the combustion air pipe to prevent animals from building nests in the combustion air pipe. Installation of screens, while strongly recommended, is not required and will not affect performance of the unit.

Direct vent installations require both a combustion air intake and a vent/flue pipe. The pipes may be run horizontally and exit through the side of the building or run vertically and exit through the roof of the building. The pipes may be run through an existing *unused* chimney; however, they must extend a minimum of 12 inches above the top of the chimney. The space between the pipes and the chimney must be closed with a weather tight, corrosion resistant flashing. Both the combustion air intake and a vent/flue pipe terminations must be in the same atmospheric pressure zone. Refer to *Vent/Flue and Combustion Air Pipe - Termination Locations* or *Concentric Vent Termination* for specific details on termination construction. For details concerning connection of pipes to the furnace, refer to the *Vent/Flue Pipe and Combustion Pipe - Standard Furnace Connections* or *Alternate Furnace Connections*.

VENT/FLUE & COMBUSTION AIR PIPE LENGTHS & DIAMETERS

Refer to the following table for applicable length, elbows, and pipe diameter for construction of the vent/flue and combustion air intake pipe systems of a direct vent (dual pipe) installation. The number of elbows tabulated represents the number of elbows and/or tees in each (Vent/Flue & Combustion Air Intake) pipe. If there is a difference between the two pipes, count the pipe with the most fittings. Elbows and/or tees used in the terminations must be included when determining the number of elbows in the piping systems.

If the combustion air intake pipe is to be installed above a finished ceiling or other area where dripping of condensate will be objectionable, insulation of the combustion air pipe may be required. Use 1/2" thick closed cell foam insulation such as Armaflex™ or Insultube™ where required.

VENT/FLUE AND COMBUSTION AIR PIPE TERMINATIONS

The vent/flue and combustion air pipes may terminate vertically, as through a roof, or horizontally, as through an outside wall.

UPFLOW										
Direct Vent (Dual Pipe) Maximum Allowable Length* of Vent/Flue & Combustion Air Intake Pipe ⁽¹⁾										
Unit Input (Btu)	Termination Style	Pipe ⁽⁴⁾ (inch)	Number of Elbows ⁽¹⁾⁽²⁾⁽³⁾⁽⁵⁾							
			1	2	3	4	5	6	7	8
60,000	Standard	2 or 2 1/2	49	46	43	40	37	34	31	28
		3	71	68	65	62	59	56	53	50
60,000	Alternate	2 or 2 1/2	36	33	30	27	24	21	18	15
		3	57	54	51	48	45	42	39	36
80,000	Standard	3	71	68	65	62	59	56	53	50
		3	57	54	51	48	45	42	39	36
100,000	Standard	3	49	46	43	40	37	34	31	28
		3	35	32	29	26	23	20	17	14

*Maximum allowable limits listed are individual lengths for inlet & flue and NOT a combination.

COUNTERFLOW										
Direct Vent (Dual Pipe) Maximum Allowable Length* of Vent/Flue & Combustion Air Intake Pipe ^(*)										
Unit Input (Btu)	Termination Style	Pipe ⁽⁴⁾ (inch)	Number of Elbows ⁽¹⁾⁽²⁾⁽³⁾⁽⁵⁾							
			1	2	3	4	5	6	7	8
60,000	Standard	2 or 2 1/2	49	46	43	40	37	34	31	28
		3	71	68	65	62	59	56	53	50
	Alternate	2 or 2 1/2	36	33	30	27	24	21	18	15
		3	57	54	51	48	45	42	39	36
80,000	Standard	2 or 2 1/2	61	58	55	52	49	46	43	40
		3	71	68	65	62	59	56	53	50
	Alternate	2 or 2 1/2	48	45	42	39	36	33	30	27
		3	57	54	51	48	45	42	39	36
100,000	Standard	3	71	68	65	62	59	56	53	50
	Alternate	3	57	54	51	48	45	42	39	36

*Maximum allowable limits listed are individual lengths for inlet & flue and NOT a combination.

- 1) Elbows and/or tees used in terminations must be included when determining quantity of allowable elbows in the system.
- 2) Number of elbows tabulated are for each (Vent/Flue & Combustion Air Intake) pipe.
- 3) Minimum requirements for each Vent/Flue & Combustion Air Intake pipe is five (5) feet in length and one elbow/tee.
- 4) 2 1/2" or 3" diameter pipe can be used in place of 2" diameter pipe.
- 5) Increased Clearance Configurations using (2) 45 deg. Long Sweep elbows should be considered equivalent to one 90 deg. elbow.

Vertical pipe terminations should be as shown in the following figure. Refer to *Vent/Flue Pipe and Combustion Pipe - Termination Locations* for details concerning location restrictions. The penetrations through the roof must be sealed tight with proper flashing such as is used with a plastic plumbing vent.

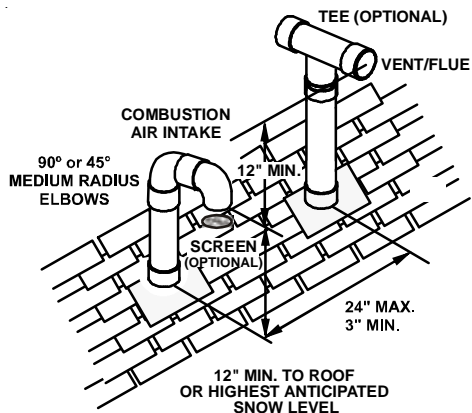
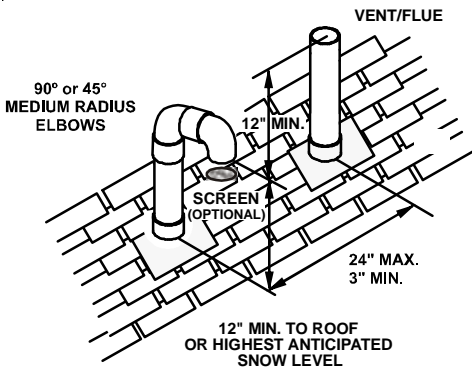

Vertical Terminations (Dual Pipe)

Horizontal terminations should be as shown in the following figure. Refer to *Vent/Flue Pipe and Combustion Pipe - Termination Location* for location restrictions. A 2 3/8" diameter wall penetration is required for 2" diameter pipe. A 3" diameter hole is required for a 2 1/2" pipe and a 3 1/2" diameter hole is required for 3" diameter pipe. To secure the pipe passing through the wall and prohibit damage to piping connections, a coupling should be installed on either side of the wall and solvent cemented to a pipe connecting the two couplings. The pipe length should be the wall thickness plus the depth of the socket fittings to be installed on the inside and outside of the wall. The wall penetration should be sealed with silicone caulking material.

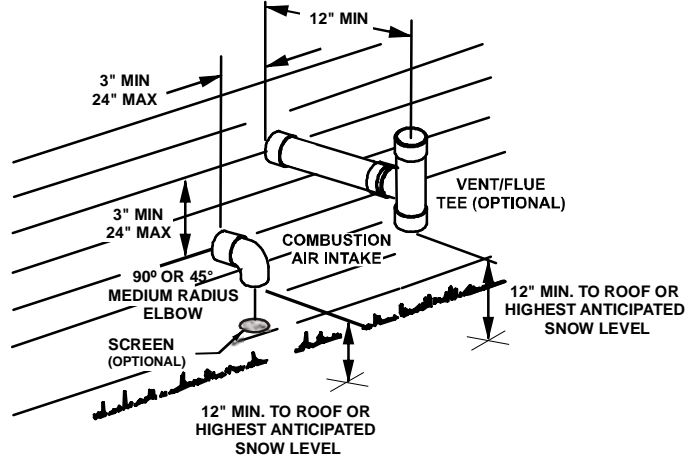

Standard Horizontal Terminations (Dual Pipe)

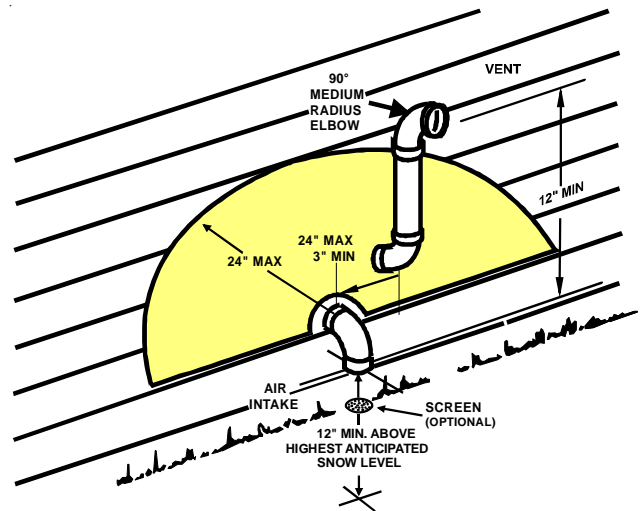

Alternate Horizontal Vent Termination (Dual Pipe)

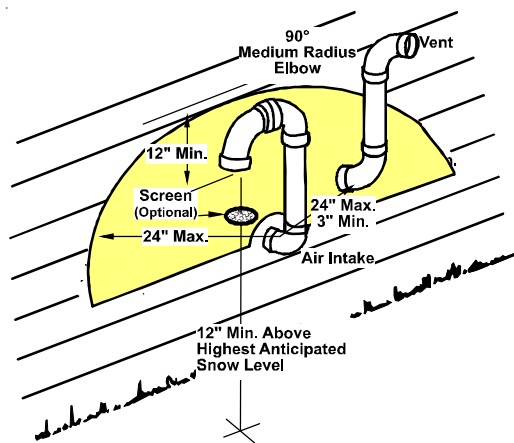

Alternate Vent Termination Above Anticipated Snow Level (Dual Pipe)

In a basement installation, the pipes may be run between the joist spaces. If the pipes must go below the joist and then up into the last joist space to penetrate the header, two 45° elbows should be used to reach the header rather than two 90° elbows.

VENT/INTAKE TERMINATIONS FOR INSTALLATION OF MULTIPLE DIRECT VENT FURNACES

If more than one direct vent furnace is to be installed vertically through a common roof top, maintain the same minimum clearances between the exhaust vent and air intake terminations of adjacent units as with the exhaust vent and air intake terminations of a single unit.

If more than one direct vent furnace is to be installed horizontally through a common side wall, maintain the clearances as in the following figure. Always terminate all exhaust vent outlets at the same elevation and always terminate all air intakes at the same elevation.

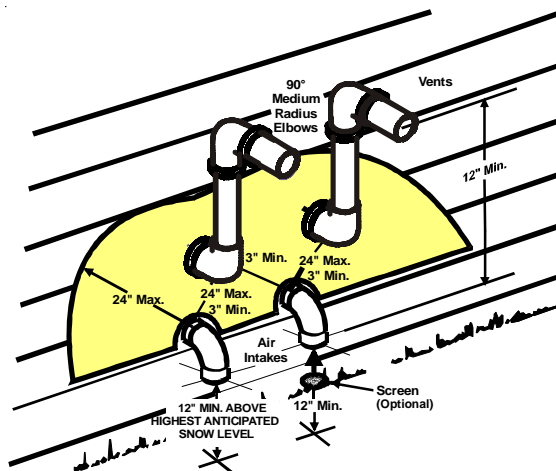

Horizontal Venting Of Multiple Units

CONCENTRIC VENT TERMINATION

Refer to the directions provided with the Concentric Vent Kit (DCVK) for installation specifications.

SIDE WALL VENT KIT

This kit is to be used with 2" or 3" direct vent systems. The vent kit must terminate outside the structure and may be installed with the intake and exhaust pipes located side-by-side or with one pipe above the other. This kit is **NOT** intended for use with single pipe (indirect vent) installations.

Refer to the directions furnished with the Side Wall Vent Kit (p/n 0170K00000S) for installation specifications.

CONDENSATE DRAIN LINES & DRAIN TRAP

A condensing gas furnace achieves its high level of efficiency by extracting almost all of the heat from the products of combustion and cooling them to the point where condensation takes place. The condensate which is generated must be piped to an appropriate drain location.

In *upright* installations, the furnace's drain hoses may exit either the right or left side of the furnace. **NOTE:** If the alternate vent/flue outlet is utilized in an upright installation, the drain trap and drain connections must be located on the same side as the alternate vent/flue outlet.

In *horizontal* installations, the drain hoses will exit through the bottom (down side) of the unit with the drain trap suspended beneath the furnace. The field-supplied drain system must be in accordance with all local codes and the instructions in the following sections.

Follow the bullets listed below when installing the drain system. Refer to the following sections for specific details concerning furnace drain trap installation and drain hose hook ups.

- The drain trap supplied with the furnace must be used.
- The drain line between furnace and drain location must be constructed of 3/4" PVC.
- The drain line between furnace and drain location must maintain a 1/4 inch per foot downward slope toward the drain.
- Do not trap the drain line in any other location than at the drain trap supplied with the furnace.
- Do not route the drain line outside where it may freeze.
- If the drain line is routed through an area which may see temperatures near or below freezing, precautions must be taken to prevent condensate from freezing within the drain line.
- If an air conditioning coil is installed with the furnace, a common drain may be used. An open tee must be installed in the drain line, near the cooling coil, to relieve positive air pressure from the coil's plenum. This is necessary to prohibit any interference with the function of the furnace's drain trap.

NOTE: In vertical installations, air conditioning coil condensate may drain into the furnace trap as long as there is a trap between the coil and the furnace trap and the drain pipe is not terminating below the water level of the furnace trap.

STANDARD RIGHT OR LEFT SIDE DRAIN HOSE CONNECTIONS

All installation positions require the use of the drain trap, hoses, tubes, and clamps. The following quantity of hoses, tubes, and hose clamps are provided with the unit.

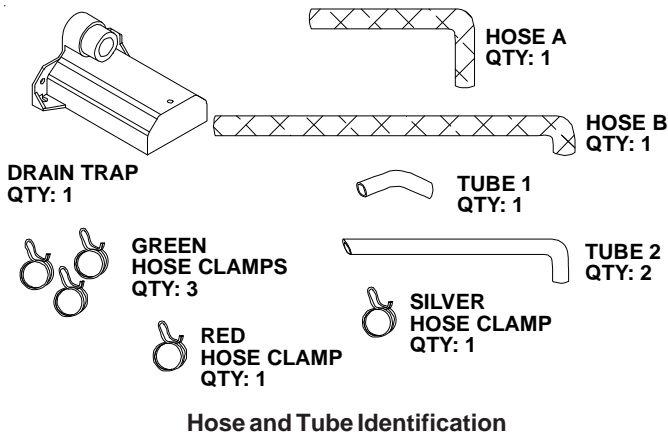

UPRIGHT INSTALLATIONS-TRAP ON RIGHT SIDE

In an upright installation drain hoses are connected to drain ports on the rubber elbow and the recuperator coil front cover. The drain lines are then routed through the right side panel and into the drain trap secured to the outside of the cabinet.

NOTE: Refer to *Alternate Vent/Flue Hose Connections* for upright installations using an alternate vent/flue outlet.

1. Remove the rubber plug from the right side of the front cover drain port.
2. Secure Hose A to front cover drain port with a red hose clamp. Route hose to rear side panel grommet hole.
3. Cut and remove 1/4 inch from the end of the drain port on the rubber elbow.
4. Insert Tube 1 into rubber elbow drain port and secure with silver hose clamp. Angle tube outward toward front of furnace.
5. Cut 17 3/4 inches from the long end of Hose B and discard. Secure the remaining hose to Tube 1 with a green hose clamp. Route the other end of Hose B to front right side panel grommet hole.

For details concerning mounting of the drain trap, refer to *Horizontal Drain Trap Mounting*.

6. Insert short end of each of tube 2 through side panel grommet holes. Secure tubes to hoses A and B with green hose clamps. Ensure hoses and tubes maintain a downward slope for proper drainage and that they are not kinked or binding.

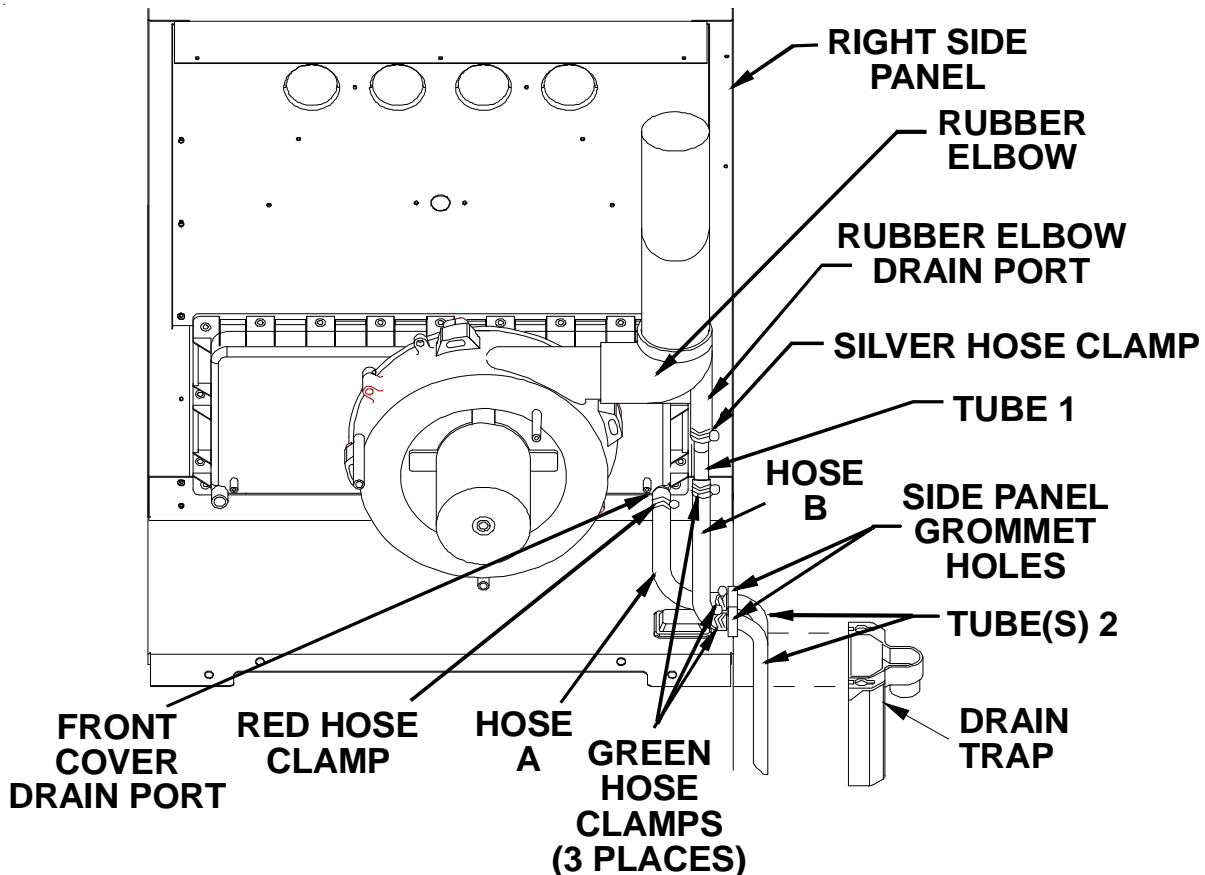

Upright "Standard" Connections - Right Side
(Upflow Shown, Counterflow Similar)

ALTERNATE VENT/FLUE DRAIN HOSE CONNECTIONS

Upright installations using the *alternate vent/flue outlet* will require "right-side only" drain hoses to be connected as follows. Refer to *Vent/Flue Pipe and Combustion Air Pipe* for details on alternate vent/flue pipe connection.

1. Remove the rubber plug/cap from the right-side drain port on the front cover. Save for use in step 3.
2. Secure Hose A to front cover drain port with a red hose clamp. Route hose to rear right side panel grommet hole.
3. Remove grommet from front right-side panel drain hole. Seal hole in grommet with large end of plug. Reinstall grommet and plug into side panel drain hole.
4. Cut 1/4 inch from the end of the drain port on the externally mounted rubber elbow. Discard cut portion.
5. Insert Tube 1 into rubber elbow drain port and secure with a silver hose clamp. Angle tube toward trap.
6. Cut 17 3/4 inches from the long end of Hose B and discard.
7. Secure straight end of Hose B to exposed end of Tube 1 with a green hose clamp. Route hose toward right side panel grommet holes.
8. Insert short end of one Tube 2 through rear right side panel grommet drain hole. Secure tube to Hose A with a green hose clamp.
9. Insert short end of remaining Tube 2 into Hose B from rubber elbow and secure with green hose clamp. Ensure hoses and tubes maintain a downward slope for proper drainage and are not kinked or binding.

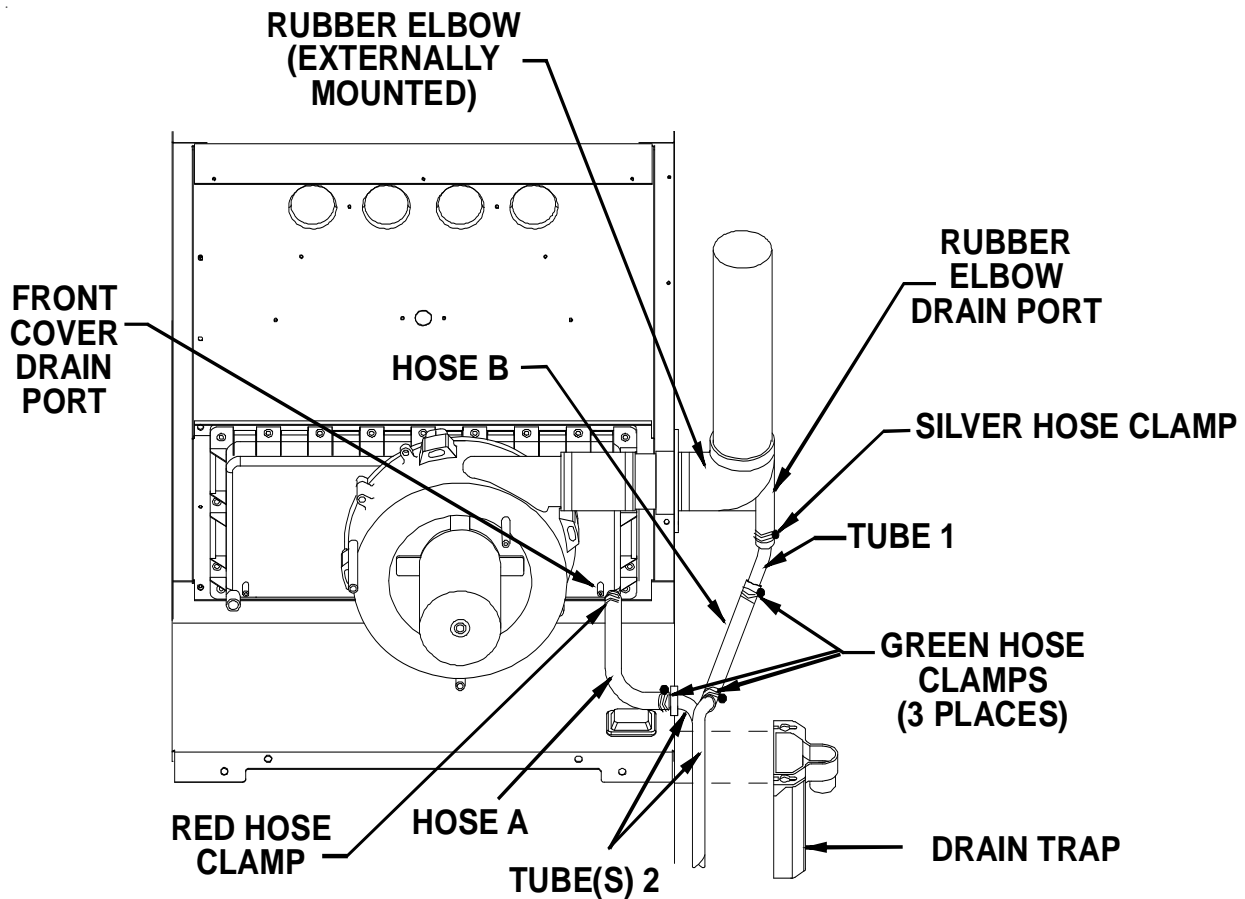

Upright "Alternate" Connections - Right Side Only
(Upflow Shown, Counterflow Similar)

UPRIGHT INSTALLATIONS-TRAP ON LEFT SIDE

NOTE: For left side trap installation, grommets must be moved to the left side of the furnace and the plugs installed on the right side of the furnace.

1. Remove the rubber plug/cap from the left side drain port on the front cover.
2. Secure Hose A to front cover drain port with a red hose clamp. Route hose to rear side panel grommet hole.
3. Cut and remove 1/4 inch from the end of the drain port on the rubber elbow.
4. Insert Tube 1 into rubber elbow drain port and secure with silver hose clamp. Angle tube outward toward front of furnace.

5. Cut "X" inches from the long end of Hose B and discard. Refer to table for appropriate length to cut. Secure remaining hose to Tube 1 with a green hose clamp. Route other end of Hose B to front left side panel grommet hole.

NOTE: Long hose "B" must always be connected to Tube 1 and the elbow and not on the front cover.

6. Insert short end of each Tube 2 through side panel grommet holes. Secure tubes to Hose A and Hose B with green hose clamps. Ensure hoses and tubes maintain a downward slope for proper drainage and that they are not kinked or binding.

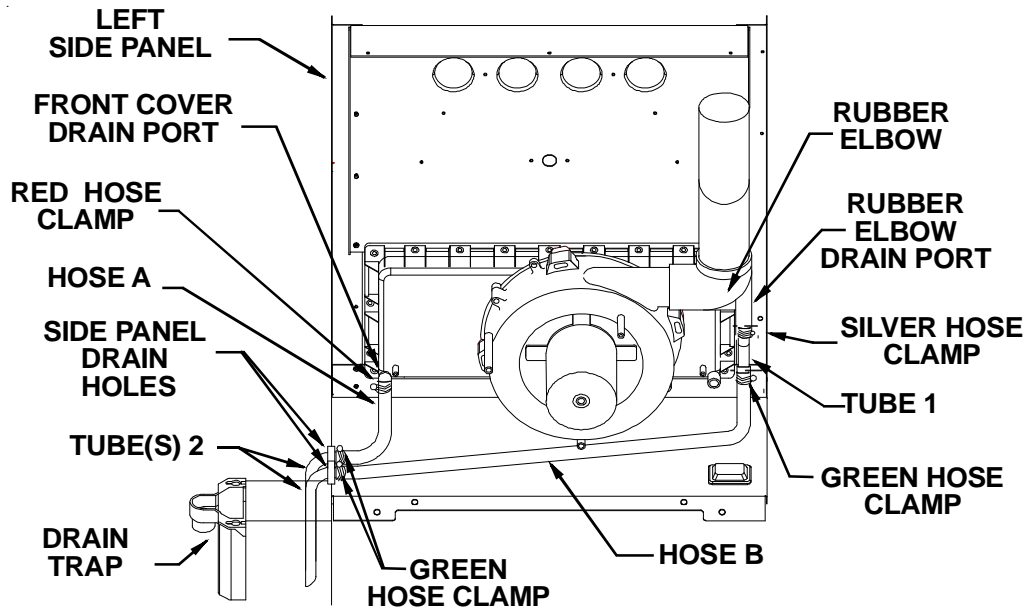

Upright "Standard" Connections - Left Side
(Upflow Shown, Counterflow Similar)

Cabinet Width (inches)	Models (kBTU_Tons)	"X" Length to Cut From Long End of Hose B (inches)
17 1/2	60_3	7
21	60_4	3 1/2
	80_5	
24 1/2	80_5	None
	100_5	
	115_5	

UPRIGHT DRAIN TRAP MOUNTING (LEFT OR RIGHT SIDE PANEL)

1. Insert drain tubes into drain trap and position the drain trap against the side panel. **NOTE:** Drain tubes must reach the bottom of the drain trap.

2. Secure drain trap to side panel at the mounting holes (dimples or crosshairs on counterflow models) located below the grommet drain holes.
3. Attach PVC drain line to drain trap outlet with either a 90° elbow or coupling.

HORIZONTAL INSTALLATIONS

RIGHT SIDE DOWN

Horizontal installations with the right side down require that the drain hoses be connected to the right side front cover drain port and the rubber elbow drain port.

NOTE: On counterflow models, relocation of the front cover pressure switch hose is required.

Make connections as follows:

1. Remove the rubber plug/cap from right side of the front cover drain port.

Counterflow furnaces

Relocate the front cover pressure switch hose connection from the left side pressure tap to the right (down) side tap. The pressure switch hose must be connected to the down side to guard against blocked drain conditions. Cut hose to appropriate length to minimize sagging. Plug left (unused) pressure tap with plug removed from right side.

2. Secure Hose A to front cover drain tap with a red hose clamp. Route hose to rear right (down) side panel grommet holes.
3. Cut 1/4 inch from the end of the drain port on the rubber elbow and discard.
4. Insert Tube 1 into rubber elbow drain port and secure with a silver hose clamp. Angle tube outward toward front of furnace.
5. Cut 17 3/4 inches from the long end of Hose B and discard.
6. Secure remaining end of Hose B to exposed end of Tube 1 with a green hose clamp. Route hose to front right down side panel grommet holes.
7. Cut 5 1/2 inches straight length from the long end of each Tube 2 and discard the radius pieces.
8. Insert approximately one inch of each Tube 2 through the right down side panel grommet holes. Secure tubes to Hose A and Hose B using green hose clamps. Ensure hoses and tubes maintain a downward slope for proper drainage and are not kinked or bound.

For details concerning mounting of the drain trap, refer to *Condensate Drain Lines and Drain Trap - Horizontal Drain Trap Mounting*.

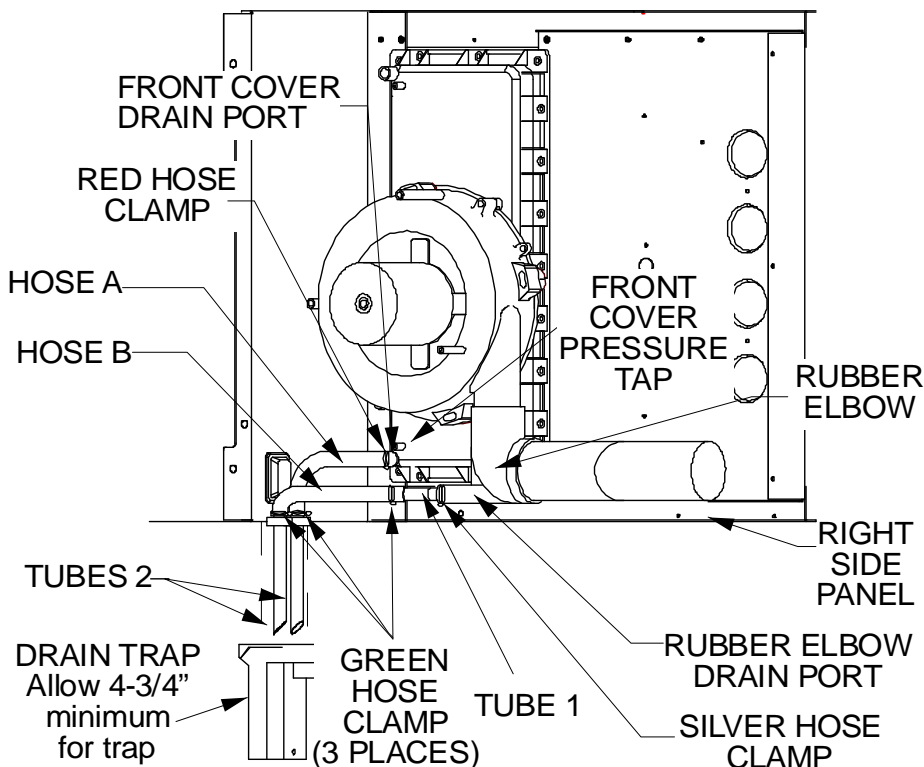

Horizontal Connections - Right Side Down
(Upflow Shown, Counterflow Similar)

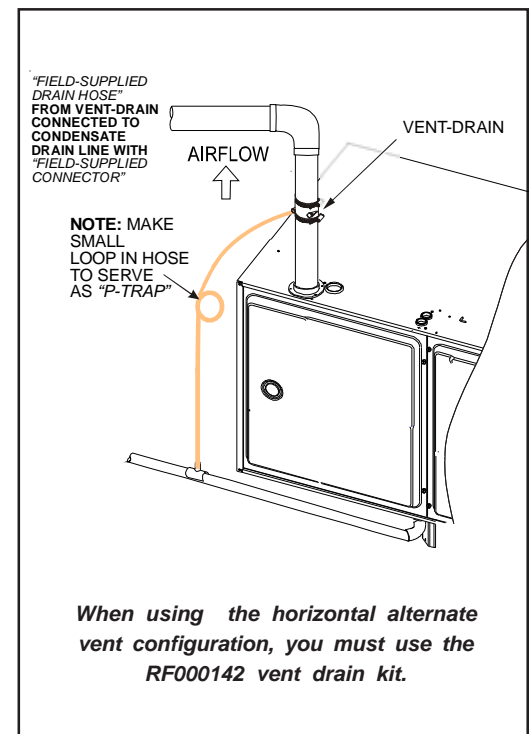

When using the horizontal alternate vent configuration, you must use the RF000142 vent drain kit.

Horizontal installations with the left side panel down will require drain hoses to be connected to the left side front cover drain port and the side drain port on the rubber elbow.

1. Remove the rubber plug/cap from the front cover left (down) side drain port.
2. Relocate the front cover pressure switch hose connection from the right side (as shipped) pressure tap to the left (down) side tap. The pressure switch hose must be connected to the down side to guard against blocked drain conditions. Cut hose to appropriate length to minimize sagging. Plug right (unused) pressure tap with plug removed from left side.
3. Secure Hose A to front cover drain port with a red hose clamp. Route hose to rear left (down) side panel grommet holes. **NOTE:** For left side drainage, grommets must be relocated to left side panel.
4. Remove the rubber cap from the side drain port on the rubber elbow.
5. Secure the short end of Hose B to rubber elbow side drain port using a green hose clamp. **NOTE:** For left side drainage, route hose to far left (down) side panel grommet holes. **NOTE:** Horizontal left side connections (when using new side port drain elbow) does not require connecting a hose to the induced draft blower housing.
6. Cut 5 1/2 inches straight length from the long end of each Tube 2 and discard radius ends.

7. Insert approximately one inch of each Tube 2 through left side panel grommet hole. Secure tubes to Hose A and Hose B with a green hose clamps. **NOTE:** Tube must reach bottom of trap. Ensure hoses and tubes maintain a downward slope for proper drainage and that they are not kinked or binding.

For details concerning mounting of the drain trap, refer to *Condensate Drain Lines and Drain Trap - Horizontal Drain Trap Mounting*.

HORIZONTAL DRAIN TRAP MOUNTING (LEFT OR RIGHT SIDE PANEL)

1. Position the drain trap against side panel with drain tubes inserted into trap. Note that the trap may be orientated with the outlet facing either the furnace's top cover or base pan.
2. Secure drain trap to side panel at the dimples or crosshairs located on either side of the grommet drain holes.
3. Confirm that tubes reach bottom of drain trap and that all hoses maintain a downward slope and are not kinked or binding.
4. Attach PVC drain line to drain trap outlet with either a 90° elbow or coupling.

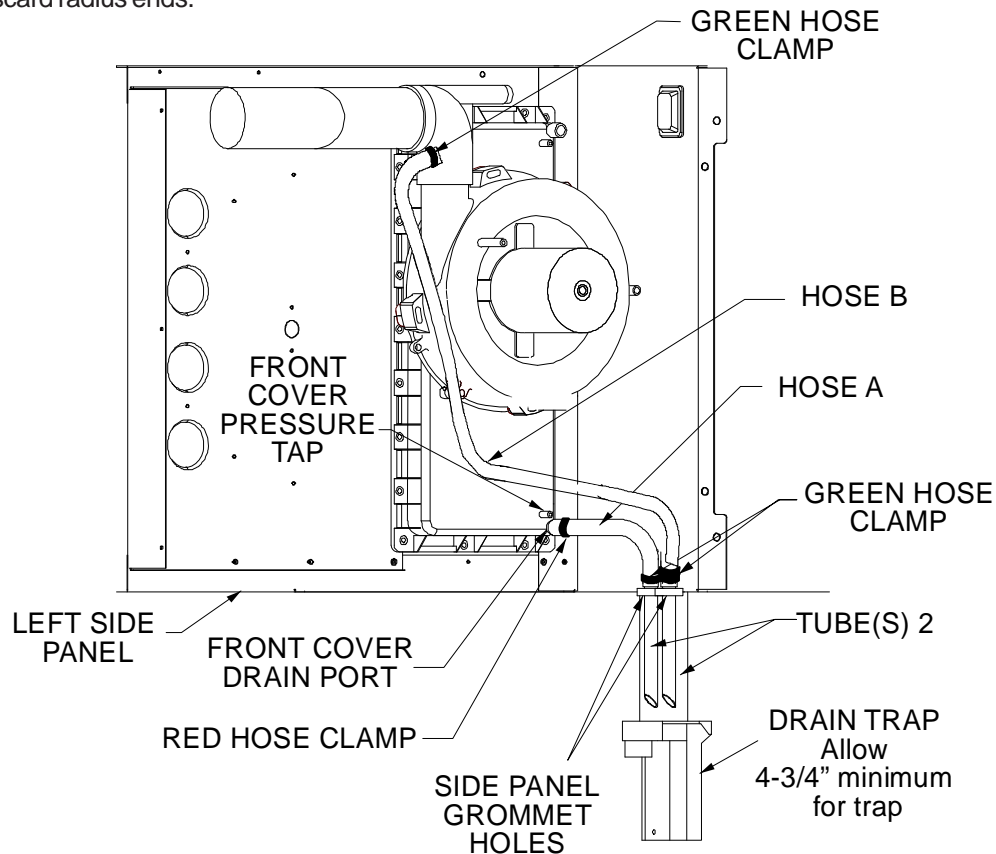

Horizontal Connections - Left Side Down
(Upflow Shown, Counterflow Similar)

ELECTRICAL CONNECTIONS

 **WARNING**

HIGH VOLTAGE !

TO AVOID THE RISK OF ELECTRICAL SHOCK, WIRING TO THE UNIT MUST BE POLARIZED AND GROUNDED.



 **WARNING**

HIGH VOLTAGE !

TO AVOID PERSONAL INJURY OR DEATH DUE TO ELECTRICAL SHOCK, DISCONNECT ELECTRICAL POWER BEFORE SERVICING OR CHANGING ANY ELECTRICAL WIRING.



 **CAUTION**

LABEL ALL WIRES PRIOR TO DISCONNECTION WHEN SERVICING CONTROLS. WIRING ERRORS CAN CAUSE IMPROPER AND DANGEROUS OPERATION. VERIFY PROPER OPERATION AFTER SERVICING.

WIRING HARNESS

The wiring harness is an integral part of this furnace. Field alteration to comply with electrical codes should not be required. Wires are color coded for identification purposes. Refer to the wiring diagram for wire routings. If any of the original wire as supplied with the furnace must be replaced, it must be replaced with wiring material having a temperature rating of at least 105° C. Any replacement wiring must be a copper conductor.

115 VOLT LINE CONNECTIONS

Before proceeding with electrical connections, ensure that the supply voltage, frequency, and phase correspond to that specified on the unit rating plate. Power supply to the furnace must be NEC Class 1, and must comply with all applicable codes. The furnace must be electrically grounded in accordance with local codes or, in their absence, with the latest edition of The National Electric Code, ANSI NFPA 70 and/or The Canadian Electric Code CSA C22.1.

Use a separate fused branch electrical circuit containing properly sized wire, and fuse or circuit breaker. The fuse or circuit breaker must be sized in accordance with the maximum overcurrent protection specified on the unit rating plate. An electrical disconnect must be provided at the furnace location.

Connect hot, neutral, and ground wires as shown in the wiring diagram located on the unit's blower door. For direct vent applications, the cabinet opening to the junction box must be sealed air tight using either an UL approved bushing such as Heyco Liquid Tight or by applying non-reactive UL approved sealant to bushing.

Line polarity must be observed when making field connections. Line voltage connections can be made through either the right or left side panel. The furnace is shipped configured for a right side (left side for counterflows) electrical connection with the junction box located inside the burner compartment. To make electrical connections through the opposite side of the furnace, the junction box must be relocated to the other side of the burner compartment prior to making electrical connections. To relocate the junction box, follow the steps shown below.

NOTE: Wire routing must not to interfere with circulator blower operation, filter removal, or routine maintenance.

JUNCTION BOX RELOCATION

 **WARNING**

EDGES OF SHEET METAL HOLES MAY BE SHARP. USE GLOVES AS A PRECAUTION WHEN REMOVING HOLE PLUGS.

 **WARNING**

TO PREVENT PERSONAL INJURY OR DEATH DUE TO ELECTRIC SHOCK, DISCONNECT ELECTRICAL POWER BEFORE INSTALLING OR SERVICING THIS UNIT.

 **WARNING**

HIGH VOLTAGE !

TO AVOID THE RISK OF INJURY, ELECTRICAL SHOCK OR DEATH, THE FURNACE MUST BE ELECTRICALLY GROUNDED IN ACCORDANCE WITH LOCAL CODES OR IN THEIR ABSENCE, WITH THE LATEST EDITION OF THE NATIONAL ELECTRIC CODE.



Line voltage connections can be made through either the right or left side panel. The furnace is shipped configured for a right side electrical connection. To make electrical connections through the opposite side of the furnace, the junction box must be relocated to the left side prior to making electrical connections. To relocate the junction box, perform the following steps.

1. Remove the burner compartment door.
2. Remove and save the two screws securing the junction box to the side panel.
3. Relocate junction box and associated plugs and grommets to opposite side panel. Secure with screws removed in step 2.

 **WARNING**

TO AVOID THE RISK OF INJURY, ELECTRICAL SHOCK OR DEATH, THE FURNACE MUST BE ELECTRICALLY GROUNDED IN ACCORDANCE WITH LOCAL CODES OR, IN THEIR ABSENCE, WITH THE LATEST EDITION OF THE NATIONAL ELECTRIC CODE.

To ensure proper unit grounding, the ground wire should run from the furnace ground screw located inside the furnace junction box all the way back to the electrical panel. **NOTE:** Do not use gas piping as an electrical ground. To confirm proper unit grounding, turn off the electrical power and perform the following check.

1. Measure resistance between the neutral (white) connection and one of the burners.
2. Resistance should measure 10 ohms or less.

This furnace is equipped with a blower door interlock switch which interrupts unit voltage when the blower door is opened for servicing. Do not defeat this switch.

24 VOLT THERMOSTAT WIRING

IMPORTANT NOTE

WIRE ROUTING MUST NOT INTERFERE WITH CIRCULATOR BLOWER OPERATION, FILTER REMOVAL OR ROUTINE MAINTENANCE.
A REMOVABLE PLUG CONNECTOR IS PROVIDED WITH THE CONTROL TO MAKE THERMOSTAT WIRE CONNECTIONS. THIS PLUG MAY BE REMOVED, WIRE CONNECTIONS MADE TO THE PLUG, AND REPLACED. IT IS **STRONGLY RECOMMENDED THAT MULTIPLE WIRES INTO A SINGLE TERMINAL BE TWISTED TOGETHER PRIOR TO INSERTING INTO THE PLUG CONNECTOR. FAILURE TO DO SO MAY RESULT IN INTERMITTENT OPERATION.**

IMPORTANT NOTE

DIP SWITCH #13 MUST BE SET TO MATCH THERMOSTAT TYPE. TO USE THE CTK01AA COMMUNICATING THERMOSTAT, DIP SWITCH #13 MUST BE SET TO ON POSITION. THIS IS ALSO THE CORRECT SETTING FOR A NON-COMMUNICATING 2-STAGE THERMOSTAT. TO USE CTK02AA MODULATING THERMOSTAT, CHECK TO MAKE SURE DIP SWITCH #13 IS IN THE OFF POSITION (FACTORY POSITION). THIS IS ALSO THE CORRECT POSITION WHEN USING A NON-COMMUNICATING SINGLE-STAGE THERMOSTAT.

As a two-stage non-communicating furnace, the furnace integrated control module provides terminals for both "W1" and "W2", and "Y1" and "Y2" thermostat connections. This allows the furnace to support the following system applications: 'Two-Stage Heating Only', 'Two-Stage Heating with Single Stage Cooling', and 'Two-Stage Heating with Two-Stage Cooling'. Refer to the following figures for proper connections to the integrated control module.

Low voltage connections can be made through either the right or left side panel. Thermostat wiring entrance holes are located in the blower compartment. The following figure shows connections for a "heat/cool system".

This furnace is equipped with a 40 VA transformer to facilitate use with most cooling equipment. Consult the wiring diagram, located on the blower compartment door, for further details of 115 Volt and 24 Volt wiring.

NOTE: Use of ramping profiles requires a jumper between Y1 and O.

IMPORTANT NOTE

THERMOSTAT "R" REQUIRED IF OUTDOOR UNIT IS EQUIPPED WITH A COMFORT ALERT™ MODULE OR IF THE OUTDOOR UNIT IS A PART OF THE CONFORTNET™ FAMILY OF EQUIPMENT.



The auxiliary contacts are shipped with a factory installed jumper. As an option, the auxiliary contacts may be wired to a normally closed float switch. In the event of open contacts, the furnace will be disabled until the condition is corrected. These are 24 volt terminals fed internally, do not apply another voltage source to these terminals.

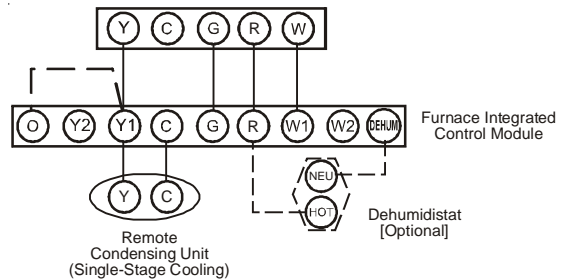

Thermostat - Single-Stage Heating with Single-Stage Cooling

IMPORTANT NOTE

TO APPLY A SINGLE-STAGE HEATING THERMOSTAT, THE THERMOSTAT SELECTOR SWITCH ON THE INTEGRATED CONTROL MODULE MUST BE SET ON SINGLE-STAGE.

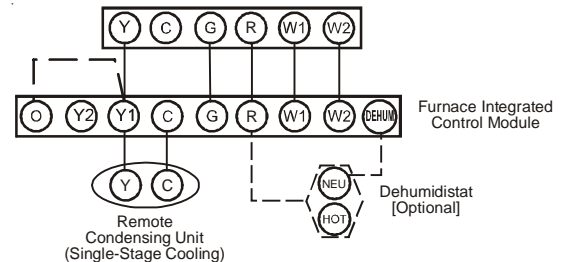

Thermostat - Two-Stage Heating with Single-Stage Cooling

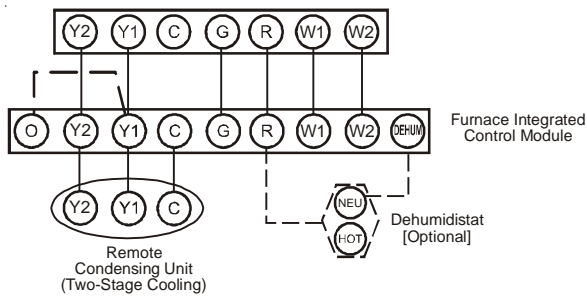

Thermostat - Two-Stage Heating with Two-Stage Cooling

IMPORTANT NOTE

SET DIP SWITCH #14 TO ON POSITION WHEN USING A 2-STAGE COOLING THERMOSTAT.

Thermostat Wiring Diagrams

SINGLE-STAGE HEATING THERMOSTAT APPLICATION

A single-stage thermostat with only one heating stage may be used to control this furnace.

To use a single-stage thermostat, turn off power to the furnace, move the thermostat selection DIP switch to the OFF position. Turn power back on. Refer to the dip switch chart in this manual.

24 VOLT DEHUMIDISTAT WIRING

The optional usage of a dehumidistat allows the furnace’s circulator blower to operate at a slightly lower speed (85% of desired speed) during a combined thermostat call for cooling and dehumidistat call for dehumidification. This can be done through an independent dehumidistat or through a thermostat’s DEHUM terminal (if available). This lower blower speed enhances dehumidification of the conditioned air as it passes through the AC coil. For proper function, a dehumidistat applied to this furnace must operate on 24 VAC and utilize a switch which *opens on humidity rise*. Refer to the “Thermostat Wiring Diagrams” figure for additional wiring details.

To install/connect a dehumidistat:

1. Turn OFF power to furnace.
2. Secure the dehumidistat neutral wire (typically the white lead) to the terminal marked “DEHUM” on the furnace integrated control module.
3. Secure the dehumidistat hot wire (typically the black lead) to the terminal marked “R” on the furnace integrated control module.
4. Secure the dehumidistat ground wire (typically the green lead) to the ground screw on the furnace junction box.
NOTE: Ground wire may not be present on all dehumidistats.
5. Turn ON power to furnace.

To enable the dehumidify function on the integrated control module, set the dehumidification ENABLE dipswitch from OFF to ON.

Once the switch is set, the dehumidify function is enabled during a *combination* call for cooling (T-Stat) and dehumidification (DEHUM-Stat). Refer to the dip switch chart in the back section of this manual.

FOSSIL FUEL APPLICATIONS

This furnace can be used in conjunction with a heat pump in a fossil fuel application. A fossil fuel application refers to a combined gas furnace and heat pump installation which uses an outdoor temperature sensor to determine the most cost efficient means of heating (heat pump or gas furnace).

A heat pump thermostat with *three stages of heat* is required to properly use a two-stage furnace in conjunction with a heat pump. Refer to the fossil fuel kit installation instructions for additional thermostat requirements.

Strictly follow the wiring guidelines in the fossil fuel kit installation instructions. All furnace connections must be made to the furnace two-stage integrated control module and the “FURNACE” terminal strip on the fossil fuel control board.

115 VOLT LINE CONNECTION OF ACCESSORIES (HUMIDIFIER AND ELECTRONIC AIR CLEANER)

⚠ WARNING

HIGH VOLTAGE !

TO AVOID PERSONAL INJURY OR DEATH DUE TO ELECTRICAL SHOCK, DISCONNECT ELECTRICAL POWER BEFORE SERVICING OR CHANGING ANY ELECTRICAL WIRING.

The furnace integrated control module is equipped with line voltage accessory terminals for controlling power to an electronic air cleaner.

The accessory load specifications are as follows. (The furnace control board also has a set of dry contacts for humidifier connection.)

Humidifier	1.0 Amp maximum at 120 VAC
Electronic Air Cleaner	1.0 Amp maximum at 120 VAC

Turn OFF power to the furnace before installing any accessories. Follow the humidifier or air cleaner manufacturers’ instructions for locating, mounting, grounding, and controlling these accessories. Accessory wiring connections are to be made through the 1/4" quick connect terminals provided on the furnace integrated control module. The Electronic air cleaner hot terminal is identified as EAC. The EAC neutral terminal is identified as NEUTRAL. A line voltage humidifier may be connected between one of the HUM contacts and NEUTRAL. The other HUM contact must be fed from the L1 terminal.

All field wiring must conform to applicable codes. Connections should be made as shown in the following figure.

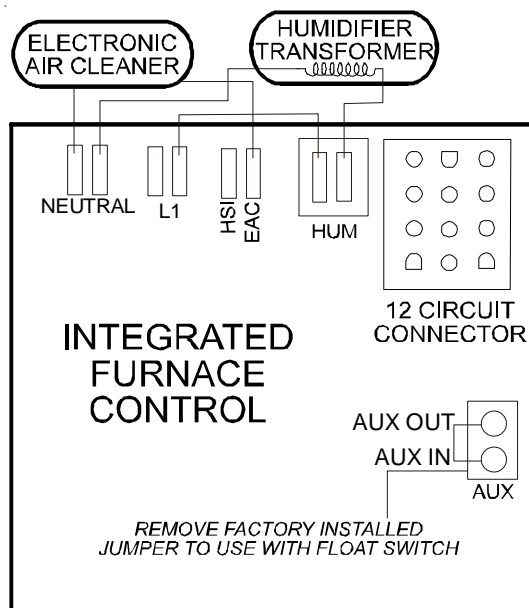

If it is necessary for the installer to supply additional line voltage wiring to the inside of the furnace, the wiring must conform to all local codes, and have a minimum temperature rating of 105°C. All line voltage wire splices must be made inside the furnace junction box.

The integrated furnace control HUM (dry contacts) are closed whenever the inducer is energized in a non-communicating installation. When used with a CTK02AA communicating thermostat, the HUM terminals are closed whenever there is a call for humidity. The integrated control module electronic air cleaner terminals (EAC) are energized with 115 volts whenever the circulator blower is energized.

24 VOLT HUMIDIFIER

A 5" long brown wire in the wire harness at the low fire pressure switch provides 24 VAC humidifier control. This wire is powered any time the pressure switch is closed. To connect 24 VAC HUM, connect the 24 VAC line of the humidifier to the 5" brown wire. The connection can be made by either stripping the wire and using a wire nut or by using a field supplied quick connect terminal. The wiring must conform to all local and national codes. Connect the COM side of the humidifier to the C terminal on the furnace control board (or to the COM side of the 24 VAC transformer). Do not connect 115V humidifier to these terminals.

GAS SUPPLY AND PIPING

The furnace rating plate includes the approved furnace gas input rating and gas types. The furnace must be equipped to operate on the type of gas applied. This includes any conversion kits required for alternate fuels and/or high altitude.

CAUTION

TO PREVENT UNRELIABLE OPERATION OR EQUIPMENT DAMAGE, THE INLET GAS SUPPLY PRESSURE MUST BE AS SPECIFIED ON THE UNIT RATING PLATE WITH ALL OTHER HOUSEHOLD GAS FIRED APPLIANCES OPERATING.

Inlet gas supply pressures must be maintained within the ranges specified in the following table. The supply pressure must be constant and available with all other household gas fired appliances operating. The minimum gas supply pressure must be maintained to prevent unreliable ignition. The maximum must not be exceeded to prevent unit overfiring.

Inlet Gas Supply Pressure		
Natural Gas	Minimum: 5.0" w.c.	Maximum: 10.0" w.c.
Propane Gas	Minimum: 11.0" w.c.	Maximum: 13.0" w.c.

HIGH ALTITUDE DERATE

High altitude kits are purchased according to the installation altitude and usage of either natural or propane gas. Consult the furnace Specification Sheet for appropriate kits.

Do **not** derate the furnace by adjusting the manifold pressure to a lower pressure than specified on the furnace rating plate. The combination of the lower air density and a lower manifold pressure will prohibit the burner orifice from drawing the proper amount of air into the burner. This may cause incomplete combustion, flashback, and possible yellow tipping.

In some areas the gas supplier may artificially derate the gas in an effort to compensate for the effects of altitude. If the gas is artificially derated, the appropriate orifice size must be determined based upon the BTU/ft³ content of the derated gas and the altitude. Refer to the National Fuel Gas Code, NFPA 54/ANSI Z223.1, and information provided by the gas supplier to determine the proper orifice size.

A different pressure switch may be required at high altitude regardless of the BTU/ft³ content of the fuel used. Consult the furnace Specification Sheet for pressure switch.

PROPANE GAS CONVERSION

WARNING

POSSIBLE PROPERTY DAMAGE, PERSONAL INJURY OR DEATH MAY OCCUR IF THE CORRECT CONVERSION KITS ARE NOT INSTALLED. THE APPROPRIATE KITS MUST BE APPLIED TO ENSURE SAFE AND PROPER FURNACE OPERATION. ALL CONVERSIONS MUST BE PERFORMED BY A QUALIFIED INSTALLER OR SERVICE AGENCY.

This unit is configured for natural gas. The appropriate manufacturer's propane gas conversion kit, must be applied for propane gas installations. Refer to the *Propane Gas and/or High Altitude Installations* for details.

Consult the furnace Specification Sheet for a listing of appropriate kits. The indicated kits must be used to insure safe and proper furnace operation. All conversions must be performed by a qualified installer, or service agency.

GAS VALVE

This unit is equipped with a 24 volt gas valve which modulates by pneumatic linkage to the combustion air blower. Taps for measuring the gas supply pressure and manifold pressure are provided on the valve. This is a non-convertible gas valve equipped for natural gas.

The gas valve has a manual ON/OFF control located on the valve itself. This control may be set only to the "ON" or "OFF" position. Refer to the lighting instructions label or *Startup Procedure & Adjustment* for use of this control during start up and shut down periods.

GAS PIPING CONNECTIONS



WARNING

TO AVOID POSSIBLE UNSATISFACTORY OPERATION OF EQUIPMENT DAMAGE DUE TO UNDERFIRING OR EQUIPMENT, USE THE PROPER SIZE OF NATURAL/PROPANE GAS PIPING NEEDED WHEN RUNNING PIPE FROM THE METER/TANK TO THE FURNACE.

When sizing a trunk line, be sure to include all appliances which will operate simultaneously when sizing a trunk line.

The gas piping supplying the furnace must be properly sized based on the gas flow required, specific gravity of the gas, and length of the run. The gas line installation must comply with local codes, or in their absence, with the latest edition of the National Fuel Gas Code, NFPA 54/ANSI Z223.1.

**Natural Gas Capacity of Pipe
In Cubic Feet of Gas Per Hour (CFH)**

Length of Pipe in Feet	Nominal Black Pipe Size				
	1/2"	3/4"	1"	1 1/4"	1 1/2"
10	132	278	520	1050	1600
20	92	190	350	730	1100
30	73	152	285	590	980
40	63	130	245	500	760
50	56	115	215	440	670
60	50	105	195	400	610
70	46	96	180	370	560
80	43	90	170	350	530
90	40	84	160	320	490
100	38	79	150	305	460

(Pressure 0.5 psig or less and pressure drop of 0.3" W.C.; Based on 0.60 Specific Gravity Gas)

$$\text{CFH} = \frac{\text{BTUH Furnace Input}}{\text{Heating Value of Gas (BTU/Cubic Foot)}}$$

To connect the furnace to the building's gas piping, the installer must supply a ground joint union, drip leg, manual shutoff valve, and line and fittings to connect to gas valve. In some cases, the installer may also need to supply a transition piece from 1/2" pipe to a larger pipe size.

The following stipulations apply when connecting gas piping. Refer to *Gas Piping Connections* figure for typical gas line connections to the furnace.

- Gas piping must be supported external to the furnace cabinet so that the weight of the gas line does not distort the burner rack, manifold or gas valve.
- Use black iron or steel pipe and fittings for building piping. Where possible, use new pipe that is properly chamfered, reamed, and free of burrs and chips. If old pipe is used, be sure it is clean and free of rust, scale, burrs, chips, and old pipe joint compound.
- Use pipe joint compound on male threads ONLY. Always use pipe joint compound (pipe dope) that is APPROVED FOR ALL GASES. DO NOT apply compound to the first two threads.
- Use ground joint unions.
- Install a drip leg to trap dirt and moisture before it can enter the gas valve. The drip leg must be a minimum of three inches long.
- Install a 1/8" NPT pipe plug fitting, accessible for test gage connection, immediately upstream of the gas supply connection to the furnace.
- Always use a back-up wrench when making the connection to the gas valve to keep it from turning. The orientation of the gas valve on the manifold must be maintained as shipped from the factory. Maximum torque for the gas valve connection is 375 in-lbs; excessive over-tightening may damage the gas valve.
- Install a manual shutoff valve between the gas meter and unit within six feet of the unit. If a union is installed, the union must be downstream of the manual shutoff valve, between the shutoff valve and the furnace.
- Tighten all joints securely.
- Connect the furnace to the building piping by one of the following methods:
 - Rigid metallic pipe and fittings.
 - Semi-rigid metallic tubing and metallic fittings. Aluminum alloy tubing must not be used in exterior locations. In order to seal the grommet cabinet penetration, rigid pipe must be used to reach the outside of the cabinet. A semi-rigid connector to the gas piping may be used from there.
- Use listed gas appliance connectors in accordance with their instructions. Connectors must be fully in the same room as the furnace.
- Protect connectors and semirigid tubing against physical and thermal damage when installed. Ensure aluminum-alloy tubing and connectors are coated to protect against external corrosion when in contact with masonry, plaster, or insulation, or subjected to repeated wetting by liquids such as water (except rain water), detergents, or sewage.

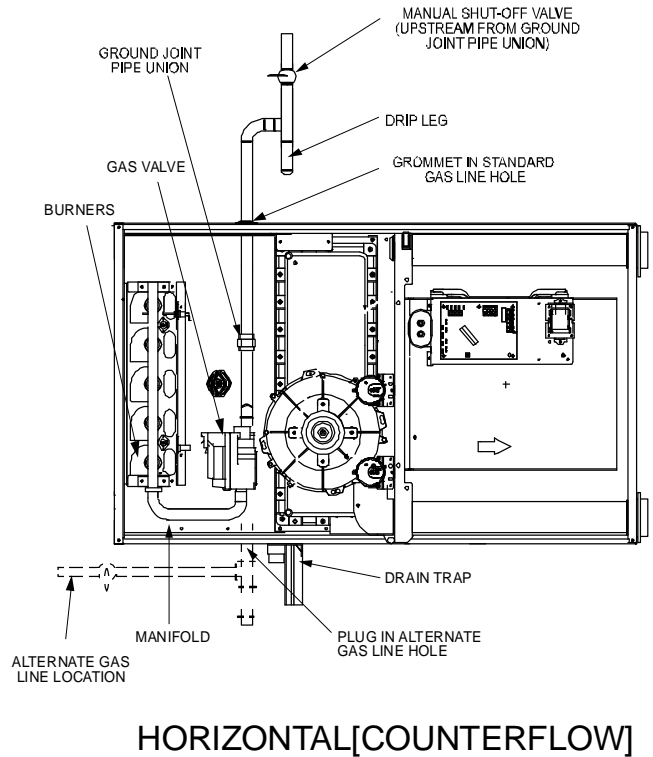
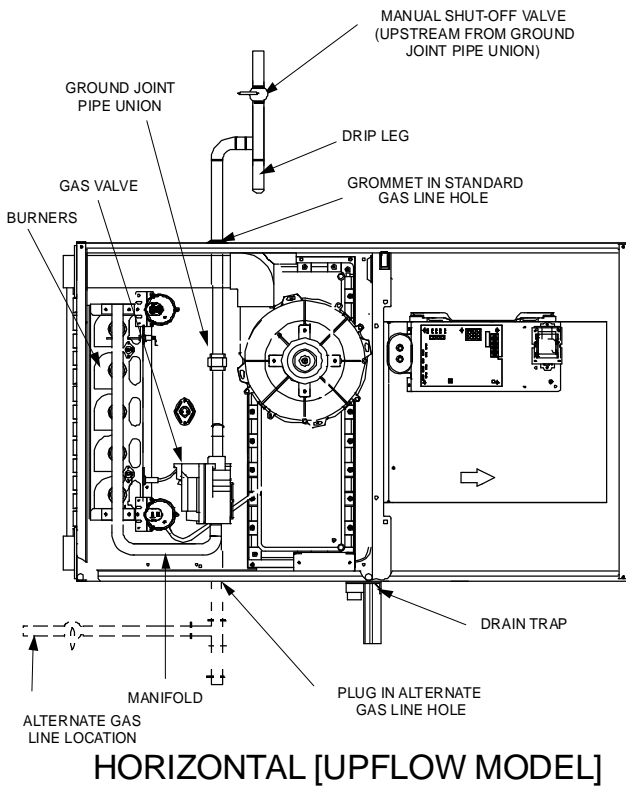
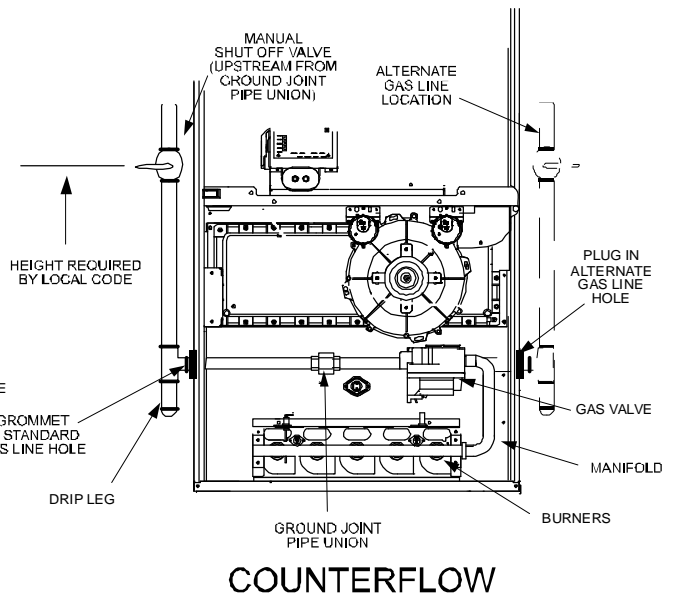
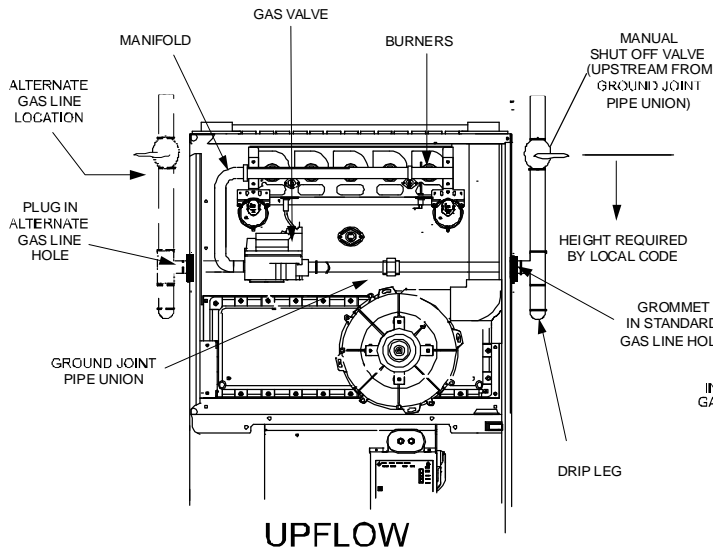

NOTES: 1. WHEN GAS LINE IS IN THE ALTERNATE LOCATION, SWAP THE POSITION OF THE PLUG AND GROMMET.

2. DRIP LEG MAY TERMINATE WITH A 1/2" X 1/8" PIPE PLUG TO ACCOMMODATE LINE GAS PRESSURE MEASUREMENT.

Gas Piping Connections

DIRECT/STANDARD INLET PIPING



WARNING

EDGES OF SHEET METAL HOLES MAY BE SHARP. USE GLOVES AS A PRECAUTION WHEN REMOVING HOLE PLUGS.

When gas piping enters *directly* to the gas valve through the *standard* inlet hole, the installer must supply straight pipe with a ground joint union to reach the exterior of the furnace. The rigid pipe must be long enough to reach the outside of the cabinet to seal the grommet cabinet penetration. A semi-rigid connector to the gas piping can be used outside the cabinet per local codes.

INDIRECT/ALTERNATE INLET PIPING

When gas piping enters *indirectly* to the gas valve through the *alternate* gas inlet hole the following fittings (starting from the gas valve) to reach the outside of the cabinet must be supplied:

- Close nipple.
- 90 degree elbow.
- 2½ inch nipple.
- 90 degree elbow.
- Straight pipe, with a ground joint union, to reach the exterior of the furnace. The rigid pipe must be long enough to reach the outside of the cabinet so as to seal the grommet cabinet penetration. A semi-rigid connector to the gas piping can be used outside the cabinet per local codes.

GAS PIPING CHECKS

Before placing unit in operation, leak test the unit and gas connections.



WARNING

TO AVOID THE POSSIBILITY OF EXPLOSION OR FIRE, NEVER USE A MATCH OR OPEN FLAME TO TEST FOR LEAKS.

Check for leaks using an approved chloride-free soap and water solution, an electronic combustible gas detector, or other approved testing methods.

NOTE: Never exceed specified pressures for testing. Higher pressure may damage the gas valve and cause subsequent overfiring, resulting in heat exchanger failure.

Disconnect this unit and shutoff valve from the gas supply piping system before pressure testing the supply piping system with pressures in excess of 1/2 psig (3.48 kPa).

Isolate this unit from the gas supply piping system by closing its external manual gas shutoff valve before pressure testing supply piping system with test pressures equal to or less than 1/2 psig (3.48 kPa).

PROPANE GAS TANKS AND PIPING



WARNING

IF THE GAS FURNACE IS INSTALLED IN A BASEMENT, AN EXCAVATED AREA OR CONFINED SPACE, IT IS STRONGLY RECOMMENDED TO CONTACT A PROPANE SUPPLIER TO INSTALL A GAS DETECTING WARNING DEVICE IN CASE OF A GAS LEAK.

- SINCE PROPANE GAS IS HEAVIER THAN AIR, ANY LEAKING GAS CAN SETTLE IN ANY LOW AREAS OR CONFINED SPACES.
- PROPANE GAS ODORANT MAY FADE, MAKING THE GAS UNDETECTABLE EXCEPT WITH A WARNING DEVICE.

A gas detecting warning system is the only reliable way to detect a propane gas leak. Rust can reduce the level of odorant in propane gas. Do not rely on your sense of smell. Contact a local propane gas supplier about installing a gas detecting warning system. If the presence of gas is suspected, follow the instructions listed in the *Safety Precautions* section of this manual.

All propane gas equipment must conform to the safety standards of the National Board of Fire Underwriters, NBFU Manual 58.

For satisfactory operation, propane gas pressure must be 10" WC \pm .5" WC at the furnace manifold with all gas appliances in operation. Maintaining proper gas pressure depends on three main factors:

1. Vaporization rate, depending on temperature of the liquid, and "wetted surface" area of the container or containers.
2. Proper pressure regulation. (Two-stage regulation is recommended for both cost and efficiency).
3. Pressure drop in lines between regulators, and between second stage regulator and the appliance. Pipe size will depend on length of pipe run and total load of all appliances.

Complete information regarding tank sizing for vaporization, recommended regulator settings, and pipe sizing is available from most regulator manufacturers and propane gas suppliers.

Since propane gas will quickly dissolve white lead and most standard commercial compounds, special pipe dope must be used. Shellac-based compounds resistant to the actions of liquefied petroleum gases such as Gasolac®, Stalactic®, Clyde's® or John Crane® are satisfactory.

Refer to the following illustration for typical propane gas installations and piping.

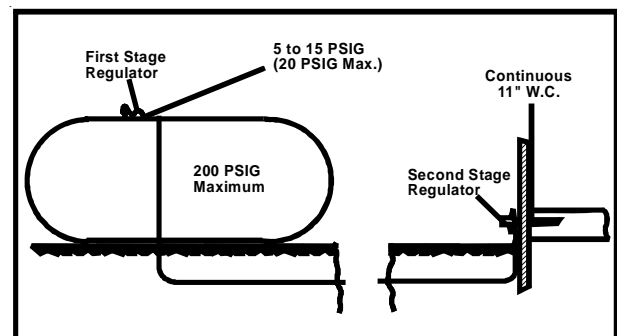

Propane Gas Installation (Typ.)

Sizing Between First and Second Stage Regulator*

Maximum Propane Capacities listed are based on 2 psig pressure drop at 10 psig setting. Capacities in 1,000 BTU/hour.

Pipe or Tubing Length Feet	Tubing Size, O.D. Type L					Nominal Pipe Size Schedule 40	
	3/8"	1/2"	5/8"	3/4"	7/8"	1/2"	3/4"
10	730	1,700	3,200	5,300	8,300	3,200	7,500
20	500	1,100	220	3,700	5,800	2,200	4,200
30	400	920	2,000	2,900	4,700	1,800	4,000
40	370	850	1,700	2,700	4,100	1,600	3,700
50	330	770	1,500	2,400	3,700	1,500	3,400
60	300	700	1,300	2,200	3,300	1,300	3,100
80	260	610	1,200	1,900	2,900	1,200	2,600
100	220	540	1,000	1,700	2,600	1,000	2,300
125	200	490	900	1,400	2,300	900	2,100
150	190	430	830	1,300	2,100	830	1,900
175	170	400	780	1,200	1,900	770	1,700
200	160	380	730	1,100	1,800	720	1,500

To convert to capacities at 15 psig settings - multiply by 1.130
 To convert to capacities at 5 psig settings - multiply by 0.879

Propane Gas Piping Chart I

Sizing Between Second or Second Stage Regulator & Appliance*

Maximum Propane Capacities listed are based on 1/2" W.C. pressure drop at 11" W.C. setting. Capacities in 1,000 BTU/hour.

Pipe or Tubing Length Feet	Tubing Size, O.D. Type L					Nominal Pipe Size Schedule 40				
	3/8"	1/2"	5/8"	3/4"	7/8"	1/2"	3/4"	1"	1-1/4"	1-1/2"
10	39	92	199	329	501	275	567	1,071	2,205	3,307
20	26	62	131	216	346	189	393	732	1,496	2,299
30	21	50	107	181	277	152	315	590	1,212	1,858
40	19	41	90	145	233	129	267	504	1,039	1,559
50	18	37	79	131	198	114	237	448	913	1,417
60	16	35	72	1,211	187	103	217	409	834	1,275
80	13	29	62	104	155	89	185	346	724	1,066
100	11	26	55	90	138	78	162	307	630	976
125	10	24	48	81	122	69	146	275	567	866
150	9	21	43	72	109	63	132	252	511	787
200	8	19	39	66	100	54	112	209	439	665
250	8	17	36	60	93	48	100	185	390	590

*Data in accordance with NFPA pamphlet No. 54

Propane Gas Piping Chart II

CIRCULATING AIR & FILTERS

DUCTWORK - AIR FLOW

 **WARNING**

NEVER ALLOW THE PRODUCTS OF COMBUSTION, INCLUDING CARBON MONOXIDE, TO ENTER THE RETURN DUCT WORK OR CIRCULATION AIR SUPPLY.

Duct systems and register sizes must be properly designed for the CFM and external static pressure rating of the furnace. Design the ductwork in accordance with the recommended methods of "Air Conditioning Contractors of America" Manual D.

Install the duct system in accordance with Standards of the National Board of Fire Underwriters for the Installation of Air Conditioning, Warm Air Heating and Ventilating Systems. Pamphlets No. 90A and 90B.

A closed return duct system must be used, with the return duct connected to the furnace. **NOTE: Ductwork must never be attached to the back of the furnace.** For upflow installations requiring 1800 CFM or more, use either two side returns or bottom return or a combination of side /bottom. Flexible joints may be used for supply and return connections to reduce noise transmission. To prevent the blower from interfering with combustion air or draft when a central return is used, a connecting duct must be installed between the unit and the utility room wall. Never use a room, closet, or alcove as a return air chamber.

CHECKING DUCT STATIC

Refer to your furnace rating plate for the maximum ESP (external duct static) rating.

Total external static refers to everything external to the furnace cabinet. Cooling coils, filters, ducts, grilles, registers must all be considered when reading your total external static pressure. The supply duct pressure must be read between the furnace and the cooling coil. This reading is usually taken by removing the "A" shaped block off plate from the end on the coil; drilling a test hole in it and reinstalling the block off plate. Take a duct static reading at the test hole. Tape up the test hole after your test is complete. The negative pressure must be read between the filter and the furnace blower.

Too much external static pressure will result in insufficient air that can cause excessive temperature rise. This can cause limit switch tripping and heat exchanger failure.

To determine total external duct static pressure, proceed as follows;

1. With clean filters in the furnace, use a draft gauge (inclined manometer) to measure the static pressure of the return duct at the inlet of the furnace. (Negative Pressure)
2. Measure the static pressure of the supply duct. (Positive Pressure)
3. The difference between the two numbers is .4" w.c.

Example:

static reading from return duct = -.1" w.c.

static reading from supply duct = .3" w.c.

total external static pressure on this system = .4" w.c.

NOTE: Both readings may be taken simultaneously and read directly on the manometer if so desired. If an air conditioner coil or Electronic Air Cleaner is used in conjunction with the furnace, the readings must also include these components, as shown in the following drawing.

4. Consult proper tables for the quantity of air.

If the total external static pressure exceeds the maximum listed on the furnace rating plate, check for closed dampers, registers, undersized and/or oversized poorly laid out duct work.

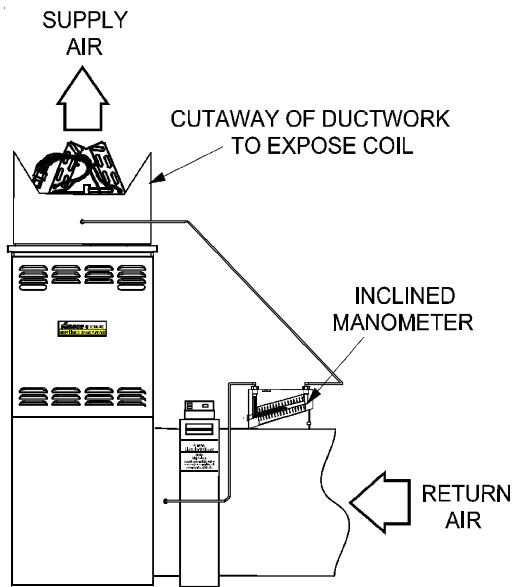

**Checking Static Pressure
(80% Furnace Shown, 90% Similar)**

BOTTOM RETURN AIR OPENING [UPFLOW MODELS]

The bottom return air opening on upflow models utilizes a “lance and cut” method to remove sheet metal from the duct opening in the base pan. To remove, simply press out the lanced sections by hand to expose the metal strips retaining the sheet metal over the duct opening. Using tin snips, cut the metal strips and remove the sheet metal covering the duct opening. In the corners of the opening, cut the sheet metal along the scribe lines to free the duct flanges. Using the scribe line along the duct flange as a guide, unfold the duct flanges around the perimeter of the opening using a pair of seamer pliers or seamer tongs. **NOTE:** Airflow area will be reduced by approximately 18% if duct flanges are not unfolded. This could cause performance issues and noise issues.

⚠ WARNING

EDGES OF SHEET METAL HOLES MAY BE SHARP. USE GLOVES AS A PRECAUTION WHEN REMOVING SHEET METAL FROM RETURN AIR OPENINGS.

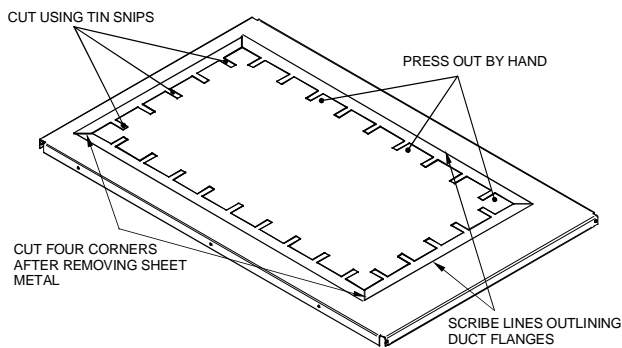

Duct Flange Cut Outs

When the furnace is used in connection with a cooling unit, the furnace should be installed in parallel with or on the upstream side of the cooling unit to avoid condensation in the heating element. With a parallel flow arrangement, the dampers or other means used to control the flow of air must be adequate to prevent chilled air from entering the furnace and, if manually operated, must be equipped with means to prevent operation of either unit unless the damper is in the full heat or cool position.

When the furnace is installed without a cooling coil, it is recommended that a removable access panel be provided in the outlet air duct. This opening shall be accessible when the furnace is installed and shall be of such a size that the heat exchanger can be viewed for visual light inspection or such that a sampling probe can be inserted into the airstream. The access panel must be made to prevent air leaks when the furnace is in operation.

When the furnace is heating, the temperature of the return air entering the furnace must be between 55°F and 100°F.

FILTERS - READ THIS SECTION BEFORE INSTALLING THE RETURN AIR DUCT WORK

Filters must be used with this furnace. Discuss filter maintenance with the building owner. Filters do not ship with this furnace, but must be provided, sized and installed externally by the installer. Filters must comply with UL900 or CAN/ULCS111 standards. If the furnace is installed without filters, the warranty will be voided.

On upflow units, guide dimples locate the side return cutout locations. Use a straight edge to scribe lines connecting the dimples. Cut out the opening on these lines. **NOTE:** An undersized opening will cause reduced airflow.

Refer to Minimum Filter Area tables to determine filter area requirements.

		UPFLOW COOLING AIRFLOW REQUIREMENT (CFM)						
		600	800	1000	1200	1400	1600	2000
Input Airflow	0603_XA	---	---	627*	627*	672	768	---
	0805_XA	---	---	---	836*	836*	836*	960
	1005_XA	---	---	---	940*	940*	940*	960
	1155_XA	---	---	---	---	---	---	---

		COUNTERFLOW COOLING AIRFLOW REQUIREMENT (CFM)						
		600	800	1000	1200	1400	1600	2000
Input Airflow	0604_XA	---	---	320*	320*	336	384	---
	0805_XA	---	---	---	427*	427*	427*	480
	1005_XA	---	---	---	---	---	---	---

*Minimum filter area dictated by heating airflow requirement.

Permanent Minimum Filter Area (sq. in)
[Based on a 600 ft/min filter face velocity]

		UPFLOW COOLING AIRFLOW REQUIREMENT (CFM)						
		600	800	1000	1200	1400	1600	2000
Input Airflow	0603__XA	---	---	564*	564*	672	768	
	0805__XA	---	---	---	752*	752*	768	960
	1005__XA	---	---	---	940*	940*	940*	960
	1155__XA	---	---	---	---	---	---	---

		COUNTERFLOW COOLING AIRFLOW REQUIREMENT (CFM)						
		600	800	1000	1200	1400	1600	2000
Input Airflow	0604__XA	---	---	641*	641*	672	768	---
	0805__XA	---	---	---	854*	854*	854*	960
	1005__XA	---	---	---	---	---	---	---
	---	---	---	---	---	---	---	---

*Minimum filter area dictated by heating airflow requirement.

Disposable Minimum Filter area (sq. in)
[Based on 300 ft/min filter face velocity]

UPRIGHT INSTALLATIONS

Depending on the installation and/or customer preference, differing filter arrangements can be applied. Filters can be installed in the central return register or a side panel external filter rack kit (upflows). As an alternative a media air filter or electronic air cleaner can be used as the requested filter.

The following figure shows possible filter locations.

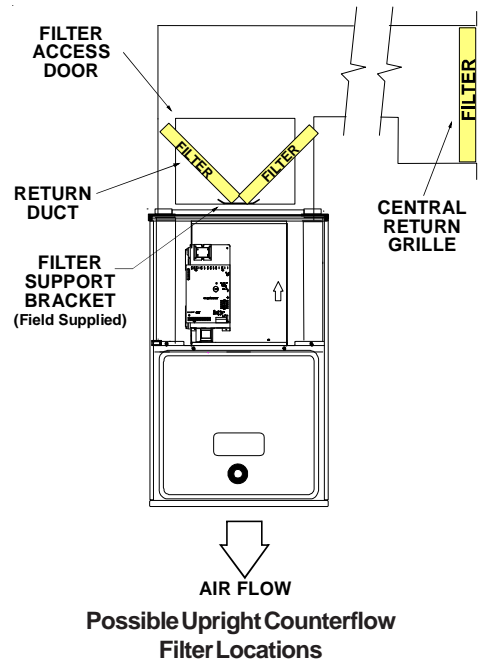
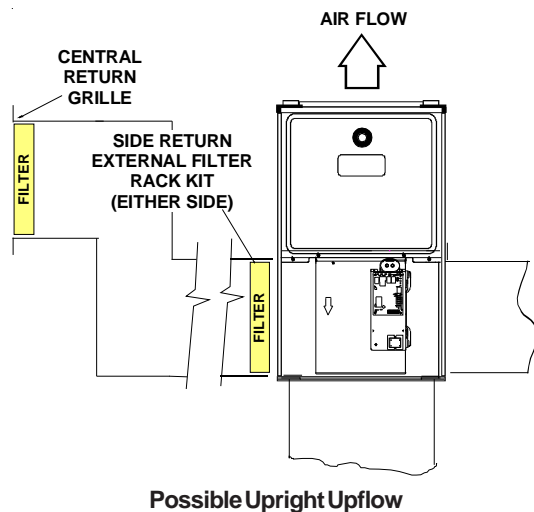

HORIZONTAL INSTALLATIONS

Filters must be installed in either the central return register or in the return air duct work.

STARTUP PROCEDURE & ADJUSTMENT

Furnace must have a 115 VAC power supply properly connected and grounded. Proper polarity must be maintained for correct operation. In addition to the following start-up and adjustment items, refer to further information in *Operational Checks* section.

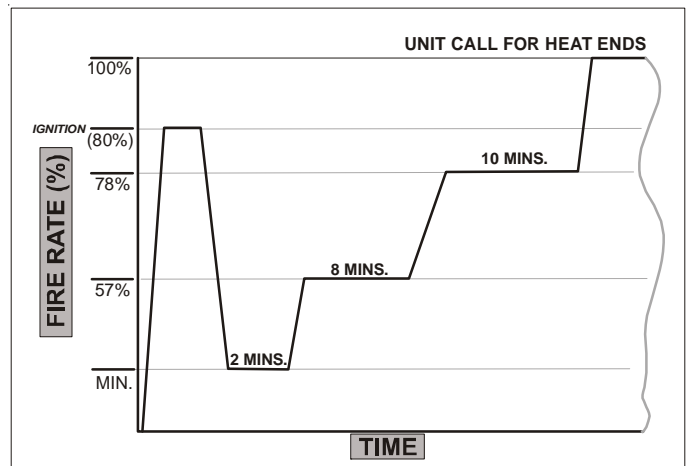

Operation with Conventional 1-Stage Thermostat
(DIP switch selections 1-Stage heat)

Call for heat, thermostat energizes W1 on IFC (W2 input is ignored).

After a successful Light Off Sequence and expiration of the Ignition Stabilization Period:

- After 2 minutes, the IFC increases to 57% at a rate of 1% per second
- After 10 total minutes, the IFC increases to 78% at a rate of 1% per second.
- After 20 total minutes, the IFC increases to 100% at a rate of 1% per second for the remainder of the call for heat.
- The circulator is adjusted to the appropriate CFM, corresponding to the current firing rate.

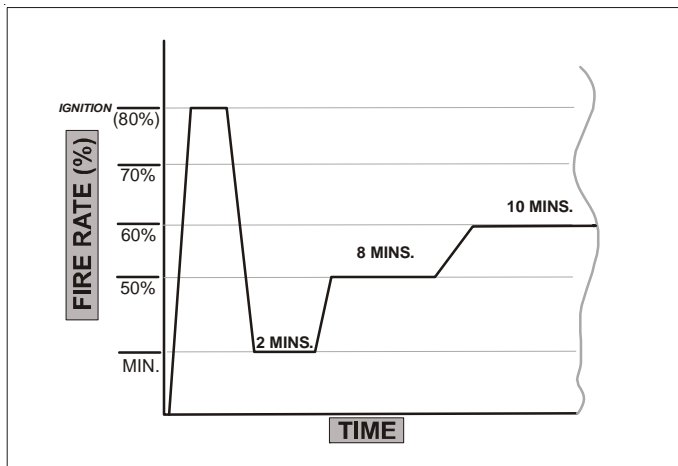

Operation with Conventional 2-Stage Thermostat (DIP switch selects 2-stage heat)

Call for 1st-Stage Heat - Thermostat contacts close R to W1.

After a successful Light Off Sequence and expiration of the Ignition Stabilization Period:

- The IFC adjusts to the low firing rate.
- After 2 minutes, the IFC increases to 50% for the next 8 minutes.
- Thereafter, the IFC will increase 10%, at a rate of 1% per second, every 10 minutes for the remainder of the call for heat (See above figure).
- The circulator is adjusted to the appropriate CFM, corresponding to the current firing rate.

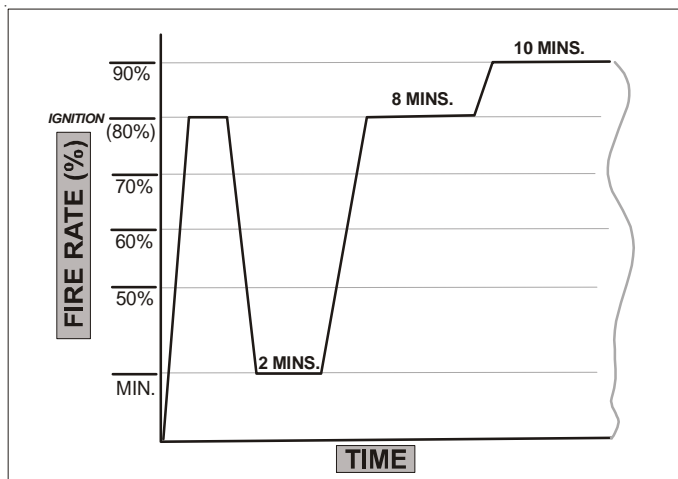

Operation with Conventional 2-Stage Thermostat (DIP switch selects 2-stage heat)

Call for 2nd-Stage Heat - Thermostat contacts close R to W1 and W2.

After a successful Light Off Sequence and expiration of the Ignition Stabilization Period:

- The IFC adjusts to the low firing rate.
- After 2 minutes, the IFC increases to 80%.
- Thereafter, the IFC will increase 10%, at a rate of 1% per second, every 10 minutes for the remainder of the call for heat.
- The circulator is adjusted to the appropriate CFM, corresponding to the current firing rate.

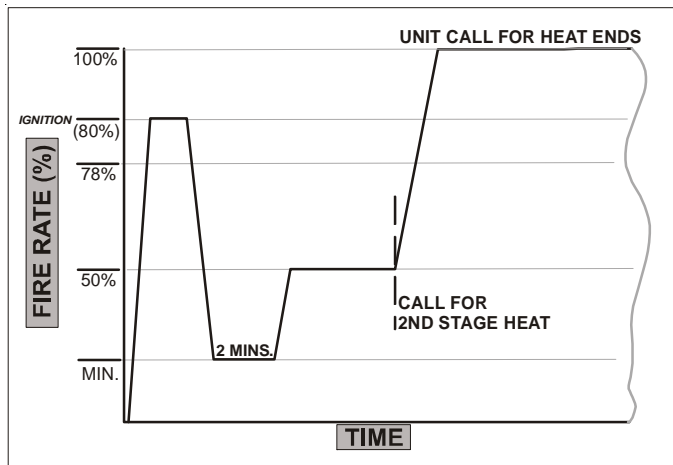

Call for 2nd-Stage Heat with 1st-Stage call for heat call in progress, with conventional 2-Stage Thermostat.

- The IFC increases the firing rate to 100% at a rate of 1% per second for the remainder of the W2 call.
- The circulator is adjusted to the appropriate CFM, corresponding to the current firing rate.

Call for 2nd-Stage Heat satisfied; Call for 1st-Stage Heat remains.

- The IFC remains at the current firing rate until the 1st-Stage call for heat is satisfied.

HEATING OPERATION WITH CTK01AA THERMOSTAT (COMMUNICATING)

- When the Thermostat Heat Setup DIP switch is set to 2-Stage heat, the IFC operation will be compatible with a CTK01AA communicating thermostat.
- When a call for heat is sent, the furnace will go through the Light Off Sequence, at which time the Heat Current Demand Status will still show 0%. After the successful Light Off Sequence and expiration of the Ignition Stabilization Period:
 - The IFC adjusts to the low firing rate.
 - After 2 minutes, the IFC accepts the specific Heat Requested Demand.

- If the differential is equal to or less than 2 degrees, the IFC will follow the conventional 2-Stage algorithm, equivalent to a W1 request and be reflected in the Heat Current Demand Status %.
- If the heat differential is greater than 2 degrees, the IFC will follow the conventional 2-Stage algorithm, equivalent to a W2 request and be reflected in the Heat Current Demand Status %.
- The circulator will operate per the heat airflow profile.

HEATING OPERATION WITH CTK02AA THERMOSTAT (MODULATING COMMUNICATING)

- When the Thermostat Heat Setup DIP switch is set to 1-Stage heat, the IFC operation will be compatible with a modulating communicating thermostat (CTK02AA).
- When a call for heat is sent, the furnace will go through the Light Off Sequence, at which time the Heat Current Demand Status will still show 0%. After the successful Light Off Sequence and expiration of the Ignition Stabilization Period:
 - The IFC adjusts to the low firing rate.
 - After 2 minutes, the IFC accepts the specific Heat Requested Demand.
 - If the differential is 2 degrees or less, the Heat Current Demand Status will show 50%.
 - If the specific Heat Requested Demand is above 2 degrees, the Heat Current Demand Status will track the specific Heat Requested Demand.
- The circulator will operate per the heat airflow profile.

HEAT ANTICIPATOR SETTING

The heat anticipator in the room thermostat must be correctly adjusted to obtain the proper number of cycles per hour and to prevent “overshooting” of the setting. Set the heat anticipator setting to 0.7 amps. Follow the thermostat manufacturer’s instructions on how to adjust the heat anticipator setting.

DRAIN TRAP PRIMING

The drain trap must be primed prior to furnace startup. To prime, fill the drain trap with water. This ensures proper furnace drainage upon startup and prohibits the possibility of flue gases escaping through the drain system. Air conditioning condensate may be drained into the furnace trap. Please see requirements in *Condensate Drain Lines & Drain Trap* section.

FURNACE OPERATION

Purge gas lines of air prior to startup. Be sure not to purge lines into an enclosed burner compartment.

Check for leaks using an approved chloride-free soap and water solution, an electronic combustible gas detector, or other approved method. Verify that all required kits (propane gas, etc.) have been appropriately installed.

FURNACE STARTUP

1. Close the manual gas shutoff valve external to the furnace.
2. Turn off the electrical power to the furnace.
3. Set the room thermostat to the lowest possible setting.
4. Remove the burner compartment door.

NOTE: This furnace is equipped with an ignition device which automatically lights the burner. Do not try to light the burner by hand.

5. Move the furnace gas valve manual control to the OFF position.
6. Wait five minutes then smell for gas. Be sure check near the floor as some types of gas are heavier than air.
7. If you smell gas after five minutes, immediately follow the *Safety Instructions* on page 5 of this manual. If you do not smell gas after five minutes, move the furnace gas valve manual control to the ON position.
8. Replace the burner compartment door.
9. Open the manual gas shutoff valve external to the furnace.
10. Turn on the electrical power to the furnace.
11. Adjust the thermostat to a setting above room temperature.
12. After the burners are lit, set the thermostat to desired temperature.

FURNACE SHUTDOWN

1. Set the thermostat to the lowest setting.

The integrated control will close the gas valve and extinguish flame. Following a 15 second delay, the induced draft blower will be de-energized. After a 120, 150, 180 or 210-second delay period (field selectable delay OFF [90, 120, 150, 180] plus 30-second ramp down), the circulator blower de-energizes.
2. Remove the burner compartment door and move the furnace gas valve manual control to the OFF position.
3. Close the manual gas shutoff valve external to the furnace.
4. Replace the burner compartment door.

GAS SUPPLY PRESSURE MEASUREMENT



TO PREVENT UNRELIABLE OPERATION OR EQUIPMENT DAMAGE, THE INLET GAS SUPPLY PRESSURE MUST BE AS SPECIFIED ON THE UNIT RATING PLATE WITH ALL OTHER HOUSEHOLD GAS FIRED APPLIANCES OPERATING.

The line pressure supplied to the gas valve must be within the range specified below. The supply pressure can be measured at the gas valve inlet pressure boss or at a hose fitting installed in the gas piping drip leg. The supply pressure must be measured with the burners operating. To measure the gas supply pressure, use the following procedure.

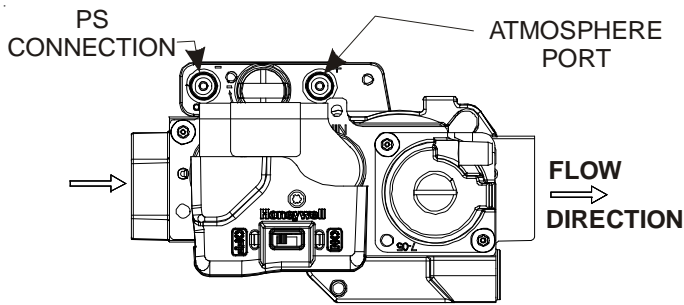

Honeywell Model VR9205R

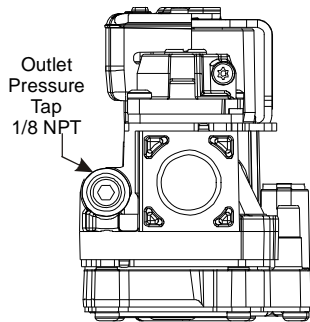
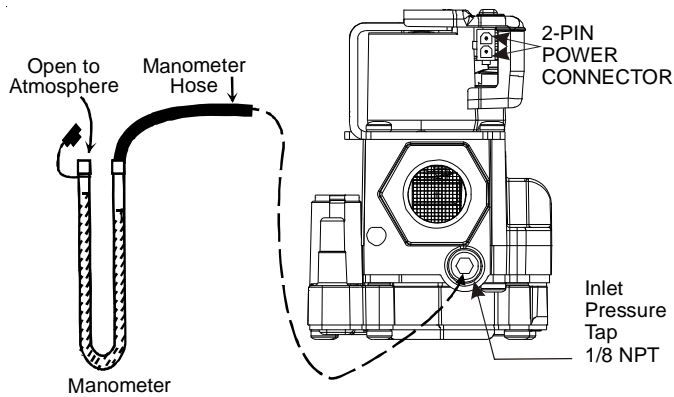

Honeywell Model VR9205R Connected to Manometer

1. Turn OFF gas to furnace at the manual gas shutoff valve external to the furnace.
2. Connect a calibrated water manometer (or appropriate gas pressure gauge) at either the gas valve inlet pressure boss or the gas piping drip leg. See Honeywell VR9205R gas valve figure for location of inlet pressure boss.

NOTE: If measuring gas pressure at the drip leg or Honeywell VR9205R gas valve, a field-supplied hose barb fitting must be installed prior to making the hose connection.

3. Turn ON the gas supply and operate the furnace and all other gas consuming appliances on the same gas supply line.

Field Test Mode is intended to help a service person troubleshoot and check out an installed appliance.

To enter Field Test Mode the Fault Recall Push-Button must be pressed twice within a 5 second period at any time during a heating cycle, at which time the display will show "Ft". While the display is showing "Ft", pressing and holding the Fault Recall Push-Button for 3 seconds will enable the field test mode and override

the normal firing rate sequence at a rate of 100% for 5 minutes or until the end of the call for heat. The display will show the normal "Hi" while the control is firing at 100%. If the Fault Recall Push-Button has not been pressed within 5 seconds of displaying "Ft" the display will revert back to normal.

4. Measure furnace gas supply pressure with burners firing. Supply pressure must be within the range specified in the *Inlet Gas Supply Pressure* table.

Inlet Gas Supply Pressure		
Natural Gas	Minimum: 5.0" w.c.	Maximum: 10.0" w.c.
Propane Gas	Minimum: 11.0" w.c.	Maximum: 13.0" w.c.

If supply pressure differs from table, make the necessary adjustments to pressure regulator, gas piping size, etc., and/or consult with local gas utility.

5. Turn OFF gas to furnace at the manual shutoff valve and disconnect manometer. Reinstall plug before turning on gas to furnace.
6. Turn OFF any unnecessary gas appliances stated in step 3.

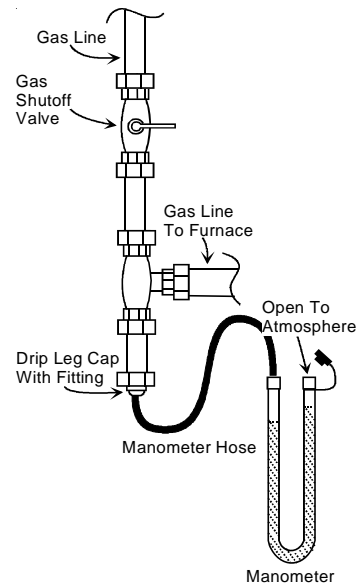

Measuring Inlet Gas Pressure (Alt. Method)

GAS MANIFOLD PRESSURE MEASUREMENT

CAUTION

TO PREVENT UNRELIABLE OPERATION OR EQUIPMENT DAMAGE, THE GAS MANIFOLD PRESSURE MUST BE AS SPECIFIED ON THE UNIT RATING PLATE. GAS VALVE IS FACTORY SET AND DOES NOT REQUIRE ANY FIELD ADJUSTMENT. DO NOT ATTEMPT TO ADJUST VALVE.

The manifold pressure must be measured with the burners operating. To measure the manifold pressure, use the following procedure.

1. Turn OFF gas to furnace at the manual gas shutoff valve external to the furnace.
2. Turn off all electrical power to the system.

3. Outlet pressure tap connections: Remove the outlet pressure boss plug. Install an 1/8" NPT hose barb fitting into the outlet pressure tap.
4. Attach a hose and manometer to the outlet pressure barb fitting.
5. Turn ON the gas supply.
6. Turn on power and close thermostat "R" and "W1" contacts to provide a call for low stage heat.

NOTE: After every time the main power is turned off and back on, the furnace will enter a calibration routine on the next call for heat. *The inducer will ramp up and down during the calibration routine. After calibration, the furnace will proceed to ignition cycle.*

7. Field Test Mode is intended to help a service person troubleshoot and check out an installed appliance.

To enter Field Test Mode the Fault Recall Push-Button must be pressed twice within a 5 second period at any time during a heating cycle, at which time the display will show "Ft". While the display is showing "Ft", pressing and holding the Fault Recall Push-Button for 3 seconds will enable the field test mode and override the normal firing rate sequence at a rate of 100% for 5 minutes or until the end of the call for heat. The display will show the normal "Hi" while the control is firing at 100%. If the Fault Recall Push-Button has not been pressed within 5 seconds of displaying "Ft" the display will revert back to normal.

NOTE: Gas valve is factory set and does NOT require any field adjustment. Do NOT attempt to adjust valve.

Measure the gas manifold pressure with burners firing.

8. Turn off all electrical power and gas supply to the system.
9. Remove the manometer hose from the hose barb fitting.
10. Remove the 1/8" NPT hose barb fitting from the outlet pressure tap. Replace the outlet pressure boss plug and seal with a high quality thread sealer.
11. Turn on electrical power and gas supply to the system.
12. Close thermostat contacts "R" and "W1/W2" to energize the valve.

Using a leak detection solution or soap suds, check for leaks at outlet pressure boss plug. Bubbles forming indicate a leak. SHUT OFF GAS AND REPAIR ALL LEAKS IMMEDIATELY!

NOTE: For natural gas to LP conversion, consult the furnace Specification Sheet.

Manifold Gas Pressure			
Gas		Range	Nominal
Natural	High Stage	3.2 - 3.8" w.c.	3.5" w.c.
Propane	High Stage	9.5 - 10.5" w.c.	10.0" w.c.

GAS INPUT RATE MEASUREMENT (NATURAL GAS ONLY)

The gas input rate to the furnace must never be greater than that specified on the unit rating plate. To measure natural gas input using the gas meter, use the following procedure.

1. Turn OFF the gas supply to all other gas-burning appliances except the furnace.
2. While the furnace is operating, time and record one complete revolution of the smallest gas meter dial.
3. Calculate the number of seconds per cubic foot (sec/ft³) of gas being delivered to the furnace. If the dial is a one cubic foot dial, divide the number of seconds recorded in step 2 by one. If the dial is a two cubic foot dial, divide the number of seconds recorded in step 2 by two.
4. Calculate the furnace input in BTUs per hour (BTU/hr). Input equals the sum of the installation's gas heating value and a conversion factor (hours to seconds) divided by the number of seconds per cubic foot. The measured input must not be greater than the input indicated on the unit rating plate.

EXAMPLE:

Installation's gas heating (HTG) value: 1,000 BTU/ft³
(Obtained from gas supplier)

Installation's seconds per cubic foot: 34 sec/ ft³

Conversion Factor (hours to seconds): 3600 sec/hr

Input = (Htg. value x 3600) ÷ seconds per cubic foot

Input = (1,000 BTU/ft³ x 3600 sec/hr) ÷ 34 sec/ ft³

Input = 106,000 BTU/hr

NOTE: The final manifold pressure cannot vary by more than ± 0.3" w.c. for Natural and ± 0.5" for LP from the specified setting. Consult your local gas supplier if additional input rate adjustment is required.

5. Turn ON gas to and relight all other appliances turned off in step 1. Be certain that all appliances are functioning properly and that all pilot burners are operating.

TEMPERATURE RISE

Temperature rise must be within the range specified on the unit rating plate. An incorrect temperature rise may result in condensing in or overheating of the heat exchanger. An airflow and temperature rise table is provided in the Specification Sheet applicable to your model. Determine and adjust temperature rise as follows:

1. Operate furnace with burners firing for approximately ten minutes. Ensure all registers are open and all duct dampers are in their final (fully or partially open) position.
2. Place thermometers in the return and supply ducts as close to the furnace as possible. Thermometers must not be influenced by radiant heat by being able to "see" the heat exchanger.
3. Subtract the return air temperature from the supply air temperature to determine the air temperature rise. Allow adequate time for thermometer readings to stabilize.

- Adjust temperature rise by adjusting the circulator blower speed. Increase blower speed to reduce temperature rise. Decrease blower speed to increase temperature rise. Refer to *Startup Procedure and Adjustment -Circulator Blower Speeds* for speed changing details.

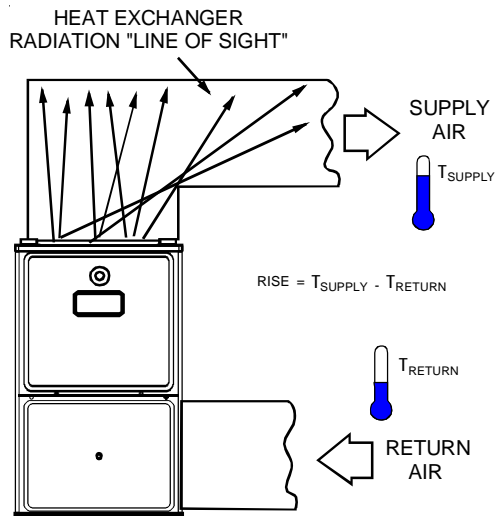

Temperature Rise Measurement

CIRCULATOR BLOWER SPEEDS



WARNING

TO AVOID PERSONAL INJURY OR DEATH DUE TO ELECTRICAL SHOCK, TURN OFF POWER TO THE FURNACE BEFORE CHANGING SPEED TAPS.

This furnace is equipped with a multi-speed circulator blower. This blower provides ease in adjusting blower speeds. The heating blower speed is shipped set at "B", and the cooling blower speed is set at "D". These blower speeds should be adjusted by the installer to match the installation requirements so as to provide the correct heating temperature rise and correct cooling CFM.

Use the dual 7-segment LED display adjacent to the dipswitches to obtain the approximate airflow quantity. The airflow quantity is displayed as a number on the display, rounded to the nearest 100 CFM. The display alternates airflow delivery indication and the operating mode indication.

Example: The airflow being delivered is 1225 CFM. The display indicates 12. If the airflow being delivered is 1275, the display indicates 13.

- Determine the tonnage of the cooling system installed with the furnace. If the cooling capacity is in BTU/hr divide it by 12,000 to convert capacity to TONS.

Example: Cooling Capacity of 30,000 BTU/hr.

$$30,000/12,000 = 2.5 \text{ Tons}$$

- Determine the proper air flow for the cooling system. Most cooling systems are designed to work with air flows between 350 and 450 CFM per ton. Most manufacturers recommend an air flow of about 400 CFM per ton.

Example: 2.5 tons X 400 CFM per ton = 1000 CFM

The cooling system manufacturer's instructions must be checked for required air flow. Any electronic air cleaners or other devices may require specific air flows, consult installation instructions of those devices for requirements.

- Knowing the furnace model, locate the high stage cooling air flow charts in the Specification Sheet applicable to your model. Look up the cooling air flow determined in step 2 and find the required cooling speed and adjustment setting.

Example: A *MVM960603BX furnace installed with a 2.5 ton air conditioning system. The air flow needed is 1000 CFM. Looking at the cooling speed chart for *MVM960603BX, find the air flow closest to 1000 CFM. A cooling airflow of 1000 CFM can be attained by selecting the cooling speed "C" and the adjustment to "normal".

- Continuous fan speed is selectable at 25%, 50%, 75% or 100% of the furnace's maximum airflow capability.

Example: If the furnace's maximum airflow capability is 2000 CFM, the continuous fan speed will be 0.25 x 2000 or 500 CFM.

- Locate the blower speed selection DIP switches on the integrated control module. Select the desired "cooling" speed tap by positioning switches 1 and 2 appropriately. Select the desired "adjust" tap by positioning switches 9 and 10 appropriately. Refer to the dip switch chart for switch positions and their corresponding taps. Verify CFM by noting the number displayed on the dual 7-segment LED display.
- The multi-speed circulator blower also offers several custom ON/OFF ramping profiles. These profiles may be used to enhance cooling performance and increase comfort level. The ramping profiles are selected using DIP switches 7 and 8. Refer to the following figure for switch positions and their corresponding taps. Refer to the bullet points below for a description of each ramping profile. Verify CFM by noting the number displayed on the dual 7-segment LED display.

- **Profile A** provides only an OFF delay of one (1) minute at 100% of the cooling demand airflow.

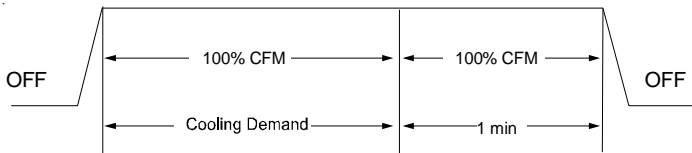

- **Profile B** ramps up to full cooling demand airflow by first stepping up to 50% of the full demand for 30 seconds. The motor then ramps to 100% of the required airflow. A one (1) minute OFF delay at 100% of the cooling airflow is provided.

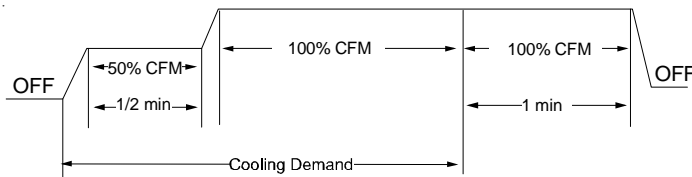

- **Profile C** ramps up to 85% of the full cooling demand airflow and operates there for approximately 7 1/2 minutes. The motor then steps up to the full demand airflow. Profile C also has a one (1) minute 100% OFF delay.

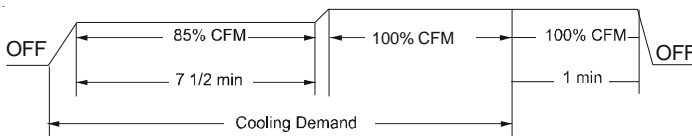

- **Profile D** ramps up to 50% of the demand for 1/2 minute, then ramps to 85% of the full cooling demand airflow and operates there for approximately 7 1/2 minutes. The motor then steps up to the full demand airflow. Profile D has a 1/2 minute at 50% airflow OFF delay.

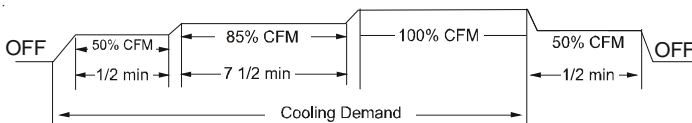

Model	Tap	Low Stage Cool	High Stage Cool	Low Stage Heat	High Stage Heat
CVM960604CX	A	370	660	880	1220
	B	540	860	970	1340
	C	790	1150	1040	1460
	D	980	1470	1120	1590
CVM960805DX	A	530	900	1110	1600
	B	730	1100	1200	1710
	C	930	1430	1270	1800
	D	1220	1880	1330	1910
GCVM961005DX*	A	500	780	1220	1730
	B	740	1070	1250	1770
	C	920	1380	1300	1840
	D	1160	1780	1310	1870
MVM960603BX	A	390	630	600	820
	B	550	800	650	890
	C	680	1000	690	950
	D	800	1210	730	1030
MVM960805CX	A	540	830	1140	1600
	B	750	1090	1190	1690
	C	980	1460	1270	1800
	D	1210	1800	1330	1890
MVM961005DX	A	510	790	1230	1810
	B	710	1100	1260	1850
	C	910	1410	1300	1890
	D	1160	1830	1330	1940
MVM961155DX	A	510	790	1230	1810
	B	710	1100	1260	1850
	C	910	1410	1300	1890
	D	1160	1830	1330	1940

Airflow Table

7. Select the heating speed for your model from the heating speed chart in the Specification Sheet. The “adjust” setting (already established by the cooling speed selection) determines which set of speeds are available. The selected speed must provide a temperature rise within the rise range listed with the particular model.
8. Select the desired “heating” speed tap by positioning switches 3 and 4 appropriately. Refer to figure above. Verify CFM by noting the number displayed on the dual 7-segment LED display.

In general lower heating speeds will: reduce electrical consumption, lower operating sound levels of the blower, and increase the outlet air temperature delivered to the home. The speeds available allow the blower performance to be optimized for the particular homeowner’s needs.

BLOWER HEAT OFF DELAY TIMINGS

The integrated control module provides a selectable heat off delay function. The heat off delay period may be set to 90, 120, 150, 180 seconds using the DIP switches or jumper provided on the control module. The delay is factory shipped at 150 seconds but may be changed to suit the installation requirements and/or homeowner preference. Refer to the dip switch chart in the back section of this manual for switch positions and corresponding delay times.

COMFORTNET™ SYSTEM

OVERVIEW

NOTE: Dip switch #13 **MUST** be set to match thermostat type. To use the CTK01AA communicating thermostat, dip switch #13 must be set to ON position. This is also the correct setting for a non-communicating 2-stage thermostat. To use the CTK02AA modulating thermostat, check to make sure dip switch #13 is in the OFF position (factory position). This is also the correct position when using a non-communicating single stage thermostat.

The ComfortNet system is a system that includes a ComfortNet compatible furnace and air conditioner or heat pump with a CTK0*AA thermostat. A valid ComfortNet system could also be a compatible furnace, CTK0*AA thermostat and non-compatible, single stage air conditioner. Any other system configurations are considered invalid ComfortNet systems and must be connected as a traditional (or non-communicating) system (see *Electrical Connections* for wiring connections).

A ComfortNet heating/air conditioning system differs from a non-communicating/traditional system in the manner in which the indoor unit, outdoor unit and thermostat interact with one another. In a traditional system, the thermostat sends commands to the indoor and outdoor units via analog 24 VAC signals. It is a one-way communication path in that the indoor and outdoor units typically do not return information to the thermostat.

The indoor unit, outdoor unit and thermostat comprising a ComfortNet system “communicate” digitally with one another, creating a two-way communications path. The thermostat still sends commands to the indoor and outdoor units. However, the thermostat may also request and receive information from both the indoor and outdoor units. This information may be displayed on the ComfortNet thermostat. The indoor and outdoor units also interact with one another. The outdoor unit may send commands to or request information from the indoor unit. This two-way digital communications between the thermostat and subsystems (indoor/outdoor unit) and between subsystems is the key to unlocking the benefits and features of the ComfortNet system.

Two-way digital communications is accomplished using only two wires. The thermostat and subsystem controls are powered with 24 VAC. Thus, a maximum of 4 wires between the equipment and thermostat is all that is required to operate the system.

AIRFLOW CONSIDERATIONS

Airflow demands are managed differently in a fully communicating system than they are in a non-communicating wired system. The system operating mode (as determined by the thermostat) determines which unit calculates the system airflow demand. If the indoor unit is responsible for determining the airflow demand, it calculates the demand and sends it to the ECM motor. If the outdoor unit or thermostat is responsible for determining the demand, it calculates the demand and transmits the demand along with a fan request to the indoor unit. The indoor unit then sends the demand to the ECM motor. The table below lists the various ComfortNet systems, the operating mode, and airflow demand source.

System	System Operating Mode	Airflow Demand Source
Air Conditioner + Furnace	Cooling	Air Conditioner
	Heating	Furnace
	Continuous Fan	Thermostat
Heat Pump + Furnace	Cooling	Heat Pump
	Heat Pump Heating Only	Heat Pump
	Auxiliary Heating	Furnace
	Continuous Fan	Thermostat
Furnace + Non-Comm 1stg Air Conditioner	Cooling	Furnace
	Heating	Furnace
	Continuous Fan	Thermostat

For example, assume the system is an air conditioner matched with a furnace. With a call for low stage cooling, the air conditioner will calculate the system's low stage cooling airflow demand. The air conditioner will then send a fan request along with the low stage cooling airflow demand to the furnace. Once received, the furnace will send the low stage cooling airflow demand to the ECM motor. The ECM motor then delivers the low stage cooling airflow. See the applicable ComfortNet air conditioner or heat pump installation manual for the airflow delivered during cooling or heat pump heating.

In continuous fan mode, the CTK0*AA thermostat provides the airflow demand. The thermostat may be configured for one of three continuous fan speed settings allow for 25%, 50% or 75% airflow, based on the furnaces' maximum airflow capability. During continuous fan operation, the thermostat sends a fan request along with the continuous fan demand to the furnace. The furnace, in turn, sends the demand to the ECM motor. The ECM motor delivers the requested continuous fan airflow.

DIP SWITCHES

Switch Bank	Purpose	Function	Dip Switch																	
			1	2	3	4	5	6	7	8	9	10	11	12	13	14	15	16	17	18
1	Cooling Speed Tap	A	OFF	OFF	---	---	---	---	---	---	---	---	---	---	---	---	---	---	---	---
		B	ON	OFF	---	---	---	---	---	---	---	---	---	---	---	---	---	---	---	---
		C	OFF	ON	---	---	---	---	---	---	---	---	---	---	---	---	---	---	---	---
		D	ON	ON	---	---	---	---	---	---	---	---	---	---	---	---	---	---	---	---
	Heating Speed Tap	A	---	---	OFF	OFF	---	---	---	---	---	---	---	---	---	---	---	---	---	---
		B	---	---	ON	OFF	---	---	---	---	---	---	---	---	---	---	---	---	---	---
		C	---	---	OFF	ON	---	---	---	---	---	---	---	---	---	---	---	---	---	---
		D	---	---	ON	ON	---	---	---	---	---	---	---	---	---	---	---	---	---	---
	Continuous Fan Speed Tap	A	---	---	---	---	OFF	OFF	---	---	---	---	---	---	---	---	---	---	---	---
		B	---	---	---	---	ON	OFF	---	---	---	---	---	---	---	---	---	---	---	---
		C	---	---	---	---	OFF	ON	---	---	---	---	---	---	---	---	---	---	---	---
		D	---	---	---	---	ON	ON	---	---	---	---	---	---	---	---	---	---	---	---
	Cooling Ramping	A	---	---	---	---	---	---	OFF	OFF	---	---	---	---	---	---	---	---	---	---
		B	---	---	---	---	---	---	ON	OFF	---	---	---	---	---	---	---	---	---	---
		C	---	---	---	---	---	---	OFF	ON	---	---	---	---	---	---	---	---	---	---
		D	---	---	---	---	---	---	ON	ON	---	---	---	---	---	---	---	---	---	---
2	Adjust Taps	0 Trim Adjust	---	---	---	---	---	---	---	---	---	---	---	---	---	---	---	---	---	---
		Plus 10%	---	---	---	---	---	---	---	---	---	OFF	OFF	---	---	---	---	---	---	---
		Minus 10%	---	---	---	---	---	---	---	---	---	OFF	ON	---	---	---	---	---	---	---
		0 Trim Adjust	---	---	---	---	---	---	---	---	---	ON	ON	---	---	---	---	---	---	---
	Heat Off Delay	90 Seconds	---	---	---	---	---	---	---	---	---	---	---	---	---	---	---	---	---	---
		120 Seconds	---	---	---	---	---	---	---	---	---	---	---	---	---	---	---	---	---	---
		150 Seconds	---	---	---	---	---	---	---	---	---	---	---	---	---	---	---	---	---	---
		180 Seconds	---	---	---	---	---	---	---	---	---	---	---	---	---	---	---	---	---	---
	T-Stat Heat	1 Stage Stat	---	---	---	---	---	---	---	---	---	---	---	---	---	---	---	---	---	---
		2 Stage Stat	---	---	---	---	---	---	---	---	---	---	---	---	---	---	---	---	---	---
	Compressor	1-Stage Compressor	---	---	---	---	---	---	---	---	---	---	---	---	---	---	---	---	---	---
		2-Stage Compressor	---	---	---	---	---	---	---	---	---	---	---	---	---	---	---	---	---	---
Dehum	Disabled	---	---	---	---	---	---	---	---	---	---	---	---	---	---	---	---	---	---	
	Enabled	---	---	---	---	---	---	---	---	---	---	---	---	---	---	---	---	---	---	
Bias	Disabled	---	---	---	---	---	---	---	---	---	---	---	---	---	---	---	---	---	---	
	Enabled	---	---	---	---	---	---	---	---	---	---	---	---	---	---	---	---	---	---	
Pull Up	Disabled	---	---	---	---	---	---	---	---	---	---	---	---	---	---	---	---	---	---	
	Enabled	---	---	---	---	---	---	---	---	---	---	---	---	---	---	---	---	---	---	
Pull Down	Disabled	---	---	---	---	---	---	---	---	---	---	---	---	---	---	---	---	---	---	
	Enabled	---	---	---	---	---	---	---	---	---	---	---	---	---	---	---	---	---	---	
3	Compressor	1-Stage Compressor	---	---	---	---	---	---	---	---	---	---	---	---	---	---	---	---	---	---
		2-Stage Compressor	---	---	---	---	---	---	---	---	---	---	---	---	---	---	---	---	---	---
		Disabled	---	---	---	---	---	---	---	---	---	---	---	---	---	---	---	---	---	---
		Enabled	---	---	---	---	---	---	---	---	---	---	---	---	---	---	---	---	---	---
	Bias	Disabled	---	---	---	---	---	---	---	---	---	---	---	---	---	---	---	---	---	---
		Enabled	---	---	---	---	---	---	---	---	---	---	---	---	---	---	---	---	---	---
		Disabled	---	---	---	---	---	---	---	---	---	---	---	---	---	---	---	---	---	---
		Enabled	---	---	---	---	---	---	---	---	---	---	---	---	---	---	---	---	---	---
	Pull Up	Disabled	---	---	---	---	---	---	---	---	---	---	---	---	---	---	---	---	---	---
		Enabled	---	---	---	---	---	---	---	---	---	---	---	---	---	---	---	---	---	---
		Disabled	---	---	---	---	---	---	---	---	---	---	---	---	---	---	---	---	---	---
		Enabled	---	---	---	---	---	---	---	---	---	---	---	---	---	---	---	---	---	---
	Pull Down	Disabled	---	---	---	---	---	---	---	---	---	---	---	---	---	---	---	---	---	---
		Enabled	---	---	---	---	---	---	---	---	---	---	---	---	---	---	---	---	---	---
		Disabled	---	---	---	---	---	---	---	---	---	---	---	---	---	---	---	---	---	---
		Enabled	---	---	---	---	---	---	---	---	---	---	---	---	---	---	---	---	---	---

--- Not applicable
 (Indicates factory setting)
 Communicating thermostats are used only with Bias, Pull Up, Pull Down dip switches.

FOSSIL FUEL APPLICATIONS

This furnace can be used in conjunction with a ComfortNet™ compatible heat pump in a fossil fuel application. A fossil fuel application refers to a combined gas furnace and heat pump installation which uses an outdoor temperature sensor to determine the most cost efficient means of heating (heat pump or gas furnace). When used with the CTK0*AA thermostat, the furnace/heat pump system is automatically configured as a fossil fuel system. The balance point temperature may be adjusted via the CTK0*AA thermostat advanced user menus (see CTK0*AA instructions for additional information).

CTK0*AA WIRING

NOTE: Refer to *Electrical Connections* for 115 volt line connections to the furnace.

NOTE: A removable plug connector is provided with the control to make thermostat wire connections. This plug may be removed, wire connections made to the plug, and replaced. It is **strongly** recommended that multiple wires into a single terminal be twisted together prior to inserting into the plug connector. Failure to do so may result in intermittent operation.

Typical 18 AWG thermostat wire may be used to wire the system components. One hundred (100) feet is the maximum length of wire between indoor unit and outdoor unit, or between indoor unit and thermostat. Wire runs over (100) feet require larger gauge wire.

FOUR-WIRE INDOOR AND OUTDOOR WIRING

Typical ComfortNet wiring will consist of four wires between the indoor unit and outdoor unit and between the indoor unit and thermostat. The required wires are: (a) data lines, 1 and 2; (b) thermostat “R” (24 VAC hot) and “C” (24 VAC common).

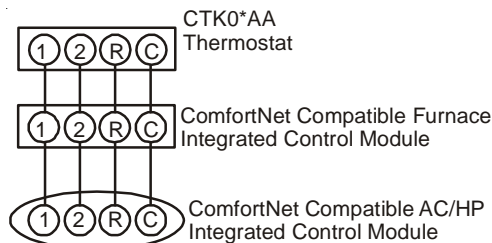

System Wiring using Four-Wires

TWO-WIRE OUTDOOR, FOUR-WIRE INDOOR WIRING

Two wires can be utilized between the indoor and outdoor units. For this wiring scheme, only the data lines, 1 and 2, are needed between the indoor and outdoor units. A 40VA, 208/230 VAC to 24VAC transformer must be installed in the outdoor unit to provide 24VAC power to the outdoor unit's electronic control. The transformer is included with the CTK0*AA kit. See kit instructions for mounting and wiring instructions. Four wires are required between the indoor unit and thermostat.

NOTE: Use of the CTK0*AA transformer is recommended if installing a dual fuel/fossil fuel system. Failure to use the transformer in the outdoor unit could result in over loading of the furnace transformer.

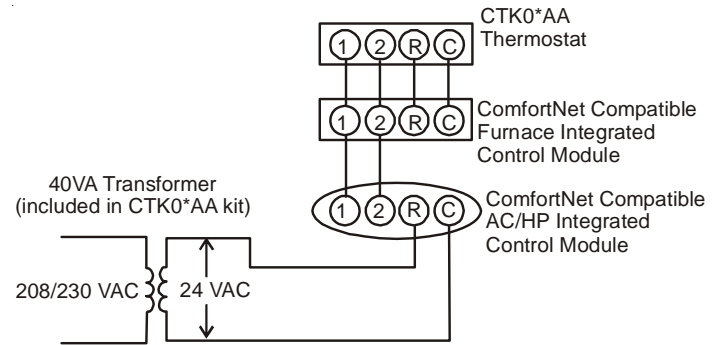

System Wiring using Two-Wires between Furnace and AC/HP and Four-Wires between Furnace and Thermostat

COMFORTNET COMPATIBLE FURNACE WITH NON-COMFORTNET COMPATIBLE SINGLE-STAGE AIR CONDITIONER

Four wires are required between the furnace and thermostat. Two wires are required between the furnace control and single stage air conditioner. For this system configuration, the “Y1” terminal on the integrated furnace control becomes an output rather than an input. The “Y1” connection to the outdoor unit is made using both 4-position thermostat connectors in the CTK0*AA kit. Remove the red keying tabs from the on-board connector block and position both 4-position connector such that “1”, “2”, “R”, “C”, and “Y1” positions are filled.

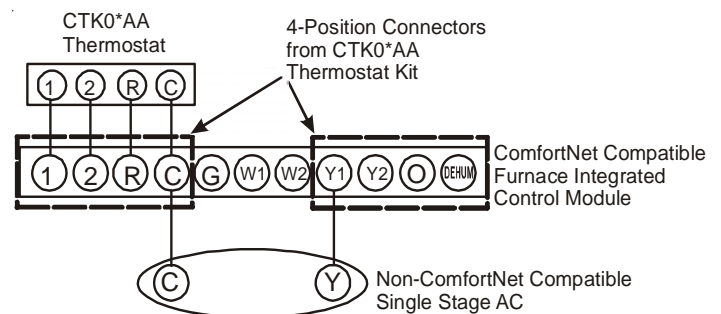

System Wiring between Furnace and Non-Communicating Compatible Single Stage Air Conditioner

COMFORTNET™ SYSTEM ADVANCED FEATURES

The ComfortNet system permits access to additional system information, advanced setup features, and advanced diagnostic/troubleshooting features. These advanced features are organized into a menu structure. The menus are accessed and navigated as described in the instructions provided with the CTK0*AA communicating control.

FURNACE ADVANCED FEATURES MENUS

CONFIGURATION	
Submenu Item	Indication (for Display Only; not User Modifiable)
Number of Heat Stages (HT STG)	Displays the number of furnace heating stages
Input Rate (BTU/HR)	Displays the furnace input rate in kBtu/hr
Motor HP (1/2, 3/4, or 1 MTR HP)	Displays the furnace indoor blower motor horsepower

DIAGNOSTICS		
Submenu Item	Indication/User Modifiable Options	Comments
Fault 1 (FAULT #1)	Most recent furnace fault	For display only
Fault 2 (FAULT #2)	Next most recent furnace fault	For display only
Fault 3 (FAULT #3)	Next most recent furnace fault	For display only
Fault 4 (FAULT #4)	Next most recent furnace fault	For display only
Fault 5 (FAULT #5)	Next most recent furnace fault	For display only
Fault 6 (FAULT #6)	Least recent furnace fault	For display only
Clear Fault History (CLEAR)	NO or YES	Selecting "YES" clears the fault history

NOTE: Consecutively repeated faults are shown a maximum of 3 times.

IDENTIFICATION	
Submenu Item	Indication (for Display Only; not User Modifiable)
Model Number (MOD NUM)	Displays the furnace model number
Serial Number (SER NUM)	Displays the furnace serial number (Optional)
Software (SOFTWARE)	Displays the application software revision

SET-UP		
Submenu Item	User Modifiable Options	Comments
Heat Airflow Trim (HT TRM)	-15% to +15% in 3% increments, default is 0%	Trims the heating airflow by the selected amount.
Heat ON Delay (HT ON)	5, 10, 15, 20, 25, or 30 seconds, default is 30 seconds	Selects the indoor blower heat ON delay
Heat OFF Delay (HT OFF)	30, 60, 90, 120, 150, or 180 seconds, default is 150 seconds	Selects the indoor blower heat OFF delay
Heat Airflow (HT ADJ)	1, 2, 3, or 4	Selects the nominal heating airflow (see Section XIV, <i>Startup Procedure and Adjustment – Circulator Blower Speeds</i> for addition information)

STATUS	
Submenu Item	Indication (for Display Only; not User Modifiable)
Mode (MODE)	Displays the current furnace operating mode
CFM (CFM)	Displays the airflow for the current operating mode

NON-COMM (APPLIES ONLY TO A COMMUNICATING COMPATIBLE FURNACE MATCHED WITH A NON-COMMUNICATING COMPATIBLE SINGLE STAGE AIR CONDITIONER)		
Submenu Item	User Modifiable Options	Comments
Cool Airflow (CL CFM)	18, 24, 30, 36, 42, 48, or 60, default is 18	Selects the airflow for the non-communicating compatible single stage AC unit
Cool Airflow Trim (CL TRM)	-10% to +10% in 2% increments, default is 0%	Selects the airflow trim amount for the non-communicating compatible single stage AC unit
Cool Airflow Profile (CL PRFL)	A, B, C, or D, default is A	Selects the airflow profile for the non-communicating compatible single stage AC unit
Cool ON Delay (CL ON)	5, 10, 20, or 30 seconds, default is 5 seconds	Selects the indoor blower ON delay for the non-communicating compatible single stage AC unit
Cool OFF Delay (CL OFF)	30, 60, 90, or 120 seconds, default is 30 seconds	Selects the indoor blower OFF delay for the non-communicating compatible single stage AC unit

THERMOSTAT MENU

If this furnace is installed with a communicating compatible heat pump, the system is recognized as a dual fuel system. The balance point temperature should be set via the thermostat advanced menu. Navigate to the **THERMOSTAT** menu. Press the **INSTALLER CONFIG** key. Navigate to the **SETUP** menu and press the **INSTALLER CONFIG** button. See *communicating thermostat installation instructions for additional information*. Navigate to **dF BAL PNT**. Adjust the dual fuel system balance point using the back/forward arrows.

DIAGNOSTICS

Accessing the furnace's diagnostics menu provides ready access to the last ten faults detected by the furnace. Faults are stored most recent to least recent. Any consecutively repeated fault is stored a maximum of three times. Example: A clogged return air filter causes the furnace limit to trip repeatedly. The control will only store this fault the first three *consecutive* times the fault occurs. Navigate to the diagnostics menu as described above in *Accessing and Navigating the Advanced Features Menus*.

NOTE: It is highly recommended that the fault history be cleared when performing maintenance or servicing the furnace.

NETWORK TROUBLESHOOTING

The indoor control is equipped with a bank of three dipswitches that provide biasing and termination functions for the communications transmission lines. The outdoor control in the communicating compatible unit is equipped with a bank of two dipswitches that provide termination functions for the communications transmission lines. Communications errors will result if these switches are not correctly set. Note that the ON position is the correct position for all bias and pull up/pull down dipswitches.

The ComfortNet™ system is a fully communicating system, and thus, constitutes a network. Occasionally the need to troubleshoot the network may arise. The integrated furnace control has some on-board tools that may be used to troubleshoot the network. These tools are: red communications LED, green receive (Rx) LED, and learn button.

- Red communications LED – Indicates the status of the network. The table below indicates the LED status and the corresponding potential problem.
- Green receive LED – Indicates network traffic. The table below indicates the LED status and the corresponding potential problem.
- Learn button – Used to reset the network. Depress the button for approximately 2 seconds to reset the network.

SYSTEM TROUBLESHOOTING

NOTE: Refer to the instructions accompanying the ComfortNet compatible outdoor AC/HP unit for troubleshooting information.

Refer to the *Troubleshooting Codes* for a listing of possible furnace error codes, possible causes and corrective actions.

FAULT RECALL SEQUENCE

- Only allowed in standby mode while display is showing ON.
- Hold fault recall push-button for 2-5 seconds (until display is blank) and then release.
- Display will then be blank for 2 seconds before displaying faults stored in history.
- All faults are displayed one time, from most recent to least recent.
- A Maximum of 3 consecutive faults of the same type will be logged.
- Each error is displayed for 2 seconds, with a blank screen for 1 second in between.
- When all errors have been displayed, the display returns to ON.

LED	LED Status	Indication	Possible Causes	Corrective Action(s)	Notes & Cautions
Red Communications LED	Off	• Normal condition	• None	• None	• None
	1 Flash	• Communications Failure	• Communications Failure	• Depress Learn Button • Verify that pull up, pull down and bias dip switches are in the ON position.	• Depress once quickly for a power-up reset • Depress and hold for 2 seconds for an out-of-box reset.
	2 Flashes	• Out-of-box reset	• Control power up • Learn button depressed	• None	• None
Green Receive LED	Rapid Flashing	• Normal network traffic	• Control is "talking" on network as expected	• None	• None
	On Solid	• Data 1/ Data 2 miss-wire	• Data 1 and data 2 wires reversed at furnace, thermostat or communicating compatible outdoor AC/HP • Short between data 1 and data 2 wires. • Short between data 1 or data 2 wires and R (24VAC) or C (24VAC common).	• Check communications wiring (data 1/ data 2 wires). • Check wire connections at terminal block • Check data 1/ data 2 voltages.	• Turn power OFF prior to repair. • Verify wires at terminal blocks are securely twisted together prior to inserting into terminal block. • Verify data 1 and data voltages as described above

FAULT CLEAR SEQUENCE:

- Only allowed in standby mode, while display is showing ON.
- Hold fault recall push-button for 5-10 seconds (until display starts flashing "—") and then release.
- All faults in the history will have been cleared, and display returns to ON.
- If you hold the button for longer than 10 seconds, the display will return to ON and the faults will not be cleared.

NORMAL SEQUENCE OF OPERATION

POWER UP

The normal power up sequence is as follows:

- 115 VAC power applied to furnace.
- Integrated control module performs internal checks.
- Integrated control module monitors safety circuits continuously.
- Furnace awaits call from thermostat. Dual 7-segment LED's display 0π while awaiting call from thermostat.

HEATING MODE

The normal operational sequence in heating mode is as follows:

- Thermostat contacts close, initiating a call for heat.
- Integrated control module performs safety circuit checks.
- Induced draft blower is energized on high speed for a 15-second prepurge.
- Induced draft blower steps to low speed following prepurge. Low stage pressure switch contacts are closed.
- Igniter warm up begins upon step to low speed and presence of closed low stage pressure switch contacts.

- Gas valve opens at end of igniter warm up period, delivering gas to burners and establishing flame.
- Integrated control module monitors flame presence. Gas valve will remain open only if flame is detected.
- The percentage of heating demand is sent from the IFC to determine what RPM the draft inducer should run at. A higher percentage demand will drive the inducer RPM higher. This will cause the gas valve to modulate higher. The burner will modulate based on the inducer speed
- Circulator blower is energized on heat speed following a thirty (30) second blower on delay. The circulator blower CFM will increase or decrease with gas valve modulation. Electronic air cleaner terminal is energized with circulator blower.
- Furnace is now operating on the specified stage called for by the thermostat.
- Furnace runs, integrated control module monitors safety circuits continuously.
- If the two-stage thermostat changes the call from low heat to high heat, the integrated control module will immediately switch the induced draft blower, gas valve, and circulator blower to their high stage settings.
- The thermostat contacts open, completing the call for heat.
- Gas valve closes, extinguishing flame.
- Induced draft blower is de-energized following a fifteen second post purge. Humidifier contacts open.
- Circulator blower continues running for the selected heat off delay period (90, 120, 150 or 180 seconds). The speed run during this period depends on the last heat call provided by the thermostat.

If the last call for heat was a call for high heat, the air circulating motor will run on the high heating speed for thirty (30) seconds and then switch to the low heating speed for the **balance** of the heat off delay period (60, 90, 120 or 150 seconds).

- Circulator blower and electronic air cleaner terminal is de-energized.
- Circulator blower ramps down to OFF during the 30 seconds following the heat off delay period.
- Furnace awaits next call from thermostat.

COOLING MODE

The normal operational sequence in cooling mode is as follows:

- R and Y1/G or Y2/G thermostat contacts close, initiating a call for cool.
- Integrated control module performs safety circuit checks.
- Outdoor fan and compressor are energized to their appropriate speed.
- Circulator blower is energized on the appropriate cool speed at the level and time determined by the selected ramping profile. Electronic air cleaner terminal is energized with circulator blower.
- Furnace circulator blower and outdoor cooling unit run their appropriate speeds, integrated control module monitors safety circuits continuously.
- R and Y1/G or Y2/G thermostat contacts open, completing the call for cool.
- Outdoor fan and compressor are de-energized.
- Circulator blower continues running during a cool off delay period. The OFF delay time and airflow level are determined by the selected ramping profile.
- Electronic air cleaner terminal and circulator blower are de-energized.
- Furnace awaits next call from thermostat.

FAN ONLY MODE

The normal operational sequence in fan only mode is as follows:

- R and G thermostat contacts close, initiating a call for fan.
- Integrated control module performs safety circuit checks.
- Circulator blower is energized on continuous fan speed (25%, 50%, 75% or 100% dip switch selectable when using a conventional thermostat). Electronic air cleaner terminal is energized.
- The IFC HUM dry contacts close.
- Circulator blower runs, integrated control module monitors safety circuits continuously.
- R and G thermostat contacts open, completing the call for fan.
- Circulator blower is de-energized. Electronic air cleaner terminal is de-energized.
- Furnace awaits next call from thermostat.

OPERATIONAL CHECKS

The burner flames should be inspected with the burner compartment door installed. Flames should be stable, quiet, soft, and blue (dust may cause orange tips but they must not be yellow). Flames should extend directly outward from the burners without curling, floating, or lifting off. Flames must not impinge on the sides of the heat exchanger firing tubes.

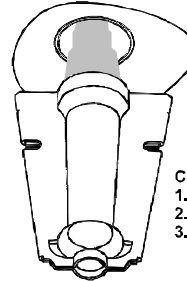

Check the burner flames for:
1. Good adjustment
2. Stable, soft and blue
3. Not curling, floating, or lifting off.

Burner Flame

SAFETY CIRCUIT DESCRIPTION

A number of safety circuits are employed to ensure safe and proper furnace operation. These circuits serve to control any potential safety hazards and serve as inputs in the monitoring and diagnosis of abnormal function. These circuits are continuously monitored during furnace operation by the integrated control module.

INTEGRATED FURNACE CONTROL (IFC)

The integrated control module is an electronic device which, if a potential safety concern is detected, will take the necessary precautions and provide diagnostic information through an LED display.

PRIMARY LIMIT

The primary limit control is located on the partition panel and monitors heat exchanger compartment temperatures. It is a normally-closed (electrically), automatic reset, temperature-activated sensor. The limit guards against overheating as a result of insufficient conditioned air passing over the heat exchanger.

AUXILIARY LIMIT

The auxiliary limit controls are located on or near the circulator blower and monitors blower compartment temperatures. They are a normally-closed (electrically), auto-reset sensors. These limits guard against overheating as a result of insufficient conditioned air passing over the heat exchanger.

ROLLOUT LIMIT

The rollout limit controls are mounted on the burner/manifold assembly and monitor the burner flame. They are normally-closed (electrically), manual-reset sensors. These limits guard against burner flames not being properly drawn into the heat exchanger.

PRESSURE SWITCHES

The pressure switches are normally-open (closed during operation) negative air pressure-activated switches. They monitor the airflow (combustion air and flue products) through the heat exchanger via pressure taps located on the induced draft blower and the coil front cover. These switches guard against insufficient airflow (combustion air and flue products) through the heat exchanger and/or blocked condensate drain conditions.

FLAME SENSOR

The flame sensor is a probe mounted to the burner/manifold assembly which uses the principle of flame rectification to determine the presence or absence of flame.

TROUBLESHOOTING

ELECTROSTATIC DISCHARGE (ESD) PRECAUTIONS

NOTE: Discharge body's static electricity before touching unit. An electrostatic discharge can adversely affect electrical components.

Use the following precautions during furnace installation and servicing to protect the integrated control module from damage. By putting the furnace, the control, and the person at the same electrostatic potential, these steps will help avoid exposing the integrated control module to electrostatic discharge. This procedure is applicable to both installed and uninstalled (ungrounded) furnaces.

1. Disconnect all power to the furnace. Do not touch the integrated control module or any wire connected to the control prior to discharging your body's electrostatic charge to ground.
2. Firmly touch a clean, unpainted, metal surface of the furnace away from the control. Any tools held in a person's hand during grounding will be discharged.
3. Service integrated control module or connecting wiring following the discharge process in step 2. Use caution not to recharge your body with static electricity; (i.e., do not move or shuffle your feet, do not touch ungrounded objects, etc.). If you come in contact with an ungrounded object, repeat step 2 before touching control or wires.
4. Discharge your body to ground before removing a new control from its container. Follow steps 1 through 3 if installing the control on a furnace. Return any old or new controls to their containers before touching any ungrounded object.

DIAGNOSTIC CHART

 **WARNING**

HIGH VOLTAGE !

TO AVOID PERSONAL INJURY OR DEATH DUE TO ELECTRICAL SHOCK, DISCONNECT ELECTRICAL POWER BEFORE PERFORMING ANY SERVICE OR MAINTENANCE.



Refer to the *Troubleshooting Codes* for assistance in determining the source of unit operational problems. The dual 7-segment LED display will display an error code that may contain a letter and number. The error code may be used to assist in troubleshooting the unit.

RESETTING FROM LOCKOUT

Furnace lockout results when a furnace is unable to achieve ignition after three attempts during a single call for heat. It is characterized by a non-functioning furnace and a **E0** code displayed on the dual 7-segment display. If the furnace is in "lockout", it will (or can be) reset in any of the following ways.

1. Automatic reset. The integrated control module will automatically reset itself and attempt to resume normal operations following a one hour lockout period.
2. Manual power interruption. Interrupt 115 volt power to the furnace.
3. Manual thermostat cycle. Lower the thermostat so that there is no longer a call for heat for 1 -20 seconds then reset to previous setting.

NOTE: If the condition which originally caused the lockout still exists, the control will return to lockout. Refer to the *Troubleshooting Codes* for aid in determining the cause.

MAINTENANCE

 **WARNING**

TO AVOID ELECTRICAL SHOCK, INJURY OR DEATH, DISCONNECT ELECTRICAL POWER BEFORE PERFORMING ANY MAINTENANCE. IF YOU MUST HANDLE THE IGNITER, HANDLE WITH CARE. TOUCHING THE IGNITER ELEMENT WITH BARE FINGERS, ROUGH HANDLING OR VIBRATION COULD DAMAGE THE IGNITER RESULTING IN PREMATURE FAILURE. ONLY A QUALIFIED SERVICER SHOULD EVER HANDLE THE IGNITER.



ANNUAL INSPECTION

The furnace should be inspected by a qualified installer, or service agency at least once per year. This check should be performed at the beginning of the heating season. This will ensure that all furnace components are in proper working order and that the heating system functions appropriately. Pay particular attention to the following items. Repair or service as necessary.

- Flue pipe system. Check for blockage and/or leakage. Check the outside termination and the connections at and internal to the furnace.
- Heat exchanger. Check for corrosion and/or buildup within the heat exchanger passageways.
- Burners. Check for proper ignition, burner flame, and flame sense.
- Drainage system. Check for blockage and/or leakage. Check hose connections at and internal to furnace.
- Wiring. Check electrical connections for tightness and/or corrosion. Check wires for damage.
- Filters.

FILTERS



CAUTION

TO ENSURE PROPER UNIT PERFORMANCE, ADHERE TO THE FILTER SIZES GIVEN IN THE RECOMMENDED MINIMUM FILTER SIZE TABLE OR SPECIFICATION SHEET APPLICABLE TO YOUR MODEL.

FILTER MAINTENANCE

Improper filter maintenance is the most common cause of inadequate heating or cooling performance. Filters should be cleaned (permanent) or replaced (disposable) every two months or as required. When replacing a filter, it must be replaced with a filter of the same type and size.

FILTER REMOVAL

Depending on the installation, differing filter arrangements can be applied. Filters can be installed in either the central return register or a side panel external filter rack (upflow only). A media air filter or electronic air cleaner can be used as an alternate filter. Follow the filter sizes given in the Recommended Minimum Filter size table to ensure proper unit performance.

To remove filters from an external filter rack in an upright upflow installation, follow the directions provided with external filter rack kit.

HORIZONTAL UNIT FILTER REMOVAL

Filters in horizontal installations are located in the central return register or the ductwork near the furnace.

To remove:

1. Turn OFF electrical power to furnace.
2. Remove filter(s) from the central return register or ductwork.
3. Replace filter(s) by reversing the procedure for removal.
4. Turn ON electrical power to furnace.

MEDIA AIR FILTER OR ELECTRONIC AIR CLEANER REMOVAL

Follow the manufacturer's directions for service.

BURNERS

Visually inspect the burner flames periodically during the heating season. Turn on the furnace at the thermostat and allow several minutes for flames to stabilize, since any dislodged dust will alter the flames normal appearance. Flames should be stable, quiet, soft, and blue (dust may cause orange tips but they must not be yellow). They should extend directly outward from the burners without curling, floating, or lifting off. Flames must not impinge on the sides of the heat exchanger firing tubes.

INDUCED DRAFT AND CIRCULATOR BLOWERS

The bearings in the induced draft blower and circulator blower motors are permanently lubricated by the manufacturer. No further lubrication is required. Check motor windings for accumulation of dust which may cause overheating. Clean as necessary.

CONDENSATE TRAP AND DRAIN SYSTEM (QUALIFIED SERVICER ONLY)

Annually inspect the drain tubes, drain trap, and field-supplied drain line for proper condensate drainage. Check drain system for hose connection tightness, blockage, and leaks. Clean or repair as necessary.

FLAME SENSOR (QUALIFIED SERVICER ONLY)

Under some conditions, the fuel or air supply can create a nearly invisible coating on the flame sensor. This coating acts as an insulator causing a drop in the flame sense signal. If the flame sense signal drops too low the furnace will not sense flame and will lock out. The flame sensor should be carefully cleaned by a qualified servicer using emery cloth or steel wool. Following cleaning, the flame sense signal should be as indicated in the Specifications Sheet.

BEFORE LEAVING AN INSTALLATION

- Cycle the furnace with the thermostat at least three times. Verify cooling and fan only operation.
- Review the Owner's Manual with the homeowner and discuss proper furnace operation and maintenance.
- Leave literature packet near furnace.

REPAIR AND REPLACEMENT PARTS

- When ordering any of the listed functional parts, be sure to provide the furnace model, manufacturing, and serial numbers with the order.
- Although only functional parts are shown in the parts list, all sheet metal parts, doors, etc. may be ordered by description.
- Parts are available from your distributor.

Functional Parts List-

Gas Valve
Gas Manifold
Natural Gas Orifice
Propane Gas Orifice
Igniter
Flame Sensor
Rollout Limit Switch
Primary Limit Switch
Auxiliary Limit Switch
Pressure Switch
Induced Draft Blower
Door Switch

Blower Motor
Blower Wheel
Blower Mounting Bracket
Blower Cutoff
Blower Housing
Inductor
Heat Exchanger with
Recuperator Coil
Coil Front Cover
Integrated Control Module
Transformer

TROUBLESHOOTING CODES

Symptoms of Abnormal Operation (Non-communicating & ComfortNet™ Thermostat)	Diagnostic/Status LED Codes		Fault Description		ComfortNet Thermostat Only Message Code		Possible Causes	Corrective Actions	Notes & Cautions
	IF	IF	No 115 power to furnace or no 24 volt power to integrated control module	INTERNAL FAULT	EE	Manual disconnect switch OFF, door switch open or 24 volt wire improperly connected or loose			
<ul style="list-style-type: none"> Furnace fails to operate Integrated control module LED display provides no signal. ComfortNet thermostat "Call for Service" icon illuminated ComfortNet thermostat scrolls "Check Furnace" message 	IF	No 115 power to furnace or no 24 volt power to integrated control module	INTERNAL FAULT	EE	<ul style="list-style-type: none"> Manual disconnect switch OFF, door switch open or 24 volt wire improperly connected or loose Blown fuse or circuit breaker Integrated control module has an internal fault 	<ul style="list-style-type: none"> Assure 115 and 24 volt power to furnace and integrated control module. Check integrated control module fuse (3A). Replace if necessary. Correct polarity of line voltage wires. Check for possible shorts in 115 and 24 volt circuits. Repair as necessary. Replace bad integrated control module. 	<ul style="list-style-type: none"> Turn power OFF prior to repair. Replace integrated control module fuse with 3A automotive fuse. Read precautions in "Electrostatic Discharge" section of manual. Replace integrated control module with current replacement parts. 		
<ul style="list-style-type: none"> LED display indicates Dn 	□n	Normal operation	None	None	Normal operation	<ul style="list-style-type: none"> Normal operation 	<ul style="list-style-type: none"> None 	<ul style="list-style-type: none"> Normal operation 	
<ul style="list-style-type: none"> Furnace fails to operate Integrated control module LED display provides E0 error code. ComfortNet thermostat "Call for Service" icon illuminated. ComfortNet thermostat scrolls "Check Furnace" message. 	E0	Furnace lockout due to an excessive number of ignition "retries" (3 total)	LOCKOUT	E0	<ul style="list-style-type: none"> Failure to establish flame. Cause may be no gas to burners, front cover pressure switch stuck open, bad igniter or igniter alignment, improper orifices, or coated/oxidized or improperly connected flame sensor. Loss of flame after establishment. Cause may be interrupted gas supply, lazy burner flames (improper gas pressure or restriction in flue and/or combustion air piping), front cover pressure switch opening, or improper induced draft blower performance. 	<ul style="list-style-type: none"> Locate and correct gas interruption. Check front cover pressure switch operation (hose, wiring, contact operation). Correct if necessary. Make sure furnace is draining properly. Replace or realign igniter. Check flame sense signal. Sand sensor if coated and/or oxidized. Check flue piping for blockage, proper length, elbows, and termination. Verify proper induced draft blower performance. 	<ul style="list-style-type: none"> Turn power OFF prior to repair. Igniter is fragile, handle with care. Clean flame rod with steel wool. See "Vent/Flue Pipe" section for piping details. 		
<ul style="list-style-type: none"> Furnace fails to operate. Integrated control module LED display provides E1 error code. ComfortNet thermostat "Call for Service" icon illuminated. ComfortNet thermostat scrolls "Check Furnace" message. 	E1	Low stage pressure switch circuit is closed at start of heating cycle.	PSI CLOSED	E1	<ul style="list-style-type: none"> Low stage pressure switch contacts sticking. Shorts in pressure switch circuit wiring. 	<ul style="list-style-type: none"> Replace low stage pressure switch. Repair short in wiring. 	<ul style="list-style-type: none"> Turn power OFF prior to repair. Replace pressure switch with correct replacement part. 		
<ul style="list-style-type: none"> Induced draft blower runs continuously with no further furnace operation. Integrated control module LED display provides E2 error code. ComfortNet thermostat "Call for Service" icon illuminated. ComfortNet thermostat scrolls "Check Furnace" message. 	E2	Low stage pressure switch circuit is not closed.	PSI OPEN	E2	<ul style="list-style-type: none"> Pressure switch hose blocked pinched, or connected improperly. Blocked flue and/or inlet air pipe, blocked drain system or weak induced draft blower. Incorrect pressure switch set point or malfunctioning switch contacts. Loose or improperly connected wiring. Inducer not running. H fitting atmospheric port blocked. 	<ul style="list-style-type: none"> Inspect pressure switch hose. Repair/replace if necessary. Inspect flue and/or inlet air piping for blockage, proper length, elbows, and termination. Check drain system. Correct as necessary. Check induced draft blower performance. Correct as necessary. Correct pressure switch set point or contact motion. Tighten or correct wiring connection. Clean H fitting. 	<ul style="list-style-type: none"> Turn power OFF prior to repair. Replace pressure switch with correct replacement part. Replace induced draft blower with correct replacement part. Take care to assemble/install H fitting in factory configuration. 		

TROUBLESHOOTING CODES

Symptoms of Abnormal Operation (Non-communicating & ComfortNet™ Thermostat)	Diagnostic/Status LED Codes	Fault Description	ComfortNet Thermostat Only Message	Code	Possible Causes	Corrective Actions	Notes & Cautions
<ul style="list-style-type: none"> Circulator blower runs continuously. No furnace operation. Integrated control module LED display provides E3 error code. ComfortNet thermostat "Call for Service" icon illuminated. ComfortNet thermostat scrolls "Check Furnace" message. 	E3	<ul style="list-style-type: none"> Primary limit. 	HIGH LIMIT OPEN	E3	<ul style="list-style-type: none"> Insufficient conditioned air over the heat exchanger. Blocked filters, restrictive ductwork, improper circulator blower speed, or failed circulator blower motor. Loose or improperly connected wiring. 	<ul style="list-style-type: none"> Check filters and ductwork for blockage. Clean filters or remove obstruction. Check circulator blower speed and performance. Correct speed or replace blower motor if necessary. Tighten or correct wiring connection. 	<ul style="list-style-type: none"> Turn power OFF prior to repair. See Specification Sheet applicable to your model for allowable rise range and proper circulator speed.
<ul style="list-style-type: none"> Induced draft blower and circulator blower runs continuously. No furnace operation. Integrated control module LED display provides E4 error code. ComfortNet thermostat "Call for Service" icon illuminated. ComfortNet thermostat scrolls "Check Furnace" message. 	E4	<ul style="list-style-type: none"> Flame sensed with no call for heat. 	IMPROPER FLAME	E4	<ul style="list-style-type: none"> Short to ground in flame sense circuit. Lingering burner flame. Slow closing gas valve. 	<ul style="list-style-type: none"> Correct short at flame sensor or in flame sensor wiring. Check for lingering flame. Verify proper operation of gas valve. 	<ul style="list-style-type: none"> Turn power OFF prior to repair.
<ul style="list-style-type: none"> No furnace operation. Integrated control module LED display provides E4 error code. 	E4	<ul style="list-style-type: none"> Open auxiliary input. 	AUXILIARY OPEN	E4	<ul style="list-style-type: none"> Open circuit between aux in or aux out. Missing jumper. Open float switch. 	<ul style="list-style-type: none"> Install jumper Inspect float switch 	<ul style="list-style-type: none"> Turn power OFF prior to repair.
<ul style="list-style-type: none"> No furnace operation. Integrated control module LED display provides E5 error code. ComfortNet thermostat displays "Battery Power". 	E5	<ul style="list-style-type: none"> Manual reset rollout switch is open Open Fuse 	ROLLOUT OPEN	E5	<ul style="list-style-type: none"> Orifice plate out of position. Blocked heat exchanger. Burners out of alignment. 	<ul style="list-style-type: none"> Reposition orifice plate. Remove blockage. Reposition burner. 	<ul style="list-style-type: none"> Turn power OFF prior to repair.
<ul style="list-style-type: none"> No furnace operation. Integrated control module LED display provides E5 error code. 	E5	<ul style="list-style-type: none"> Open Fuse 	Not Displayed	Not Displayed	<ul style="list-style-type: none"> Short in low voltage wiring 	<ul style="list-style-type: none"> Locate and correct short in low voltage wiring 	<ul style="list-style-type: none"> Turn power OFF prior to repair. Replace fuse with 3-amp automotive type
<ul style="list-style-type: none"> Normal furnace operation. Integrated control module LED display provides E6 error code. 	E6	<ul style="list-style-type: none"> Flame sense micro amp signal is low 	WEAK FLAME	E6	<ul style="list-style-type: none"> Flame sensor is coated/oxidized. Flame sensor incorrectly positioned in burner flame. Lazy burner flame due to improper gas pressure or combustion air. 	<ul style="list-style-type: none"> Sand flame sensor if coated/oxidized. Inspect for proper sensor alignment. Check inlet air piping for blockage, proper length, elbows, and termination. Compare current gas pressure to rating plate. Adjust as needed. 	<ul style="list-style-type: none"> Turn power OFF prior to repair. Sand flame sensor with steel wool. See "Vent/Flue Pipe" section for piping details. See rating plate for proper gas pressure.
<ul style="list-style-type: none"> Furnace fails to operate. Integrated control module LED display provides E7 error code. ComfortNet thermostat "Call for Service" icon illuminated. ComfortNet thermostat scrolls "Check Furnace" message. 	E7	<ul style="list-style-type: none"> Problem with igniter circuit. 	IGNITER FAULT	E7	<ul style="list-style-type: none"> Improperly connected igniter. Shorted igniter. Poor unit ground. Igniter relay fault on integrated control module. 	<ul style="list-style-type: none"> Check and correct wiring from integrated control module to igniter. Replace shorted igniter. Check and correct unit ground wiring. Check igniter output from control. Replace if necessary. 	<ul style="list-style-type: none"> Turn power OFF prior to repair. Replace igniter with correct replacement part. Replace control with correct replacement part.

TROUBLESHOOTING CODES

Symptoms of Abnormal Operation (Non-communicating & ComfortNet™ Thermostat)	Diagnostic/Status LED Codes	Fault Description	ComfortNet Thermostat Only		Possible Causes	Corrective Actions	Notes & Cautions
			Message	Code			
<ul style="list-style-type: none"> Furnace fails to operate on high stage; furnace operates normally on low stage. Integrated control module LED display provides EB error code. 	EB	<ul style="list-style-type: none"> High stage pressure switch circuit is closed at start of heating cycle. Induced draft blower is operating. Furnace is operating on low stage only 	<i>PS2</i> <i>CLOSED</i>	<i>E8</i>	<ul style="list-style-type: none"> High stage pressure switch contacts sticking. Shorts in pressure switch circuit wiring. 	<ul style="list-style-type: none"> Replace high stage pressure switch. Repair short in wiring 	<ul style="list-style-type: none"> Turn power OFF prior to repair. Replace pressure switch with correct replacement part.
<ul style="list-style-type: none"> Furnace fails to operate on high stage; furnace operates normally on low stage. Integrated control module LED display provides E9 error code. 	E9	<ul style="list-style-type: none"> High stage pressure switch circuit is not closed. Induced draft blower is operating. Furnace is operating on low stage only 	<i>PS2</i> <i>OPEN</i>	<i>E9</i>	<ul style="list-style-type: none"> Pressure switch hose blocked, pinched, or connected improperly. Blocked flue and/or inlet air pipe, blocked drain system or weak induced draft blower. Incorrect pressure switch set point or malfunctioning switch contacts. Loose or improperly connected wiring. 	<ul style="list-style-type: none"> Inspect pressure switch hose. Repair/replace if necessary. Inspect flue and/or inlet air piping for blockage, proper length, elbows, and termination. Check drain system. Correct as necessary. Check induced draft blower performance. Correct as necessary. Correct pressure switch set point or contact motion. Tighten or correct wiring connection. 	<ul style="list-style-type: none"> Turn power OFF prior to repair. Replace pressure switch with correct replacement part. Replace induced draft blower with correct replacement part.
<ul style="list-style-type: none"> Furnace fails to operate. Integrated control module LED display provides EA error code. ComfortNet thermostat “Call for Service” icon illuminated. ComfortNet thermostat scrolls “Check Furnace” message. 	EA	<ul style="list-style-type: none"> Polarity of 115 volt AC is reversed 	<i>REVERSED</i> <i>PLTY</i>	<i>EA</i>	<ul style="list-style-type: none"> Polarity of 115 volt AC power to furnace or integrated module is reversed. Reversed unit ground. 	<ul style="list-style-type: none"> Review wiring diagram to correct polarity. Verify proper ground. Correct if necessary. Check and correct wiring. 	<ul style="list-style-type: none"> Turn power OFF prior to repair.
<ul style="list-style-type: none"> Furnace fails to operate. Integrated control module LED display provides d0 error code. ComfortNet thermostat “Call for Service” icon illuminated. ComfortNet thermostat scrolls “Check Furnace” message. 	d0	<ul style="list-style-type: none"> Data not yet on network. 	<i>NO NET</i> <i>DATA</i>	<i>d0</i>	<ul style="list-style-type: none"> Furnace does not contain any shared data. 	<ul style="list-style-type: none"> Populate shared data set using memory card. 	<ul style="list-style-type: none"> Turn power OFF prior to repair Use memory card for the specific model. Insert memory card BEFORE turning power ON. Memory card may be removed after data is loaded. Turn power OFF before removing memory card. Error code will be cleared once data is loaded.

TROUBLESHOOTING CODES

Symptoms of Abnormal Operation (Non-communicating & ComfortNet™ Thermostat)	Diagnostic/Status LED Codes		Fault Description	ComfortNetThermostat Only		Possible Causes	Corrective Actions	Notes & Cautions
	Message	Code						
<ul style="list-style-type: none"> Operation different than expected or no operation. Integrated control module LED display provides d1 error code. ComfortNet thermostat "Call for Service" icon illuminated. ComfortNet thermostat scrolls "Check Furnace" message. 	d1	INVALID MC DATA	<ul style="list-style-type: none"> Invalid memory card data. 		d4	<ul style="list-style-type: none"> Shared data set on memory card has been rejected by integrated control module. 	<ul style="list-style-type: none"> Verify shared data set is correct for the specific model. Repopulate data using correct memory card if required. 	<ul style="list-style-type: none"> Turn power OFF prior to repair. Use memory card for the specific model. Insert memory card BEFORE turning power ON. Memory card may be removed after data is loaded. Turn power OFF before removing memory card. Error code will be cleared once data is loaded.
<ul style="list-style-type: none"> Furnace fails to operate. Integrated control module LED display provides b0 error code. ComfortNet thermostat "Call for Service" icon illuminated. ComfortNet thermostat scrolls "Check Furnace" message. 	b0	MOTOR NOT RUN	<ul style="list-style-type: none"> Circulator blower motor is not running when it should be running. 		b0	<ul style="list-style-type: none"> Loose wiring connection at circulator motor power leads or circulator motor power leads disconnected. Open circuit in inductor or loose wiring connection at inductor (3/4 Hp and 1 Hp models only). Failed circulator blower motor. 	<ul style="list-style-type: none"> Tighten or correct wiring connection. Verify continuous circuit through inductor. Replace if open or short circuit. Check circulator blower motor. Replace if necessary. 	<ul style="list-style-type: none"> Turn power OFF prior to repair. Replace inductor with correct replacement part. Replace circulator motor with correct replacement part.
<ul style="list-style-type: none"> Furnace fails to operate. Integrated control module LED display provides b1 error code. ComfortNet thermostat "Call for Service" icon illuminated. ComfortNet thermostat scrolls "Check Furnace" message. 	b1	MOTOR COMM	<ul style="list-style-type: none"> Integrated control module has lost communications with circulator blower motor. 		b1	<ul style="list-style-type: none"> Loose wiring connection at circulator motor control leads. Failed circulator blower motor. Failed integrated control module. 	<ul style="list-style-type: none"> Tighten or correct wiring connection. Check circulator blower motor. Replace if necessary. Check integrated control module. Replace if necessary. 	<ul style="list-style-type: none"> Turn power OFF prior to repair. Replace circulator motor with correct replacement part. Replace integrated control module with correct replacement part.
<ul style="list-style-type: none"> Furnace fails to operate. Integrated control module LED display provides b2 error code. ComfortNet thermostat "Call for Service" icon illuminated. ComfortNet thermostat scrolls "Check Furnace" message. 	b2	MOTOR MISMATCH	<ul style="list-style-type: none"> Circulator blower motor horse power in shared data set does not match circulator blower motor horse power. 		b2	<ul style="list-style-type: none"> Incorrect circulator blower motor in furnace. Incorrect shared data set in integrated control module. 	<ul style="list-style-type: none"> Verify circulator blower motor horse power is the same specified for the specific furnace model. Replace if necessary. Verify shared data set is correct for the specific model. Repopulate data using correct memory card if required. 	<ul style="list-style-type: none"> Turn power OFF prior to repair. Replace motor with correct replacement part. Use memory card for the specific model. Insert memory card BEFORE turning power ON. Memory card may be removed after data is loaded. Turn power OFF before removing memory card. Error code will be cleared once shared data and motor horse power match.
<ul style="list-style-type: none"> Furnace operates at reduced performance. Airflow delivered is less than expected. Integrated control module LED display provides b3 error code. 	b3	MOTOR LIMITS	<ul style="list-style-type: none"> Circulator blower motor is operating in a power, temperature, or speed limiting condition. 		b3	<ul style="list-style-type: none"> Blocked filters. Restrictive ductwork. Undersized ductwork. High ambient temperatures. 	<ul style="list-style-type: none"> Check filters for blockage. Clean filters or remove obstruction. Check ductwork for blockage. Remove obstruction. Verify all registers are fully open. Verify ductwork is appropriately sized for system. Resize/replace ductwork if necessary. See "Product Description" and "Location Requirements & Considerations" for furnace installation requirements. 	<ul style="list-style-type: none"> Turn power OFF prior to repair.

TROUBLESHOOTING CODES

Symptoms of Abnormal Operation (Non-communicating & ComfortNet™ Thermostat)	Diagnostic/Status LED Codes	Fault Description	ComfortNet Thermostat Only Message Code	Possible Causes	Corrective Actions	Notes & Cautions
<ul style="list-style-type: none"> Furnace fails to operate. Integrated control module LED display provides b4 error code. ComfortNet thermostat “Call for Service” icon illuminated. ComfortNet thermostat scrolls “Check Furnace” message. 	b4	<ul style="list-style-type: none"> Circulator blower motor senses a loss of rotor control. Circulator blower motor senses high current. 	<i>MOTOR TRIPS</i> <i>b4</i>	<ul style="list-style-type: none"> Abnormal motor loading, sudden change in speed or torque, sudden blockage of furnace air inlet or outlet. High loading conditions, blocked filters, very restrictive ductwork, blockage of furnace air inlet or outlet. 	<ul style="list-style-type: none"> Check filters, filter grills/registers, duct system, and furnace air inlet/outlet for blockages. 	<ul style="list-style-type: none"> Turn power OFF prior to repair.
<ul style="list-style-type: none"> Furnace fails to operate. Integrated control module LED display provides b5 error code. ComfortNet thermostat “Call for Service” icon illuminated. ComfortNet thermostat scrolls “Check Furnace” message. 	b5	<ul style="list-style-type: none"> Circulator blower motor fails to start 10 consecutive times. 	<i>MTR LCKD ROTOR</i> <i>b5</i>	<ul style="list-style-type: none"> Obstruction in circulator blower housing. Seized circulator blower motor bearings. Failed circulator blower motor. 	<ul style="list-style-type: none"> Check circulator blower for obstructions. Remove and repair/replace wheel/motor if necessary. Check circulator blower motor shaft rotation and motor. Replace motor if necessary. 	<ul style="list-style-type: none"> Turn power OFF prior to repair. Replace motor with correct replacement part. Replace wheel with correct replacement part.
<ul style="list-style-type: none"> Furnace fails to operate. Integrated control module LED display provides b6 error code. ComfortNet thermostat “Call for Service” icon illuminated. ComfortNet thermostat scrolls “Check Furnace” message. 	b6	<ul style="list-style-type: none"> Circulator blower motor shuts down for over or under voltage condition. Circulator blower motor shuts down due to over temperature condition on power module. 	<i>MOTOR VOLTS</i> <i>b6</i>	<ul style="list-style-type: none"> High AC line voltage to furnace. Low AC line voltage to furnace. High ambient temperatures. 	<ul style="list-style-type: none"> Check power to furnace. Verify line voltage to furnace is within the range specified on the furnace rating plate. See “<i>Product Description</i>” and “<i>Location Requirements & Considerations</i>” for furnace installation requirements. 	<ul style="list-style-type: none"> Turn power OFF prior to repair.
<ul style="list-style-type: none"> Furnace fails to operate. Integrated control module LED display provides b7 error code. ComfortNet thermostat “Call for Service” icon illuminated. ComfortNet thermostat scrolls “Check Furnace” message. 	b7	<ul style="list-style-type: none"> Circulator blower motor does not have enough information to operate properly. Motor fails to start 40 consecutive times. 	<i>MOTOR PARAMS</i> <i>b7</i>	<ul style="list-style-type: none"> Error with integrated control module. Motor has a locked rotor condition. 	<ul style="list-style-type: none"> Check integrated control module. Verify control is populated with correct shared data set. See data errors above for details. Check for locked rotor condition (see error code above for details). 	<ul style="list-style-type: none"> Turn power OFF prior to repair. Replace with correct replacement part(s). Use memory card for the specific model.
<ul style="list-style-type: none"> Furnace operates at reduced performance or operates on low stage when high stage is expected. Integrated control module LED display provides b9 error code. 	b9	<ul style="list-style-type: none"> Airflow is lower than demanded. 	<i>LOW ID AIRFLOW</i> <i>b9</i>	<ul style="list-style-type: none"> Blocked filters. Restrictive ductwork. Undersized ductwork. 	<ul style="list-style-type: none"> Check filters for blockage. Clean filters or remove obstruction. Check ductwork for blockage. Remove obstruction. Verify all registers are fully open. Verify ductwork is appropriately sized for system. Resize/replace ductwork if necessary. 	<ul style="list-style-type: none"> Turn power OFF prior to repair.

STATUS CODES

I	I	INTERNAL CONTROL FAULT/NO POWER
O	n	NORMAL OPERATION
E	0	LOCKOUT DUE TO EXCESSIVE RETRIES
E	1	LOW STAGE PRESSUE SWITCH STUCK CLOSED AT START OF HEATING CYCLE
E	2	LOW STAGE PRSSURE SWITCH STUCK OPEN
E	3	OPEN HIGH LIMIT SWITCH
E	4	FLAME DETECTED WHEN NO FLAME SHOULD BE PRESENT
E	5	OPEN FUSE
E	6	LOW FLAME SIGNAL
E	7	IGNITER FAULT OR IMPROPER GROUNDING
E	8	HIGH STAGE PRESSURE SWITCH STUCK CLOSED AT START OF HEATING CYCLE
E	9	HIGH STAGE PRSSURE SWITCH STUCK OPEN
E	A	REVERSED 115 VAC POLARITY
E	d	ROLLOUT SWITCH OPEN
E	F	AUXILIARY INPUT OPEN
d	0	DATA NOT YET ON NETWORK
d	4	INVALID MEMORY CARD DATA
b	0	BLOWER MOTOR NOT RUNNING
b	1	BLOWER COMMUNICATION ERROR
b	2	BLOWER HP MIS-MATCH
b	3	BLOWER MOTOR OPERATING IN POWER, TEMPERATURE, OR SPEED LIMIT
b	4	BLOWER MOTOR CURRENT TRIP OR LOST ROTOR
b	5	BLOWER MOTOR LOCKED ROTOR
b	6	OVER/UNDER VOLTAGE TRIP OR OVER TEMPERATURE TRIP
b	7	INCOMPLETE PARAMETERS SENT TO MOTOR
b	9	LOW INDOOR AIRFLOW
C	1	LOW STAGE COOL
C	2	HIGH STAGE COOL
5	0	% OF HIGH HEAT
H	I	HIGH HEAT
F	I	CONTINUOUS FAN
F	t	FIELD TEST MODE
1	2	CFM x 100, ALTERNATES WITH THERMOSTAT CALL & GAS HEAT OPERATING PERCENTAGE.

HIGH VOLTAGE!
Disconnect ALL power before servicing or installing this unit. Multiple power sources may be present. Failure to do so may cause property damage, personal injury or death.

WARNING

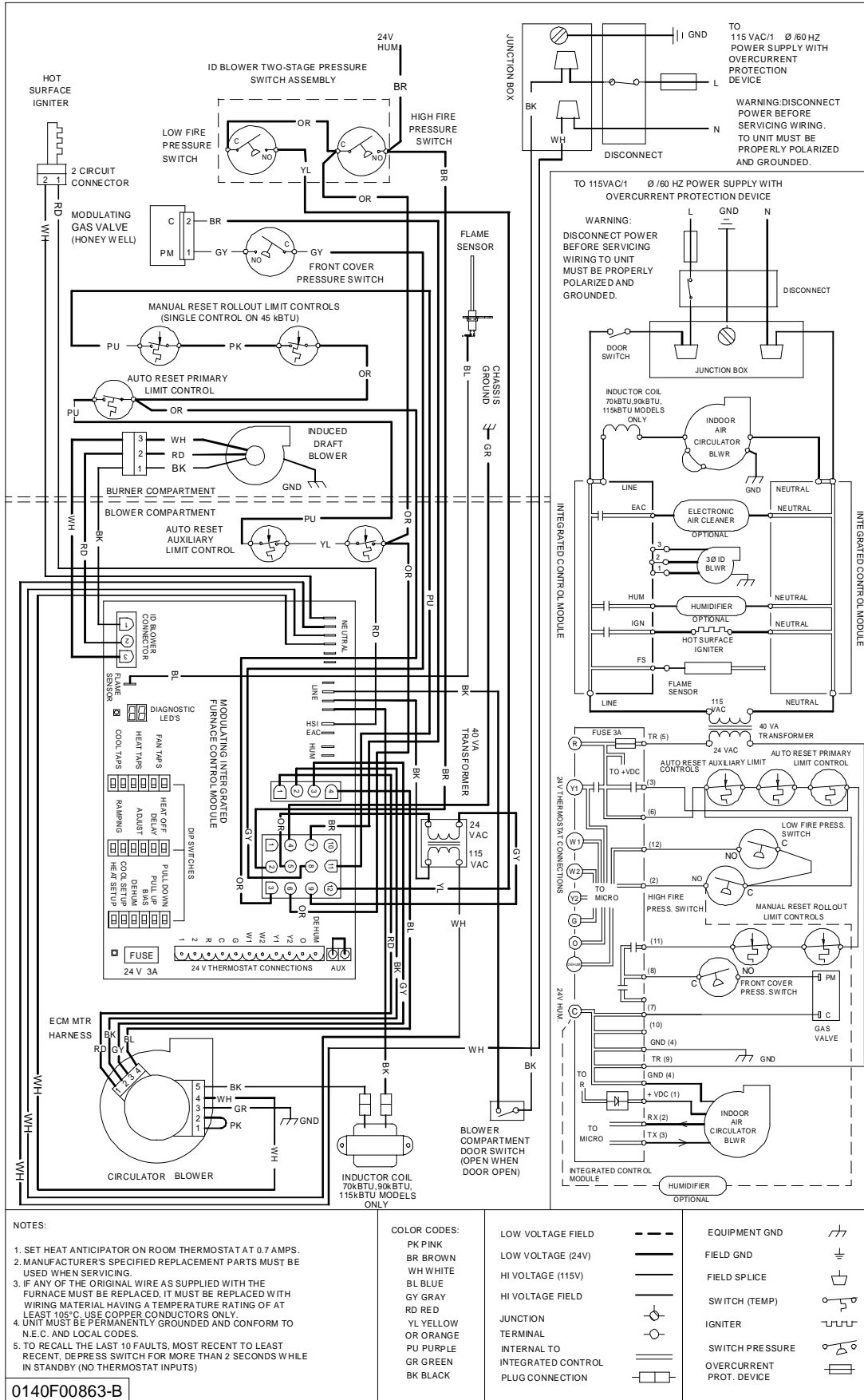

Wiring is subject to change. Always refer to the wiring diagram on the unit for the most up-to-date wiring.

*5151 San Felipe Suite 500
Houston, TX 77056*
www.goodmanmfg.com • www.amana-hac.com

© 2011 Goodman Manufacturing Company, L.P.