



Air Conditioning & Heating

# GMH95/GCH95

## MULTI-POSITION, MULTI-SPEED GAS FURNACES

### UP TO 95% AFUE

#### Standard Features

- Dual-diameter tubular heat exchanger
- Two-stage gas valve with DualSaver™ technology that allows installer to activate the two-stage valve with the flip of a dipswitch
- 110V Silicon Nitride igniter
- Furnace control board with self-diagnostics, color-coded low-voltage terminals, and provisions for electronic air cleaner and 24-volt humidifiers
- Control board stores the last five diagnostic codes in memory; simple push-button activation outputs the fault history to a flashing red LED
- Low constant fan allows homeowner to activate the low heat speed to efficiently circulate air throughout the home
- Self-adjusting feature automatically adjusts to high or low stage based on outside temperature without an outdoor temperature sensor
- Dual-certified for sealed combustion direct vent (2-pipe) or non-direct vent (1-pipe) applications
- Easy-to-install top venting is standard; alternate flue/vent located on the right (GMH95)
- All models comply with California NOx emissions standards

#### Cabinet Features

- Fully insulated, heavy-gauge steel cabinet with durable baked-enamel finish
- Foil-faced insulation lines the heat exchanger
- Designed for multi-position installation — GMH95: upflow, horizontal left or right; GCH95/GCH9: downflow, horizontal left or right
- Airtight solid bottom for side-return applications and easy-cut tabs for effortless removal in bottom air inlet applications
- Convenient left/right connection for gas/electric service
- Coil and furnace fit flush for most installations



Applies to 95% furnaces only.

#### Contents

Nomenclature.....	2
Product Specifications.....	3
Dimensions.....	5
Airflow Data.....	7
Wiring Diagrams.....	9
Accessories.....	14



\* Complete warranty details available from your local dealer or at [www.goodmanmfg.com](http://www.goodmanmfg.com). To receive the Lifetime Heat Exchanger Limited Warranty (good for as long as you own your home), 10-Year Unit Replacement Limited Warranty and 10-Year Parts Limited Warranty, online registration must be completed within 60 days of installation. Online registration is not required in California or Québec.



NOMENCLATURE

	G	M	H	95	045	4	B	X	A		
	1	2	3	4,5	6,7,8	9	10	11	12		
<b>Brand</b>	G Goodman® Brand or Distinctions™									<b>Revisions</b>	
										A Initial Release	
										B 1st Revision	
										C 2nd Revision	
<b>Airflow Direction</b>	C Downflow/Horizontal									<b>NOx</b>	
	D Dedicated Downflow									N Natural Gas	
	H High Airflow									X Low NOx	
	K Dedicated Upflow									<b>Cabinet Width</b>	
	M Upflow/Horizontal									A 14"	
<b>Description</b>	V Two-Stage/Variable-speed									B 17½"	
	H Two-Stage/Multi-speed									C 21"	
	S Single-Stage/Multi-speed									D 24½"	
	E Two-Stage/EEM Motor									<b>Maximum CFM @ 0.5" ESP</b>	
<b>AFUE</b>	95 95%									3 1200	5 2000
	9 93%+									4 1600	
	8 80%									<b>MBTU/h</b>	
										045: 45,000	115: 115,000
										070: 70,000	140: 140,000
										090: 90,000	



## SPECIFICATIONS FOR GMH95

	GMH95 0453BXA	GMH95 0703BXA	GMH95 0704CXA	GMH95 0904CXA	GMH95 0905CXA	GMH95 1155DXA
<b>HEATING CAPACITY</b>						
Input <sup>1</sup>	46,000	69,000	69,000	92,000	92,000	115,000
Natural Gas Output <sup>1</sup>	44,600	66,400	66,400	89,000	88,400	110,500
LP Gas Output <sup>1</sup>	39,330	58,995	58,995	78,660	78,660	98,325
AFUE <sup>2</sup>	95	95	95	95	95	95
Available AC @ 0.5" ESP	3	3	4	4	5	5
Temperature Rise Range (°F)	35 - 65	30 - 60	35 - 65	30 - 60	30 - 60	35 - 65
<b>CIRCULATOR BLOWER</b>						
Size (D x W)	10" x 8"	10" x 8"	10" x 10"	10" x 10"	11" x 10"	11" x 10"
Horsepower @ 1075 RPM	⅓	⅓	½	½	¾	¾
Speed	4	4	4	4	4	4
Vent Diameter <sup>3</sup>	2"	2"	2"	2"	3"	3"
No. of Burners	2	3	3	4	4	5
Disposable Filter Size (in <sup>2</sup> )	580	580	770	770	960	960
<b>ELECTRICAL DATA</b>						
Min. Circuit Ampacity <sup>4</sup>	9.4	9.4	13.8	13.8	13.2	13.2
Max. Overcurrent Device (amps) <sup>5</sup>	15	15	15	15	15	15
<b>SHIP WEIGHT (LBS)</b>	132	135	136	158	172	175

<sup>1</sup> Natural Gas BTU/h. For altitudes above 2,000', reduce input rating 4% for each 1,000' above sea level.

<sup>2</sup> DOE AFUE based upon Isolated Combustion System (ICS)

<sup>3</sup> Installer must supply one or two PVC pipes: one for combustion air (optional) and one for the flue outlet (required). Vent pipe must be either 2" or 3" in diameter, depending upon furnace input, number of elbows, length of run and installation (1 or 2 pipes). The optional Combustion Air Pipe is dependent on installation/code requirements and must be 2" or 3" diameter PVC.

<sup>4</sup> Minimum Circuit Ampacity = (1.25 x Circulator Blower Amps) + ID Blower amps. Wire size should be determined in accordance with National Electrical Codes. Extensive wire runs will require larger wire sizes.

<sup>5</sup> Maximum Overcurrent Protection Device refers to maximum recommended fuse or circuit breaker size. May use fuses or HACR-type circuit breakers of the same size as noted.

**NOTES:**

- All furnaces are manufactured for use on 115 VAC, 60 Hz, single-phase electrical supply.
- Gas Service Connection ½" FPT
- Important: Size fuses and wires properly and make electrical connections in accordance with the National Electrical Code and/or all existing local codes.

**SPECIFICATIONS FOR GCH95/GCH9**

	<b>GCH95 0453BX</b>	<b>GCH95 0703BX</b>	<b>GCH95 0704CX</b>	<b>GCH95 0904CX</b>	<b>GCH95 0905DX</b>	<b>GCH9 1155DX</b>
<b>HEATING CAPACITY</b>						
Input <sup>1</sup>	46,000	69,000	69,000	92,000	92,000	115,000
Natural Gas Output <sup>1</sup>	43,700	65,550	65,550	87,400	87,400	106,500
LP Gas Output <sup>1</sup>	39,330	58,995	58,995	78,660	78,660	96,255
AFUE <sup>2</sup>	95.0	95.0	95.0	95.0	95.0	93.0
Available AC @ 0.5" ESP	3	3	4	4	5	5
Temperature Rise Range (°F)	25-55	35-65	25-55	40 - 70	35-65	40 - 70
<b>CIRCULATOR BLOWER</b>						
Size (D x W)	10" x 8"	10" x 8"	10" x 10"	10" x 10"	11" x 10"	11" x 10"
Horsepower @ 1075 RPM	⅓	⅓	½	½	¾	¾
Speed	4	4	4	4	4	4
Vent Diameter <sup>3</sup>	2"	2"	2"	2"	2"	2"
No. of Burners	2	3	3	4	4	5
Disposable Filter Size (in <sup>2</sup> )	576	564	564	752	752	940
<b>ELECTRICAL DATA</b>						
Min. Circuit Ampacity <sup>4</sup>	9.8	9.8	12.9	12.9	13.4	13.2
Max. Overcurrent Device (amps) <sup>5</sup>	15	15	15	15	15	15
<b>SHIP WEIGHT (LBS)</b>						
	132	135	135	156	173	175

<sup>1</sup> Natural Gas BTU/h. For altitudes above 2,000', reduce input rating 4% for each 1,000' above sea level.

<sup>2</sup> DOE AFUE based upon Isolated Combustion System (ICS)

<sup>3</sup> Installer must supply one or two PVC pipes: one for combustion air (optional) and one for the flue outlet (required). Vent pipe must be either 2" or 3" in diameter, depending upon furnace input, number of elbows, length of run and installation (1 or 2 pipes). The optional Combustion Air Pipe is dependent on installation/code requirements and must be 2" or 3" diameter PVC.

<sup>4</sup> Minimum Circuit Ampacity = (1.25 x Circulator Blower Amps) + ID Blower amps. Wire size should be determined in accordance with National Electrical Codes. Extensive wire runs will require larger wire sizes.

<sup>5</sup> Maximum Overcurrent Protection Device refers to maximum recommended fuse or circuit breaker size. May use fuses or HACR-type circuit breakers of the same size as noted.

**NOTES:**

- All furnaces are manufactured for use on 115 VAC, 60 Hz, single-phase electrical supply.
- Gas Service Connection ½" FPT
- Important: Size fuses and wires properly and make electrical connections in accordance with the National Electrical Code and/or all existing local codes.

# GMH95 DIMENSIONS

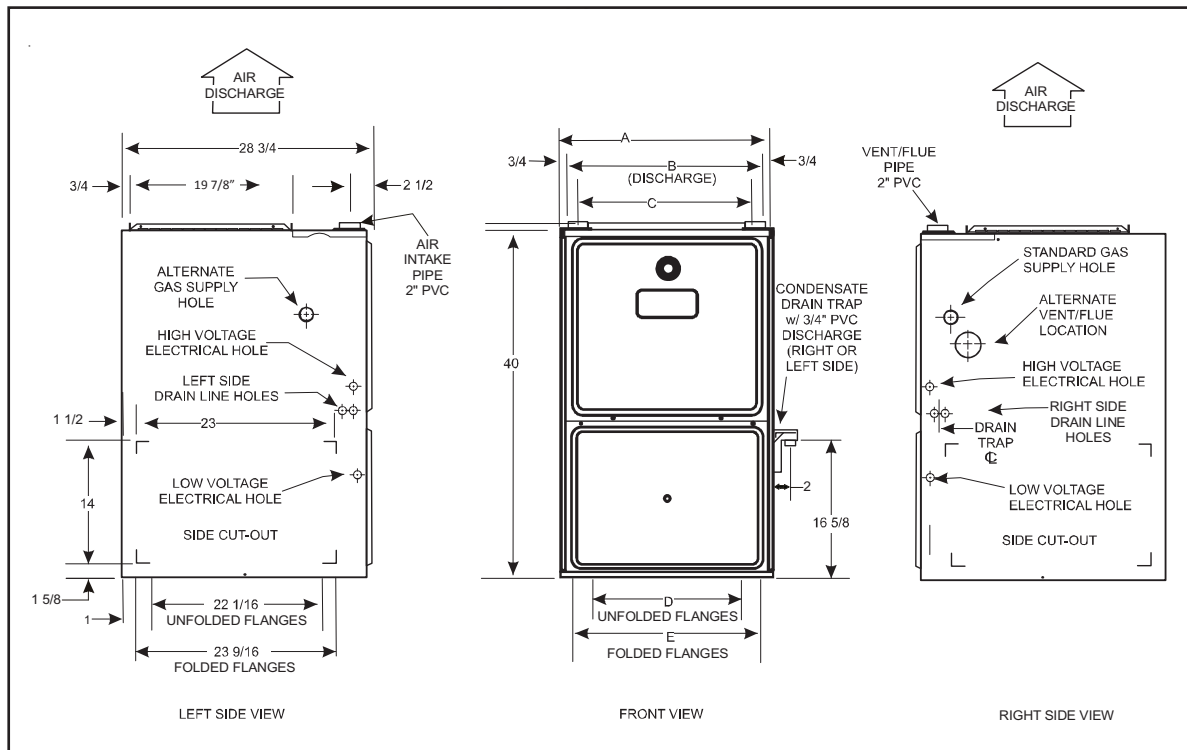

MODEL	A	B	C	D	E
GMH950453BXA	17 1/2"	16"	13 1/8"	12 1/8"	13 5/8"
GMH950703BXA	17 1/2"	16"	13 1/8"	12 1/8"	13 5/8"
GMH950704CXA	21"	19 1/2"	16 5/8"	16"	17 1/2"
GMH950904CXA	21"	19 1/2"	16 5/8"	16"	17 1/2"
GMH950905CXA	21"	19 1/2"	20 5/8"	19 5/8"	20 5/8"
GMH951155DXA	24 1/2"	23"	20 5/8"	19 5/8"	20 5/8"

**NOTES:**

- Installer must supply one or two PVC pipes: one for combustion air (optional) and one for the flue outlet (required). Vent pipe must be either 2" or 3" in diameter, depending upon furnace input, number of elbows, length of run, and installation (1 or 2 pipes). The optional combustion air pipe is dependent on installation/code requirements and must be 2" or 3" diameter PVC.
- Line voltage wiring can enter through the right or left side of furnace. Low-voltage wiring can enter through the right or left side of furnace.
- Conversion kits for high-altitude natural gas operation are available. Contact your Goodman distributor or dealer for details.
- Installer must supply the following gas line fittings, according to which entrance is used:  
 Left: One 90° street elbow; one 2 1/2" pipe nipple; one 90° elbow; straight pipe; one ground joint union  
 Right: Straight pipe to reach gas valve
- Installations using a bottom return: Failure to unfold duct flanges will reduce airflow area by approximately 18%. This could result in performance and noise issues.

## MINIMUM CLEARANCES TO COMBUSTIBLE MATERIALS

POSITION	SIDES	REAR	FRONT	BOTTOM	FLUE	TOP
Upflow	0"	0"	1"	C	0"	1"
Horizontal	6"	0"	1"	C	0"	4"

- C = If placed on combustible floor, the floor MUST be wood ONLY.
- For servicing or cleaning, a 24" front clearance is recommended.
- Unit connections (electrical, flue, and drain) may necessitate greater clearances than the minimum clearances listed above.
- In all cases, accessibility clearance must take precedence over clearances from the enclosure where accessibility clearances are greater.
- Approved for line contact in the horizontal position

# GCH95/GCH9 DIMENSIONS

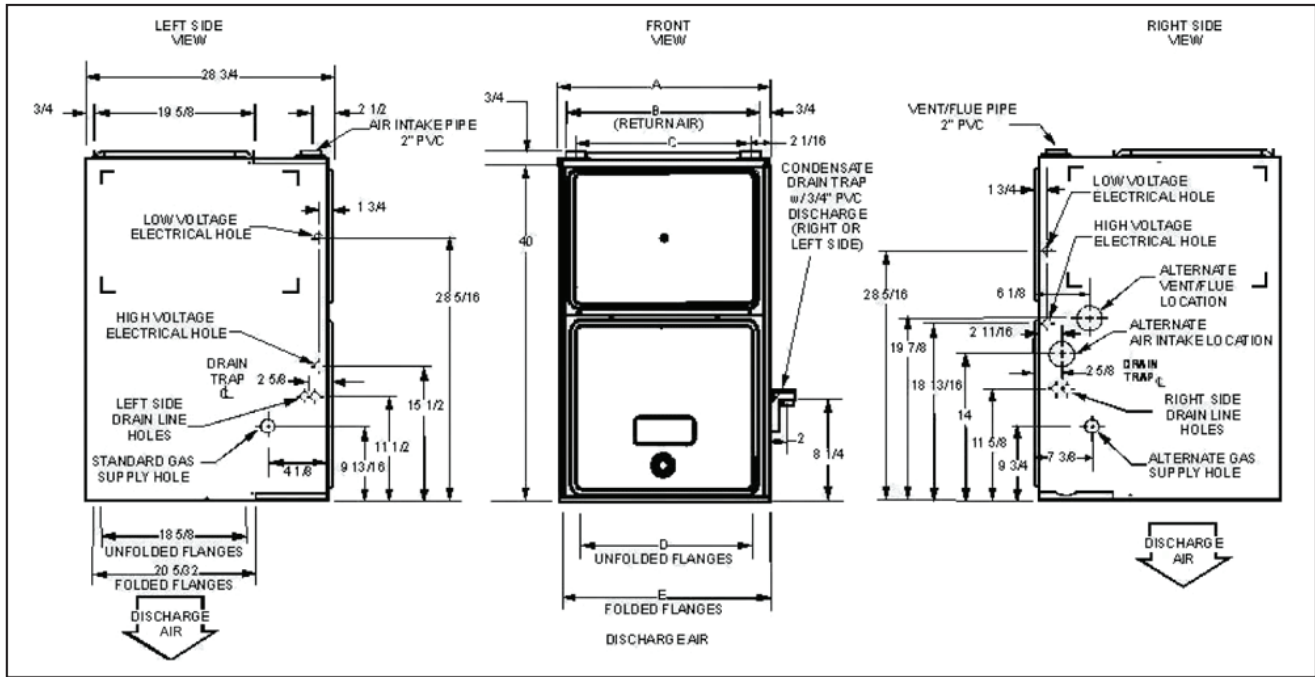

MODEL	A	B	C	D	E
GCH950453BXA	17½"	16"	12¾"	14½"	16"
GCH950703BXA	17½"	16"	12¾"	14½"	16"
GCH950704CXA	21"	19½"	16¾"	18"	19½"
GCH950904CXA	21"	19½"	16¾"	18"	19½"
GCH950905DXA	24½"	23"	20¾"	21½"	23"
GCH91155DXA	24½"	23"	20¾"	21½"	23"

**NOTES:**

- Installer must supply one or two PVC pipes: one for combustion air (optional) and one for the flue outlet (required). Vent pipe must be either 2" or 3" in diameter, depending upon furnace input, number of elbows, length of run, and installation (1 or 2 pipes). The optional combustion air pipe is dependent on installation/code requirements and must be 2" or 3" diameter PVC.
- Line voltage wiring can enter through the right or left side of furnace. Low-voltage wiring can enter through the right or left side of furnace.
- Conversion kits for high-altitude natural gas operation are available. Contact your Goodman distributor or dealer for details.
- Installer must supply the following gas line fittings, according to which entrance is used:  
**Left:** One 90° street elbow; one 2½" pipe nipple; one 90° elbow; straight pipe; one ground joint union  
**Right:** Straight pipe to reach gas valve
- Installations using a bottom return: Failure to unfold duct flanges will reduce airflow area by approximately 18%. This could result in performance and noise issues.

## MINIMUM CLEARANCES TO COMBUSTIBLE MATERIALS

POSITION	SIDES	REAR	FRONT	BOTTOM	FLUE	TOP
Downflow	0"	0"	1"	NC	0"	1"
Horizontal	6"	0"	1"	C	0"	4"

C = Combustible: If placed on combustible floor, the floor MUST be wood ONLY.  
 NC = Non-Combustible: A combustible floor sub-base must be used for installation on combustible flooring

**NOTES:**

- For servicing or cleaning, a 24" front clearance is recommended.
- Unit connections (electrical, flue and drain) may necessitate greater clearances than the minimum clearances listed below.
- In all cases, accessibility clearance must take precedence over clearances from the enclosure where accessibility clearances are greater.

# GMH95 AIRFLOW DATA

(CFM & TEMPERATURE RISE VS. EXTERNAL STATIC PRESSURE)

MODEL	MOTOR SPEED	TONS AC <sup>1</sup>	EXTERNAL STATIC PRESSURE, (INCHES WATER COLUMN)												
			0.1		0.2		0.3		0.4		0.5		0.6	0.7	0.8
			CFM	RISE	CFM	RISE	CFM	RISE	CFM	RISE	CFM	RISE	CFM	CFM	CFM
GMH95 0453BXA	High	3	1,352	29	1,318	30	1,260	31	1,202	33	1,128	35	1,044	955	853
	Med	2.5	1,214	32	1,172	34	1,123	35	1,064	37	1,012	39	938	859	741
	Med-Lo	2	997	40	994	40	960	41	923	43	884	45	817	741	611
	Low	1.5	757	52	753	52	734	54	704	56	674	59	620	524	438
GMH95 0703BXA	High	3	1,449	41	1,409	42	1,326	45	1,273	47	1,201	49	1,194	1,136	1,018
	Med	2.5	1,192	50	1,172	51	1,141	52	1,094	54	1,046	57	973	904	793
	Med-Lo	2	981	61	962	62	943	63	917	65	888	67	830	764	665
	Low	1.5	750	79	730	81	714	83	692	86	657	90	620	570	502
GMH95 0704CXA	High	4	2,069	29	1,965	30	1,871	32	1,756	34	1,661	36	1,549	1,415	1,275
	Med	3.5	1,752	34	1,724	34	1,667	36	1,603	37	1,488	40	1,402	1,290	1,082
	Med-Lo	3	1,437	41	1,437	41	1,417	42	1,369	43	1,320	45	1,256	1,140	984
	Low	2.5	1,184	50	1,177	50	1,161	51	1,132	52	1,095	54	1,047	928	837
GMH95 0904CXA	High	4	1,970	40	1,874	42	1,757	45	1,667	48	1,566	51	1,431	1,334	1,182
	Med	3.5	1,713	46	1,650	48	1,572	50	1,510	52	1,418	56	1,313	1,211	1,079
	Med-Lo	3	1,439	55	1,412	56	1,370	58	1,327	60	1,260	63	1,166	1,078	956
	Low	2.5	1,183	67	1,155	69	1,122	71	1,108	72	1,062	75	1,011	931	816
GMH95 0905CXA	High	5	2,147	37	2,114	37	2,057	39	2,030	39	1,978	40	1,889	1,784	1,713
	Med	4	1,675	47	1,686	47	1,640	48	1,623	49	1,557	51	1,501	1,455	1,360
	Med-Lo	3.5	1,489	53	1,470	54	1,436	55	1,409	56	1,361	58	1,318	1,243	1,130
	Low	3	1,307	61	1,265	63	1,234	64	1,203	66	1,168	68	1,096	1,053	991
GMH95 1155DXA	High	5	2,134	46	2,103	47	2,029	48	1,941	51	1,906	51	1,818	1,733	1,625
	Med	4	1,678	58	1,643	60	1,643	60	1,577	62	1,527	64	1,489	1,423	1,339
	Med-Lo	3.5	1,453	68	1,440	68	1,426	69	1,363	72	1,349	73	1,314	1,253	1,205
	Low	3	1,259	78	1,239	79	1,220	80	1,181	83	1,159	85	1,118	1,082	1,015

<sup>1</sup> @0.5" ESP

**NOTES:**

- CFM in chart is without filter(s). Filters do not ship with this furnace, but must be provided by the installer.
- All furnaces ship as high-speed cooling and medium-speed heating. Installer must adjust blower cooling & heating speed as needed.
- For most applications, about 400 CFM per ton when cooling is desirable.
- INSTALLATION IS TO BE ADJUSTED TO OBTAIN TEMPERATURE RISE WITHIN THE RANGE SPECIFIED ON THE RATING PLATE.
- The chart is for information only. For satisfactory operation, external static pressure should not exceed value shown on the rating plate.
- The above chart is for furnaces installed at 0-2000 feet. At higher altitudes, a properly de-rated unit will have approximately the same temperature rise at a particular CFM, while ESP at the CFM will be lower.

## GCH95/GCH9 AIRFLOW DATA

(CFM & TEMPERATURE RISE VS. EXTERNAL STATIC PRESSURE)

MODEL	MOTOR SPEED	TONS AC <sup>1</sup>	EXTERNAL STATIC PRESSURE, (INCHES WATER COLUMN)												
			0.1		0.2		0.3		0.4		0.5		0.6	0.7	0.8
			CFM	RISE	CFM	RISE	CFM	RISE	CFM	RISE	CFM	RISE	CFM	CFM	CFM
GCH95 0453BX	High	3	1,415	28	1,352	30	1,290	31	1,196	34	1,127	36	1,035	936	825
	Med	2.5	1,221	33	1,178	34	1,127	36	1,073	38	1,007	40	932	834	733
	Med-Lo	2	1,034	39	1,000	40	976	41	935	43	881	46	818	733	662
	Low	1.5	860	47	845	48	812	50	783	51	740	54	682	619	534
GCH95 0703BX	High	3	1,431	42	1,368	44	1,296	47	1,228	49	1,150	53	1,055	962	860
	Med	2.5	1,212	50	1,182	51	1,138	53	1,091	55	1,019	59	944	871	769
	Med-Lo	2	1,002	60	978	62	956	63	921	66	878	69	825	738	647
	Low	1.5	813	74	805	75	790	76	759	80	726	83	689	644	605
GCH95 0704CX	High	4	1,755	34	1,674	36	1,632	37	1,510	40	1,423	42	1,325	1,241	1,116
	Med	3.5	1,656	36	1,585	38	1,536	39	1,429	42	1,355	45	1,268	1,145	1,059
	Med-Lo	3	1,551	39	1,488	41	1,427	42	1,353	45	1,290	47	1,195	1,100	1,017
	Low	2.5	1,286	47	1,258	48	1,241	49	1,185	51	1,112	54	1,067	983	886
GCH95 0904CX	High	4	1,734	46	1,652	49	1,578	51	1,508	53	1,413	57	1,336	1,248	1,154
	Med	3.5	1,642	49	1,558	52	1,487	54	1,418	57	1,336	60	1,243	1,164	1,039
	Med-Lo	3	1,522	53	1,458	55	1,396	58	1,321	61	1,253	64	1,182	1,101	986
	Low	2.5	1,287	63	1,244	65	1,184	68	1,148	70	1,098	73	1,034	953	849
GCH95 0905DX	High	5	2,189	37	2,109	38	2,025	40	1,948	41	1,862	43	1,757	1,644	1,537
	Med	4	1,885	43	1,831	44	1,776	45	1,711	47	1,637	49	1,539	1,453	1,346
	Med-Lo	3.5	1,665	48	1,627	50	1,584	51	1,524	53	1,462	55	1,400	1,323	1,220
	Low	3	1,474	55	1,440	65	1,401	57	1,356	59	1,310	61	1,255	1,193	1,109
GCH9 1155DX	High	5	2,134	46	2,103	47	2,029	48	1,941	51	1,906	51	1,818	1,733	1,625
	Med	4	1,678	58	1,643	60	1,643	60	1,577	62	1,527	64	1,489	1,423	1,339
	Med-Lo	3.5	1,453	68	1,440	68	1,426	69	1,363	72	1,349	73	1,314	1,253	1,205
	Low	3	1,259	78	1,239	79	1,220	80	1,181	83	1,159	85	1,118	1,082	1,015

<sup>1</sup> @0.5" ESP

**NOTES:**

- CFM in chart is without filter(s). Filters do not ship with this furnace, but must be provided by the installer. If the furnace requires two return filters, this chart assumes both filters are installed.
- All furnaces ship as high-speed cooling and medium-speed heating. Installer must adjust blower cooling and heating speed as needed.
- For most jobs, about 400 CFM per ton when cooling is desirable.
- INSTALLATION IS TO BE ADJUSTED TO OBTAIN TEMPERATURE RISE WITHIN THE RANGE SPECIFIED ON THE RATING PLATE.
- This chart is for information only. For satisfactory operation, external static pressure should not exceed value shown on the rating plate.
- The above chart is for U.S. furnaces installed at 0-2000 feet. At higher altitudes, a properly derated unit will have approximately the same temperature rise at a particular CFM, while ESP at the CFM will be lower.



# GMH95 Wiring Diagram with Honeywell Valve

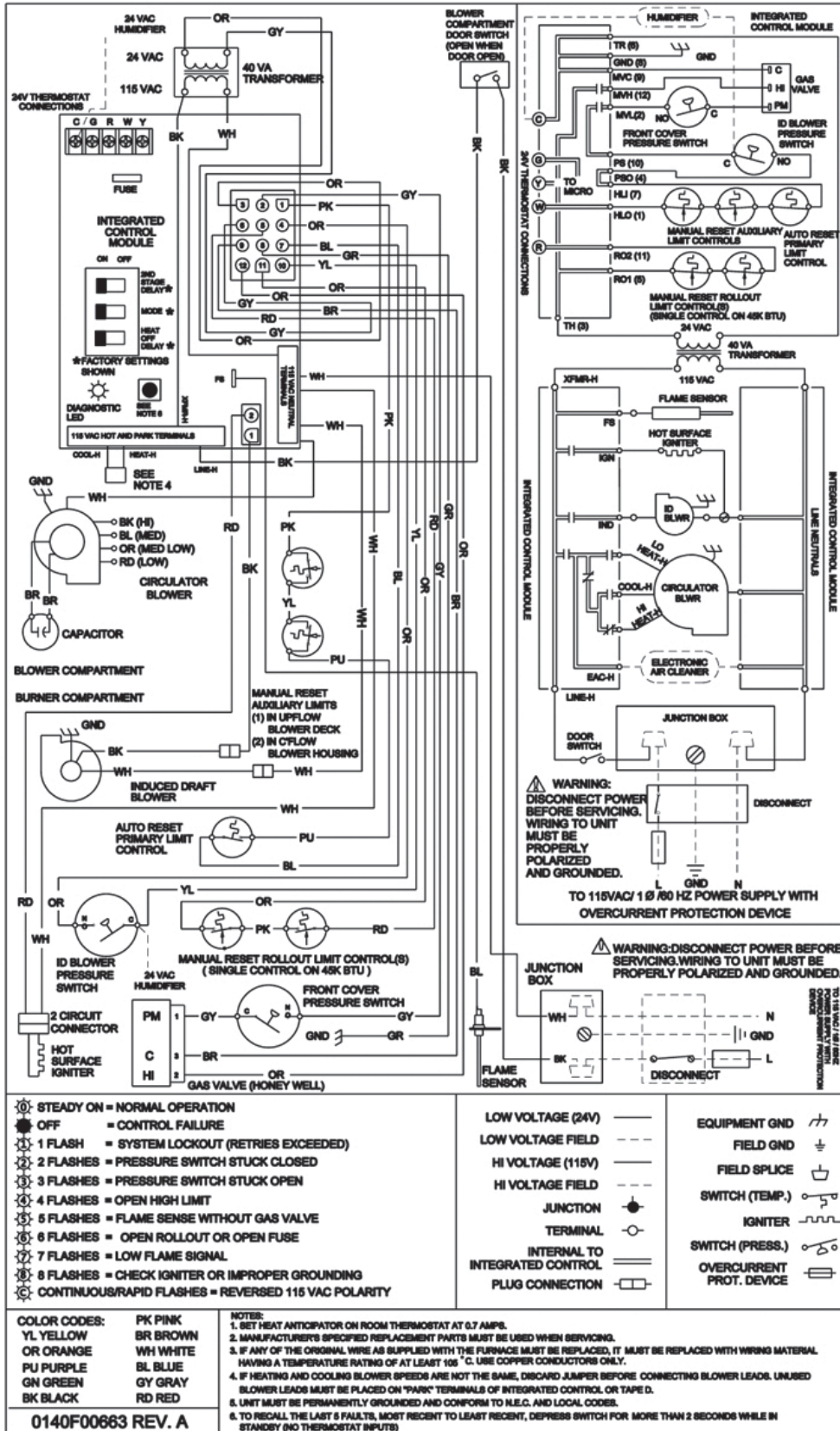

High Voltage: Disconnect all power before servicing or installing this unit. Multiple power sources may be present. Failure to do so may cause property damage, personal injury, or death.

**WARNING**

DISCONNECT POWER BEFORE SERVICING. WIRING TO UNIT MUST BE PROPERLY POLARIZED AND GROUNDED.

Wiring is subject to change. Always refer to the wiring diagram or the unit for the most up-to-date wiring.

# GCH95/GCH9115 WIRING DIAGRAM WITH HONEYWELL VALVE

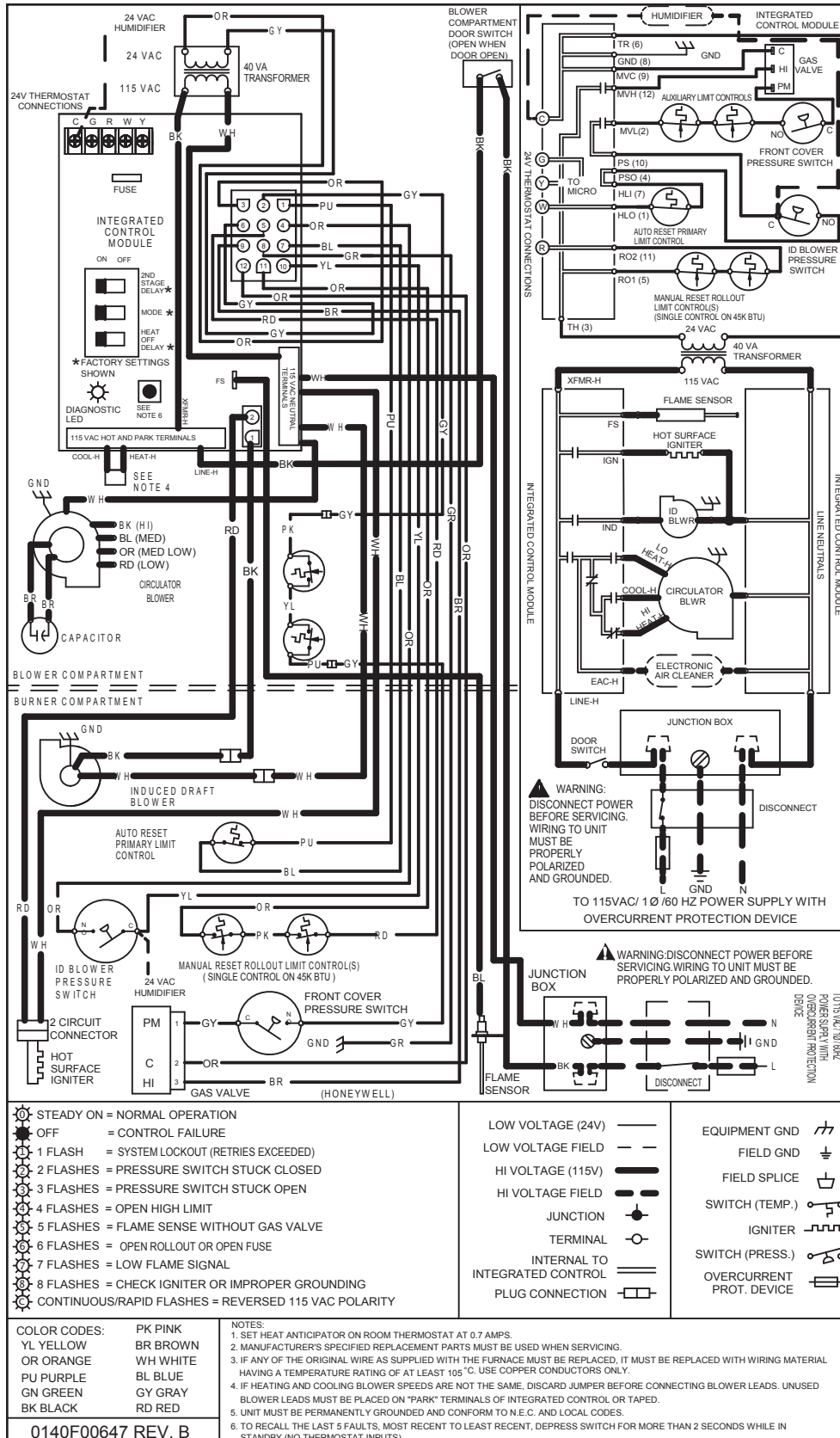

High Voltage: Disconnect all power before servicing or installing this unit. Multiple power sources may be present. Failure to do so may cause property damage, personal injury, or death.

**WARNING**

Wiring is subject to change. Always refer to the wiring diagram or the unit for the most up-to-date wiring.



# GCH95 WIRING DIAGRAM WITH WHITE-RODGERS VALVE

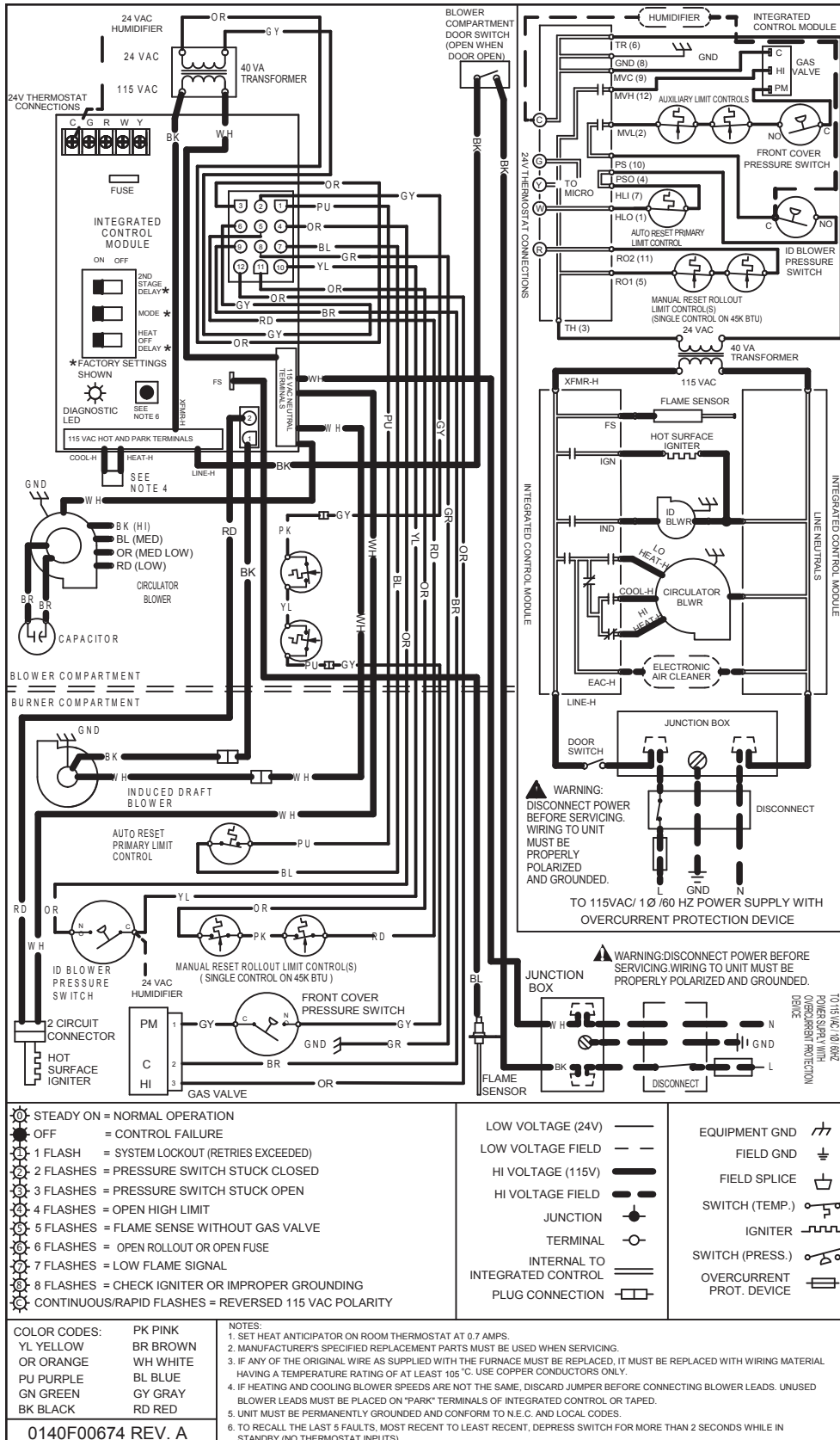

High Voltage: Disconnect all power before servicing or installing this unit. Multiple power sources may be present. Failure to do so may cause property damage, personal injury, or death.

**WARNING**

Wiring is subject to change. Always refer to the wiring diagram or the unit for the most up-to-date wiring.

## DUAL\$AVER CONFIGURATION & OPERATION

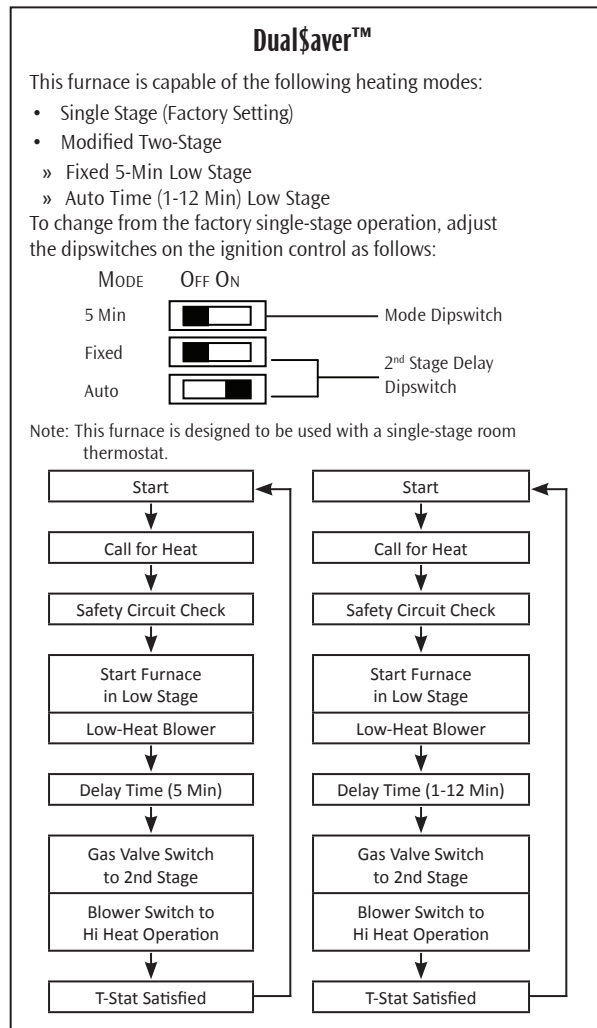

## THERMOSTATS

MODEL	DESCRIPTION
CHT18-60	Cooling/Heating, Mechanical
CH70TG	Cooling/Heating, Digital, Non-programmable
CHSATG	Cooling/Heating, Mechanical
H20TWR	Heating Only, Mechanical

ACCESSORIES — GMH95

ACCESSORY	DESCRIPTION	GMH95 0453BXA	GMH95 0703BXA	GMH95 0704CXA	GMH95 0904CXA	GMH95 0905DXA	GMH95 1155DXA
LPM-05	LP Conversion Kit (Springs & Orifice) <sup>1</sup>	√	√	√	√	√	√
LPM-06	LP Conversion Kit (Springs & Orifice) <sup>2</sup>	√	√	√	√	√	√
LPLP01	LP Gas Low-Pressure Kit	√	√	√	√	√	√
GSAS	Electronic Air Cleaners (-10, -11, -12, -18)	√	√	√	√	√	√
GMU	Media Air Cleaners (1620, 2020, 1625, 2025)	√	√	√	√	√	√
HANG11	High Altitude Natural Gas Kit	1	1	1	1	1	1
HANG12	High Altitude Natural Gas Kit	2	2	2	2	2	2
HALP10	High Altitude LP Gas Kit	3	3	3	3	3	3
HAPS27	High Altitude Pressure Switch Kit	3	3	3	3	3	3
FTK04	Twinning Kit	√	√	√	√	√	√
EFR01	External Filter Rack	√	√	√	√	√	√
DCVK-20	Horizontal/Vertical Concentric Vent Kit (2")	√	√	---	---	---	---
DCVK-30	Horizontal/Vertical Concentric Vent Kit (3")	√	√	√	√	√	√
0170K00000S	Flush-mount Vent Kit	√	√	√	√	√	√

<sup>1</sup> White-Rodgers valves only

<sup>2</sup> White-Rodgers and Honeywell valves

√ Indicates accessories available for this model

1 Indicates 7,001' to 9,000' altitude

2 Indicates 9,001' to 11,000' altitude

3 Indicates 7,001' to 11,000' altitude

NOTES

- All installations above 7,000' require a pressure switch change. For installation in Canada, furnaces are certified only to 4,500'.
- Downflow Floor base: When the GCH9 model is installed directly on a wood floor, a downflow floor base must be used. Those model numbers are: CFB17, CFB21 and CFB24.

## ACCESSORIES — GCH95/9

ACCESSORY	DESCRIPTION	GCH95 0453BXA	GCH95 0703BXA	GCH95 0704CXA	GCH95 0904CXA	GCH95 0905DXA	GCH9 1155DXA
LPM-05	LP Conversion Kit (Springs & Orifice) <sup>1</sup>	√	√	√	√	√	√
LPM-06	LP Conversion Kit (Springs & Orifice) <sup>2</sup>	√	√	√	√	√	√
LPLP01	LP Gas Low-Pressure Kit						√
GSAS	Electronic Air Cleaners (-10, -11, -12, -18)	√	√	√	√	√	√
GMU	Media Air Cleaners (1620, 2020, 1625, 2025)	√	√	√	√	√	√
HANG11	High Altitude Natural Gas Kit	1	1	1	1	1	1
HANG12	High Altitude Natural Gas Kit	2	2	2	2	2	2
HALP10	High Altitude LP Gas Kit	3	3	3	3	3	3
HAPS27	High Altitude Pressure Switch Kit	3	3	3	3	3	3
EFR01	External Filter Rack	√	√	√	√	√	√
DCVK-20	Horizontal/Vertical Concentric Vent Kit (2")	√	√	---	---	---	---
DCVK-30	Horizontal/Vertical Concentric Vent Kit (3")	√	√	√	√	√	√
0170K00000S	Flush-mount Vent Kit	√	√	√	√	√	√

<sup>1</sup> White-Rodgers valves only

<sup>2</sup> White-Rodgers and Honeywell valves

√ Indicates accessories available for this model

1 Indicates 7,001' to 9,000' altitude

2 Indicates 9,001' to 11,000' altitude

3 Indicates 7,001' to 11,000' altitude

### NOTES

- All installations above 7,000' require a pressure switch change. For installation in Canada, furnaces are certified only to 4,500'.
- Downflow Floor base: When the GCH9 model is installed directly on a wood floor, a downflow floor base must be used. Those model numbers are: CFB17, CFB21 and CFB24.

NOTES



Goodman Manufacturing Company, L.P., reserves the right to discontinue, or change at any time, specifications or designs without notice or without incurring obligations. © 2011 • Goodman Manufacturing Company, L.P. • Houston, Texas • Printed in the USA.

