



# DAIKIN FTQ SERIES HEATING AND COOLING SYSTEMS

MULTI-POSITIONAL AIR HANDLER  
Up to 16 SEER / Up to 10.4 HSPF / Up to 12.5 EER

## Feel the difference

Designed for superior heating capacity in low ambient conditions, Daikin FTQ Ducted systems provide comfortable heating operation down to -4° F (-20° C), with up to 100% capacity available at temperatures as low as -4° F (-20° C) on systems up to 3 tons. This capability can help simplify installation cost and operational cost by eliminating the need for additional supplemental electric heat. As a year round solution, the Daikin FTQ Ducted systems also operate in Cooling mode from 23° F (-5° C) to 122° F (50° C).

## Hear the difference

Utilizing inverter technology to maintain comfort settings, Daikin systems most often operate at low speeds with indoor sound levels as low as 38 decibels (dB) and outdoor sound levels as low as 57 dB.

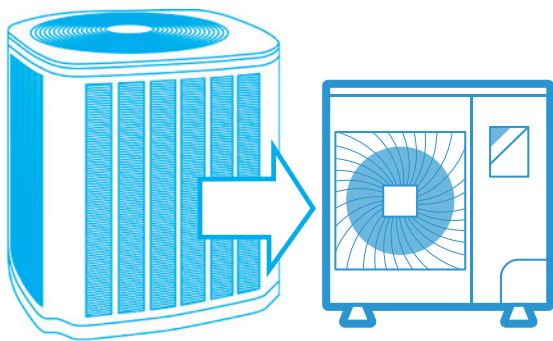

## See the difference

A Daikin inverter system is designed for installation where space is limited, such as with zero lot lines, or limited to roof, wall or terrace areas. The compact and lightweight design, when compared to traditional solutions allows the Daikin inverter system to be used in homes with the strictest of limitations with relative ease.

Sound levels as low as:

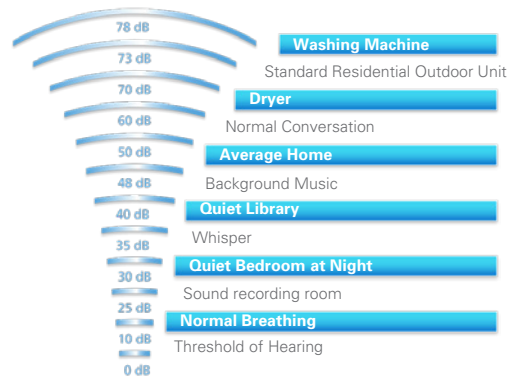

**100% heating capacity at -4° F (-20° C)  
 for systems up to 3 tons  
 (heat pump only)**

## New drain pan

Newly designed drain pan on outdoor unit to help prevent condensate from freezing and causing damage to the fan and coil.



Single fan drain pan

Double fan drain pan

## Knowledge is power

In general, system performance is measured by a higher Seasonal Energy Efficiency Ratio (SEER) and Energy Efficiency Ratio (EER). Higher ratings mean lower operating costs. Similarly, a higher rated Heating Seasonal Performance Factor (HSPF) and Coefficient of Performance (COP) means a more efficient air-source heat pump.

## Why is it important?

The COP of a heat pump is the ratio of:  $COP = \frac{\text{energy out}}{\text{energy in}}$ . When the COP is >1, the result is a system providing more heating energy than energy consumed. As the COP increases, the higher the efficiency — resulting in lower utility costs.

	Up to	
<b>16.0</b>	<b>12.5</b>	
<b>SEER</b>	<b>EER</b>	
<b>W</b>	<b>3.7</b>	
<b>HSPF</b>	<b>COP</b>	(Coefficient of Performance)

Inverter Ducted Heat Pump  
 Efficiency ratings



# FTQ Series

## Standard features

- » Full multi-position air handler capable of upflow, downflow\*\*, horizontal left, or horizontal right configurations
- » Wide lineup of electric heat (field installed) options from 3kW to 19W
- » Designed with less than 2% air leakage when tested in accordance with ASHRAE standard 193
- » 100% heating capacity at low ambient temperatures as low as -4° F with no electrical heat (for systems up to 3 tons)

## Time-saving installation

- » Available without optional factory installed disconnect (Built to order — model FTQ\_TAVJUA)
- » At 45" tall and only 17.5" wide, up to 3 tons, the FTQ can be installed in tight spaces
- » Easily integrate third party accessories such as a humidifier or economizer with on-board contacts
- » Gravity-fed drain connection
- » Designed for zero clearance on three sides and only 24" clearance on the front for service

\*\*Downflow requires field installed optional downflow accessory

## Outdoor unit features:



**Anti-Corrosion Treatment on Heat Exchanger**



**Auto-Restart** – The unit memorizes the operation mode, airflow and temperature settings. Should there be a power failure when the unit is in operation, it will automatically return to the same operating conditions when the power is restored.



**Self-Diagnosis** – In the event that a problem develops with the unit, malfunction codes can be displayed on the liquid crystal panel of the remote control for fast and easy fault diagnosis.

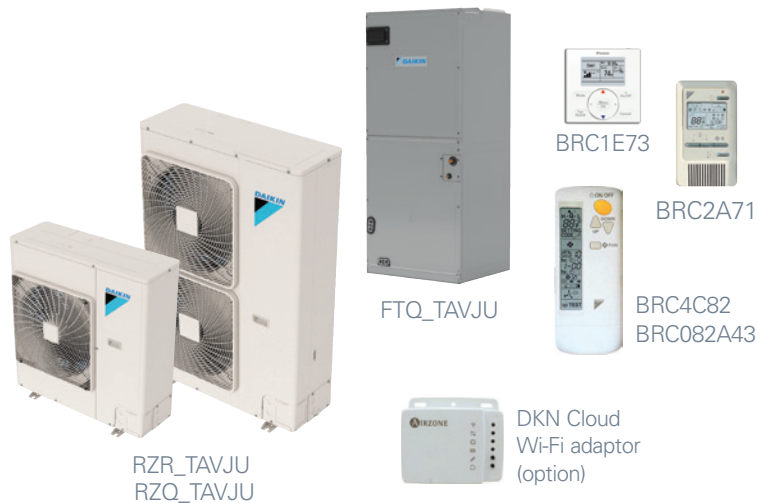



## Comfort

We offer a wide range of products, and always provide you with the ideal solution, whether for an apartment, condo or a house. Our units are whisper quiet and, with their specially designed airflow pattern, they create your ideal indoor climate.

Daikin units are designed to include features that let you create your own unique ecosystem. From the wide-angle louver design to the auto-swing and comfortable mode controller settings, effective heating and cooling is ensured throughout the space.

## Smart inverter technology

Integrated with an inverter variable-speed compressor, Daikin systems deliver the capacity required to maintain desired room conditions, typically reducing energy consumption by up to 30% or more (compared to traditional fixed-speed ducted systems). This technology minimizes temperature fluctuations and provides continuous cooling and heating comfort.

## Energy efficiency

Our products are designed to be highly efficient all year round, and their low energy consumption is reflected in low energy bills for you.

## Flexibility

With space saving design, wide operation range and long pipe lengths you have maximum flexibility in your design to suit your needs.

## Reliability

Daikin products are renowned for their reliability. And you can rely on service to match, with industry leading warranties.\*



\* Complete warranty details available from your local dealer or at [www.daikincomfort.com](http://www.daikincomfort.com).

# FTQ SERIES HEATING AND COOLING SYSTEMS MULTI-POSITION AIR HANDLING UNITS

Model	Indoor Unit		FTQ18TAVJUD		FTQ24TAVJUD		FTQ30TAVJUD		FTQ36TAVJUD		FTQ42TAVJUD		FTQ48TAVJUD				
	Indoor Unit (Without Factory Disconnect)		FTQ18TAVJUA		FTQ24TAVJUA		FTQ30TAVJUA		FTQ36TAVJUA		FTQ42TAVJUA		FTQ48TAVJUA				
	Outdoor Unit (Cooling Only)		RZR18TAVJU		RZR24TAVJU		RZR30TAVJU		RZR36TAVJU		RZR42TAVJU		RZR48TAVJU				
	Outdoor Unit (Heat Pump)		RZQ18TAVJU		RZQ24TAVJU		RZQ30TAVJU		RZQ36TAVJU		RZQ42TAVJU		RZQ48TAVJU				
		Cooling		Heating*		Cooling		Heating*		Cooling		Heating*		Cooling		Heating*	
Capacity Rated		Btu/h		18,000	20,000	24,000	27,000	30,000	34,000	36,000	40,000	42,000	47,000	48,000	54,000		
COP Rated*		3.5		3.3		3.7		3.4		3.6		3.4					
EER Rated		12.5		10.3		12.5		11.3		11		9.5					
SEER		15.5		15.2		16		15.3		16		14.8					
HSPF*		8.6		9.4		10.4		9.5		9		9					
Piping Connections	Liquid	in. (mm)	Ø 3/8 (Ø 9.5)														
	Gas		Ø 5/8 (Ø 15.8)														
	Drain		Ø 1 (Ø 25.4)														
Max. Interunit Piping Length		164 (50)						230 (70)									
Max. Interunit Height Difference		98.4 (30)															
Chargeless		15 (4.5)															
FTQ Additional Charge†		0.1						0.71						1.05			
Amount of Additional Charge of Refrigerant		0.036 (0.0536)															
Operating Range - Cooling		23° - 122°F (-5 - 50° C)															
Operating Range - Heating*		-4° - 60°F (-20 - 15.5° C)															
Indoor Unit		FTQ18TAVJUD / FTQ18TAVJUA		FTQ24TAVJUD / FTQ24TAVJUA		FTQ30TAVJUD / FTQ30TAVJUA		FTQ36TAVJUD / FTQ36TAVJUA		FTQ42TAVJUD / FTQ42TAVJUA		FTQ48TAVJUD / FTQ48TAVJUA					
External Static Pressure		In. wg (Pa)		0.9 (224)													
Airflow Rate	H	cfm (m³/min)	600 (17.0)		800 (22.7)		1000 (28.3)		1050 (29.7)		1400 (39.6)		1520 (43.1)				
	M		510 (14.4)		680 (19.3)		850 (24.1)		900 (25.5)		1190 (32.7)		1290 (36.5)				
	L		420 (11.9)		560 (15.9)		700 (19.8)		750 (21.2)		980 (27.8)		1060 (30)				
Fan		Type		Sirocco Fan													
Air Direction Control		N/A															
Air Filter		N/A															
Dimensions (H x W x D)		in. (mm)		45 x 17.5 x 21 (1143 x 445 x 533)						53.4 x 21 x 21 (1357 x 533 x 533)							
Weight		Lbs (kg)		115 (52.2)						140 (63.5)		150 (68)					
Sound Pressure Level (H / M / L / SL)		dB(A)		53 / 50 / 47		45 / 41 / 38		52 / 48 / 44		52 / 48 / 44		54 / 50 / 46		54 / 50 / 46			
Outdoor Unit		RZR18TAVJU / RZQ18TAVJU		RZR24TAVJU / RZQ24TAVJU		RZR30TAVJU / RZQ30TAVJU		RZR36TAVJU / RZQ36TAVJU		RZR42TAVJU / RZQ42TAVJU		RZR48TAVJU / RZQ48TAVJU					
Compressor		Motor Output		W		1,900		3,500									
Refrigerant		Type		R-410A													
		Charge		Lbs (kg)		6.4 (2.9)		7.9 (3.6)									
Airflow Rate		H		cfm (m³/min)		2,682 (76)		3,741 (106)									
Dimensions (H x W x D)		in. (mm)		39 x 37 x 12-5/8 (990 x 940 x 320)						52-15/16 x 35-7/16 x 12-5/8 (1345 x 900 x 320)							
Weight		Lbs (kg)		172 (78)						225 (102)							
Sound Pressure Level		H		dB(A)		58	61*	58	61*	57	59*	57	59*	57	59*	57	59*

\*Applicable to heat pump models only, refer to installation manual for more details.

† Additional charge needed regardless of piping length. Refer to installation manual.

## AIR ADJUSTMENT GRILLE

KPW5E112	RZQ18TAVJU, RZQ24TAVJU, RZR18TAVJU, RZR24TAVJU
KPW5E80 (X2)	RZQ30TAVJU, RZQ36TAVJU, RZQ42TAVJU, RZQ48TAVJU, RZR30TAVJU, RZR36TAVJU, RZR42TAVJU, RZR48TAVJU

## Electric Heater Options

### ELECTRICAL HEATER CAPACITY

Model Name	3kW	5kW	6kW	8kW	10kW	15kW	19kW
FTQ18TAVJUD/A	■	■	■	■	■		
FTQ24TAVJUD/A	■	■	■	■	■		
FTQ30TAVJUD/A	■	■	■	■	■		
FTQ36TAVJUD/A	■	■	■	■	■		
FTQ42TAVJUD/A		■	■	■	■	■	■
FTQ48TAVJUD/A		■	■	■	■	■	■

# FTQ SERIES MULTI-POSITION AIR HANDLING UNITS HEAT PUMP AND COOLING ONLY INSTALLATION

## Ease of installation

Connected by a pair of refrigerant lines, few electrical connections, and no ductwork, indoor and outdoor units can be easily installed in existing spaces with minor disruption and often in a single day's work. The compact and lightweight designs combined with piping lengths up to 230 ft. and minimal wiring allow installation with minimal time and costs.

## FTQ18/24/30/36/42/48/TAVJUD/A Installations Configurations

Designed for zero clearance on three sides and only 24" clearance on the front for service

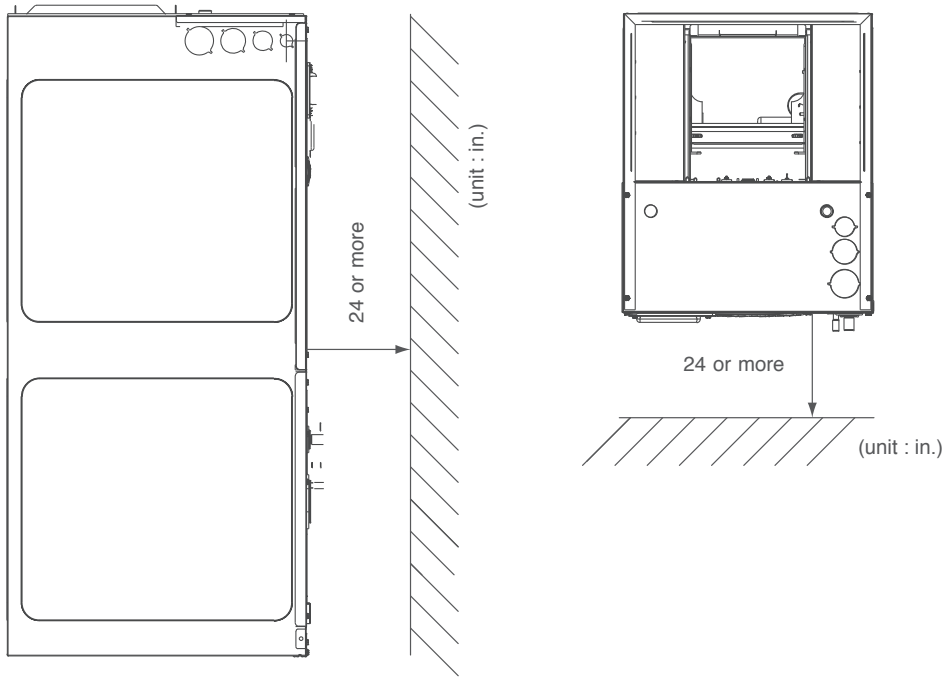

## RZQ18/24TAVJU Single-Fan Unit

Space required for installation (in.)

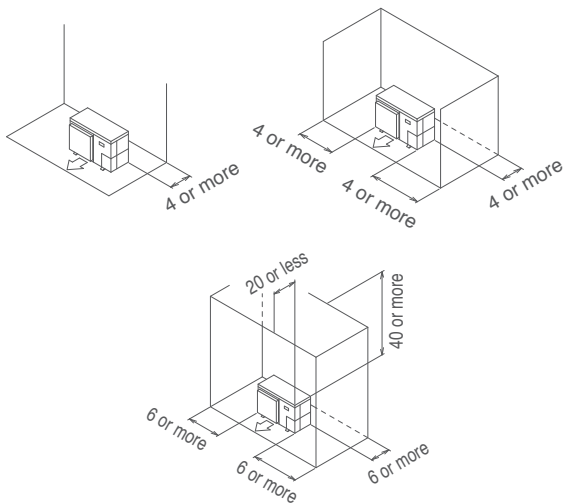

## RZQ30/36/42/48/TAVJU Double-Fan Unit

For double fan outdoor modules, the requirements are similar in some cases. Always refer to installation manuals for details.

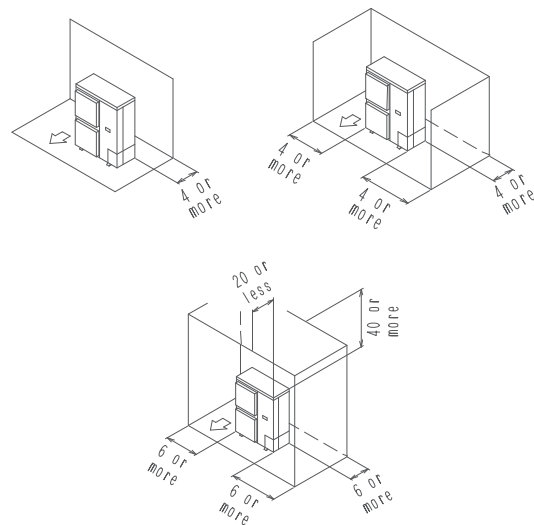



## About Daikin:

Daikin Industries, Ltd. (DIL) is a global Fortune 1000 company which celebrated its 90th anniversary in May 2014. The company is recognized as the largest HVAC (Heating, Ventilation, Air Conditioning) manufacturers in the world. DIL is primarily engaged in developing indoor comfort systems and refrigeration products for residential, commercial and industrial applications. Its consistent success is derived, in part, from a focus on innovative, energy-efficient and premium quality indoor climate and comfort management solutions.



## WARNINGS:

- » Always use a licensed installer or contractor to install this product. Do not try to install the product yourself. Improper installation can result in water or refrigerant leakage, electrical shock, fire or explosion.
- » Use only those parts and accessories supplied or specified by Daikin. Ask a licensed contractor to install those parts and accessories. Use of unauthorized parts and accessories or improper installation of parts and accessories can result in water or refrigerant leakage, electrical shock, fire or explosion.
- » Read the User's Manual carefully before using this product. The User's Manual provides important safety instructions and warnings. Be sure to follow these instructions and warnings.
- » For any inquiries, contact your local Daikin sales office.



## ADDITIONAL INFORMATION

Before purchasing this appliance, read important information about its estimated annual energy consumption, yearly operating cost, or energy efficiency rating that is available from your retailer.

Daikin and its design are trademarks owned by Daikin.

