

DAIKIN

INSTALLATION MANUAL

SPLIT SYSTEM

HEAT PUMP

MODELS

Air Handling Unit

FTQ18PBVJU

FTQ24PBVJU

FTQ30PBVJU

FTQ36PBVJU

FTQ42PBVJU

English

Français

Español

Read these instructions carefully before installation.
Keep this manual in a handy place for future reference.
This manual should be left with the equipment owner.

Lire soigneusement ces instructions avant l'installation.
Conserver ce manuel à portée de main pour référence ultérieure.
Ce manuel doit être donné au propriétaire de l'équipement.

Lea cuidadosamente estas instrucciones antes de instalar.
Guarde este manual en un lugar a mano para leer en caso de tener alguna duda.
Este manual debe permanecer con el propietario del equipo.

CONTENTS

1. SAFETY CONSIDERATIONS	1
2. BEFORE INSTALLATION.....	3
3. SELECTING INSTALLATION SITE	4
4. PREPARATIONS BEFORE INSTALLATION AND INSTALLATION.....	5
5. REFRIGERANT PIPING WORK	6
6. DRAIN PIPING WORK.....	8
7. INSTALLING THE DUCT.....	9
8. ELECTRIC WIRING WORK	9
9. WIRING EXAMPLE	10
10. FIELD SETTING AND TEST RUN	13

1. SAFETY CONSIDERATIONS

Read these “SAFETY CONSIDERATIONS for Installation” carefully before installing an air conditioner or heat pump. After completing the installation, make sure that the unit operates properly during the startup operation.

Instruct the customer on how to operate and maintain the unit. Inform customers that they should store this Installation Manual with the Operation Manual for future reference.

Always use a licensed installer or contractor to install this product. Improper installation can result in water or refrigerant leakage, electrical shock, fire, or explosion.

This air conditioner comes under the term “appliances not accessible to the general public”.

Meanings of **DANGER**, **WARNING**, **CAUTION**, and **NOTE** Symbols:

 **DANGER**..... Indicates an imminently hazardous situation which, if not avoided, will result in death or serious injury.

 **WARNING**..... Indicates a potentially hazardous situation which, if not avoided, could result in death or serious injury.

 **CAUTION**..... Indicates a potentially hazardous situation which, if not avoided, may result in minor or moderate injury. It may also be used to alert against unsafe practices.

 **NOTE**..... Indicates situations that may result in equipment or property-damage accidents only.

DANGER

- Refrigerant gas is heavier than air and replaces oxygen. A massive leak can lead to oxygen depletion, especially in basements, and an asphyxiation hazard could occur leading to serious injury or death.

- Do not ground units to water pipes, gas pipes, telephone wires, or lightning rods as incomplete grounding can cause a severe shock hazard resulting in severe injury or death. Additionally, grounding to gas pipes could cause a gas leak and potential explosion causing severe injury or death.
- If refrigerant gas leaks during installation, ventilate the area immediately. Refrigerant gas may produce toxic gas if it comes in contact with fire. Exposure to this gas could cause severe injury or death.
- After completing the installation work, check that the refrigerant gas does not leak throughout the system.
- Do not install unit in an area where flammable materials are present due to risk of explosions that can cause serious injury or death.
- Safely dispose all packing and transportation materials in accordance with federal/state/local laws or ordinances. Packing materials such as nails and other metal or wood parts, including plastic packing materials used for transportation may cause injuries or death by suffocation.

WARNING

- All phases of the field-installation, including, but not limited to, electrical, piping, safety, etc. must be in accordance with manufacturer’s instructions and must comply with national, state, provincial and local codes.
- Only qualified personnel must carry out the installation work. Installation must be done in accordance with this installation manual. Improper installation may result in water leakage, electric shock, or fire.
- When installing the unit in a small room, take measures to keep the refrigerant concentration from exceeding allowable safety limits. Excessive refrigerant leaks, in the event of an accident in a closed ambient space, can lead to oxygen deficiency.
- Use only specified accessories and parts for installation work. Failure to use specified parts may result in water leakage, electric shocks, fire, or the unit falling.
- Install the air conditioner or heat pump on a foundation strong enough that it can withstand the weight of the unit. A foundation of insufficient strength may result in the unit falling and causing injuries.
- Take into account strong winds, typhoons, or earthquakes when installing. Improper installation may result in the unit falling and causing accidents.
- Make sure that a separate power supply circuit is provided for this unit and that all electrical work is carried out by qualified personnel according to local, state, and national regulations. An insufficient power supply capacity or improper electrical construction may lead to electric shocks or fire.

- Make sure that all wiring is secured, that specified wires are used, and that no external forces act on the terminal connections or wires. Improper connections or installation may result in fire.
- When wiring, position the wires so that the control box cover can be securely fastened. Improper positioning of the control box cover may result in electric shocks, fire, or the terminals overheating.
- Before touching electrical parts, turn off the unit.
- It is recommended to install a ground fault circuit interrupter if one is not already available. This helps prevent electrical shocks or fire.
- Securely fasten the outdoor unit terminal cover (panel). If the terminal cover/panel is not installed properly, dust or water may enter the outdoor unit causing fire or electric shock.
- When installing or relocating the system, keep the refrigerant circuit free from substances other than the specified refrigerant (R410A) such as air. Any presence of air or other foreign substance in the refrigerant circuit can cause an abnormal pressure rise or rupture, resulting in injury.
- Do not change the setting of the protection devices. If the pressure switch, thermal switch, or other protection device is shorted and operated forcibly, or parts other than those specified by Daikin are used, fire or explosion may occur.
- Heat exchanger fins are sharp enough to cut. To avoid injury wear glove or cover the fins when working around them.

 CAUTION

- Do not touch the switch with wet fingers. Touching a switch with wet fingers can cause electric shock.
- Do not allow children to play on or around the unit to prevent injury.
- Do not touch the refrigerant pipes during and immediately after operation as the refrigerant pipes may be hot or cold, depending on the condition of the refrigerant flowing through the refrigerant piping, compressor, and other refrigerant cycle parts. Your hands may suffer burns or frostbite if you touch the refrigerant pipes. To avoid injury, give the pipes time to return to normal temperature or, if you must touch them, be sure to wear proper gloves.
- Install drain piping to proper drainage. Improper drain piping may result in water leakage and property damage.
- Insulate piping to prevent condensation.
- Be careful when transporting the product.
- Do not turn off the power immediately after stopping operation. Always wait for at least 5 minutes before turning off the power. Otherwise, water leakage may occur.

- Do not touch the refrigerant pipes during and immediately after operation as the refrigerant pipes may be hot or cold, depending on the condition of the refrigerant flowing through the refrigerant piping, compressor, and other refrigerant cycle parts. Your hands may suffer burns or frostbite if you touch the refrigerant pipes. To avoid injury, give the pipes time to return to normal temperature or, if you must touch them, be sure to wear proper gloves.
- Do not use a charging cylinder. Using a charging cylinder may cause the refrigerant to deteriorate.
- Refrigerant R410A in the system must be kept clean, dry, and tight.
 - (a) Clean and Dry -- Foreign materials (including mineral oils such as SUNISO oil or moisture) should be prevented from getting into the system.
 - (b) Tight -- R410A does not contain any chlorine, does not destroy the ozone layer, and does not reduce the earth's protection against harmful ultraviolet radiation. R410A can contribute to the greenhouse effect if it is released. Therefore take proper measures to check for the tightness of the refrigerant piping installation. Read the chapter Refrigerant Piping work and follow the procedures.
- Since R410A is a blend, the required additional refrigerant must be charged in its liquid state. If the refrigerant is charged in a state of gas, its composition can change and the system will not work properly.
- The indoor unit is for R410A. See the catalog for indoor models that can be connected. Normal operation is not possible when connected to other units.
- Remote controller transmitting distance can be shorter than expected in rooms with electronic fluorescent lamps (inverter or rapid start types). Install the indoor unit far away from fluorescent lamps as much as possible.
- Install in a machine room that is free of moisture. The unit is designed for indoor use.
- Indoor units are for indoor installation only. Outdoor units can be installed either outdoors or indoors. This unit is for indoor use.
- Do not install the air conditioner or heat pump in the following locations:
 - (a) Where a mineral oil mist or oil spray or vapor is produced, for example, in a kitchen. Plastic parts may deteriorate and fall off or result in water leakage.
 - (b) Where corrosive gas, such as sulfuric acid gas, is produced. Corroding copper pipes or soldered parts may result in refrigerant leakage.
 - (c) Near machinery emitting electromagnetic waves. Electromagnetic waves may disturb the operation of the control system and cause the unit to malfunction.
 - (d) Where flammable gas may leak, where there is carbon fiber, or ignitable dust suspension in the air, or where volatile flammables such as thinner or gasoline are handled. Operating the unit in such conditions can cause a fire.

- Take adequate measures to prevent the outdoor unit from being used as a shelter by small animals. Small animals making contact with electrical parts can cause malfunctions, smoke, or fire. Instruct the customer to keep the area around the unit clean.

NOTE

- Install the power supply and control wires for the indoor and outdoor units at least 3.5 feet away from televisions or radios to prevent image interference or noise. Depending on the radio waves, a distance of 3.5 feet may not be sufficient to eliminate the noise.
- In a domestic environment this product may cause radio interference in which case the user may be required to take adequate measures.
- Dismantling the unit, treatment of the refrigerant, oil and additional parts must be done in accordance with the relevant local, state, and national regulations.
- Do not use the following tools that are used with conventional refrigerants: gauge manifold, charge hose, gas leak detector, reverse flow check valve, refrigerant charge base, vacuum gauge, or refrigerant recovery equipment.
- If the conventional refrigerant and refrigerator oil are mixed in R410A, the refrigerant may deteriorate.
- This air conditioner or heat pump is an appliance that should not be accessible to the general public.
- As design pressure is 478 psi, the wall thickness of field-installed pipes should be selected in accordance with the relevant local, state, and national regulations.

2. BEFORE INSTALLATION

WARNING

- Entrust installation to the place of purchase or a qualified serviceman. Improper installation could lead to leaks and, in worse cases, electric shock or fire.
- Use of unspecified parts could lead to the unit falling, leaks and, in worse cases, electric shock or fire.

NOTE

- Be sure to read this manual before installing the indoor unit.
- Be sure to mount an air filter (part to be procured in the field) in the suction air passage in order to prevent water leaking, etc.

The accessories needed for installation must be retained in your custody until the installation work is completed. Do not discard them.

1. Decide upon a line of transport.
2. Leave the unit inside its packaging while moving, until reaching the installation site. Where unpacking is unavoidable, use a sling of soft material or protective plates together with a rope when lifting, to avoid damage or scratches to the unit.

Be sure to check the type of R410A refrigerant to be used before installing the unit.

(Using an incorrect refrigerant will prevent normal operation of the unit.)





For the installation of an outdoor unit, refer to the installation manual attached to the outdoor unit.





2-1 PRECAUTIONS

- Be sure to instruct customers how to properly operate the unit (operating different functions, and adjusting the temperature) by having them carry out operations themselves while looking at the operation manual.
- Do not install in locations where the air contains high levels of salt such as that near the ocean and where voltage fluctuates greatly such as that in factories, or in vehicles or vessels.

2-2 ACCESSORIES

Check the following accessories are included with your unit.

Name	Clamp material (1)	Insulation tube	Metal clamp (4)	Drain hose (5)
Quantity	6 pcs.	1 set	1 pc.	1 pc.
Shape		 Small (2) 1 pc.  Large (3) 1 pc.		

Name	Insulation for fitting	Sealing pad	(Other) • Operation manual • Installation manual • Note sheet
Quantity	1 each	—	
Shape	 for liquid pipe (6)  for gas pipe (7)	 1 pc. Large (9)  2 pcs. Small (8)	

2-3 OPTIONAL ACCESSORIES

- This indoor unit requires one of the operation remote controls listed below.

Remote controller	
Wired type	BRC1E71

NOTE

- If you wish to use a remote controller that is not listed in Table 1, select a suitable remote controller after consulting catalogs and engineering data.

FOR THE FOLLOWING ITEMS, TAKE SPECIAL CARE DURING CONSTRUCTION AND CHECK AFTER INSTALLATION IS FINISHED.

a. Items to be checked after completion of work

Items to be checked	If not properly done, what is likely to occur.	Check
Are the indoor and outdoor unit fixed firmly?	The units may drop, vibrate or make noise.	
Was the installation of the outdoor unit completed?	The unit may malfunction or the components burn out.	
Is the gas leak test finished?	No cooling or heating.	
Is the unit fully insulated? (Refrigerant piping, drain piping, and duct)	Condensate water may drip.	
Dose drainage flow smoothly?	Condensate water may drip.	
Does the power supply voltage conform to the indication on the name plate?	The unit may malfunction or the components burn out.	
Are wiring and piping correct?	The unit may malfunction or the components burn out.	
Is the air conditioner or heat pump properly grounded?	Dangerous in case of current leakage.	
Is wiring size according to specifications?	The unit may malfunction or the components burn out.	
Is something blocking the air outlet or inlet of either the indoor or outdoor units?	No cooling or heating.	
Did you set the external static pressure?	No cooling or heating.	
Are refrigerant piping length and additional refrigerant charge noted down?	The refrigerant charge in the system is not clear.	
Did you check that no wiring connection screws were loose?	Electric shock or fire.	

Also review the "SAFETY CONSIDERATIONS".

b. Items to be checked at the time of delivery

Items to be checked	Check
Are you sure the control box lid, air filter, air inlet grille, and air outlet grille are mounted?	
Did you explain about operations while showing the operation manual to your customer?	
Did you deliver the operation manual along with the installation manual to the customer?	
Did you explain the customer the handling and cleaning methods of the field supplies (e.g., the air filter, air inlet grilles, and air outlet grille)?	
Did you deliver instruction manual, if any, for the field supplies to the customer?	

c. Points for explanation about operations

The items with **⚠** WARNING and **⚠** CAUTION marks in the operation manual are the items pertaining to possibilities for bodily injury and material damage in addition to the general usage of the product. Accordingly, it is necessary that you make a full explanation about the described contents and also ask your customers to read the operation manual.

3. SELECTING INSTALLATION SITE

⚠ CAUTION

- If you think the humidity inside the installation space might exceed 86°F and RH80%, reinforce the insulation on the unit body. Use glass wool or polyethylene foam as insulation so that the thickness is more than 2 in. and fits inside the installation space opening.

(1) Select an installation site where the following conditions are fulfilled and that meets with your customer's approval.

- Where optimum air distribution can be ensured.
- Where nothing blocks air passage.
- Where condensate can be properly drained.
- Where the supports are strong enough to bear the indoor unit weight.
- Where the false ceiling is not noticeably on an incline.
- Where sufficient clearance for maintenance and service can be ensured. (Refer to Fig. 1-1 and Fig. 1-2)
- Where piping between indoor and outdoor units is possible within the allowable limit. (Refer to the installation manual for the outdoor unit.)
- If the a return-air duct is not installed, carefully select the place and method of product installation so that air flow into the product will not be blocked.

If installed vertically

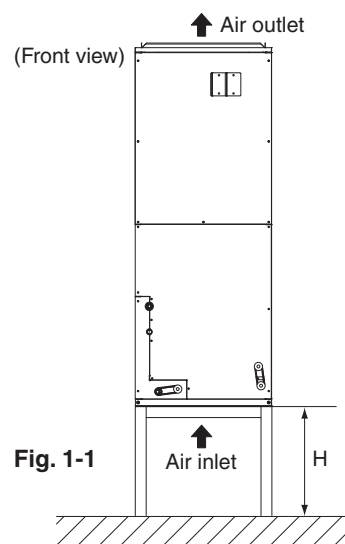
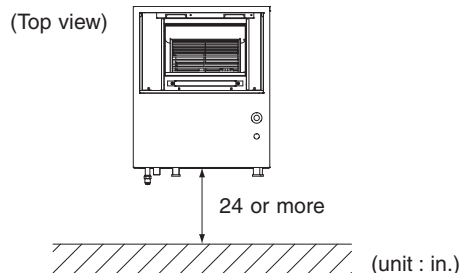

Fig. 1-1

If installed horizontally

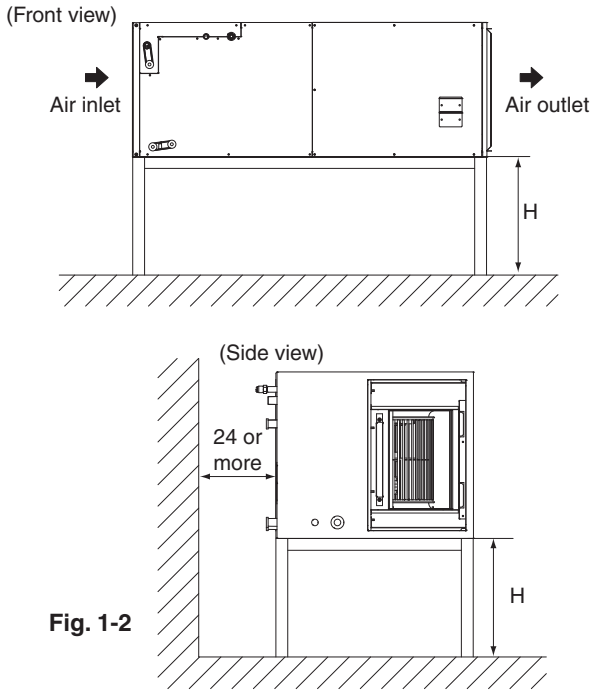

Fig. 1-2

⚠ WARNING

- When installing the unit horizontally, be sure to tilt the unit in the direction shown in Fig. 1-2. If the unit is tilted in any other way, water can leak.

- Ensure sufficient space for the bottom of the product (H dimensions) so that a downward slope of 1/100 can be maintained for drain piping, as described for the intake duct installation and in **“6. DRAIN PIPING WORK”**.

[PRECAUTION]

- Install the indoor and outdoor units, power supply wiring and connecting wires at least 3.5 ft. away from televisions or radios in order to prevent image interference or noise. (Depending on the radio waves, a distance of 3.3 ft. may not be sufficient to eliminate the noise.)
- If installing the wireless kit in a room with electronic fluorescent lighting (inverter or rapid start type), the remote controller’s transmission distance may be shortened. Indoor units should be installed as far away from fluorescent lighting as possible.

⚠ DANGER

- Do not install unit in an area where flammable materials are present due to the risk of an explosion resulting in serious injury or death.

⚠ WARNING

- If the supporting structural members are not strong enough to take the unit’s weight, the unit could fall out of place and cause serious injury.

4. PREPARATIONS BEFORE INSTALLATION AND INSTALLATION

- (1) When installing the product, refer to **“3. SELECTING INSTALLATION SITE”** and consider the product size as shown Fig. 2 and Table 1.



Fig. 2

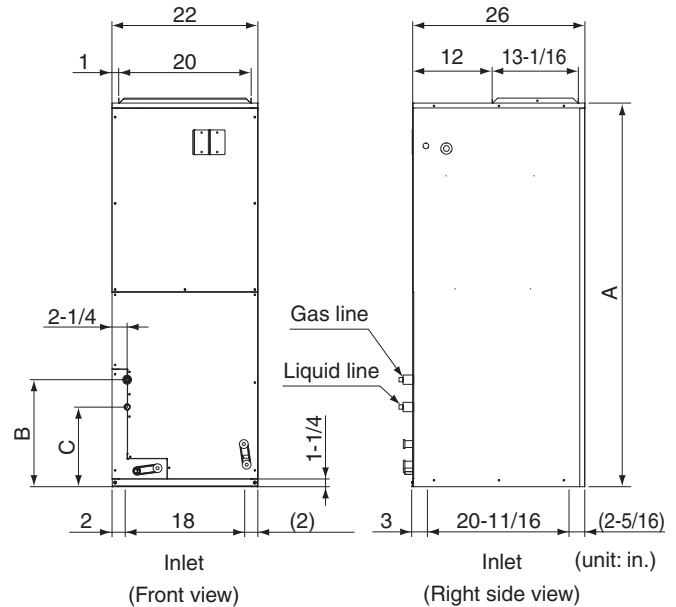

Table 1

	A	B	C
FTQ30 - 42	58-1/4	16-1/4	12-1/16
FTQ18 - 24	48-1/8	13-3/16	9-1/16

- (2) **Make sure the range of the unit’s external static pressure is not exceeded. (up to 0.5 in.W.C. at “HH” speed.)**

- (3) Condensation may form on the product during COOL operation. Be sure to provide (field supplied) and install a second drain pan.

If installed vertically

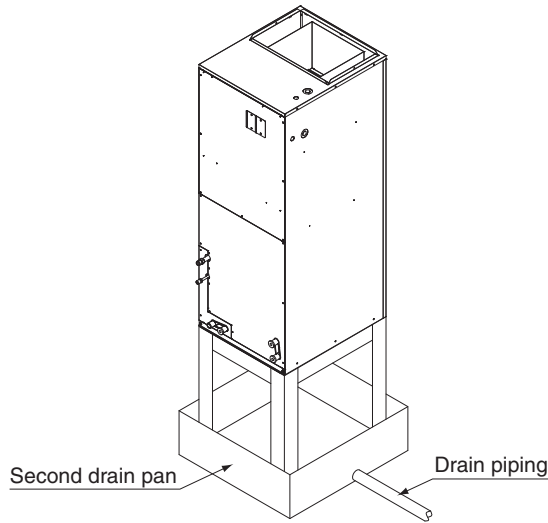

If installed horizontally

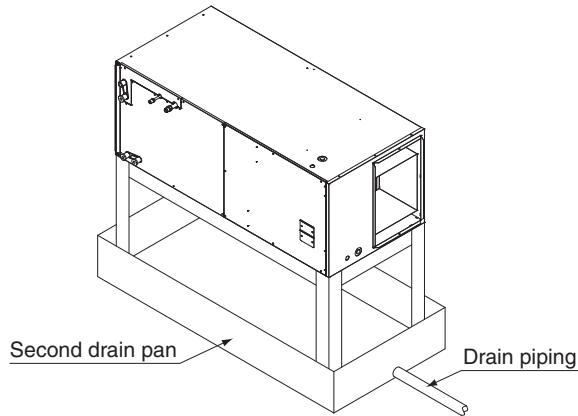

- (4) Check if the unit is horizontally level.

CAUTION

- Make sure the unit is installed level using a level: four sides. (One thing to watch out for in particular is if the unit is installed so that the slope is not in the direction of the drain piping, this might cause leaking.)

If installed vertically

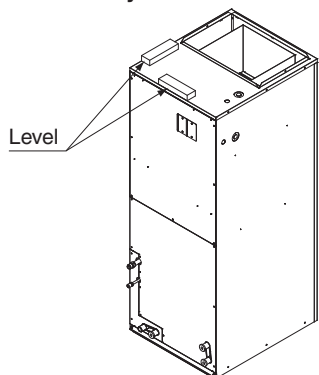

If installed horizontally

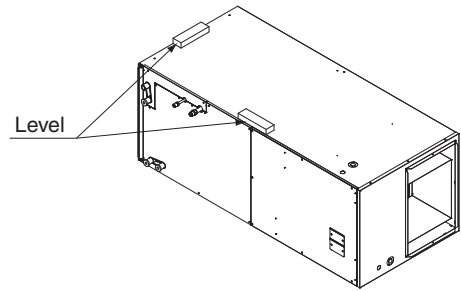

- (5) Secure the unit firmly to prevent it from falling.

5. REFRIGERANT PIPING WORK

⟨Observe the requirements listed below for refrigerant piping sizes.⟩

Liquid	Gas
3/8 in.	5/8 in.

⟨Execute heat insulation work completely on both sides of the gas piping and the liquid piping or else a water leakage might result.

Failing to insulate the pipes may cause leaking or burns. And be sure to use the insulation which can withstand such temperatures of 248°F or more for the gas piping. Reinforce the insulation on the refrigerant piping according to the installation environment. If the temperature or humidity in the product installation location might reach 86°F or 80%, respectively. Condensation may form on the surface of the insulation.⟩

CAUTION

Follow the points at below.

- Use a tube cutter and flare suitable for the type of refrigerant.
- To prevent dust, moisture or other foreign matter from infiltrating the piping, either pinch the end or cover it with tape.
- Do not allow anything other than the designated refrigerant to get mixed into the refrigerant circuit, such as air. If any refrigerant gas leaks while working on the unit, immediately ventilate the room.

- (1) Connect the piping.

- The outdoor unit is filled with refrigerant.
- When connecting or disconnecting piping to or from the unit, **be sure to use two spanners and two torque wrenches. (Refer to Fig. 3)**

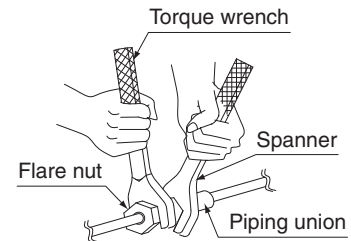

Fig. 3

- Refer to Table 2 for the processing dimensions of the flare.
- Use the flare nut provided with the unit.
- **Apply ether oil or ester oil only to inner side of the flare** and screw in the flare nut three to four turns first by hand at the time of connecting the flare nut. (Refer to Fig. 4)

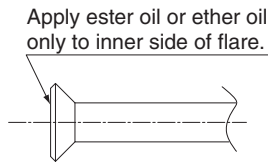

Fig. 4

- Refer to Table 2 for the corresponding tightening torque.

Table 2

Pipe size	Tightening torque	Flare dimensions A (in.)	Flare shape
φ 3/8	26.7 ±2.6 lbf-ft	0.504 – 0.520	
φ 5/8	50.6 ±5.0 lbf-ft	0.760 – 0.776	

CAUTION

- **Do not excessively tighten the flare nut.** Doing so will break the flare nut and refrigerant leakage may result.
- **Make sure that all parts around the flare are free of oil.** The drain pan and the resin part may be deteriorated if oil is attached.

- If no torque wrenches are available, refer to Table 3 as a standard. When the flare nut is tightened with the spanner, the tightening torque should increase suddenly. Tighten the flare nut further for the corresponding angle shown in Table 3.

Table 3

Pipe size	Further tightening angle	Recommended arm length of tool
φ 3/8	60 to 90 degrees	Approx. 7-7/8 in.
φ 5/8	30 to 60 degrees	Approx. 11-13/16 in.

- (2) On completion of installation work, **check that there is no gas leakage.**

- (3) Refer to the illustration on the right-hand side and be sure to perform heat insulation work on the piping joints after gas leakage checks. (Refer to Fig. 5)

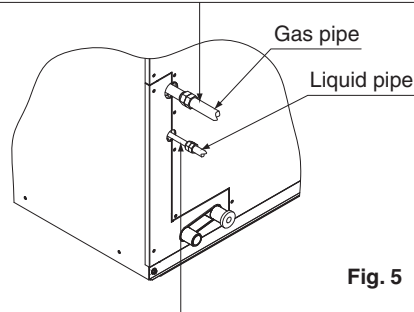
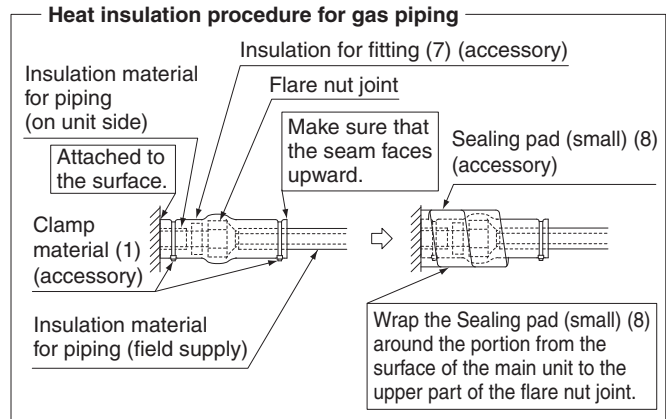
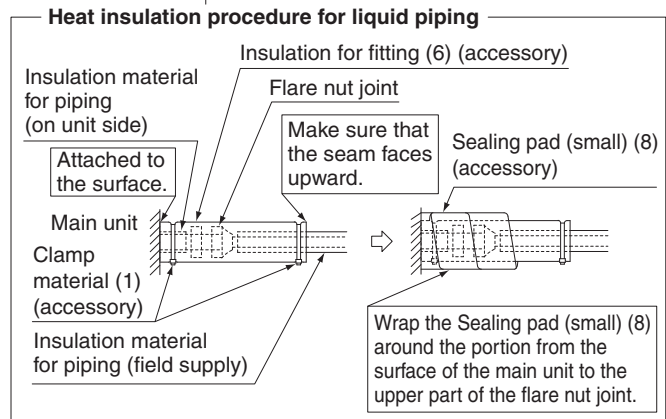

Fig. 5



- Use the Insulation for fitting (6) and (7) provided to the liquid piping and gas piping, respectively, and conduct heat insulation work. (Tighten both edges of the Insulation for fitting (6) and (7) for each joint with the Clamp material (1).)
- Make sure that the joint of the Insulation for fitting (6) and (7) for the joint on the liquid piping and gas piping side faces upward.
- Wrap the Sealing pad (small) (8) around the Insulation for fitting (6) and (7) for the joint (flare nut part).

CAUTION

- Be sure to insulate any field piping all the way to the piping connection inside the unit. Any exposed piping may cause condensation or burns if touched.

- When brazing the refrigerant piping, perform nitrogen replacement first, or perform the brazing while feeding nitrogen into the refrigerant piping. (Refer to Fig. 6)

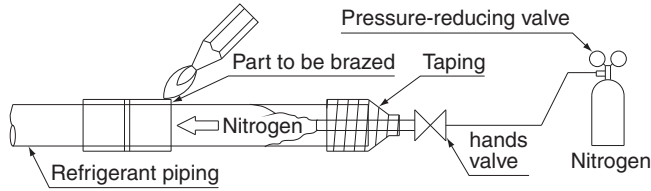

Fig. 6

CAUTION

- When brazing piping while feeding nitrogen inside the piping, make sure to set the nitrogen pressure to 2.9 psi or less using the pressure reducing valve. (This pressure is such that a breeze is blown to your cheek.)

DANGER

- Use of oxygen could result in an explosion resulting in serious injury or death. Only use dry nitrogen gas.
- Refrigerant gas may produce toxic gas if it comes in contact with fire such as from a fan heater, stove or cooking device. Exposure to this gas could cause severe injury or death.

NOTE

- Do not use flux when brazing refrigerant piping. Therefore, use the phosphor copper brazing filler metal (BCuP) which does not require flux. Flux has an extremely negative effect on refrigerant piping systems. For instance, if chlorine based flux is used, it will cause piping corrosion. Flux containing fluorine will damage refrigerant oil.

6. DRAIN PIPING WORK

CAUTION

- Make sure all water is out before making the duct connection.

(1) Install drain piping as described Fig. 7.

In case of vertical installation

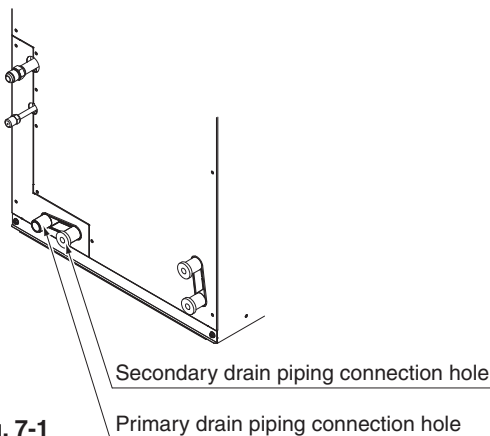

Fig. 7-1

In case of horizontal installation

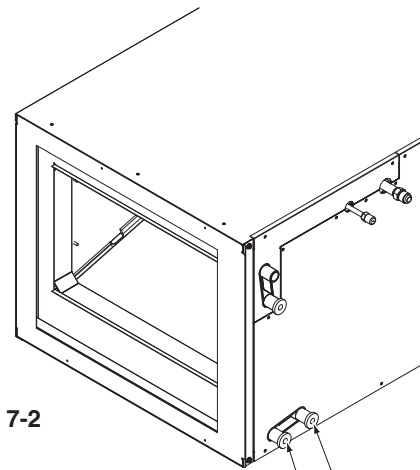

Fig. 7-2

Primary drain piping connection hole
Secondary drain piping connection hole

- Perform drain work so that the unit is drained thoroughly. (Be sure to insulate the following 2 locations since condensation may cause water leakage.)
- Be sure to use the included Drain hose (5) and Metal clamp (4).
Insert the Drain hose (5) up to the step on the drain socket. Within the range of the tape section at the end of the inserted hose, tighten the Metal clamp (4) to the torques of 0.99 ± 0.1 lbf-ft (11.9 ± 1.2 lbf-in).

CAUTION

- Do not tighten the Metal clamp (4) to torques exceeding the specification. Otherwise, the Drain hose (5), the socket, and the Metal clamp (4) may become damaged.
- To avoid the Sealing pad (large) (9) from tearing at the edge of the Metal clamp (4), either affix a plastic tape on the edge of the Metal clamp (4) or bend the end of the Metal clamp (4) inward as shown in the figure.

<When affixing plastic tape>

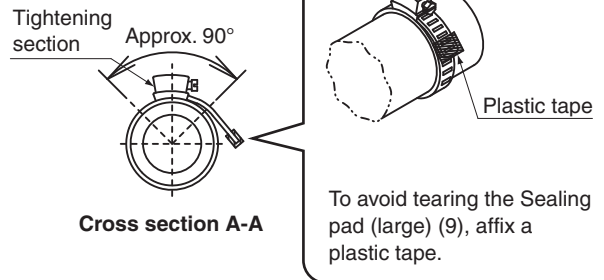

Cross section A-A

<When bending the end>

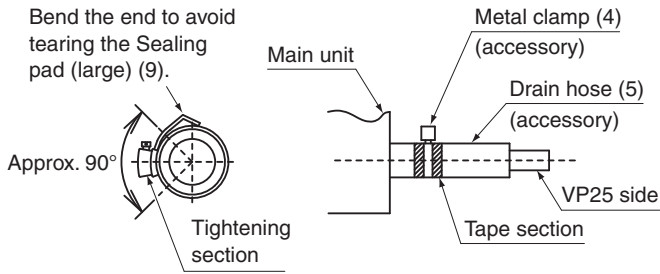

- Refer to the following figure and check the drain. Then, use the included Sealing pad (large) (9) to thermally insulate the Metal clamp (4) and the Drain hose (5).

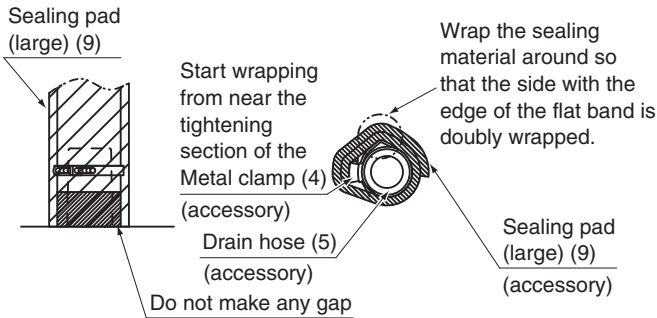

<Drain socket thermal insulation work>

- The drain pan has connections for a primary and secondary drain.
- The diameter of the drain piping should be greater than or equal to the diameter of the connecting pipe (vinyl tube; pipe size : 25/32 in. ; outer dimension : 1-1/32 in.) (not including a riser)
- Keep piping runs short with a downward slope of at least 1/100 to prevent air pocket from forming.
- Be sure to install a drain trap at the drain outlet since the inside of the unit is at negative pressure relative to atmospheric pressure during operation.
- To keep the piping from becoming clogged with dirt, avoid bends where possible and install so that traps can be cleaned.

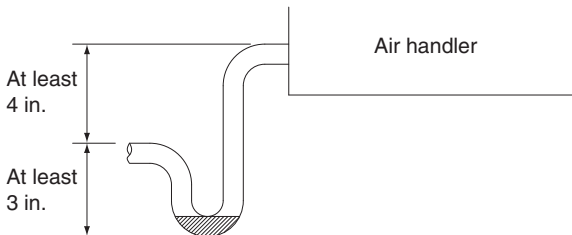

- Observe the following guidelines when installing concentrated drain piping. Select the thickness of the concentrated drain piping to reflect the capacity of the machine to which it will be connected.

CAUTION

- Water accumulating in the drain piping can cause the drain to clog.

<PRECAUTIONS>

Drain piping connections

- Do not connect the drain piping directly to sewage piping that smell of ammonia. The ammonia in the sewage might enter the indoor unit through the drain piping and corrode the heat exchanger.
- Do not twist or bend the drain hose, as excessive force may cause it to leak.

(2) After piping work is finished, check drainage flows smoothly.

- Gradually insert approximately 1 quart of water into the drain pan to check drainage in the manner described below.

7. INSTALLING THE DUCT

Exercise care regarding the following when performing duct work.

- Verify that duct work does not exceed the unit's setting range of external static pressure (up to 0.5 Wg at "HH" speed).
- Install canvas ducts at air outlets and inlets so that vibrations from the main unit are not transmitted to ducts or the floor. Additionally, line the duct with sound-absorbing material (heat insulation material) as necessary.
- Be sure to install an air filter to the product's air inlet or to a field-supplied air inlet inside the air passage on the suction side.
- Perform the curing and other work during duct welding so that the inside of the product is not exposed to spatter.
- If the metal duct passes through a metal lath, wire lath, or metal plate of a wooden structure, isolate the duct from the wall electrically.
- Be sure to heat-insulate the duct to prevent the formation of condensation. (Material: Glass wool or polyethylene foam; thickness: 1 inch.)
- Explain to the customer how to operate and clean field-supplied components such as air filters, air inlet grilles, air outlet grilles.
- To prevent drafts, locate the air outlet grille on the indoor side so that warm air from the outlet does not come into direct contact with room occupants.
- When an electric heater (optional) is installed, use metal duct and wrap the duct with a glass-wool insulation material.

8. ELECTRIC WIRING WORK

8-1 GENERAL INSTRUCTIONS

- Shut off the power before doing any work.
- All field supplied parts and materials, electric works must conform to local codes.
- Use copper conductors only.
- See also the "Wiring Diagram Label" located inside the unit's front cover.
- For details on hooking up the remote controller, refer to the "REMOTE CONTROLLER INSTALLATION MANUAL".
- All wiring must be performed by an authorized electrician.
- Install a wiring interrupter or ground-fault circuit interrupter for the power wiring.
- Make sure the ground resistance is no greater than 100Ω.
- To avoid short circuiting the power supply wire, be sure to use insulated terminals.
- Do not turn on the power supply (wiring interrupter or ground-fault circuit interrupter) until all other work is done.

⚠ DANGER

- Do not ground units to water piping, telephone wires or lightning rods because incomplete grounding could cause a severe shock hazard resulting in severe injury or death, nor to gas piping because a gas leak could result in an explosion which could lead to severe injury or death.

8-2 LIST OF STANDARD WIRING EQUIPMENT

Power supply wiring (including ground wire)		Transmission wiring Remote controller wiring	
Protective device	Size	Wire	Size
15A	Must comply with local codes.	2-conductor, stranded, non-shielded copper/PVC or vinyl jacket	AWG18 – 16

NOTES

- If the wiring is in a place where people it can be easily touched by people, install a ground-fault circuit interrupter to prevent electric shock.
 - When using a ground-fault circuit interrupter, make sure to select one useful also to protection against overcurrent and short-circuit.
When using a ground-fault circuit interrupter only for grounding device, make sure to use a wiring interrupter together.
- The length of the transmission wiring and remote controller wiring are as follows.

Length of the transmission wiring and remote controller wiring

Outdoor unit – Indoor unit	Max. 3280 ft. (Total wiring length: 6560 ft.)
Indoor unit – Remote controller	Max. 1640 ft.

8-3 ELECTRICAL CHARACTERISTICS

Units				Power supply		Fan motor	
Model	Hz	Volts	Voltage range	MCA	MOP	HP	FLA
18 type	60	208/ 230	Min. 187 Max. 229/ Min. 207 Max. 253	1.5	15	350	1.2
24 type				1.6			1.3
30 type				2.3			1.8
36 type				2.8			2.2
42 type				3.6		400	2.8

- MCA: Minimum Circuit Amps (A)
MOP: Max Overcurrent Protective Device (A)
HP: Fan motor output (W)
FLA: Full Load Amps (A)

9. WIRING EXAMPLE

9-1 HOW TO CONNECT WIRINGS

(Precautions when laying power supply wiring)

- Wiring of different thicknesses cannot be connected to the power supply wiring terminal block. Slack in the power supply wiring may cause abnormal heat.
- Use sleeve-insulated round crimp-style terminals for connections to the power supply wiring terminal block. When none are available, connect wires of the same diameter to both sides, as shown in the figure.

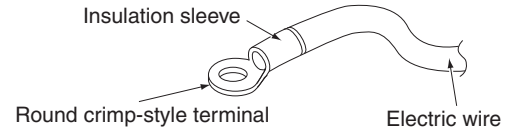

Connect wires of the same gauge to both sides.

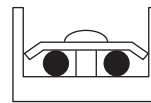

Do not connect wires of the same gauge to one side.

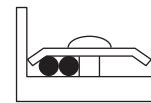

Do not connect wires of different gauges.

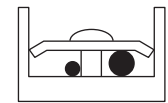

If the wiring gets too hot due to loose power-supply wiring, use the following precautions:

- For wiring, use the designated power supply wiring and connect firmly, then secure to prevent outside pressure being exerted on the terminal board.
- Use the correct screwdriver for tightening the terminal screws. If the blade of screwdriver is too small, the head of the screw might be damaged, and the screw will not be properly tightened.
- If the terminal screws are tightened too hard, screws might be damaged.
- Refer to Table 4 for the tightening torque of the terminal screws.

Table 4

Terminal block	Tightening torque (ft · lbf)
Remote controller / transmission wiring terminal block (6P) (10P)	0.58 – 0.72
Power supply wiring terminal block (3P)	0.87 – 1.06

(1) Remove the front panel (upper).

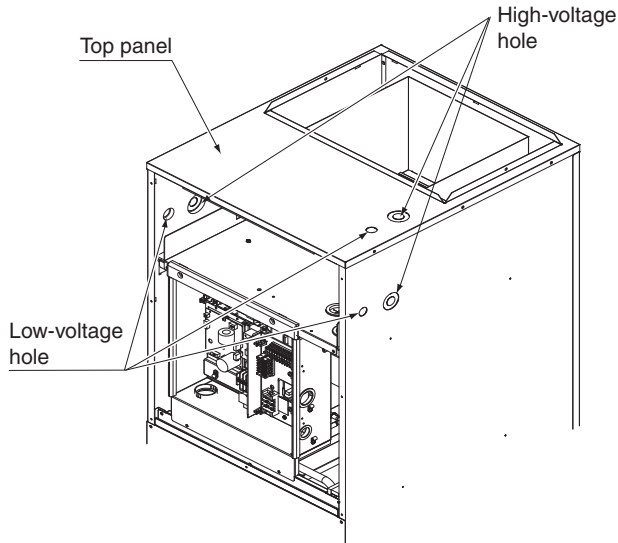

(2) Remove the electric component box cover.

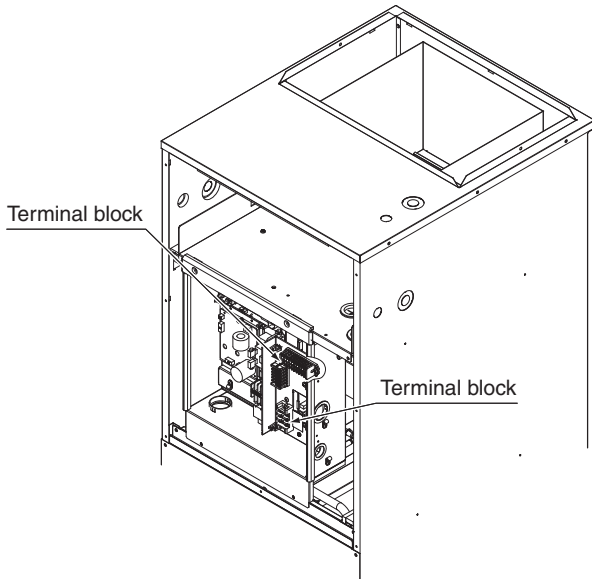

(3) Pass the power supply wiring and the ground wire through the top panel's high-voltage hole (requires use of conduit) and pass the remote controller wiring and transmission wiring through the top panel's low-voltage hole.

- Pass the included insulation tube through the hole in the panel before connecting the electric wires and the ground wire to the terminal block shown in Fig. 8.
- Pass the included insulation tube through the hole in the panel before connecting the remote controller wiring and transmission wires to the terminal block shown in Fig. 8.
- Then secure them in place with the included Clamp material (1) as shown in Fig. 8 to protect them from external force from outside the unit.
- If the power supply voltage is 208V, change the transformer wire connection from the 240V terminal to the 208V terminal. (Refer to Fig. 9)

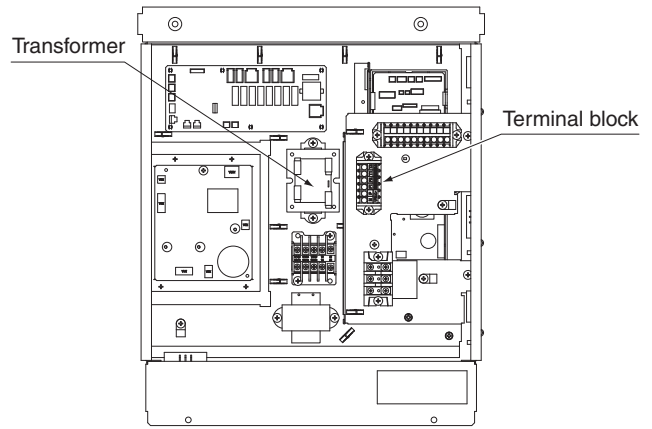

<FTQ18,24,30,36PBVJU models>

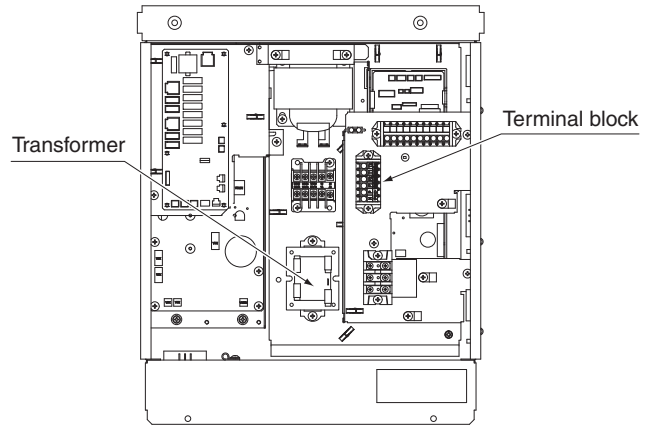

<FTQ42PBVJU model>

Fig. 8

Changing the transformer wire connection

Connector

(Connect the wire to the 208V terminal. Be sure to insert the wire securely until a clicking sound is produced.)

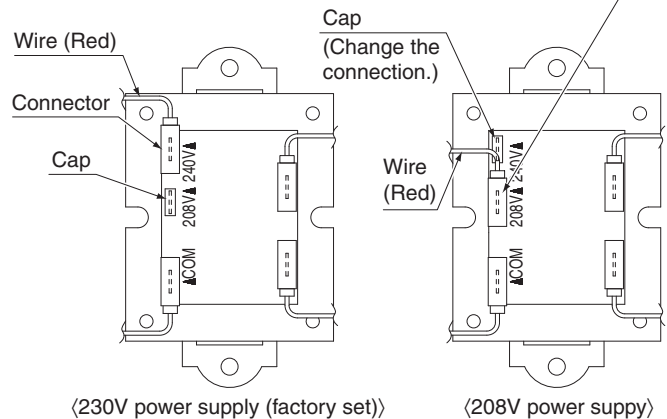

<230V power supply (factory set)>

<208V power supply>

Fig. 9

How to use insulation tube.

- Use the insulation tube to cover the wiring.
- Joint the insulation tube with the tape and cut off the tube sticking out of the unit.

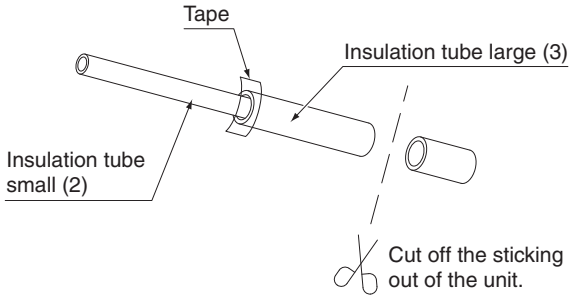

- (4) **Pass the power supply wiring and the ground wire through the conduit (conduit should be field supplied). The hole for running wires through should be sealed completely to prevent air from entering.**

* When installing an optional electric heater kit, run both the power supply wiring and ground wire of the electric heater kit through the conduit.

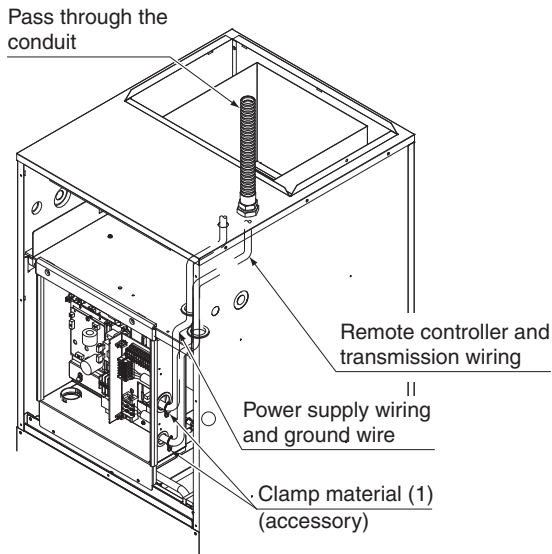

- (5) **Install the front panel (upper).**

⚠ DANGER

- Use only specified wire and connect wires to terminals tightly. Be careful that wires do not place external stress on terminals. Keep wires in neat order so as to not obstruct other equipment. Make sure that the electric component box cover closes tightly. Incomplete connections could result in overheating, and in worse cases, electric shock or fire.

⚠ WARNING

- Never connect power supply wiring to the terminal block for remote controller wiring as this could damage the entire system.

⚠ CAUTION

- When doing the wiring, make sure the wiring is neat and does not cause the electric front panel to stick up, then close the panel firmly. When attaching the front panel, make sure you do not pinch any wires.

- Outside the air conditioners, separate the low voltage wiring (remote controller and transmission wiring) and high voltage wiring (ground wire and power supply wiring) by at least 5 in. so that they do not pass through the same place together. Proximity may cause electrical interference, malfunctions, and breakage.

[PRECAUTIONS]

- Refer to the "REMOTE CONTROLLER INSTALLATION MANUAL" on how to install and lay the wiring for the remote controller.
- See also the "Wiring Diagram Label" located inside the unit's blower deck.
- Connect the remote controller and transmission wiring their respective terminal blocks.

⚠ CAUTION

- Do not, under any circumstances, connect the power supply wiring to the remote controller or transmission wiring terminal block. Doing so can destroy the entire system.

[WIRING EXAMPLE]

- Fit the power supply wire of each unit with a switch and fuse as shown in the drawing.

COMPLETE SYSTEM EXAMPLE

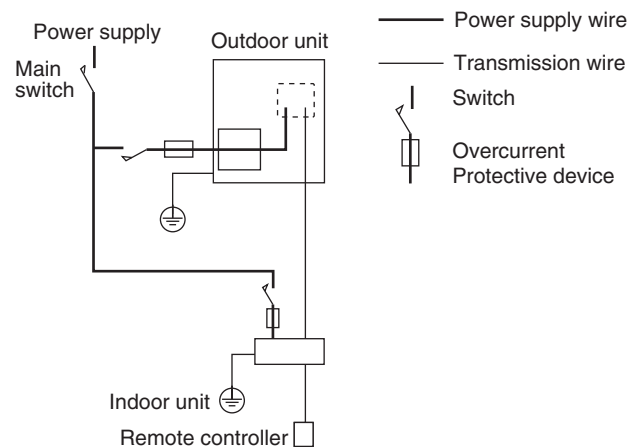

1. When using 1 remote controller for 1 indoor unit. (Normal operation)

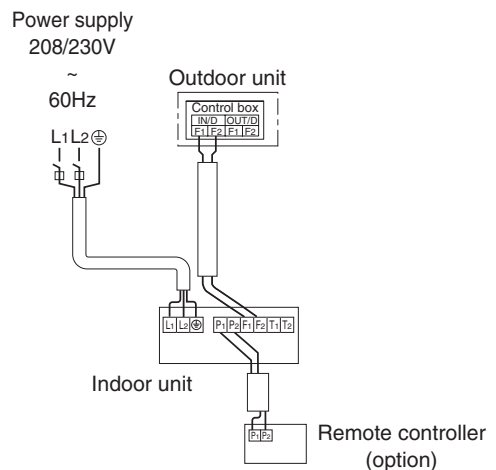

2. When using 2 remote controllers for 1 indoor unit.

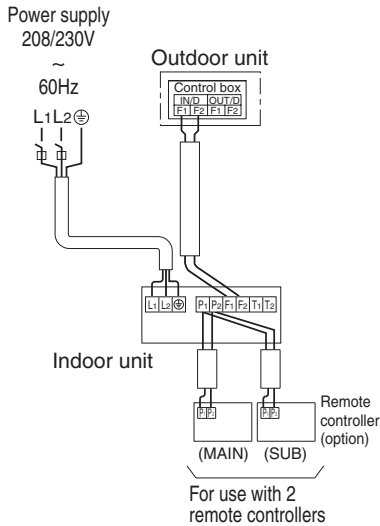

NOTE

1. A single switch can be used to supply power to units on the same system. However, branch switches and branch circuit breakers must be selected carefully.
2. Do not ground the equipment on gas piping, water piping or lightning rods, or crossground with telephones. Improper grounding could result in electric shock.

9-2 CONTROL BY 2 REMOTE CONTROLLERS (Controlling 1 indoor unit by 2 remote controllers)

- When using 2 remote controllers, one must be set to "MAIN" and the other to "SUB".
- If the remote controller to be used is Model BRC1E71, read the installation manual supplied with the remote controller.

MAIN/SUB CHANGEOVER

- (1) Press and hold the operation switch button of the remote controller for one of the two units for four seconds or more. When the LCD display changes from the display as the main remote controller to the display as the sub remote controller, the setting is complete.
- (2) Remove the front panel.
- (3) Add remote controller 2 (SUB) to the terminal block for remote controller (P₁, P₂) in the electric component box. (There is no polarity.)

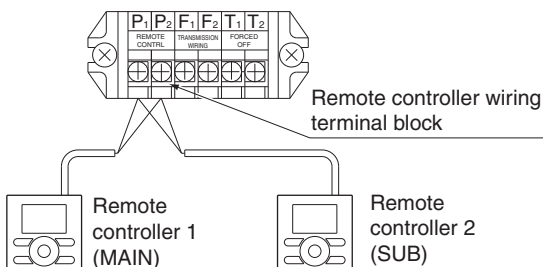

9-3 REMOTE CONTROL (FORCED OFF AND ON/OFF OPERATION)

- Connect input lines from the outside to the terminals T₁ and T₂ on the terminal block (6P) for remote controller to achieve remote control.
- See the "10. FIELD SETTING AND TEST RUN" for details on operation.

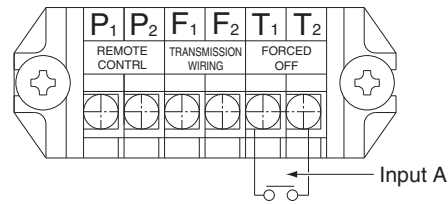

Wire specification	Sheathed vinyl cord or cable (2 wires)
Gauge	AWG18 – 16
Length	Max. 328 ft.
External terminal	Contact that can ensure the minimum applicable load of 15 V DC, 1 mA.

10. FIELD SETTING AND TEST RUN

〈Field settings may have to be performed using the remote controller, depending on the type of installation.〉

- (1) Make sure the control box covers are closed on the indoor and outdoor units.
- (2) Depending on the type of installation, make the field settings from the remote controller after the power is turned on, following the "Field Settings" manual which came with the remote controller.
 - The settings can select "Mode No.," "FIRST CODE NO." and "SECOND CODE NO."
 - The "Field Settings" included with the remote controller lists the order of the settings and method of operation.

FIELD SET MODE

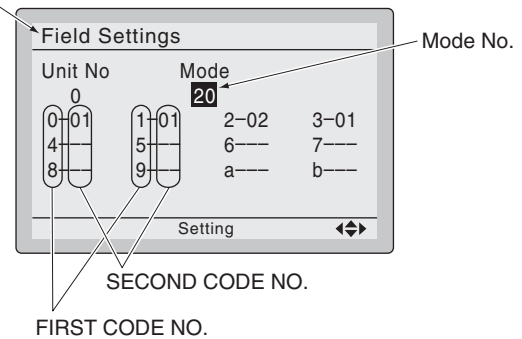

- Lastly, make sure the customer keeps the "Field Settings" manual, along with the operating manual, in a safe place.

10-1 SETTINGS WHEN USING THE OPTIONAL REMOTE SENSOR

This product does not include an air inlet thermistor. It uses a remote controller thermistor for control purposes. For this reason, it is necessary to install an optional remote thermistor in the following cases:

- When the remote controller will be installed at a location where it cannot accurately measure the indoor temperature.
- When using a remote controller without a built-in thermistor (simple remote controller, wireless remote controller, no remote controller).

When using an optional remote sensor, change the settings as described Table 5:

(The SECOND CODE NO. is set to "03" when shipped.)

Table 5

	Mode No.	FIRST CODE NO.	SECOND CODE NO.
To use both the remote controller thermistor and the remote sensor	10 (20)	2	01
To use only the remote sensor			02
To use only the remote controller thermistor			03*

* factory set

10-2 REMOTE CONTROL SETTING

- Forced off and ON/OFF operation should be selected by selecting the SECOND CODE NO. as shown in the table Table 6.

Table 6

External ON/OFF input	Mode No.	FIRST CODE NO.	SECOND CODE NO.
Forced off	12 (22)	1	01*
ON/OFF operation			02

* factory set

- Input A of forced off and ON/OFF operation work as shown in Table 7.

Table 7

Forced off	ON/OFF operation
Input A "on" to force a stop (remote controller reception prohibited)	Unit operated by changing input A from "off" to "on"
Input A "off" to allow remote controller	Unit stopped by changing input A from "on" to "off"

10-3 SETTING THE FILTER SIGN DISPLAY INTERVAL

- Explain the following to the customer if the filter dirt settings have been changed.
- The filter sign display time is set to 2500 hours (equivalent to 1 year's use) when shipped.
- The settings can be changed to not display.
- When installing the unit in a dusty place, set the filter sign display time to shorter intervals (1,250 hours).
- Explain it to the customer that the filter needs to be cleaned regularly to prevent clogging and also the time that is set.

Mode No.	FIRST CODE NO.		SECOND CODE NO.	
			01	02
10 (20)	0	Filter dirt	low	high
	1 (low/high)	Displayed time (units: hours)	2500/1250	10000/5000
	3	Filter sign display	ON	OFF

10-4 EXTERNAL STATIC PRESSURE SETTING

(1) Setting remote controller.

The "SECOND CODE NO." is set to 11 (an external static pressure of 0.4 in.W.G.) at factory set.

External Static Pressure (in.W.G.)	Mode No.	FIRST CODE NO.	SECOND CODE NO.
0.150	13 (23)	06	01
0.175			02
0.200			03
0.225			04
0.250			05
0.275			06
0.300			07
0.325			08
0.350			09
0.375			10
0.400			11
0.425			12
0.450			13
0.475			14
0.500			15

⚠ CAUTION

- Keep in mind that a shortage of airflow quantity or water leakage will result because the air conditioner will be operated outside the rated range of airflow quantity if the external static pressure is wrongly set.

10-5 INSTALLATION OF AN AIR FILTER

(1) Take off the part on the bottom of the front panel.

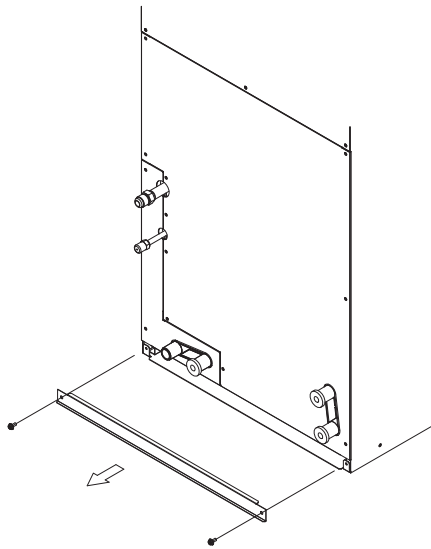

(2) Insert the air filter as far as it can go.

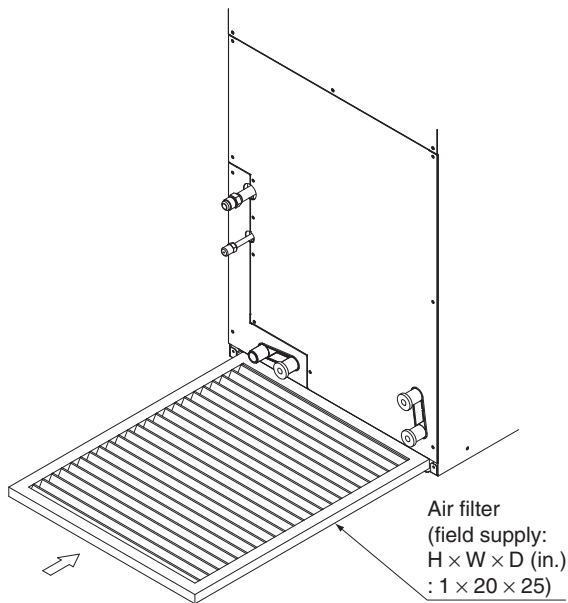

10-6 SETTING FOR LOCAL SUPPLIED OPTION

(1) Installation of the humidifier, economizer and air purifier (UV lamp)

- Humidifier, economizer and air purifier (UV lamp) are sold separately. For the method of installation, refer to the manual provided with each optional product.

⚠ WARNING

- If the unit is installed with an electric heater, install the optional product at a location where it is not exposed directly to the heat from the electric heater. Direct exposure to heat can result in an equipment malfunction or fire.

(2) Connect the wires

- Run the wires through the low-voltage hole.
- Connect the wires to the terminal block (10P) of the product. The terminal Nos. for wire connection are shown below. Refer to the information as needed. Terminal Nos. are indicated on the name plate for the terminal block.

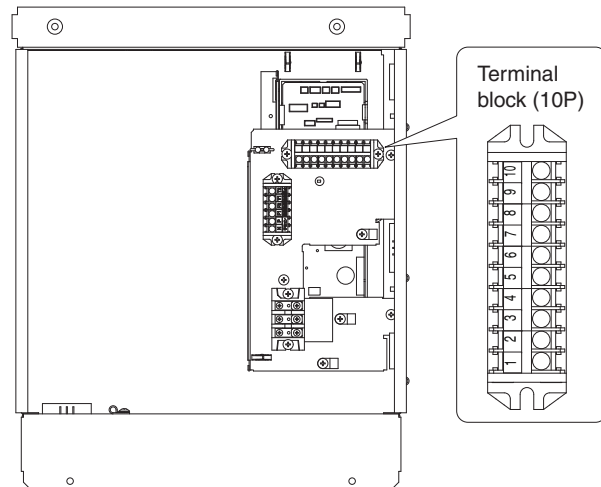

Terminal No.	Input/output signal
1, 2	Outputs: indoor unit ON signal. (AC 24V)
3, 4	Outputs: indoor unit cooling THERMO ON signal. (AC 24V)
5, 6	Receives input: Air purifier operation ON signal. (dry contact)
7, 8	Receives input: Humidifier operation ON signal. (dry contact)
9, 10	Receives input: Forced closure of Indoor Unit Electronic Expansion Valve during cooling operation. (dry contact)

(3) On-site setting of air purifier/humidifier

Mode No.	FIRST CODE NO.		01	02	03
14 (24)	4	FAN SPEED UNDER OPERATING purifier and humidifier	Refer to remote controller setting SPEED	H*	
14 (24)	5	FAN RESIDUE TIME FOR HUMIDIFIER	30 [sec.]	60* [sec.]	120 [sec.]

* factory set

10-7 SETTINGS FOR SEPARATELY SOLD ACCESSORIES

- See the instruction manuals included with optional accessories for the necessary settings.

〈When using a wireless remote controller〉

- A wireless remote controller address needs to be set when using a wireless remote controller. See the installation manual included with the wireless remote controller for details on how to make the settings.

Perform a test run according to the outdoor unit's installation manual.

- The operation lamp of the remote controller will flash when a malfunction occurs. Check the malfunction code on the liquid crystal display to identify the point of trouble. An explanation of malfunction codes and the corresponding trouble is provided in "CAUTION FOR SERVICING" of the outdoor unit.

If the display shows any of the following, there is a possibility that the wiring was done incorrectly or that the power is not on, so check again.

Remote controller display	Contents
"A8" lit	<ul style="list-style-type: none"> • Error in power supply voltage to indoor unit.
"C1" lit	<ul style="list-style-type: none"> • Fan driver PCB of indoor unit ↔ indoor control PCB transmission error.
"C6" lit	<ul style="list-style-type: none"> • Improper combination of fan driver PCB of indoor unit or setting failure in control PCB type.
"U3" lit	<ul style="list-style-type: none"> • Test operation of outdoor unit has not been finished.
"CENTRAL CONTROL" is lit up	<ul style="list-style-type: none"> • There is a short circuit at the FORCED OFF terminals (T₁, T₂)
"U4" is lit up "UH" is lit up	<ul style="list-style-type: none"> • The power on the outdoor unit is off. • The outdoor unit has not been wired for power supply. • Incorrect wiring for the transmission wiring and / or FORCED OFF wiring.
No display	<ul style="list-style-type: none"> • The power on the indoor unit is off. • The indoor unit has not been wired for power supply. • Incorrect wiring for the remote controller wiring, the transmission wiring and / or the FORCED OFF wiring.



CAUTION

- Always stop the test run using the remote controller to stop operation.

DAIKIN AC (AMERICAS), INC.

1645 Wallace Drive, Suite 110
Carrollton, TX 75006 USA

info@daikinac.com
www.daikinac.com

DAIKIN INDUSTRIES, LTD.

Head office:

Umeda Center Bldg., 2-4-12, Nakazaki-Nishi,
Kita-ku, Osaka, 530-8323 Japan

Tokyo office:

JR Shinagawa East Bldg., 2-18-1, Konan,
Minato-ku, Tokyo, 108-0075 Japan

