



# DCG COMMERCIAL

Cooling Capacity:  
 15 Tons :180,000 BTU/H  
 20 Tons: 240,000 BTU/h

Heating Capacity:  
 15 Tons: 350,000 BTU/H  
 20 Tons: 400,000 BTU/h

## 15- & 20-TON, THREE-PHASE PACKAGED GAS/ELECTRIC

### ■ Contents

Nomenclature.....	2
Product Specifications.....	4
Expanded Cooling Data .....	6
Airflow Data.....	10
Dimensions .....	12
Wiring Diagrams .....	17
Accessories .....	25



### ■ Standard Features

- R-410A chlorine-free refrigerant
- Patented tubular heat exchanger
- High-efficiency scroll compressor
- Copper tube / aluminum fin coils
- High- and low-pressure switches
- High-capacity, steel-cased filter drier
- Built-in filter rack with standard 2" filters (convertible to 4" filters)
- 24-volt terminal strip
- Contactor with lugs
- Easy to service
- Bottom utility entry
- Complies with California Low NOx emissions standards
- AHRI Certified; ETL Listed
- Units meet the performance outlined in Table 6.8.1A of ASHRAE Standard 90.1-2010

### ■ Cabinet Features

- Heavy-gauge, galvanized-steel cabinet with UV-resistant powder-paint finish
- Condenser hail guards
- Full perimeter rail
- Sloped drain pan



\* Complete warranty details available from your local dealer or at [www.daikincomfort.com](http://www.daikincomfort.com).



# NOMENCLATURE

	D	C	G	240	400	3	B	*	*	*	A	*																							
	1	2	3	4,5,6	7,8,9	#	#	#	#	#	#	#																							
<b>Revision Levels</b>																																			
Major & Minor																																			
<b>Factory-Installed Options</b>																																			
<b>Brand</b>	D Daikin																																		
<b>Configuration</b>	C Commercial																																		
<b>Application</b>	C Cooling G Gas Heat H Heat Pump																																		
<b>Nominal Cooling Capacity</b>	<table border="1"> <tr> <td>036</td> <td>3 Tons</td> <td>102</td> <td>8½ Tons</td> </tr> <tr> <td>048</td> <td>4 Tons</td> <td>120</td> <td>10 Tons</td> </tr> <tr> <td>060</td> <td>5 Tons</td> <td>150</td> <td>12½ tons</td> </tr> <tr> <td>072</td> <td>6 Tons</td> <td>180</td> <td>15 Tons</td> </tr> <tr> <td>090</td> <td>7½ Tons</td> <td>240</td> <td>20 Tons</td> </tr> </table>											036	3 Tons	102	8½ Tons	048	4 Tons	120	10 Tons	060	5 Tons	150	12½ tons	072	6 Tons	180	15 Tons	090	7½ Tons	240	20 Tons				
036	3 Tons	102	8½ Tons																																
048	4 Tons	120	10 Tons																																
060	5 Tons	150	12½ tons																																
072	6 Tons	180	15 Tons																																
090	7½ Tons	240	20 Tons																																
<b>Nominal Heating Capacity</b>	<table border="1"> <thead> <tr> <th>Gas/Electric</th> <th>A/C H/P</th> <th>Factory-Installed Electric Heat</th> </tr> </thead> <tbody> <tr> <td>045</td> <td>45,000 BTU/h</td> <td>XXX No Heat</td> </tr> <tr> <td>090</td> <td>90,000 BTU/h</td> <td>010 10 kW 030 30 kW</td> </tr> <tr> <td>115</td> <td>115,000 BTU/h</td> <td>015 15 kW 031 30 kW</td> </tr> <tr> <td>140</td> <td>140,000 BTU/h</td> <td>016 15 kW 045 45 kW</td> </tr> <tr> <td>210</td> <td>210,000 BTU/h</td> <td>018 18 kW 046 45 kW</td> </tr> <tr> <td>350</td> <td>350,000 BTU/h</td> <td>020 20 kW 060 60 kW</td> </tr> <tr> <td>400</td> <td>400,000 BTU/h</td> <td>025 25 kW</td> </tr> </tbody> </table> <p>See product specifications for heat size(s) available for each capacity.</p>											Gas/Electric	A/C H/P	Factory-Installed Electric Heat	045	45,000 BTU/h	XXX No Heat	090	90,000 BTU/h	010 10 kW 030 30 kW	115	115,000 BTU/h	015 15 kW 031 30 kW	140	140,000 BTU/h	016 15 kW 045 45 kW	210	210,000 BTU/h	018 18 kW 046 45 kW	350	350,000 BTU/h	020 20 kW 060 60 kW	400	400,000 BTU/h	025 25 kW
Gas/Electric	A/C H/P	Factory-Installed Electric Heat																																	
045	45,000 BTU/h	XXX No Heat																																	
090	90,000 BTU/h	010 10 kW 030 30 kW																																	
115	115,000 BTU/h	015 15 kW 031 30 kW																																	
140	140,000 BTU/h	016 15 kW 045 45 kW																																	
210	210,000 BTU/h	018 18 kW 046 45 kW																																	
350	350,000 BTU/h	020 20 kW 060 60 kW																																	
400	400,000 BTU/h	025 25 kW																																	
<b>Voltage</b>	<table border="1"> <tr> <td>1</td> <td>208-230/1/60</td> <td>4</td> <td>460/3/60</td> </tr> <tr> <td>3</td> <td>208-230/3/60</td> <td>7</td> <td>575/3/60</td> </tr> </table>											1	208-230/1/60	4	460/3/60	3	208-230/3/60	7	575/3/60																
1	208-230/1/60	4	460/3/60																																
3	208-230/3/60	7	575/3/60																																
<b>Supply Fan/Drive Type/Motor</b>	B Belt Drive V 2-Speed Belt Drive D Direct Drive																																		
<b>Factory-Installed Options</b>	<ul style="list-style-type: none"> <li>X No Options</li> <li>A Downflow Economizer</li> <li>H Disconnect Switch (non-fused)</li> <li>J Downflow Economizer; Disconnect Switch (non-fused)</li> </ul>																																		
Note:	Not all options available for all products.																																		
<b>Factory-Installed Options</b>																																			
X	No Options																																		
A	Non-powered convenience outlet																																		
B	Powered convenience outlet																																		
C	Low-ambient kit																																		
D	Return air smoke detector																																		
E	Supply air smoke detector																																		
F	Non-powered convenience outlet; Low-ambient kit																																		
G	Non-powered convenience outlet; Return air smoke detector																																		
H	Non-powered convenience outlet; Supply air smoke detector																																		
J	Non-powered convenience outlet; Return & Supply air smoke detectors																																		
K	Non-powered convenience outlet; Low-ambient kit; Supply air smoke detector																																		
L	Non-powered convenience outlet; Low-ambient kit																																		
M	Return & Supply air smoke detectors																																		
N	Powered convenience outlet; Low-ambient kit																																		
O	Powered convenience outlet; Return air smoke detector																																		
P	Powered convenience outlet; Return & Supply air smoke detectors																																		
Q	Powered convenience outlet; Supply air smoke detector																																		
R	Powered convenience outlet; Low-ambient kit; Return air smoke detector																																		
T	Powered convenience outlet; Low-ambient kit; Return & Supply air smoke detectors																																		
U	Non-powered convenience outlet; Low-ambient kit; Return air smoke detector																																		
V	Low-ambient kit; Return air smoke detector																																		
W	Low-ambient kit; Supply air smoke detector																																		
Y	Low-ambient kit; Return & Supply air smoke detectors																																		
Z	Return & Supply air smoke detectors																																		
X	Standard Aluminized Heat Exchanger																																		
S	Stainless-Steel Heat Exchanger																																		

## NOMENCLATURE (CONT.)

### FACTORY-INSTALLED OPTIONS

- Stainless-Steel Heat Exchanger (DCG units only): A tubular heat exchanger made of 409-type stainless steel is installed in the unit.
- Low-Ambient Kit: Allows for cooling operation at lower outdoor temperatures. On the 3- to 6-ton units, cooling operation is extended from 60°F ambient temperature to 35°F outside air temperature. On 7½- to 20-ton units, cooling operation is extended from 35°F ambient temperature to 0°F outside air temperature.
- Economizers (Downflow): Based on air conditions, can provide outside air to cool the space.
- Electric Heat Kits (DCC and DCH units only): Available in all voltage options.
- Non-powered Convenience Outlet: A 120V, 15A, GFCI outlet makes it easier for technicians to service the unit once an electrician runs power to the outlet.
- Powered Convenience Outlet: A 120V, 15A, GFCI outlet powered with a transformer built into the unit. When a factory-installed powered convenience outlet is installed in the equipment, the unit MCA (Min. Circuit Ampacity) will increase by 7.5A for 208/230V units, increase by 3.75A for 460V units, and by 3A for 575V units. The MOP (Max. Overcurrent Protection) device must be sized accordingly.
- Disconnect Switch (non-fused): A disconnect switch is installed in the unit and factory wiring will be complete from the switch to the unit. Please note that for air conditioning (DCC units) and heat pump models (DCH units), the appropriate electric heat kit must be ordered to be factory-installed along with the disconnect switch (non-fused) when it is ordered. Please note that for models with a powered convenience outlet option and a disconnect switch (non-fused) option, the power to the powered convenience outlet will be shut off when the disconnect switch (non-fused) is in the off position.
- Return Air and/or Supply Air Smoke Detectors: Return air and/or supply air smoke detectors are installed in the unit.
- Two-speed indoor fan blower models are available on 7½, 10, 12½, 15, & 20-ton units. Section 6.4.3.10.b of ASHRAE Standard 90.1-2010 and Section 6.5.3.2.1.a of ASHRAE Standard 90.1-2013 require a minimum of two fan speeds. Section 140.4(m)1 of California Energy Commission Title 24 2013 contains a similar provision. When the units with the two-speed indoor fan blowers operate on a call for the first stage of cooling, the fan operates at low speed, which is 66% of full speed. When the units operate on a call for the second stage of cooling, the fan operates at full speed. In heating operation, the fan operates at full speed. During ventilation operation, the fan operates at low speed.

PRODUCT SPECIFICATIONS — 15 TONS

	DCG180 3503B***A*	DCG180 3503V***A*	DCG180 3504B***A*	DCG180 3504V***A*	DCG180 3507B***A*	DCG180 3507V***A*
<b>COOLING CAPACITY</b>						
Total, BTU/h	180,000	180,000	180,000	180,000	180,000	180,000
Sensible BTU/h	127,500	127,500	127,500	127,500	127,500	127,500
EER / IEER	10.8 / 11.0	10.8 / 12.6	10.8 / 11.0	10.8 / 12.6	10.8 / 11.0	10.8 / 12.6
Decibels	88	88	88	88	88	88
AHRI Reference #s	6502022	6502019	6502022	6502019	6502022	6502019
<b>HEATING CAPACITY</b>						
High Input / Output (KBTU/h)	350 / 280	350 / 280	350 / 280	350 / 280	350 / 280	350 / 280
Low Input / Output (KBTU/h)	262.5 / 210	262.5 / 210	262.5 / 210	262.5 / 210	262.5 / 210	262.5 / 210
Steady State Efficiency (%)	80	80	80	80	80	80
Temperature Rise Range (°F) High/Low	30-60 / 20-50	30-60 / 20-50	30-60 / 20-50	30-60 / 20-50	30-60 / 20-50	30-60 / 20-50
No. of Burners	7	7	7	7	7	7
<b>EVAPORATOR MOTOR / COIL</b>						
Motor Type (Belt Drive)	Std Static	2-Speed Belt	Std Static	2-Speed Belt	Std Static	2-Speed Belt
Indoor Nominal CFM	5,600	5,600	5,600	5,600	5,600	5,600
Indoor Motor FLA (Cooling)	12.7	14	6.4	6.6	5.1	5.2
Horsepower - RPM (Speed: Full / Low)	5.0 - 1,725	5.0 - 1,775/1,185	5.0 - 1,725	5.0 - 1,775/1,185	5.0 - 1,725	5.0 - 1,750/1,185
Metering Device	TXV	TXV	TXV	TXV	TXV	TXV
Filter Size (#)	20 x 25 x 2 (6)	20 x 25 x 2 (6)	20 x 25 x 2 (6)	20 x 25 x 2 (6)	20 x 25 x 2 (6)	20 x 25 x 2 (6)
Drain Size (NPT)	1"	1"	1"	1"	1"	1"
R-410A Refrigerant Charge Cir #1	186.2	186.2	186.2	186.2	186.2	186.2
R-410A Refrigerant Charge Cir #2	170.8	170.8	170.8	170.8	170.8	170.8
Evaporator Coil Face Area (ft <sup>2</sup> )	20	20	20	20	20	20
Rows Deep / Fins per Inch	4 / 16	4 / 16	4 / 16	4 / 16	4 / 16	4 / 16
<b>BELT DRIVE EVAP FAN DATA</b>						
# of Wheels (D x W)	2 (15" x 12")	2 (15" x 12")	2 (15" x 12")	2 (15" x 12")	2 (15" x 12")	2 (15" x 12")
Motor Sheave	1VP50 x 1½"	1VP60 x 1½"	1VP50 x 1½"	1VP60 x 1½"	1VP50 x 1½"	1VP60 x 1½"
Blower Sheave	BK90 x 1¾"	BK110 x 1¾"	BK90 x 1¾"	BK110 x 1¾"	BK90 x 1¾"	BK110 x 1¾"
Belt	BX42	BX48	BX42	BX48	BX42	BX48
<b>CONDENSER FAN / COIL</b>						
Quantity of Condenser Fan Motors	3	3	3	3	3	3
Horsepower - RPM	½ - 1,075	½ - 1,075	½ - 1,075	½ - 1,075	½ - 1,075	½ - 1,075
Fan Diameter / # Fan Blades	22 / 3	22 / 3	22 / 3	22 / 3	22 / 3	22 / 3
Outdoor Nominal CFM	9,000	9,000	9,000	9,000	9,000	9,000
Face Area (ft <sup>2</sup> )	53.3	53.3	53.3	53.3	53.3	53.3
Rows Deep / Fins per Inch	2 / 27	2 / 27	2 / 27	2 / 27	2 / 27	2 / 27
<b>COMPRESSOR</b>						
Quantity / Type	2 / Scroll	2 / Scroll	2 / Scroll	2 / Scroll	2 / Scroll	2 / Scroll
Compressor RLA / LRA Circuit #1	25 / 164	25 / 164	12.2 / 100	12.2 / 100	9.0 / 78	9.0 / 78
Compressor RLA / LRA Circuit #2	25 / 164	25 / 164	12.2 / 100	12.2 / 100	9.0 / 78	9.0 / 78
<b>ELECTRICAL DATA</b>						
Voltage / Phase (60 Hz)	208-230/ 3	208-230/ 3	460/ 3	460/ 3	575/ 3	575/ 3
Outdoor Fan FLA / LRA	2.0/4.4	2.0/4.4	.9/2.2	.9/2.2	.9 / 2.2	.9 / 2.2
Total Unit Amps	68.7	70	33.5	33.7	25.8	25.9
Min. Circuit Ampacity <sup>1</sup>	75	76.3	36.8	37	28	28
Max. Overcurrent Protection (amps) <sup>2</sup>	90	100	45	45	35	35
Entrance Power Supply	2½"	2½"	2½"	2½"	2½"	2½"
Entrance Control Voltage	¾"	¾"	¾"	¾"	¾"	¾"
<b>OPERATING WEIGHT (LBS)</b>	2083	2083	2083	2083	2083	2083
<b>SHIP WEIGHT (LBS)</b>	2198	2198	2198	2198	2198	2198

<sup>1</sup> Wire size should be determined in accordance with National Electrical Codes. Extensive wire runs will require larger wire sizes.

<sup>2</sup> May use fuses or HACR-type circuit breakers of the same size as noted.

Note: Always check the S&R plate for electrical data on the unit being installed.

PRODUCT SPECIFICATIONS — 20 TONS

	DCG240 4003B***A*	DCG240 4003V***A*	DCG240 4004B***A*	DCG240 4004V***A*	DCG240 4007B***A*	DCG240 4007V***A*
<b>COOLING CAPACITY</b>						
Total, BTU/h	240,000	240,000	240,000	240,000	240,000	240,000
Sensible BTU/h	170,000	170,000	170,000	170,000	170,000	170,000
EER / IEER	9.8 / 10.0	9.8 / 11.3	9.8 / 10.0	9.8 / 11.3	9.8 / 10.0	9.8 / 11.3
Decibels	88.3	88.3	88.3	88.3	88.3	88.3
AHRI Reference #s	6502024	6502021	6502024	6502021	6502024	6502021
<b>HEATING CAPACITY</b>						
High Input / Output (KBTU/h)	400 / 320	400 / 320	400 / 320	400 / 320	400 / 320	400 / 320
Low Input / Output (KBTU/h)	300 / 240	300 / 240	300 / 240	300 / 240	300 / 240	300 / 240
Steady State Efficiency (%)	80	80	80	80	80	80
Temperature Rise Range (°F) High/Low	25-55 / 15-45	25-55 / 15-45	25-55 / 15-45	25-55 / 15-45	25-55 / 15-45	25-55 / 15-45
No. of Burners	8	8	8	8	8	8
<b>EVAPORATOR MOTOR / COIL</b>						
Motor Type (Belt Drive)	Std Static	2-Speed Belt	Std Static	2-Speed Belt	Std Static	2-Speed Belt
Indoor Nominal CFM	7,000	7,000	7,000	7,000	7,000	7,000
Indoor Motor FLA (Cooling)	12.7	14	6.4	6.6	5.1	5.2
Horsepower - RPM	5.0 - 1,725	5.0 - 1,775/1185	5.0 - 1,725	5.0 - 1,775/1185	5.0 - 1,725	5.0 - 1,750/1185
Metering Device	TXV	TXV	TXV	TXV	TXV	TXV
Filter Size (#)	20 x 25 x 2 (6)	20 x 25 x 2 (6)	20 x 25 x 2 (6)	20 x 25 x 2 (6)	20 x 25 x 2 (6)	20 x 25 x 2 (6)
Drain Size (NPT)	1"	1"	1"	1"	1"	1"
R-410A Refrigerant Charge Cir #1	200 ozs.	200 ozs.	200 ozs.	200 ozs.	200 ozs.	200 ozs.
R-410A Refrigerant Charge Cir #2	200 ozs.	200 ozs.	200 ozs.	200 ozs.	200 ozs.	200 ozs.
Evaporator Coil Face Area (ft <sup>2</sup> )	20	20	20	20	20	20
Rows Deep / Fins per Inch	4 / 16	4 / 16	4 / 16	4 / 16	4 / 16	4 / 16
<b>BELT DRIVE EVAP FAN DATA</b>						
# of Wheels (D x W)	2 (15" x 15")	2 (15" x 15")	2 (15" x 15")	2 (15" x 15")	2 (15" x 15")	2 (15" x 15")
Motor Sheave	1VP60 x 1½"	1VP60 x 1½"	1VP60 x 1½"	1VP60 x 1½"	1VP60 x 1½"	1VP60 x 1½"
Blower Sheave	BK100 x 7/16"	BK100 x 17/16"	BK100 x 7/16"	BK100 x 17/16"	BK100 x 7/16"	BK100 x 17/16"
Belt	BX46	BX45	BX46	BX45	BX46	BX45
<b>CONDENSER FAN / COIL</b>						
Quantity of Condenser Fan Motors	3	3	3	3	3	3
Horsepower - RPM	½ - 1,075	½ - 1,075	½ - 1,075	½ - 1,075	½ - 1,075	½ - 1,075
Fan Diameter / # Fan Blades	22 / 3	22 / 3	22 / 3	22 / 3	22 / 3	22 / 3
Outdoor Nominal CFM	9,000	9,000	9,000	9,000	9,000	9,000
Face Area (ft <sup>2</sup> )	53.3	53.3	53.3	53.3	53.3	53.3
Rows Deep / Fins per Inch	2 / 27	2 / 27	2 / 27	2 / 27	2 / 27	2 / 27
<b>COMPRESSOR</b>						
Quantity / Type	2 / Scroll	2 / Scroll	2 / Scroll	2 / Scroll	2 / Scroll	2 / Scroll
Compressor RLA / LRA Circuit #1	33.3 / 239	33.3 / 239	17.9 / 125	17.9 / 125	12.8 / 80	12.8 / 80
Compressor RLA / LRA Circuit #2	33.3 / 239	33.3 / 239	17.9 / 125	17.9 / 125	12.8 / 80	12.8 / 80
<b>ELECTRICAL DATA / STATIC</b>						
Voltage / Phase (60 Hz)	208-230/ 3	208-230/ 3	460/ 3	460/ 3	575/ 3	575/ 3
Outdoor Fan FLA / LRA	2.0/4.4	2.0/4.4	.9/2.2	.9/2.2	.9 / 2.2	.9 / 2.2
Total Unit Amps	85.3	86.6	44.9	45.1	33.4	33.5
Min. Circuit Ampacity <sup>1</sup>	94	95	49	50	37	37
Max. Overcurrent Protection (amps) <sup>2</sup>	125	125	60	60	45	45
Entrance Power Supply	2½"	2½"	2½"	2½"	2½"	2½"
Entrance Control Voltage	¾"	¾"	¾"	¾"	¾"	¾"
<b>OPERATING WEIGHT (LBS)</b>						
	2242	2242	2242	2242	2242	2242
<b>SHIP WEIGHT (LBS)</b>						
	2357	2357	2357	2357	2357	2357

<sup>1</sup> Wire size should be determined in accordance with National Electrical Codes. Extensive wire runs will require larger wire sizes.

<sup>2</sup> May use fuses or HACR-type circuit breakers of the same size as noted.

Note: Always check the S&R plate for electrical data on the unit being installed.

EXPANDED COOLING DATA — 15 TONS (Standard motor and two-speed motor at high speed)

IDB		OUTDOOR AMBIENT TEMPERATURE																																			
		65						75						85						95						105						115					
		AIRFLOW		59	63	67	71	59	63	67	71	59	63	67	71	59	63	67	71	59	63	67	71	59	63	67	71	59	63	67	71						
70	6075	MBh	176.4	182.8	200.3	-	172.3	178.6	195.6	-	168.2	174.3	191.0	-	164.1	170.1	186.3	-	155.9	161.6	177.0	-	144.4	149.7	164.0	-	140.2	145.3	159.2	-							
		S/T	0.71	0.59	0.41	-	0.74	0.62	0.43	-	0.76	0.63	0.44	-	0.78	0.65	0.45	-	0.81	0.68	0.47	-	0.82	0.68	0.47	-	0.78	0.65	0.45	-							
		ΔT	19	16	12	-	19	17	13	-	19	17	13	-	19	17	13	-	19	17	13	-	18	15	12	-	19	16	12	-							
		HI PR	234	252	266	-	262	282	298	-	298	321	339	-	340	366	386	-	382	411	434	-	422	454	480	-	418	450	475	-							
		LO PR	102	109	119	-	108	115	126	-	112	120	131	-	118	126	137	-	124	132	144	-	128	136	149	-	127	135	147	-							
		MBh	171.2	177.5	194.5	-	167.3	173.4	189.9	-	163.3	169.2	185.4	-	159.3	165.1	180.9	-	151.3	156.9	171.9	-	140.2	145.3	159.2	-	136.1	141.2	155.2	-							
	S/T	0.68	0.57	0.39	-	0.70	0.59	0.41	-	0.72	0.60	0.42	-	0.74	0.62	0.43	-	0.77	0.65	0.45	-	0.78	0.65	0.45	-	0.74	0.62	0.43	-								
	ΔT	20	17	13	-	20	17	13	-	20	17	13	-	20	17	13	-	20	17	13	-	19	16	12	-	20	17	13	-								
	HI PR	231	249	263	-	260	279	295	-	295	318	336	-	336	362	382	-	378	407	430	-	418	450	475	-	418	450	475	-								
	LO PR	101	108	118	-	107	114	124	-	111	118	129	-	117	124	136	-	122	130	142	-	127	135	147	-	127	135	147	-								
	4320	MBh	158.1	163.8	179.5	-	154.4	160.0	175.3	-	150.7	156.2	171.1	-	147.0	152.4	167.0	-	139.7	144.8	158.6	-	129.4	134.1	146.9	-	125.4	130.1	142.9	-							
		S/T	0.65	0.55	0.38	-	0.68	0.57	0.39	-	0.70	0.58	0.40	-	0.72	0.60	0.42	-	0.74	0.62	0.43	-	0.75	0.63	0.43	-	0.71	0.59	0.41	-							
ΔT		22	19	14	-	22	19	15	-	22	19	15	-	22	19	15	-	22	19	15	-	21	18	14	-	21	18	14	-								
HI PR		224	242	255	-	252	271	286	-	286	308	326	-	326	351	371	-	367	395	417	-	406	436	461	-	406	436	461	-								
LO PR		98	105	114	-	104	110	121	-	108	115	125	-	113	121	132	-	119	126	138	-	123	131	143	-	123	131	143	-								
MBh		179.4	184.7	199.9	214.5	175.2	180.4	195.3	209.6	171.0	176.1	190.6	204.6	166.9	171.8	186.0	199.6	158.5	163.2	176.7	189.6	146.8	151.2	163.6	175.6												
75	6075	S/T	0.81	0.72	0.55	0.35	0.84	0.75	0.57	0.37	0.86	0.77	0.58	0.37	0.89	0.79	0.60	0.39	0.92	0.82	0.62	0.40	0.93	0.83	0.63	0.40											
		ΔT	22	20	17	11	22	20	17	12	22	20	17	12	22	21	17	12	22	20	17	12	21	19	16	11											
		HI PR	236	254	268	280	265	285	301	314	301	324	342	357	343	369	390	407	386	415	439	458	427	459	485	506											
		LO PR	103	110	120	128	109	116	127	135	114	121	132	140	119	127	138	147	125	133	145	155	129	138	150	160											
		MBh	174.2	179.3	194.1	208.3	170.1	175.1	189.6	203.5	166.1	171.0	185.1	198.6	162.0	166.8	180.5	193.8	153.9	158.5	171.5	184.1	142.6	146.8	158.9	170.5											
		S/T	0.77	0.69	0.52	0.34	0.80	0.71	0.54	0.35	0.82	0.73	0.55	0.36	0.85	0.76	0.57	0.37	0.88	0.79	0.59	0.38	0.89	0.79	0.60	0.39											
4320	6075	ΔT	23	21	17	12	23	21	17	12	23	21	17	12	23	21	18	12	23	21	17	12	21	20	16	11											
		HI PR	234	252	266	277	262	282	298	311	298	321	339	354	340	366	386	403	382	411	434	453	422	454	480	501											
		LO PR	102	109	119	127	108	115	126	134	112	120	131	139	118	126	137	146	124	132	144	153	128	136	149	158											
		MBh	160.7	165.5	179.1	192.3	157.0	161.6	175.0	187.8	153.3	157.8	170.8	183.3	149.5	154.0	166.6	178.8	142.0	146.3	158.3	169.9	131.6	135.5	146.6	157.4											
		S/T	0.74	0.67	0.50	0.32	0.77	0.69	0.52	0.34	0.79	0.71	0.53	0.34	0.82	0.73	0.55	0.36	0.85	0.76	0.57	0.37	0.85	0.76	0.58	0.37											
		ΔT	25	23	19	13	26	24	19	13	26	24	19	13	26	24	20	14	26	24	19	13	24	22	18	12											
HI PR	227	244	258	269	254	274	289	302	289	311	329	343	330	355	375	391	371	399	421	439	410	441	466	486													
LO PR	99	106	115	123	105	112	122	130	109	116	127	135	115	122	133	142	120	128	139	148	124	132	144	154													

IDB: Entering Indoor Dry Bulb Temperature  
 Shaded area reflects ACCA (TVA) conditions  
 High and low pressures are measured at the liquid and suction access fittings.

EXPANDED COOLING DATA — 15 TONS (Standard motor and two-speed motor at high speed)

IDB		OUTDOOR AMBIENT TEMPERATURE																																			
		65						75						85						95						105						115					
		ENTERING INDOOR WET BULB TEMPERATURE																																			
AIRFLOW	59	63	67	71	59	63	67	71	59	63	67	71	59	63	67	71	59	63	67	71	59	63	67	71	59	63	67	71	59	63	67	71					
<b>6075</b>	MBh	182.6	186.5	199.3	213.1	178.3	182.2	194.7	208.1	174.1	177.9	190.0	203.1	169.8	173.5	185.4	198.2	161.3	164.9	176.1	188.3	149.4	152.7	163.2	174.4	149.4	152.7	163.2	174.4	149.4	152.7	163.2	174.4				
	S/T	0.89	0.83	0.68	0.51	0.92	0.86	0.70	0.52	0.94	0.88	0.72	0.54	1.00	0.91	0.74	0.56	1.00	0.95	0.77	0.58	1.00	0.95	0.78	0.58	1.00	0.95	0.78	0.58	1.00	0.95	0.78	0.58				
	ΔT	25	23	20	16	25	24	21	17	25	24	21	17	26	24	21	17	24	24	21	16	23	22	19	15	23	22	19	15	23	22	19	15				
	HI PR	238	257	271	283	268	288	304	317	304	328	346	361	347	373	394	411	390	420	443	462	431	464	490	511	431	464	490	511	431	464	490	511				
LO PR	104	111	121	129	110	117	128	136	115	122	133	142	120	128	140	149	126	134	147	156	131	139	152	161	131	139	152	161	131	139	152	161					
<b>80</b>	MBh	177.2	181.1	193.5	206.9	173.1	176.9	189.0	202.0	169.0	172.7	184.5	197.2	164.9	168.5	180.0	192.4	156.6	160.1	171.0	182.8	145.1	148.3	158.4	169.3	145.1	148.3	158.4	169.3	145.1	148.3	158.4	169.3				
	S/T	0.85	0.79	0.65	0.48	0.88	0.82	0.67	0.50	0.90	0.84	0.69	0.51	0.93	0.87	0.71	0.53	0.96	0.90	0.74	0.55	0.97	0.91	0.74	0.55	0.97	0.91	0.74	0.55	0.97	0.91	0.74	0.55				
	ΔT	26	24	21	17	26	25	22	17	26	25	22	17	26	25	22	17	26	25	21	17	24	23	20	16	24	23	20	16	24	23	20	16				
	HI PR	236	254	268	280	265	285	301	314	301	324	342	357	343	369	390	407	386	415	439	458	427	459	485	506	427	459	485	506	427	459	485	506				
LO PR	103	110	120	128	109	116	127	135	114	121	132	140	119	127	139	148	125	133	145	155	129	138	150	160	129	138	150	160	129	138	150	160					
<b>4320</b>	MBh	163.6	167.2	178.6	190.9	159.8	163.3	174.4	186.5	156.0	159.4	170.3	182.0	152.2	155.5	166.1	177.6	144.6	147.7	157.8	168.7	133.9	136.8	146.2	156.3	133.9	136.8	146.2	156.3	133.9	136.8	146.2	156.3				
	S/T	0.82	0.76	0.62	0.47	0.85	0.79	0.65	0.48	0.87	0.81	0.66	0.49	0.89	0.84	0.68	0.51	0.93	0.87	0.71	0.53	0.94	0.88	0.71	0.53	0.94	0.88	0.71	0.53	0.94	0.88	0.71	0.53				
	ΔT	28	27	24	19	29	28	24	19	29	28	24	19	29	28	24	19	29	27	24	19	27	26	22	18	27	26	22	18	27	26	22	18				
	HI PR	229	246	260	271	257	277	292	305	292	315	332	346	333	358	378	395	375	403	426	444	414	445	470	490	414	445	470	490	414	445	470	490				
LO PR	100	107	116	124	106	113	123	131	110	117	128	136	116	123	134	143	121	129	141	150	125	133	146	155	125	133	146	155	125	133	146	155					
<b>6075</b>	MBh	185.8	189.3	198.3	211.6	181.4	184.9	193.7	206.6	177.1	180.5	189.1	201.7	172.8	176.1	184.5	196.8	164.2	167.3	175.2	187.0	152.1	155.0	162.3	173.2	152.1	155.0	162.3	173.2	152.1	155.0	162.3	173.2				
	S/T	0.93	0.90	0.81	0.66	0.96	0.93	0.84	0.68	0.99	0.95	0.86	0.70	1.00	0.98	0.89	0.72	1.00	1.00	0.92	0.75	1.00	1.00	0.93	0.75	1.00	1.00	0.93	0.75	1.00	1.00	0.93	0.75				
	ΔT	26	26	24	21	26	26	25	21	26	26	25	21	26	26	25	21	25	25	24	21	23	23	23	20	23	23	23	20	23	23	23	20				
	HI PR	241	259	274	285	270	291	307	320	307	331	349	364	350	377	398	415	394	424	448	467	435	468	495	516	435	468	495	516	435	468	495	516				
LO PR	105	112	122	130	111	119	129	138	116	123	135	143	122	129	141	150	127	136	148	158	132	140	153	163	132	140	153	163	132	140	153	163					
<b>5400</b>	MBh	180.3	183.8	192.5	205.4	176.1	179.6	188.1	200.6	172.0	175.3	183.6	195.8	167.8	171.0	179.1	191.1	159.4	162.5	170.1	181.5	147.6	150.5	157.6	168.1	147.6	150.5	157.6	168.1	147.6	150.5	157.6	168.1				
	S/T	0.89	0.86	0.77	0.63	0.92	0.89	0.80	0.65	0.94	0.91	0.82	0.67	0.97	0.94	0.85	0.69	1.00	0.97	0.88	0.71	1.00	0.98	0.89	0.72	1.00	0.98	0.89	0.72	1.00	0.98	0.89	0.72				
	ΔT	27	27	25	22	28	27	26	22	28	27	26	22	28	27	26	22	27	27	25	22	25	25	24	21	25	25	24	21	25	25	24	21				
	HI PR	238	257	271	283	268	288	304	317	304	328	346	361	347	373	394	411	390	420	443	462	431	464	490	511	431	464	490	511	431	464	490	511				
LO PR	104	111	121	129	110	117	128	136	115	122	133	142	120	128	140	149	126	134	147	156	131	139	152	161	131	139	152	161	131	139	152	161					
<b>4320</b>	MBh	166.5	169.7	177.7	189.6	162.6	165.7	173.6	185.2	158.7	161.8	169.4	180.8	154.8	157.8	165.3	176.4	147.1	149.9	157.0	167.5	136.3	138.9	145.5	155.2	136.3	138.9	145.5	155.2	136.3	138.9	145.5	155.2				
	S/T	0.86	0.83	0.74	0.60	0.89	0.86	0.77	0.63	0.91	0.88	0.79	0.64	0.94	0.91	0.82	0.66	0.97	0.94	0.85	0.69	0.98	0.95	0.85	0.69	0.98	0.95	0.85	0.69	0.98	0.95	0.85	0.69				
	ΔT	30	30	28	24	31	30	29	25	31	30	29	25	31	30	29	25	30	30	28	25	28	28	26	23	28	28	26	23	28	28	26	23				
	HI PR	231	249	263	274	260	279	295	308	295	318	335	350	336	362	382	399	378	407	430	448	418	450	475	495	418	450	475	495	418	450	475	495				
LO PR	101	108	118	125	107	114	124	132	111	118	129	138	117	124	136	145	122	130	142	151	127	135	147	157	127	135	147	157	127	135	147	157					

IDB: Entering Indoor Dry Bulb Temperature  
 Shaded area reflects AHRI (TVA) conditions  
 High and low pressures are measured at the liquid and suction access fittings.

EXPANDED COOLING DATA — 20 TONS (Standard motor and two-speed motor at high speed)

IDB		OUTDOOR AMBIENT TEMPERATURE																																			
		65						75						85						95						105						115					
		AIRFLOW		59	63	67	71	59	63	67	71	59	63	67	71	59	63	67	71	59	63	67	71	59	63	67	71	59	63	67	71						
70	7875	MBh	235.2	243.8	267.1	-	229.7	238.1	260.9	-	224.2	232.4	254.6	-	218.8	226.8	248.4	-	207.8	215.4	236.0	-	192.5	199.5	218.6	-	186.9	193.7	212.3	-							
		S/T	0.71	0.59	0.41	-	0.74	0.62	0.43	-	0.76	0.63	0.44	-	0.78	0.65	0.45	-	0.81	0.68	0.47	-	0.82	0.68	0.47	-	0.78	0.65	0.45	-							
		ΔT	20	17	13	-	20	17	13	-	20	17	13	-	20	17	13	-	20	17	13	-	18	16	12	-	18	16	12	-							
		HI PR	268	289	305	-	301	324	342	-	343	369	389	-	390	420	443	-	439	472	499	-	485	522	551	-	480	517	546	-							
		LO PR	99	105	115	-	105	111	121	-	109	116	126	-	114	121	133	-	120	127	139	-	124	132	144	-	123	130	142	-							
		MBh	228.3	236.7	259.3	-	223.0	231.2	253.3	-	217.7	225.7	247.2	-	212.4	220.1	241.2	-	201.8	209.1	229.1	-	186.9	193.7	212.3	-	172.5	178.8	195.9	-							
	S/T	0.68	0.57	0.39	-	0.70	0.59	0.41	-	0.72	0.60	0.42	-	0.74	0.62	0.43	-	0.77	0.65	0.45	-	0.78	0.65	0.45	-	0.75	0.63	0.43	-								
	ΔT	20	18	13	-	21	18	14	-	21	18	14	-	21	18	14	-	20	18	13	-	19	17	13	-	19	17	13	-								
	HI PR	266	286	302	-	298	321	339	-	339	365	385	-	386	416	439	-	435	468	494	-	480	517	546	-	480	517	546	-								
	LO PR	98	104	114	-	104	110	120	-	108	115	125	-	113	120	131	-	118	126	138	-	123	130	142	-	123	130	142	-								
	5600	MBh	210.7	218.4	239.3	-	205.8	213.4	233.8	-	200.9	208.3	228.2	-	196.0	203.2	222.6	-	186.2	193.0	211.5	-	172.5	178.8	195.9	-	172.5	178.8	195.9	-							
		S/T	0.65	0.55	0.38	-	0.68	0.57	0.39	-	0.70	0.58	0.40	-	0.72	0.60	0.42	-	0.74	0.62	0.43	-	0.75	0.63	0.43	-	0.75	0.63	0.43	-							
ΔT		23	20	15	-	23	20	15	-	23	20	15	-	23	20	15	-	23	20	15	-	21	18	14	-	21	18	14	-								
HI PR		258	277	293	-	289	311	329	-	329	354	374	-	375	403	426	-	422	454	479	-	466	501	529	-	466	501	529	-								
LO PR		95	101	110	-	100	107	117	-	104	111	121	-	110	117	127	-	115	122	133	-	119	126	138	-	119	126	138	-								
MBh		239.2	246.2	266.5	286.1	233.6	240.5	260.3	279.4	228.0	234.8	254.1	272.8	222.5	229.1	247.9	266.1	216.0	222.4	240.7	258.4	205.2	211.3	228.7	245.4	190.1	195.7	211.8	227.4								
75	7875	S/T	0.81	0.72	0.55	0.35	0.84	0.75	0.57	0.37	0.86	0.77	0.58	0.37	0.89	0.79	0.60	0.39	0.85	0.76	0.57	0.37	0.88	0.79	0.59	0.38	0.89	0.79	0.60	0.39							
		ΔT	23	21	17	12	23	21	17	12	23	21	17	12	23	21	17	12	24	22	18	13	24	22	18	12	22	20	17	12							
		HI PR	271	292	308	321	304	327	346	361	346	372	393	410	394	424	448	467	443	477	504	526	439	473	499	520	485	522	551	575							
		LO PR	100	106	116	124	106	112	123	131	110	117	128	136	115	123	134	143	121	129	140	150	120	127	139	148	124	132	144	153							
		MBh	232.2	239.1	258.8	277.7	226.8	233.5	252.8	271.3	221.4	228.0	246.7	264.8	216.0	222.4	240.7	258.4	205.2	211.3	228.7	245.4	190.1	195.7	211.8	227.4	175.4	180.6	195.5	209.8							
		S/T	0.77	0.69	0.52	0.34	0.80	0.71	0.54	0.35	0.82	0.73	0.55	0.36	0.85	0.76	0.57	0.37	0.88	0.79	0.59	0.38	0.89	0.79	0.60	0.39	0.89	0.79	0.60	0.39							
ΔT	24	22	18	12	24	22	18	12	24	22	18	12	24	22	18	12	24	22	18	12	24	22	18	12	22	20	17	12									
HI PR	269	289	305	318	301	324	342	357	343	369	389	406	390	420	444	463	439	473	499	520	485	522	551	575	485	522	551	575									
LO PR	99	105	115	122	105	111	122	129	109	116	126	135	114	122	133	141	120	127	139	148	124	132	144	153	124	132	144	153									
5600	7875	MBh	214.3	220.7	238.8	256.3	209.3	215.5	233.3	250.4	204.4	210.4	227.7	244.4	199.4	205.3	222.2	238.5	189.4	195.0	211.1	226.5	175.4	180.6	195.5	209.8	175.4	180.6	195.5	209.8							
		S/T	0.74	0.67	0.50	0.32	0.77	0.69	0.52	0.34	0.79	0.71	0.53	0.34	0.82	0.73	0.55	0.36	0.85	0.76	0.57	0.37	0.85	0.76	0.57	0.37	0.85	0.76	0.57	0.37							
		ΔT	26	24	20	14	26	24	20	14	27	24	20	14	27	25	20	14	26	24	20	14	25	23	19	13	25	23	19	13							
		HI PR	260	280	296	309	292	315	332	346	332	358	378	394	379	407	430	449	426	458	484	505	471	506	535	558	471	506	535	558							
		LO PR	96	102	112	119	101	108	118	126	105	112	123	130	111	118	129	137	116	124	135	144	120	128	139	149	120	128	139	149							
		MBh	239.2	246.2	266.5	286.1	233.6	240.5	260.3	279.4	228.0	234.8	254.1	272.8	222.5	229.1	247.9	266.1	216.0	222.4	240.7	258.4	205.2	211.3	228.7	245.4	190.1	195.7	211.8	227.4							
5600	7875	S/T	0.81	0.72	0.55	0.35	0.84	0.75	0.57	0.37	0.86	0.77	0.58	0.37	0.89	0.79	0.60	0.39	0.85	0.76	0.57	0.37	0.88	0.79	0.59	0.38	0.89	0.79	0.60	0.39							
		ΔT	23	21	17	12	23	21	17	12	23	21	17	12	23	21	17	12	24	22	18	13	24	22	18	12	22	20	17	12							
		HI PR	271	292	308	321	304	327	346	361	346	372	393	410	394	424	448	467	443	477	504	526	439	473	499	520	485	522	551	575							
		LO PR	100	106	116	124	106	112	123	131	110	117	128	136	115	123	134	143	121	129	140	150	120	127	139	148	124	132	144	153							
		MBh	232.2	239.1	258.8	277.7	226.8	233.5	252.8	271.3	221.4	228.0	246.7	264.8	216.0	222.4	240.7	258.4	205.2	211.3	228.7	245.4	190.1	195.7	211.8	227.4	175.4	180.6	195.5	209.8							
		S/T	0.77	0.69	0.52	0.34	0.80	0.71	0.54	0.35	0.82	0.73	0.55	0.36	0.85	0.76	0.57	0.37	0.88	0.79	0.59	0.38	0.89	0.79	0.60	0.39	0.89	0.79	0.60	0.39							
ΔT	24	22	18	12	24	22	18	12	24	22	18	12	24	22	18	12	24	22	18	12	24	22	18	12	22	20	17	12									
HI PR	269	289	305	318	301	324	342	357	343	369	389	406	390	420	444	463	439	473	499	520	485	522	551	575	485	522	551	575									
LO PR	99	105	115	122	105	111	122	129	109	116	126	135	114	122	133	141	120	127	139	148	124	132	144	153	124	132	144	153									

IDB: Entering Indoor Dry Bulb Temperature  
 Shaded area reflects ACCA (TVA) conditions  
 High and low pressures are measured at the liquid and suction access fittings.



EXPANDED COOLING DATA — 20 TONS (Standard motor and two-speed motor at high speed)

IDB		OUTDOOR AMBIENT TEMPERATURE																																																																													
		65						75						85						95						105						115																																															
		ENTERING INDOOR WET BULB TEMPERATURE																																																																													
AIRFLOW	59	63	67	71	59	63	67	71	59	63	67	71	59	63	67	71	59	63	67	71	59	63	67	71	59	63	67	71	59	63	67	71																																															
7875	MBh	243.4	248.7	265.7	284.1	237.8	242.9	259.6	277.5	232.1	237.2	253.4	270.9	226.4	231.4	247.2	264.3	215.1	219.8	234.8	251.0	209.3	213.4	228.0	243.7	199.3	203.6	217.5	232.5	S/T	0.89	0.83	0.68	0.51	0.92	0.86	0.70	0.52	0.94	0.88	0.72	0.54	1.00	0.91	0.74	0.56	1.00	0.95	0.77	0.58	1.00	0.95	0.78	0.58																									
	ΔT	25	24	21	17	26	24	21	17	26	24	21	17	26	25	21	17	26	25	21	17	25	24	21	17	23	23	20	16	HI PR	274	295	311	325	307	331	349	364	350	376	397	414	398	428	452	472	448	482	509	531	495	533	562	587																									
7000	LO PR	101	107	117	125	107	114	124	132	111	118	129	137	117	124	135	144	122	130	142	151	122	130	142	151	126	134	147	156	MBh	236.3	241.5	258.0	275.8	230.8	235.9	252.0	269.4	225.3	230.3	246.0	263.0	219.8	224.6	240.0	256.6	208.8	213.4	228.0	243.7	193.5	197.7	211.2	225.8	S/T	0.85	0.79	0.65	0.48	0.88	0.82	0.67	0.50	0.90	0.84	0.69	0.51	0.93	0.87	0.71	0.53	0.96	0.90	0.74	0.55	0.97	0.91	0.74	0.55
	ΔT	26	25	22	17	27	25	22	18	27	25	22	18	27	26	22	18	26	25	22	18	26	25	22	18	25	24	21	16	HI PR	271	292	308	321	304	328	346	361	346	372	393	410	394	424	448	467	444	477	504	526	490	527	557	581																									
5600	LO PR	100	106	116	124	106	112	123	131	110	117	128	136	115	123	134	143	121	129	140	150	121	129	140	150	125	133	145	155	MBh	218.1	222.9	238.1	254.6	213.1	217.7	232.6	248.6	208.0	212.5	227.1	242.7	202.9	207.3	221.5	236.8	192.8	197.0	210.4	225.0	178.6	182.5	194.9	208.4	S/T	0.82	0.76	0.62	0.47	0.85	0.79	0.65	0.48	0.87	0.81	0.66	0.49	0.89	0.84	0.68	0.51	0.93	0.87	0.71	0.53	0.94	0.88	0.71	0.53
	ΔT	29	28	24	19	30	28	25	20	30	28	25	20	30	29	25	20	30	29	25	20	29	28	24	20	27	26	23	18	HI PR	263	283	299	312	295	318	335	350	336	361	382	398	382	412	435	453	430	463	489	510	475	512	540	563																									
85	LO PR	97	103	113	120	103	109	119	127	107	113	124	132	112	119	130	138	117	125	136	145	117	125	136	145	121	129	141	150	MBh	247.7	252.5	264.4	282.1	241.9	246.6	258.3	275.5	236.2	240.7	252.1	269.0	230.4	234.8	246.0	262.4	218.9	223.1	233.7	249.3	202.7	206.7	216.4	230.9	S/T	0.93	0.90	0.81	0.66	0.96	0.93	0.84	0.68	0.99	0.95	0.86	0.70	1.00	0.98	0.89	0.72	1.00	1.00	0.92	0.75	1.00	1.00	0.93	0.75
	ΔT	27	26	25	22	27	27	25	22	27	27	25	22	27	27	26	22	26	26	25	22	26	26	25	22	24	24	23	20	HI PR	277	298	314	328	310	334	353	368	353	380	401	419	402	433	457	477	452	487	514	536	500	538	568	592																									
7875	LO PR	102	109	119	126	108	115	125	133	112	119	130	139	118	125	137	146	123	131	143	153	123	131	143	153	128	136	148	158	MBh	240.5	245.1	256.7	273.9	234.9	239.4	250.7	267.5	229.3	233.7	244.8	261.1	223.7	228.0	238.8	254.8	212.5	216.6	226.9	242.0	196.8	200.6	210.1	224.2	S/T	0.89	0.86	0.77	0.63	0.92	0.89	0.80	0.65	0.94	0.91	0.82	0.67	0.97	0.94	0.85	0.69	1.00	0.97	0.88	0.71	1.00	0.98	0.89	0.72
	ΔT	28	28	26	23	28	28	26	23	28	28	26	23	29	28	27	23	28	28	26	23	28	28	26	23	26	26	24	21	HI PR	274	295	311	325	307	331	349	364	350	376	397	414	398	428	452	472	448	482	509	531	495	533	562	587																									
7000	LO PR	101	107	117	125	107	114	124	132	111	118	129	137	117	124	135	144	122	130	142	151	122	130	142	151	126	134	147	156	MBh	221.9	226.2	236.9	252.8	216.8	221.0	231.4	246.9	211.6	215.7	225.9	241.0	206.5	210.5	220.4	235.1	196.1	199.9	209.4	223.4	181.7	185.2	194.0	206.9	S/T	0.86	0.83	0.74	0.60	0.89	0.86	0.77	0.63	0.91	0.88	0.79	0.64	0.94	0.91	0.82	0.66	0.97	0.94	0.85	0.69	0.98	0.95	0.85	0.69
	ΔT	31	31	29	25	32	31	29	25	32	31	29	25	32	31	30	26	31	31	29	25	31	31	29	25	29	29	27	24	HI PR	266	286	302	315	298	321	339	353	339	365	385	402	386	416	439	458	435	468	494	515	480	517	546	569																									
5600	LO PR	98	104	114	121	104	110	120	128	108	114	125	133	113	120	131	140	118	126	138	147	118	126	138	147	123	130	142	152	MBh	221.9	226.2	236.9	252.8	216.8	221.0	231.4	246.9	211.6	215.7	225.9	241.0	206.5	210.5	220.4	235.1	196.1	199.9	209.4	223.4	181.7	185.2	194.0	206.9	S/T	0.86	0.83	0.74	0.60	0.89	0.86	0.77	0.63	0.91	0.88	0.79	0.64	0.94	0.91	0.82	0.66	0.97	0.94	0.85	0.69	0.98	0.95	0.85	0.69
	ΔT	31	31	29	25	32	31	29	25	32	31	29	25	32	31	30	26	31	31	29	25	31	31	29	25	29	29	27	24	HI PR	266	286	302	315	298	321	339	353	339	365	385	402	386	416	439	458	435	468	494	515	480	517	546	569																									

IDB: Entering Indoor Dry Bulb Temperature  
 Shaded area reflects AHRI (TVA) conditions  
 High and low pressures are measured at the liquid and suction access fittings.

# AIRFLOW DATA — 15 TONS

## STANDARD & TWO-SPEED BELT DRIVE AT HIGH SPEED

ESP In" H <sub>2</sub> O	Turns Open													
	0		1		2		3		4		5		6	
	CFM	BHP	CFM	BHP	CFM	BHP	CFM	BHP	CFM	BHP	CFM	BHP	CFM	BHP
0.2	---	---	---	---	---	---	0	6,827	2.6675	6,394	2.2792	5,982	1.9434	
0.4	---	---	---	---	7,079	3.2019	6,623	2.7551	6,161	2.3441	5,706	1.9787	5,271	1.6650
0.6	---	---	6,903	3.3168	6,405	2.8302	5,923	2.4063	5,434	2.0191	4,949	1.6776	---	---
0.8	6,717	3.4193	6,198	2.9169	5,668	2.4546	5,152	2.0544	---	---	---	---	---	---
1.0	5,975	2.9894	5,418	2.5110	---	---	---	---	---	---	---	---	---	---
1.2	5,147	2.5507	---	---	---	---	---	---	---	---	---	---	---	---

## HIGH-STATIC BELT DRIVE

ESP In" H <sub>2</sub> O	Turns Open													
	0		1		2		3		4		5		6	
	CFM	BHP	CFM	BHP	CFM	BHP	CFM	BHP	CFM	BHP	CFM	BHP	CFM	BHP
1.0	---	---	---	---	---	---	---	6,690	3.6895	6,008	3.0189	5,321	2.4323	
1.2	---	---	---	---	---	---	6,653	3.9517	5,922	3.2198	5,182	2.5787	---	---
1.4	---	---	---	---	6,634	2.8014	5,857	3.4408	5,056	2.7377	---	---	---	---
1.6	---	---	6,638	4.5544	5,808	2.4260	4,948	2.9127	---	---	---	---	---	---
1.8	6,683	4.9263	5,784	3.9520	4,855	2.0548	---	---	---	---	---	---	---	---
2.0	5,803	4.2723	4,788	3.3189	---	---	---	---	---	---	---	---	---	---

**NOTES**

- Airflow table represent dry coil with filters installed; SCFM correction factor for wet coil is 4%.
- Any adjustment made to the blower should not cause the motor to draw more than the motor rated RLA. Application that exceed the above could require a larger motor. Minimum rated SCFM is 350 per ton.
- Unit factory shipped with the sheave set at 2.5 turns open.

# AIRFLOW DATA — 20 TONS

## STANDARD & TWO-SPEED BELT DRIVE AT HIGH SPEED — DOWN SHOT

ESP In" H <sub>2</sub> O	Turns Open													
	0		1		2		3		4		5		6	
	CFM	BHP	CFM	BHP	CFM	BHP	CFM	BHP	CFM	BHP	CFM	BHP	CFM	BHP
0.2	---	---	---	---	9,359	4.9235	8,991	3.7928	8,621	3.5442	8,188	3.2694	7,826	3.0421
0.4	---	---	9,018	3.1834	8,632	4.3858	8,251	3.3897	7,867	3.1452	7,363	2.8481	6,992	2.6282
0.6	---	---	8,279	2.9618	7,879	3.8623	7,484	2.9949	7,085	2.7548	---	---	---	---
0.8	7,957	4.8180	7,513	2.7320	7,097	3.3548	---	---	---	---	---	---	---	---
1.0	7,179	4.2309	6,716	2.4930	---	---	---	---	---	---	---	---	---	---
1.2	6,368	3.6582	---	---	---	---	---	---	---	---	---	---	---	---

## HIGH-STATIC BELT DRIVE

ESP In" H <sub>2</sub> O	Turns Open													
	0		1		2		3		4		5		6	
	CFM	BHP	CFM	BHP	CFM	BHP	CFM	BHP	CFM	BHP	CFM	BHP	CFM	BHP
1.0	---	---	---	---	---	---	9,001	6.8290	8,394	6.0087	7,797	4.7808	7,227	4.2762
1.2	---	---	---	---	8,891	6.8284	8,262	6.1503	7,632	5.3530	7,012	4.1965	---	---
1.4	---	---	8,811	6.8641	8,148	6.1510	7,495	5.4811	6,841	4.7084	---	---	---	---
1.6	---	---	8,065	6.1877	7,377	5.4834	---	---	---	---	---	---	---	---
1.8	7,998	6.8862	7,290	5.5213	---	---	---	---	---	---	---	---	---	---
2.0	7,221	6.1024	---	---	---	---	---	---	---	---	---	---	---	---

**NOTES**

- Airflow table represent dry coil with filters installed; SCFM correction factor for wet coil is 4%.
- Any adjustment made to the blower should not cause the motor to draw more than the motor rated RLA. Application that exceed the above could require a larger motor. Minimum rated SCFM is 350 per ton.
- Unit factory shipped with the sheave set at 2.5 turns open.

DIMENSIONS

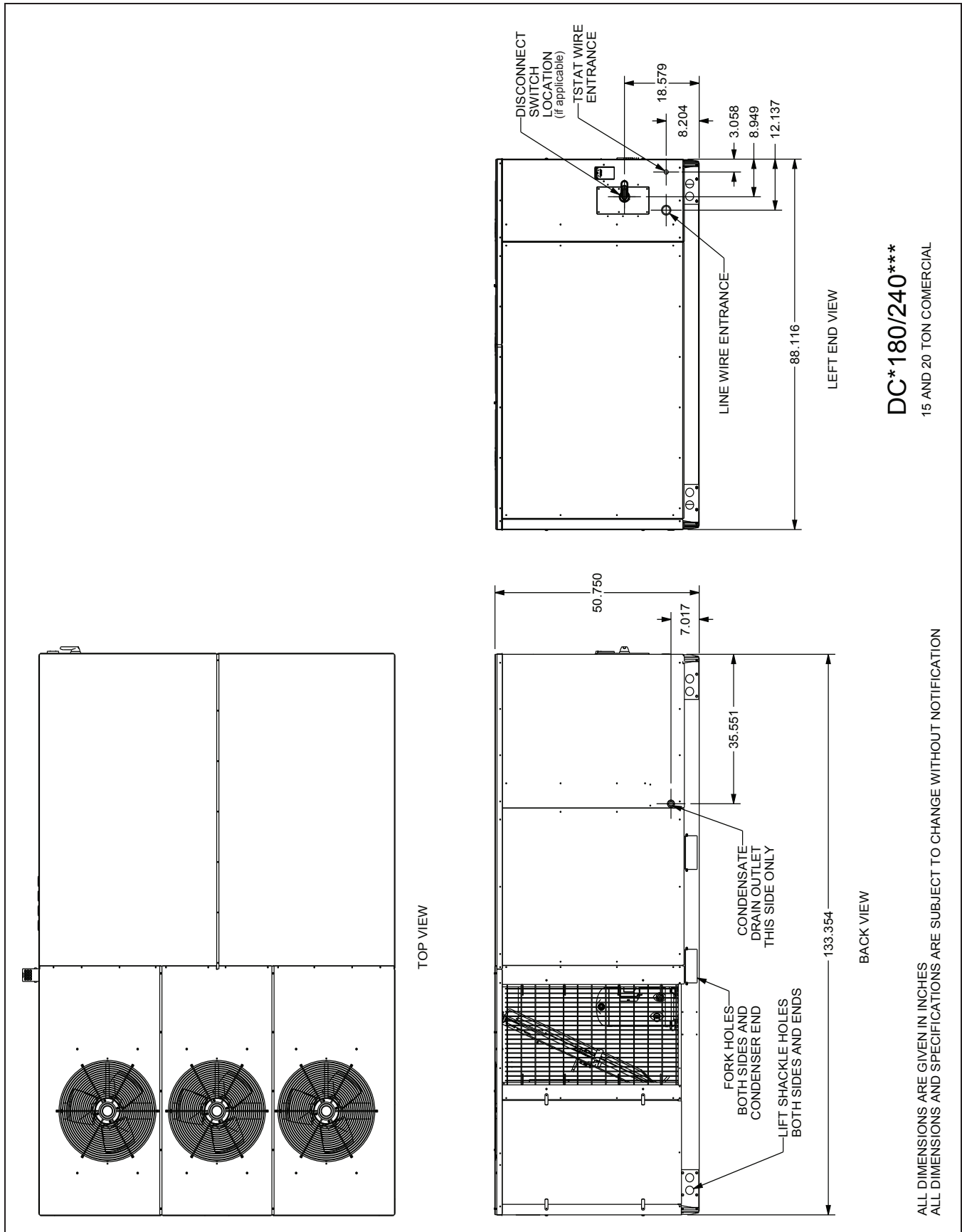

## UNIT CLEARANCES

Maintain an adequate clearance around the unit for safety, service, maintenance, and proper unit operation. Leave a total clearance of 75" on the main control panel side of the unit for possible removal of fan shaft, coil, electric heat, and gas furnace. Leave a clearance of 48" on all other sides of the unit for possible compressor removal or service access, and to ensure proper ventilation and condenser airflow. Do not install the unit beneath any obstruction. Install the unit away from all building exhausts to inhibit ingestion of exhaust air into the unit's fresh-air intake.

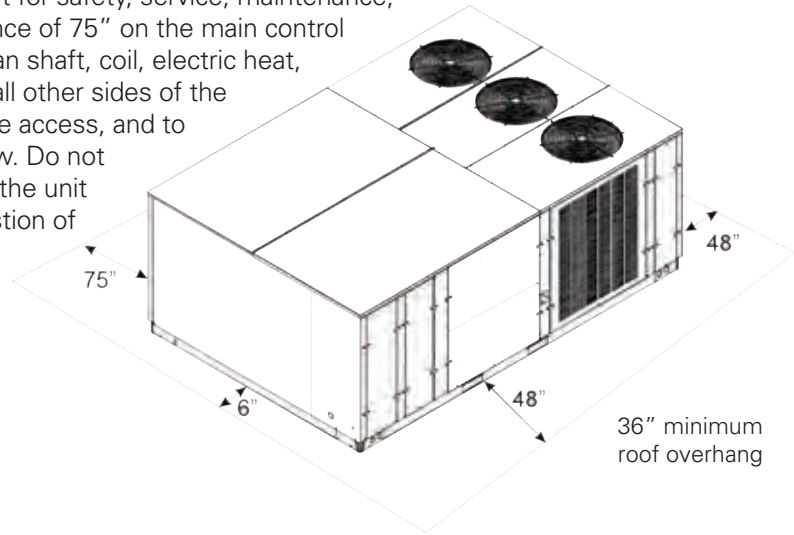

## ELECTRICAL ENTRANCE LOCATIONS

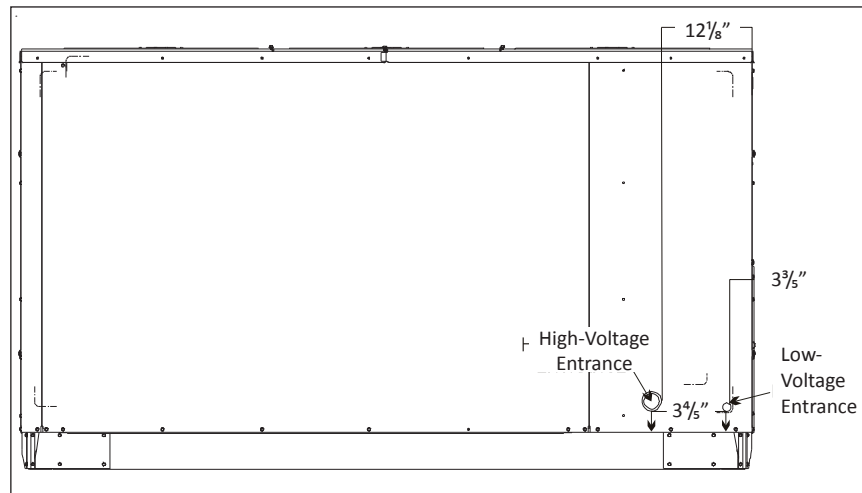

## ROOF CURB INSTALLATION — RIGGING

Provisions for forks have been included in the unit base frame. No other fork locations are approved.

- Unit must be lifted by the four lifting holes located at the base frame corners.
- Lifting cables should be attached to the unit with shackles.
- The distance between the crane hook and the top of the unit must not be less than 60".
- Two spreader bars must span over the unit to prevent damage to the cabinet by the lift cables. Spreader bars must be of sufficient length so that cables do not come in contact with the unit during transport. Remove wood struts mounted beneath unit base frame before setting unit on roof curb. These struts are intended to protect unit base frame from fork lift damage. To remove the struts, extract the sheet metal retainers and pull the struts through the base of the unit. Refer to rigging label on the unit.

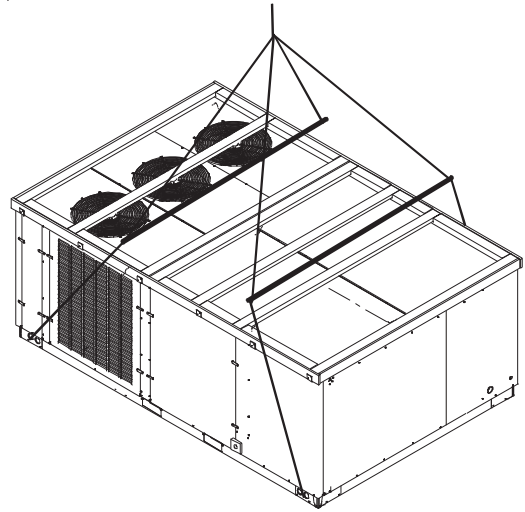

**Important:** If using bottom discharge with roof curb, duct-work should be attached to the curb prior to installing the unit. Duct-work dimensions are shown in Roof Curb Installation Instructions Manual.

Refer to the Roof Curb Installation Instructions for proper curb installation. Curbing must be installed in compliance with the National Roofing Contractors Association Manual.

Lower unit carefully onto roof mounting curb. While rigging the unit, the center of gravity will cause the condenser end to be lower than the supply air end.

Bring condenser end of unit into alignment with the curb. With condenser end of the unit resting on curb member and using curb as a fulcrum, lower opposite end of the unit until entire unit is seated on the curb. When a rectangular cantilever curb is used, take care to center the unit. Check for proper alignment and orientation of supply and return openings with duct.

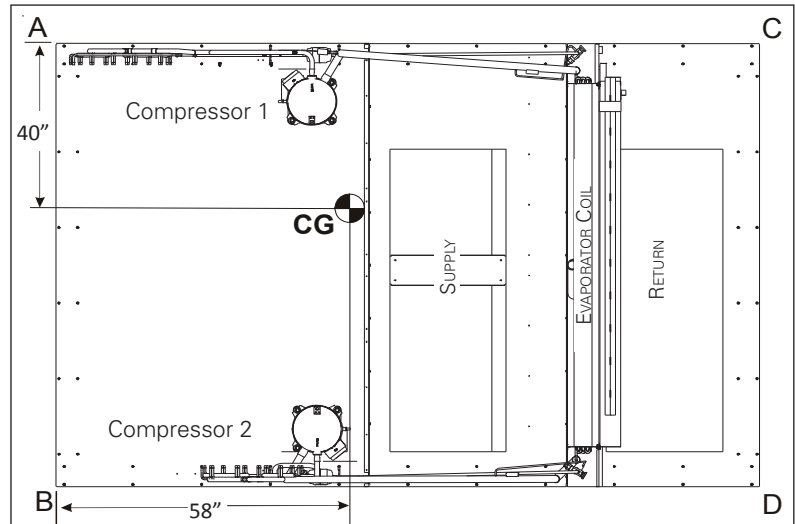

CORNER & CENTER-OF-GRAVITY LOCATIONS

15-TON UNITS	WEIGHTS
Weight A	582
Weight B	475
Weight C	565
Weight D	461
Shipping Weight	2198
Operating Weight	2083

20-TON UNITS	WEIGHTS
Weight A	645
Weight B	527
Weight C	589
Weight D	481
Shipping Weight	2357
Operating Weight	2242

To assist in determining rigging requirements, unit weights are shown to the right.

**Note:** These weights are calculated without installed accessories.

## ROOF CURB INSTALLATION

Curb installations must comply with local codes and should follow the established guidelines of the National Roofing Contractors Association.

Proper unit installation requires that the roof curb be firmly and permanently attached to the roof structure. Check for adequate fastening method prior to setting the unit on the curb.

Full perimeter roof curbs are available from the factory and are shipped unassembled. The installing contractor is responsible for field assembly, squaring, leveling, and mounting on the roof structure. All required hardware necessary for the assembly of the sheet metal curb is included in the curb accessory package.

- Determine sufficient structural support before locating and mounting the curb and package unit.
- Duct-work must be constructed using industry guidelines. The duct-work must be placed into the roof curb before mounting the package unit. Our full perimeter curbs include duct connection frames to be assembled with the curb. Cantilevered-type curbs are not available from the factory.
- Contractor furnishes curb insulation, cant strips, flashing, and general roofing material.
- Support curbs on parallel sides with roof members. To prevent damage to the unit, the roof members cannot penetrate supply and return duct openings.

**Note:** The unit and curb accessories are designed to allow vertical duct installation before unit placement. Duct installation after unit placement is not recommended.

See the manual shipped with the roof curb for assembly and installation instructions.

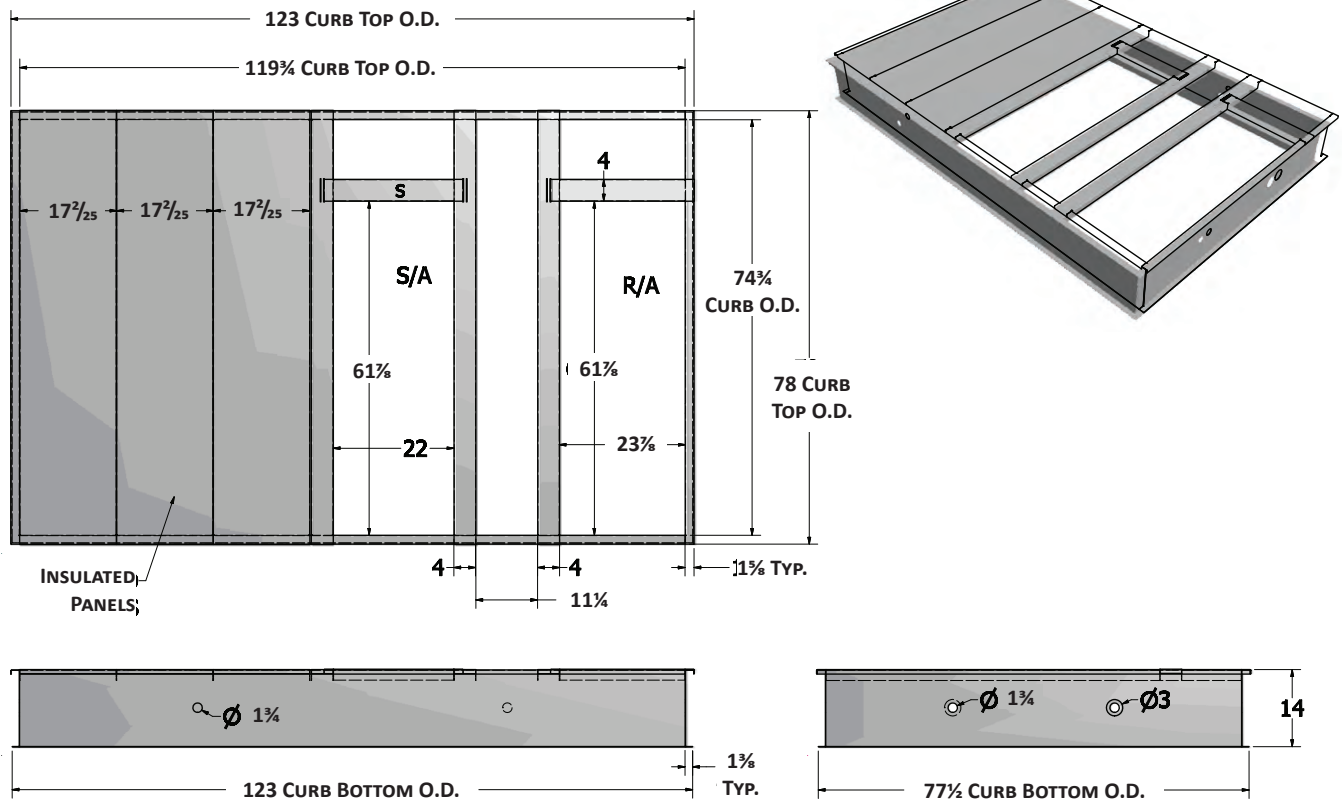

# WIRING DIAGRAM — DCG 15 & 20 TONS (230V THREE-PHASE BELT DRIVE)

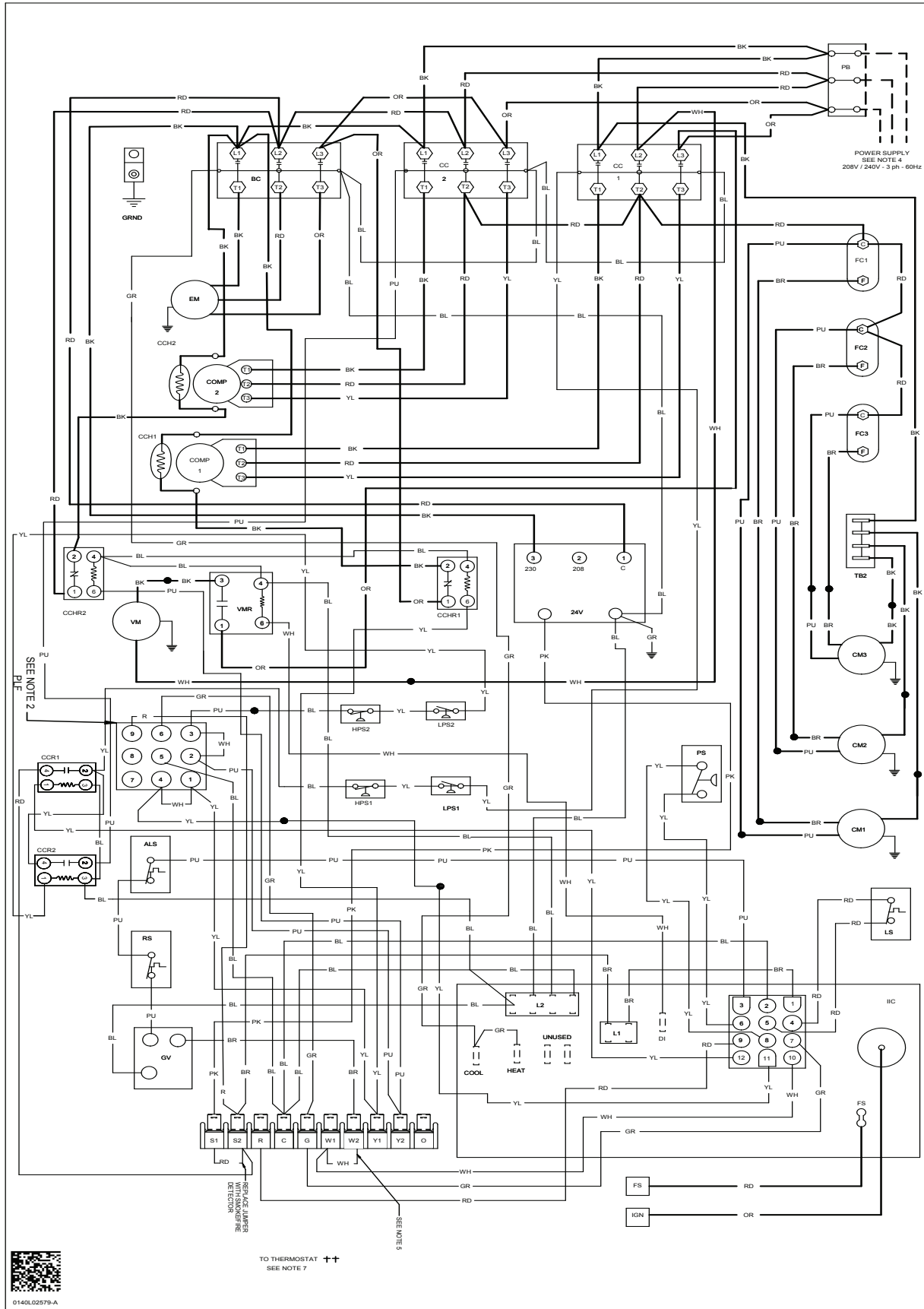

**High Voltage:** Disconnect all power before servicing or installing this unit. Multiple power sources may be present. Failure to do so may cause property damage, personal injury, or death.

**WARNING**

Wiring is subject to change. Always refer to the wiring diagram or the unit for the most up-to-date wiring.



# WIRING DIAGRAM — DCG 15 & 20 TONS (230V THREE-PHASE BELT DRIVE) CONT.

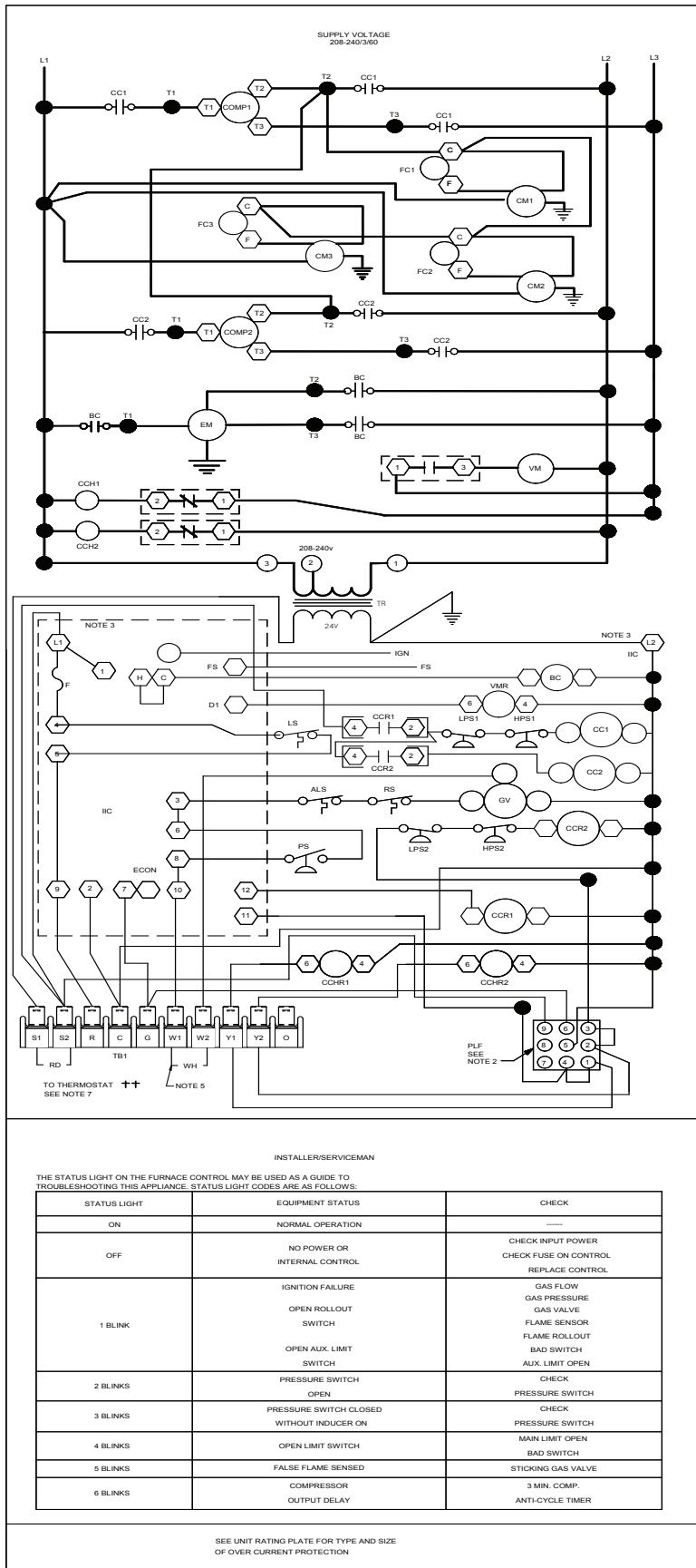

- COMPONENT LEGEND**
- ALS AUXILIARY LIMIT SWITCH
  - BC BLOWER CONTACTOR
  - COMP COMPRESSOR
  - CM CONDENSER MOTOR
  - CC COMPRESSOR CONTACTOR
  - CCH CRANK CASE HEATER
  - CCHR CRANK CASE HEATER RELAY
  - CCR COMPRESSOR CONTACTOR RELAY
  - EM EVAPORATOR MOTOR
  - F FUSE
  - FC FAN CAPACITOR
  - FS FLAME SENSOR
  - GND EQUIPMENT GROUND
  - GV GAS VALVE
  - HPS HIGH PRESSURE SWITCH
  - IBR INDOOR BLOWER RELAY
  - IIC INTEGRATED IGNITION CONTROL
  - IGN IGNITOR
  - LPS LOW PRESSURE SWITCH
  - LS LIMIT SWITCH
  - PB POWER DISTRIBUTION BLOCK
  - PLF FEMALE PLUG/CONNECTOR
  - PS PRESSURE SWITCH
  - RS ROLLOUT SWITCH
  - TB1 TERMINAL BLOCK (24V SIGNAL)
  - TB2 TERMINAL BLOCK (L1)
  - TR TRANSFORMER
  - VM VENT MOTOR
  - VMR VENT MOTOR RELAY

- NOTES**
- REPLACEMENT WIRE MUST BE THE SAME SIZE AND TYPE OF INSULATION AS ORIGINAL. (USE COPPER CONDUCTOR ONLY).
  - ACCESSORY ECONOMIZER PLUG ADJACENT TO BLOWER HOUSING IN RETURN AIR COMPARTMENT. REMOVE MALE PLUG AND ATTACH FEMALE PLUG TO THE ECONOMIZER ACCESSORY.
  - L1 AND L2 ON IIC CONTROL IS 24V INPUT.
  - USE COPPER CONDUCTORS ONLY.
  - FOR TWO STAGE OPERATION REMOVE W1 TO W2 WIRE JUMPER.
  - FOR 208V OPERATION MOVE BLACK WIRE FROM TERMINAL ① TO TERMINAL ② ON THE TRANSFORMER.
  - IF DDC CONTROL OPTION IS INSTALLED, THERMOSTAT FIELD WIRING IS NOT REQUIRED. SEE DDC CONTROL WIRING DIAGRAM AND INSTRUCTIONS.

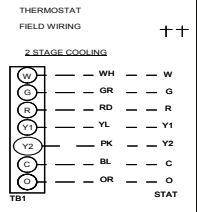
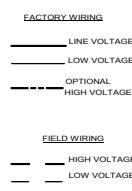

- WIRE CODE**
- BK BLACK
  - BL BLUE
  - BR BROWN
  - GR GREEN
  - OR ORANGE
  - PK PINK
  - PU PURPLE
  - RD RED
  - WH WHITE
  - YL YELLOW
  - YL/PK YELLOW WITH PINK STRIP
  - BL/PK BLUE WITH PINK STRIP

**High Voltage:** Disconnect all power before servicing or installing this unit. Multiple power sources may be present. Failure to do so may cause property damage, personal injury, or death.

**WARNING**

Wiring is subject to change. Always refer to the wiring diagram or the unit for the most up-to-date wiring.



# WIRING DIAGRAM — DCG 15 & 20 TONS (460V/ 575V THREE-PHASE BELT DRIVE)

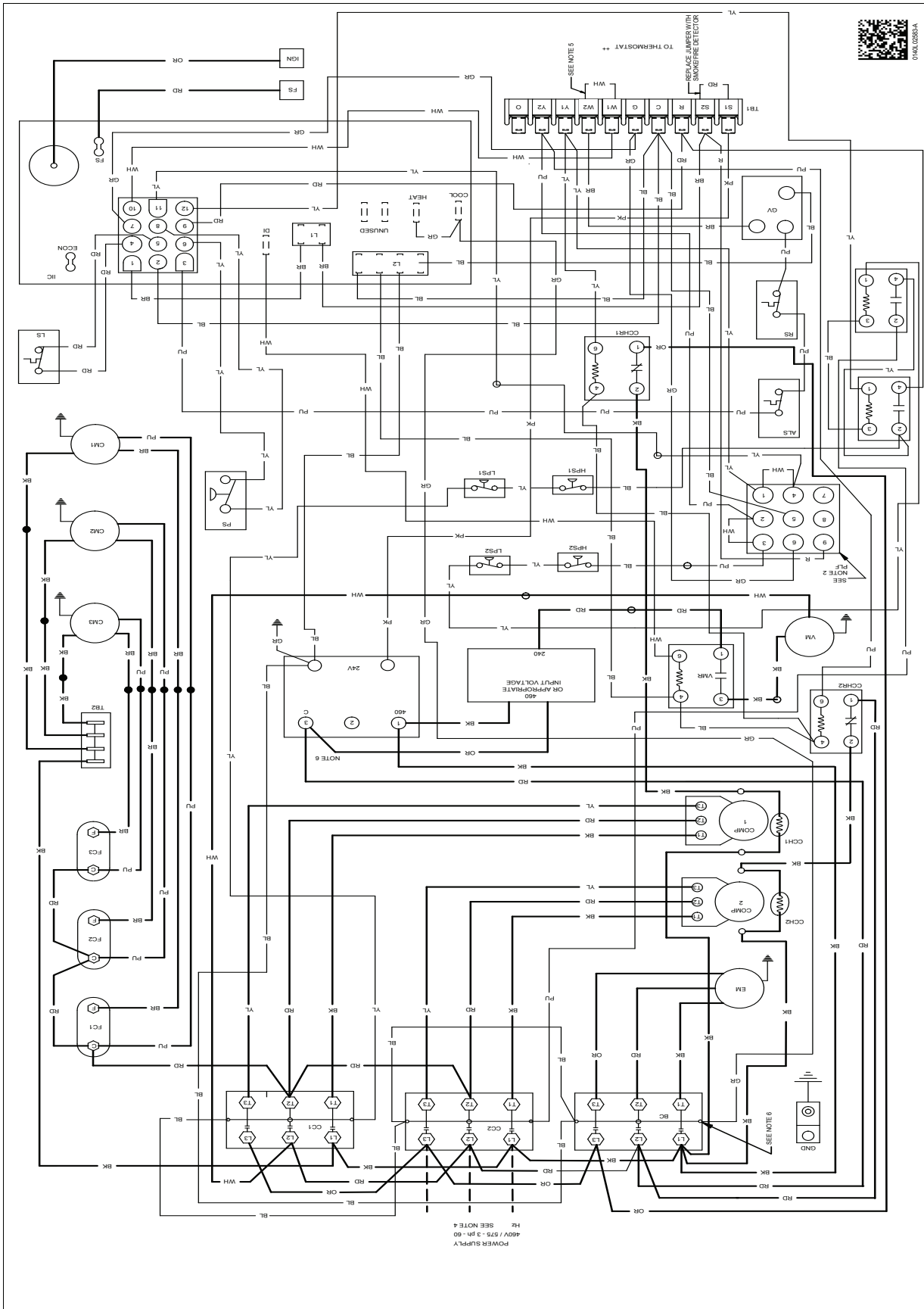

**WARNING**

**High Voltage:** Disconnect all power before servicing or installing this unit. Multiple power sources may be present. Failure to do so may cause property damage, personal injury, or death.

Wiring is subject to change. Always refer to the wiring diagram or the unit for the most up-to-date wiring.

# WIRING DIAGRAM — DCG 15 & 20 TONS (460V/ 575V THREE-PHASE BELT DRIVE) CONT.

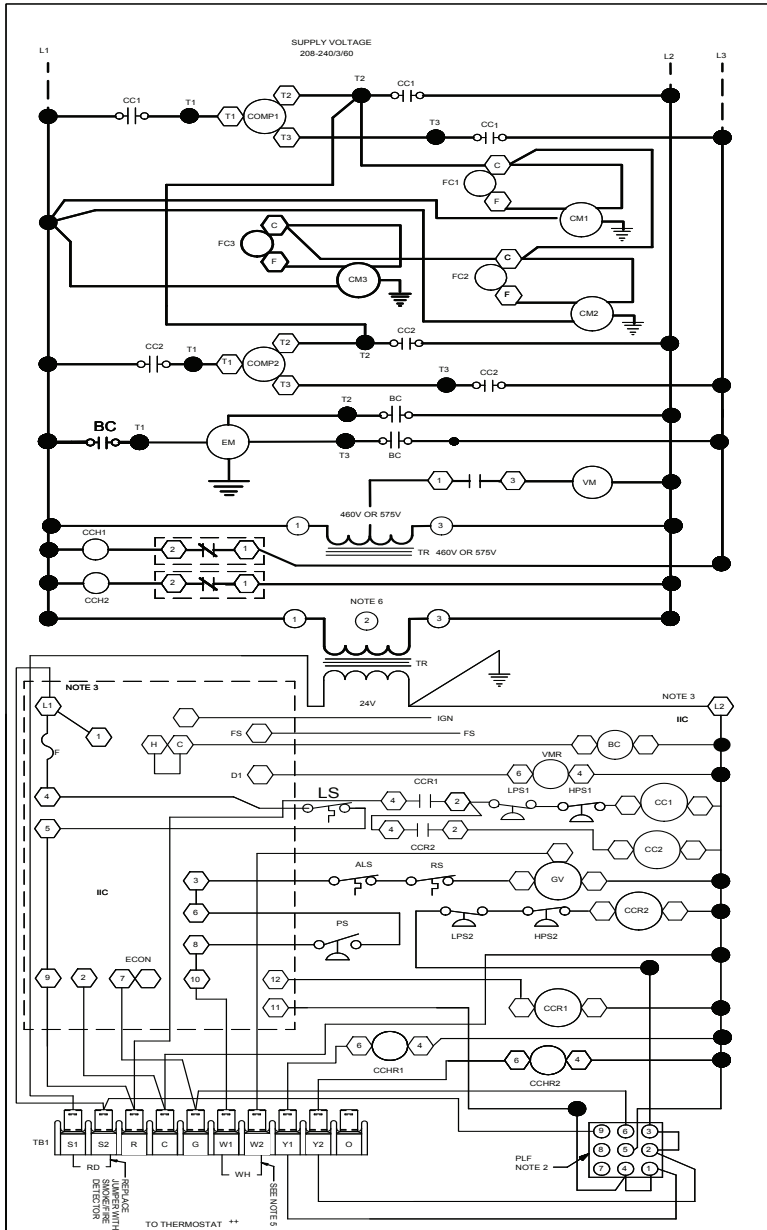

**COMPONENT LEGEND**

ALS	AUXILIARY LIMIT SWITCH
BC	BLOWER CONTACTOR
COMP	COMPRESSOR
CM	CONDENSER MOTOR
CC	COMPRESSOR CONTACTOR
CCH	CRANK CASE HEATER
CCHR	CRANK CASE HEATER RELAY
CCR	COMPRESSOR CONTACTOR RELAY
EM	EVAPORATOR MOTOR
F	FUSE
FC	FAN CAPACITOR
FS	FLAME SENSOR
GND	EQUIPMENT GROUND
GV	GAS VALVE
HPS	HIGH PRESSURE SWITCH
IBR	INDOOR BLOWER RELAY
IIC	INTEGRATED IGNITION CONTROL
IGN	IGNITOR
LPS	LOW PRESSURE SWITCH
LS	LIMIT SWITCH
PLF	FEMALE PLUG/CONNECTOR
PS	PRESSURE SWITCH
RS	ROLLOUT SWITCH
TB1	TERMINAL BLOCK (24V SIGNAL)
TB2	TERMINAL BLOCK (L1)
TR	TRANSFORMER
VM	VENT MOTOR
VMR	VENT MOTOR RELAY

- NOTES**
- REPLACEMENT WIRE MUST BE THE SAME SIZE AND TYPE OF INSULATION AS ORIGINAL. (USE COPPER CONDUCTOR ONLY).
  - ACCESSORY ECONOMIZER PLUG ADJACENT TO BLOWER HOUSING IN RETURN AIR COMPARTMENT. REMOVE MALE PLUG AND ATTACH FEMALE PLUG TO THE ECONOMIZER ACCESSORY.
  - L1 AND L2 ON IIC CONTROL IS 24V INPUT.
  - USE COPPER CONDUCTORS ONLY.  
+ + USE NEC CLASS 2 WIRE.
  - FOR TWO STAGE OPERATION REMOVE W1 TO W2 WIRE JUMPER.
  - FOR 575V OPERATION MOVE BLACK WIRE FROM TERMINAL ① TO TERMINAL ② ON 460V.

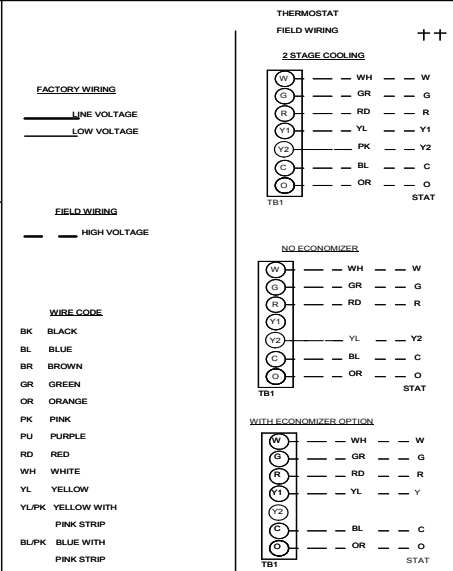

**High Voltage:** Disconnect all power before servicing or installing this unit. Multiple power sources may be present. Failure to do so may cause property damage, personal injury, or death.

**WARNING**

INSTALLER/SERVICEMAN

THE STATUS LIGHT ON THE FURNACE CONTROL MAY BE USED AS A GUIDE TO TROUBLESHOOTING THIS APPLIANCE. STATUS LIGHT CODES ARE AS FOLLOWS:

STATUS LIGHT	EQUIPMENT STATUS	CHECK
ON	NORMAL OPERATION	—
OFF	NO POWER OR INTERNAL CONTROL	CHECK INPUT POWER CHECK FUSE ON CONTROL REPLACE CONTROL
1 BLINK	IGNITION FAILURE OPEN ROLLOUT SWITCH OPEN AUX. LIMIT SWITCH	GAS FLOW GAS PRESSURE GAS VALVE FLAME SENSOR FLAME ROLLOUT BAD SWITCH AUX. LIMIT OPEN
2 BLINKS	PRESSURE SWITCH OPEN	CHECK PRESSURE SWITCH
3 BLINKS	PRESSURE SWITCH CLOSED WITHOUT INDUCER ON	CHECK PRESSURE SWITCH
4 BLINKS	OPEN LIMIT SWITCH	CHECK MAIN LIMIT OPEN BAD SWITCH
5 BLINKS	FALSE FLAME SENSED	STICKING GAS VALVE
6 BLINKS	COMPRESSOR OUTPUT DELAY	3 MIN. COMP. ANTI-CYCLE TIMER

SEE UNIT RATING PLATE FOR TYPE AND SIZE OF OVER CURRENT PROTECTION



0140L02584-A

Wiring is subject to change. Always refer to the wiring diagram or the unit for the most up-to-date wiring.



# WIRING DIAGRAM — DCG 15 & 20 TONS (230V TWO-SPEED BELT DRIVE) CONT.

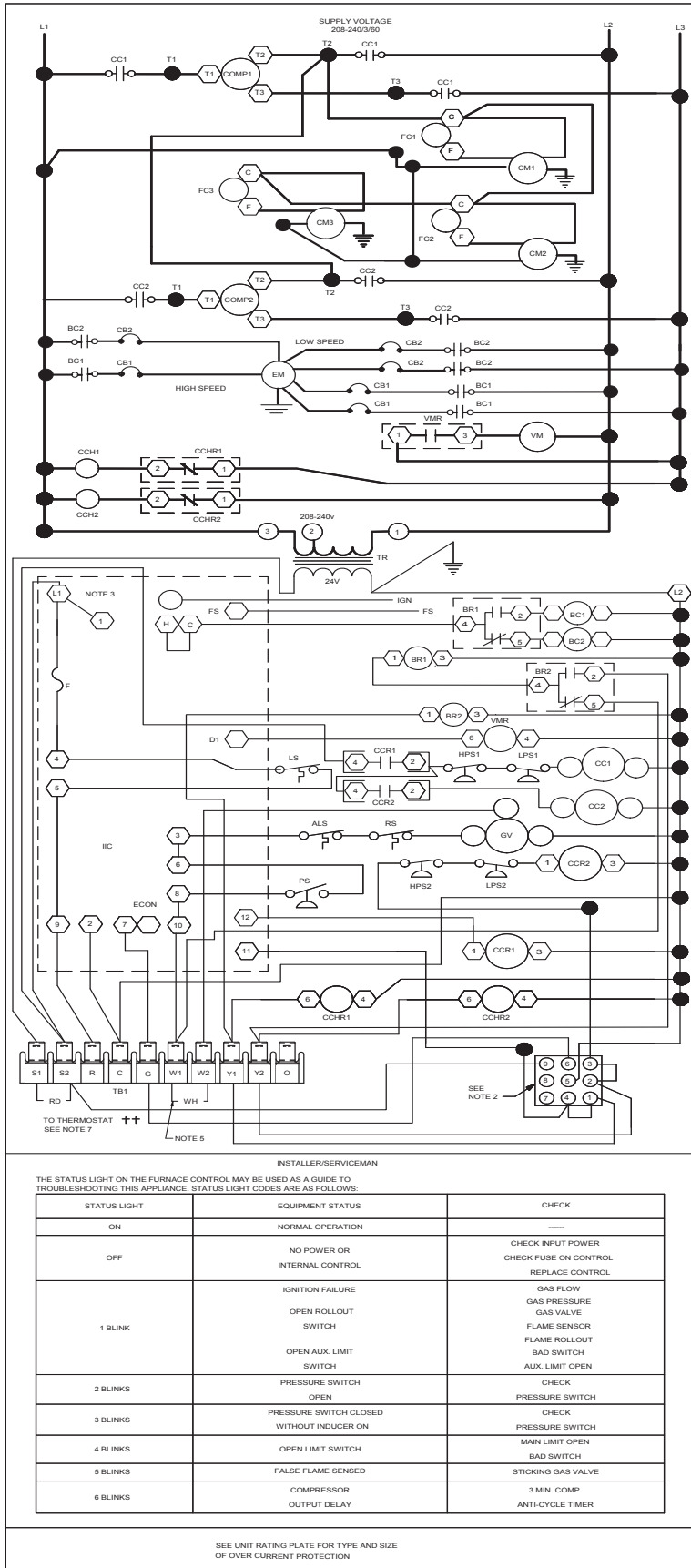

**COMPONENT LEGEND**

- ALS AUXILIARY LIMIT SWITCH
- BC BLOWER CONTACTOR
- BR BLOWER RELAY
- CB CIRCUIT BREAKER
- COMP COMPRESSOR
- CM CONDENSER MOTOR
- CC COMPRESSOR CONTACTOR
- CCH CRANK CASE HEATER
- CCHR CRANK CASE HEATER RELAY
- CCR COMPRESSOR CONTACTOR RELAY
- EM EVAPORATOR MOTOR
- F FUSE
- FC FAN CAPACITOR
- FS FLAME SENSOR
- GND EQUIPMENT GROUND
- GV GAS VALVE
- HPS HIGH PRESSURE SWITCH
- IBR INDOOR BLOWER RELAY
- IIC INTEGRATED IGNITION CONTROL
- IGN IGNITOR
- LPS LOW PRESSURE SWITCH
- LS LIMIT SWITCH
- PB POWER DISTRIBUTION BLOCK
- PLF FEMALE PLUG/CONNECTOR
- PS PRESSURE SWITCH
- RS ROLLOUT SWITCH
- TB1 TERMINAL BLOCK (24V SIGNAL)
- TB2 TERMINAL BLOCK (L-1)
- TR TRANSFORMER
- VM VENT MOTOR
- VMR VENT MOTOR RELAY

- NOTES**
- REPLACEMENT WIRE MUST BE THE SAME SIZE AND TYPE OF INSULATION AS ORIGINAL. (USE COPPER CONDUCTOR ONLY).
  - ACCESSORY ECONOMIZER PLUG ADJACENT TO BLOWER HOUSING IN RETURN AIR COMPARTMENT. REMOVE MALE PLUG AND ATTACH FEMALE PLUG TO THE ECONOMIZER ACCESSORY.
  - L1 AND L2 ON IIC CONTROL IS 24V INPUT.
  - USE COPPER CONDUCTORS ONLY.  
+ + USE NEC CLASS 2 WIRE.
  - FOR TWO STAGE OPERATION REMOVE W1 TO W2 WIRE JUMPER.
  - FOR 208V OPERATION MOVE BLACK WIRE FROM TERMINAL ① TO TERMINAL ② ON THE TRANSFORMER.

**FACTORY WIRING**

- LINE VOLTAGE
- LOW VOLTAGE
- - - OPTIONAL HIGH VOLTAGE

**FIELD WIRING**

- HIGH VOLTAGE
- - - LOW VOLTAGE

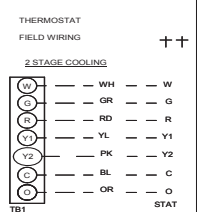

**WIRE CODE**

- BK BLACK
- BL BLUE
- BR BROWN
- GR GREEN
- OR ORANGE
- PK PINK
- PU PURPLE
- RD RED
- WH WHITE
- YL YELLOW
- YL/PK YELLOW WITH PINK STRIP
- BL/PK BLUE WITH PINK STRIP

INSTALLER/SERVICEMAN

THE STATUS LIGHT ON THE FURNACE CONTROL MAY BE USED AS A GUIDE TO TROUBLESHOOTING THIS APPLIANCE. STATUS LIGHT CODES ARE AS FOLLOWS:

STATUS LIGHT	EQUIPMENT STATUS	CHECK
ON	NORMAL OPERATION	---
OFF	NO POWER OR INTERNAL CONTROL	CHECK INPUT POWER CHECK FUSE ON CONTROL REPLACE CONTROL
1 BLINK	IGNITION FAILURE	GAS FLOW GAS PRESSURE GAS VALVE
	OPEN ROLLOUT SWITCH	FLAME SENSOR FLAME ROLLOUT BAD SWITCH
2 BLINKS	OPEN AUX. LIMIT SWITCH	AUX. LIMIT OPEN
	PRESSURE SWITCH OPEN	CHECK PRESSURE SWITCH
3 BLINKS	PRESSURE SWITCH CLOSED	CHECK PRESSURE SWITCH
	WITHOUT INDUCER ON	PRESSURE SWITCH MAIN LIMIT OPEN BAD SWITCH
4 BLINKS	OPEN LIMIT SWITCH	BAD SWITCH
5 BLINKS	FALSE FLAME SENSED	STICKING GAS VALVE
6 BLINKS	COMPRESSOR OUTPUT DELAY	3 MIN. COMP. ANTI-CYCLE TIMER

SEE UNIT RATING PLATE FOR TYPE AND SIZE OF OVER CURRENT PROTECTION

**High Voltage:** Disconnect all power before servicing or installing this unit. Multiple power sources may be present. Failure to do so may cause property damage, personal injury, or death.

**WARNING**

Wiring is subject to change. Always refer to the wiring diagram or the unit for the most up-to-date wiring.



0140L02914-A

# WIRING DIAGRAM — DCG 15 & 20 TONS (460V/ 575V TWO-SPEED BELT DRIVE)

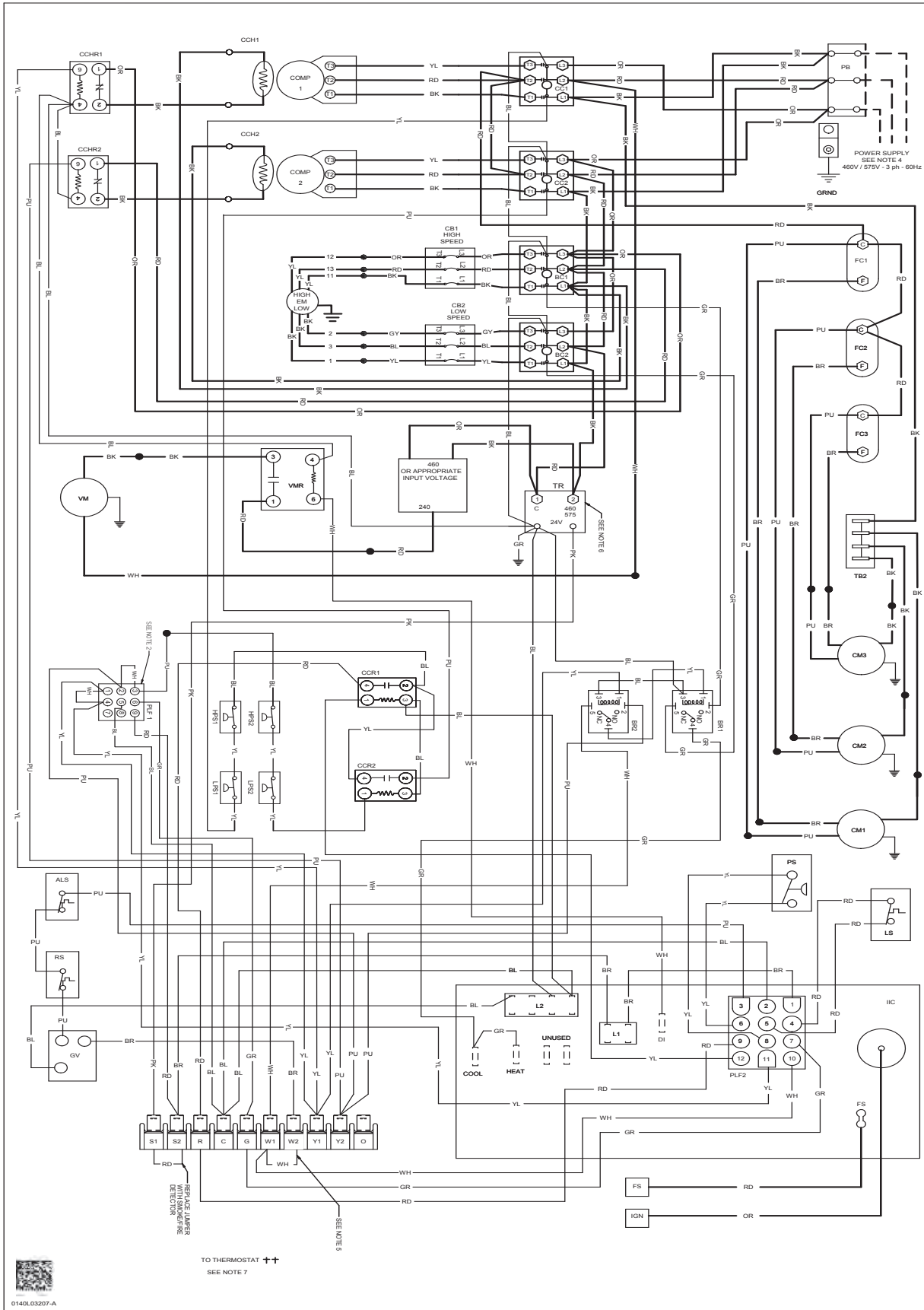

**WARNING**  
High Voltage: Disconnect all power before servicing or installing this unit. Multiple power sources may be present. Failure to do so may cause property damage, personal injury, or death.

Wiring is subject to change. Always refer to the wiring diagram or the unit for the most up-to-date wiring.

# WIRING DIAGRAM — DCG 15 & 20 TONS (460V/ 575V TWO-SPEED BELT DRIVE) CONT.

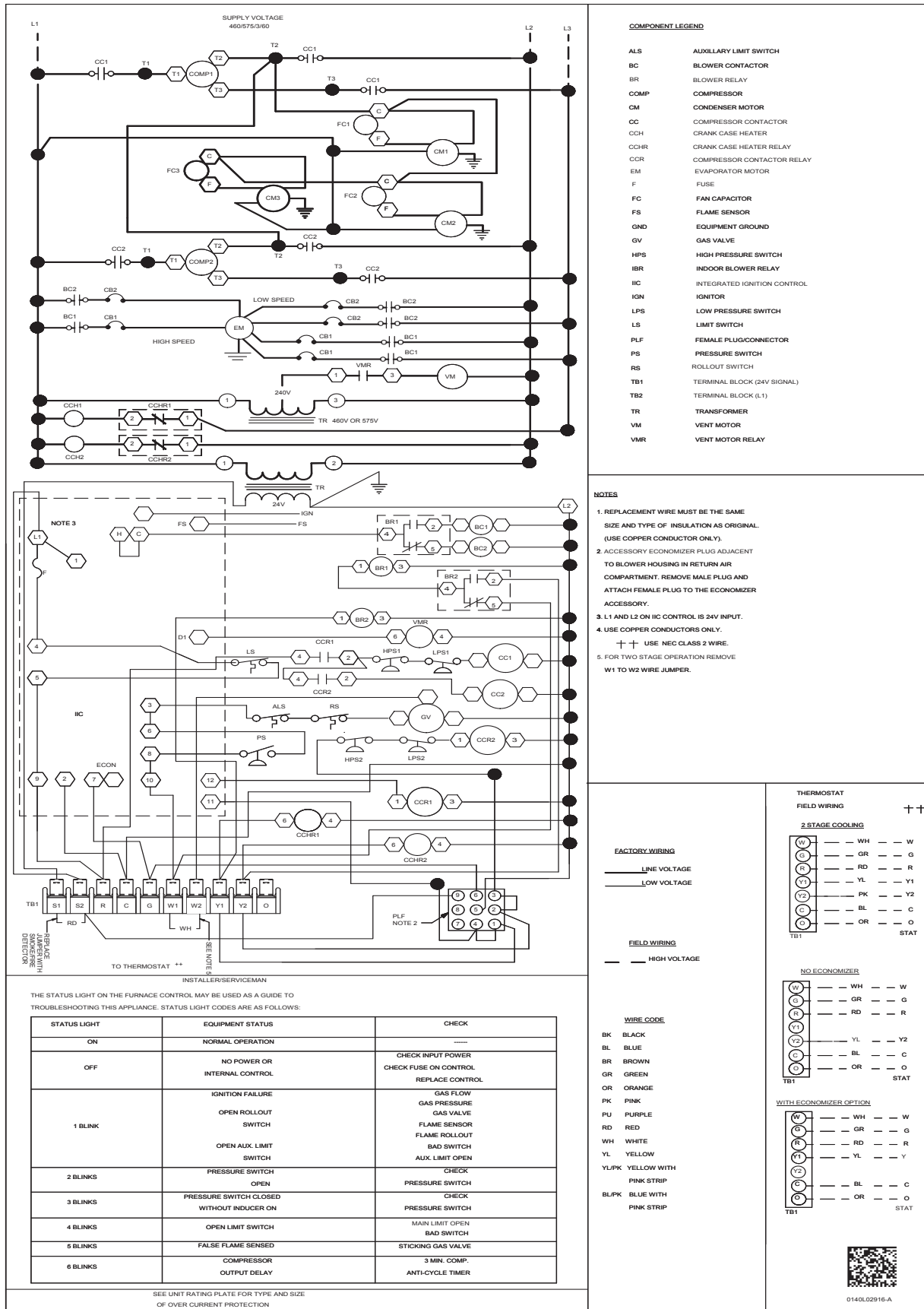

**High Voltage:** Disconnect all power before servicing or installing this unit. Multiple power sources may be present. Failure to do so may cause property damage, personal injury, or death.



Wiring is subject to change. Always refer to the wiring diagram or the unit for the most up-to-date wiring.



0140L02916-A

## ACCESSORIES

FILED-INSTALLED ITEM #	DESCRIPTION	FITS MODEL SIZES	FIELD- INSTALLED	FACTORY- INSTALLED
14CURB180240	14" Roof Curb	15-20 tons	√	
D25FD180240	25% Manual Fresh Air Damper	15-20 tons	√	
D25MFD180240	25% Motorized Fresh Air Damper	15-20 tons	√	
DDNBB180240	Burglar Bar Sleeves with Supply and Return	All Models	√	
CDK180	Concentric Duct Kit	15 tons	√	
CDK240	Concentric Duct Kit	20 tons	√	
	Convenience Outlet: Powered	All Models		√
	Convenience Outlet: Non Powered	All Models		√
	Disconnect Switch (non-fused)	All Models		√
DDNECNJ180240	Downflow Economizer	15-20 tons	√	√
HAKT36300	High-Altitude Kit	All Models	√	
HSKT180G <sup>1</sup>	High-Static Kit (230/460v)	15 tons	√	
HSKT180G-7 <sup>1</sup>	High-Static Kit (575v)	15 tons	√	
HSKT240 <sup>1</sup>	High-Static Kit (230/460v)	20 tons	√	
HSKT240-7 <sup>1</sup>	High-Static Kit (575v)	20 tons	√	
HZCURB180240ED	Horizontal Discharge Curb — End Discharge	15-20 tons	√	
HZCURB180240SDN	Horizontal Discharge Curb — Side Discharge; duct openings on non-service side	15-20 tons	√	
HZCURB180240SDS	Horizontal Discharge Curb — Side Discharge; duct openings on service side	15-20 tons	√	
GHRC-1	Hurricane Restraint Clips	All Models	√	
LAKT03	Low-Ambient Kit	15-20 tons	√	√
LPKT180240	LP Conversion Kit	15-20 tons	√	√
DPE1802402	Power Exhaust (208/230v)	15-20 tons	√	
DPE1802404	Power Exhaust (460v)	15-20 tons	√	
	Smoke Detector	All Models		√

<sup>1</sup> HSKT High-static kits are for use with standard single-speed belt-drive units only.