



Date:

Specification Sheet for Daikin Small Cabinet 3 to 6 Ton
Motorized Fresh Air Damper

Part Number:
Daikin PN: 0270L01165
MicroMetl PN: OA2-DKN12CA-W00S

Submitted To:

Job:

Notes:

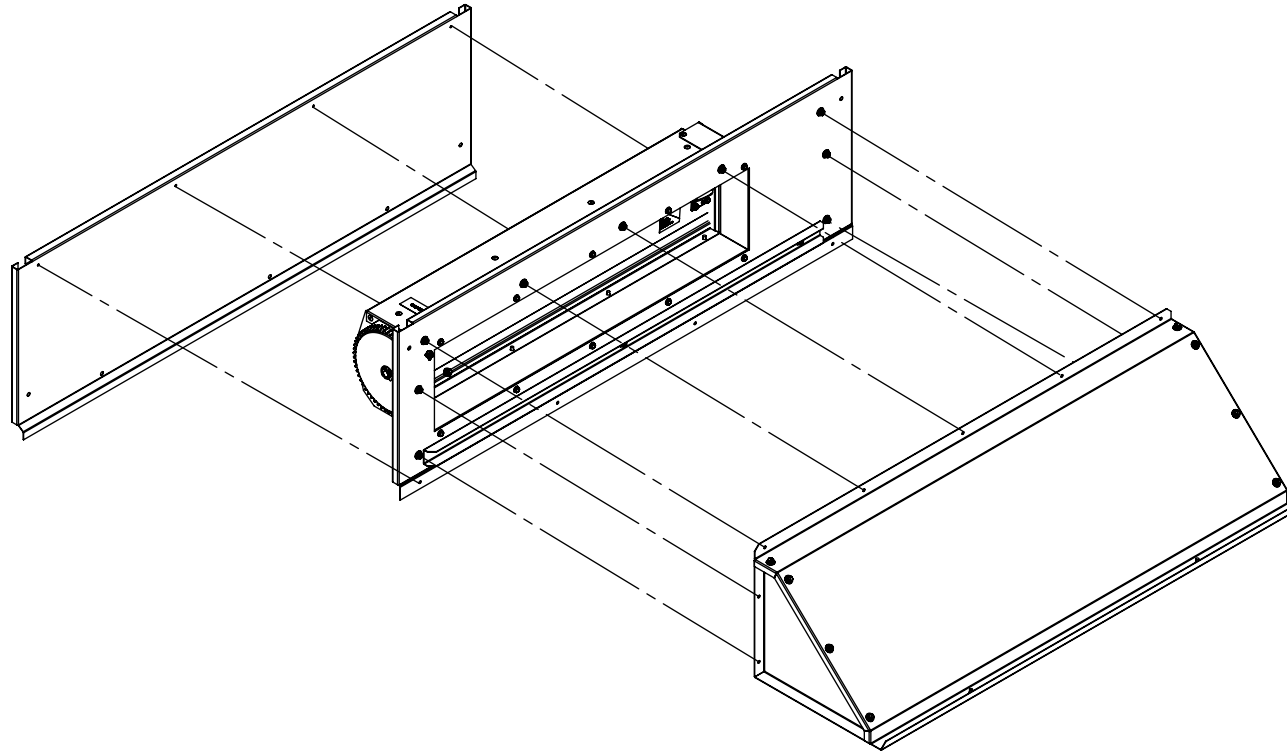

Notes:

1. Panel and hood are painted to match the unit.
2. 2 position actuator provided. Actuator open position is adjustable.
3. Kit can be used in horizontal or vertical application.
4. Panel is insulated with 1" - 1.5 lb. density insulation.

Product Operating Weight:
40 Lbs

The information contained in this drawing is the sole property of MicroMetl Corporation. Any reproduction in part or whole without the written permission of MicroMetl Corporation is prohibited.