



## Features

- Suitable for residential Furnace installations
- Dealer Programmable LCD
- Annual audible and visual service notification
- 16" Twin-tube high UVC lamps
- 360° Parabolic Reflector directs & enhances UVC output
- Soft start electronics with variable voltage protection
- 120V electrical power supply
- Built-in UV "Smart Light" Photocell for lamp operation
- Tandem module outlets for multi-unit installation
- Snap-in/out components for easy installation & servicing
- Compact design

## PREMIUM PLUS WITH LCD TWIN-TUBE LAMP UVC COIL PURIFIER For Furnace Installations



### NOTE:

All LCD models require temperature-controlled environment. The LCD units are not suitable for hot ambient installations. It is recommended that all units are installed at least 4 feet from heat exchangers.

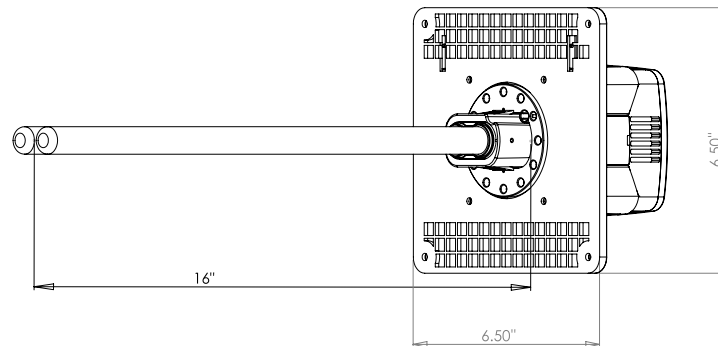

### Specifications

CONSTANT POWER	ELECTRICAL DRAW	HOURS	LAMP TYPE	PARABOLIC REFLECTOR
120V	0.35A	9000	Twin Tube High UVC	Yes

### Service Part Numbers

MODEL	REPLACEMENT LAMP	POWER CORD	BASE	CLIP ASSEMBLY
UC36DL16-DV	UCP-36D16-DV	UCP-DVCORD	UCP-DVBASE	UCP-DVCLIP

5 YEAR PARTS  
/ 1 YEAR LAMP  
LIMITED  
WARRANTY\*

\*Complete warranty details available from your local dealer or at [www.cleancomfort.com](http://www.cleancomfort.com)

