



Description

Dew points and relative humidity (RH) affect the way your body senses heat. Higher humidity levels cause the air to feel much hotter than the actual temperature. When maintained properly, you can run your cooling equipment less because dehumidified air feels cooler.

Ideal humidity is defined by industry experts* as being between 40-60% on an average annual basis. When indoor humidity exceeds 60%, the home is more susceptible to mold and mildew growth. DV120 safeguards against excessive humidity in the home year-round.

*American Society of Heating, Refrigerating, and Air Conditioning Engineers (ASHRAE).

Features and Benefits

- Removes up to 120 pints of water per day from the indoor air.
- Provides Ventilation to the indoor space.
- Electrocoating reduces coil corrosion and helps prevent refrigerant leaks.
- Built-in transformer circuit breaker.
- 6-Year Parts Limited Warranty. Complete warranty details available from your local dealer or at www.cleancomfort.com.

Dehumidifier

Model: DV120



WARNING

Only personnel that have been trained to install, adjust, service or repair (hereinafter, "service") the equipment specified in this manual should service the equipment. The manufacturer and seller will not be responsible for any injury or property damage arising from improper service or service procedures. If you service this unit, you assume responsibility for any injury or property damage which may result. In addition, in jurisdictions that require one or more licenses to service the equipment specified in this manual, only licensed personnel should service the equipment. Improper installation, adjustment, servicing or repair of the equipment specified in this manual, or attempting to install, adjust, service or repair the equipment specified in this manual without proper training may result in product damage, property damage, personal injury or death.

Specifications

Install DV120 according to National Electric Codes.

Dry-Bulb Temp	Intake Humidity	Capacity (Pints/Day)
80°F (26.7°C)	60% RH	120
70°F (21.1°C)	60% RH	88
60°F (15.6°C)	60% RH	63

Home Size (square ft) @ 8 ft ceiling	Dehumidifier Capacity Required to Maintain Desired Indoor RH*		
	60% RH Indoor (pints/day)	50% RH Indoor (pints/day)	40% RH Indoor (pints/day)
2080 (193.2)	49–54	55–58	71–78
2600 (241.5)	61–68	65–72	90–97
3120 (289.9)	75–82	79–86	95–110

* Based on extreme climates where outdoor humidity is 70-90% RH. For less extreme climates, larger homes can be adequately served with less capacity. Actual requirements may vary.

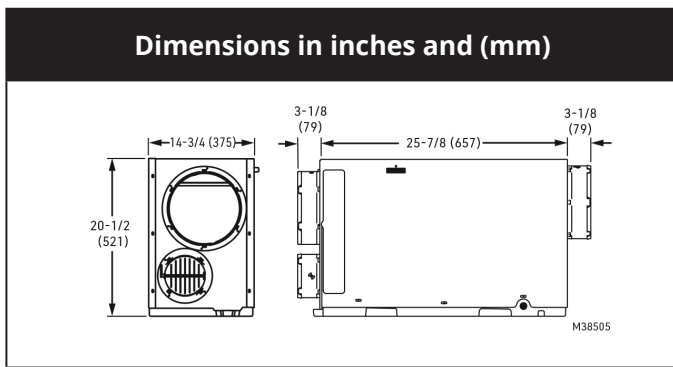

Airflow versus external static pressure (0–1 in. [0 - 25.4 mm] water pressure) with collars attached	
0 in. (0 mm)	400 CFM
0.2 in. (5 mm)	345 CFM
0.4 in. (10 mm)	295 CFM
0.6 in. (15.2 mm)	250 CFM

Product weight: 95lb (43 Kg)

Shipping weight: 104lb (47 Kg)

Shipping dimensions: 26" H × 19.3" W × 35.8" L

Media Filter: MERV 11, 14" H × 17.5" W × 1.75" L

Drain connection: 3/4" threaded female NPT connection

Duct connections: 10" round inlet and outlet. 6" supply inlet. ABS plastic, compatible for connection to rigid or flexible ducting with sheet metal screws and/or tape.

Cabinet: 20 gauge galvanized steel powder-coat painted

Insulation: R value 1

Compressor: Rotary-style, 9.4 kBTU

Refrigerant: R-410A, 30 oz.

Operating Temp Range (outside cabinet): 34°F to 135°F (1.1°C to 57.2°C)

Operating Humidity Range: 0-99% RH

Input ratings

- Electrical input voltage: 120 VAC, 60 Hz nominal
- Input current: 7.3 A

Output ratings

- Power transformer to R/C terminals: 24 VAC, 0.85 A
- Energy Performance: 2.9 liters (6.1 pints) per kilowatt hour (KWH)

Goodman Manufacturing Company, L.P., reserves the right to discontinue, or change at any time, specifications or designs without notice or without incurring obligations. ©2020 Goodman Manufacturing Company, L.P. • Houston, Texas • Printed in the USA.