



### Quality and Reliability

Proven design using electrode technology perfected by Dri-Steem® a subsidiary of Research Products.

### High Capacity

One unit can provide between 11.5 and 34.6 gallons per day.

### Easy to Install

Remote or duct mount with no additional accessories.

### Easy to Maintain

No cleaning or scrubbing, simply remove canister and replace.

### Dispersion and Absorption

Steam dispersion technology ensures proper dispersion into the air, preventing condensation in duct.

### No Accessories Required

Control, dispersion tube, steam hose and drain tube included in the box.

### Model 850 Fan Pack



**Weight: 10 lbs**

• 24 VAC • 60 Hz • 0.75 Amps

- The Model 850 Fan Pack marries with the Aprilaire Model 800 Steam Humidifier to provide comfortable humidity levels in homes without duct work.
- Quiet operation makes the Model 850 Fan Pack practically unnoticeable.
- Designed to blend into a home's environment.
- Easy install – Recessed into a wall and connects directly to the Model 800 Steam Humidifier.

| Voltage | Current draw |     | Maximum steam capacity |
|---------|--------------|-----|------------------------|
|         | Amps         | Kw  | gal/day                |
| 120V    | 11.5         | 1.4 | 11.5                   |
|         | 16.0         | 1.9 | 16.0                   |
| 208V    | 11.5         | 2.4 | 20.5                   |
|         | 16.0         | 3.3 | 30.0                   |
| 240V    | 11.5         | 2.8 | 23.3                   |
|         | 16.0         | 3.8 | 34.6                   |

- Water Hardness – 3 to 36 grain per gallon, water filtration not necessary
- Water Conductivity – 125-1250 micro Siemens per centimeter (µS/cm)
- Supply water pressure must be between 25 psi and 120 psi
- Drain water flushed and tempered with cold fresh inlet water
- Electrical draw 11.5 amps or 16 amps
- Canister replacement once per humidifier season under normal conditions. Canister life will depend on water quality and run time. Unit will automatically notify when canister must be replaced.
- Operating Weight - up to 27 lbs.

# MODEL 800 STEAM HUMIDIFIER

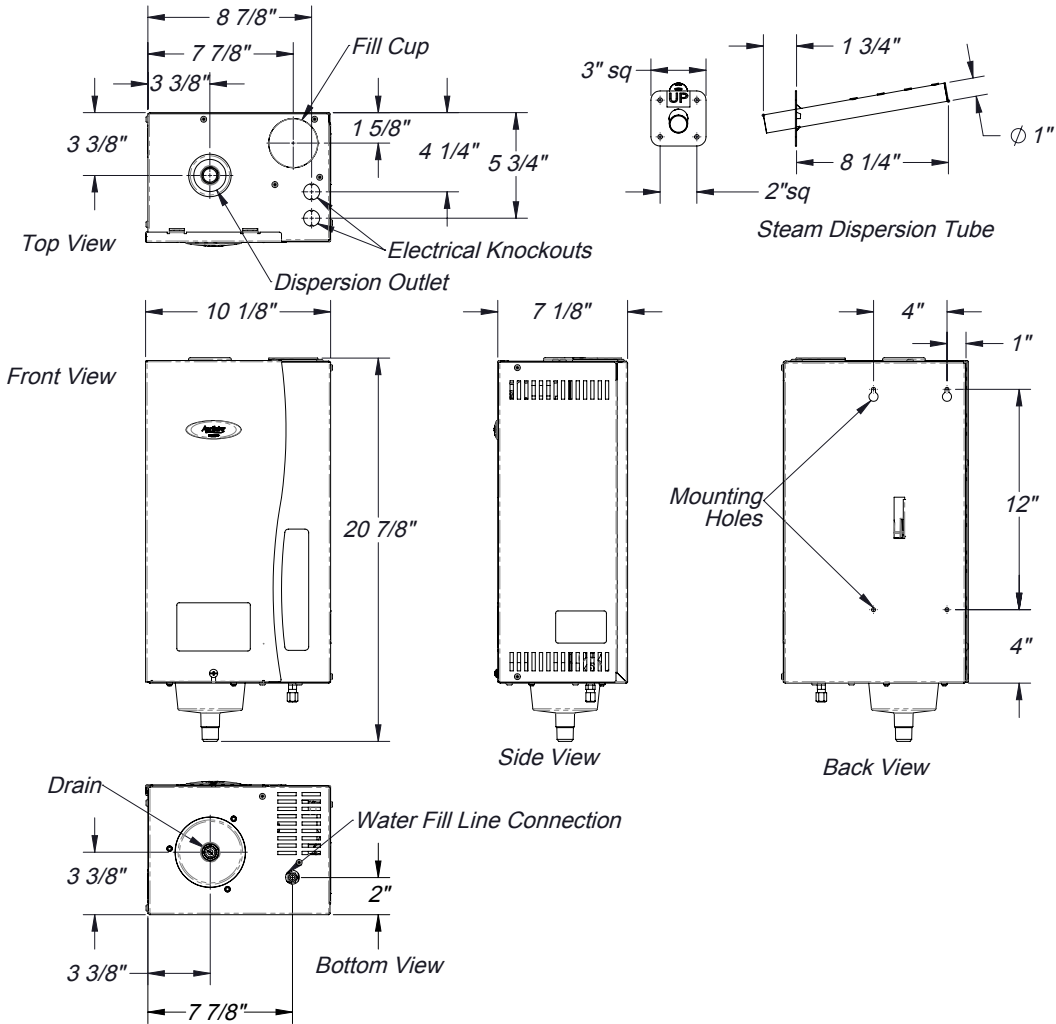

# MODEL 850 FAN PACK

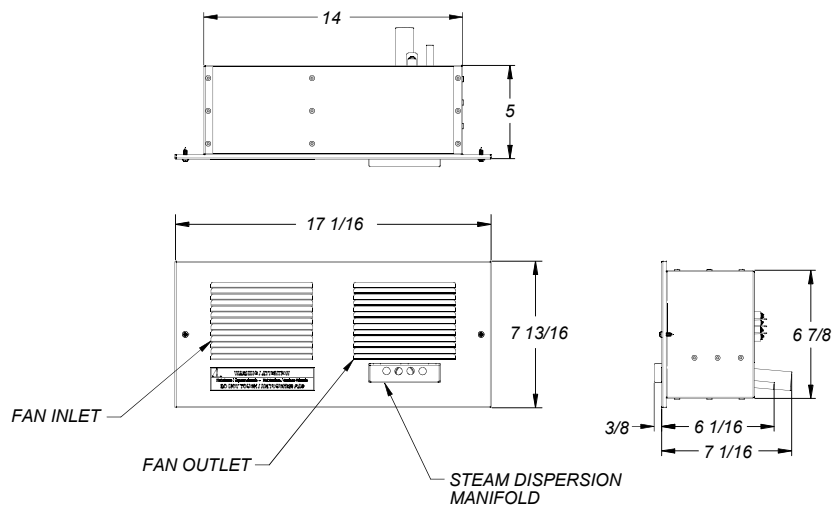

RESEARCH PRODUCTS RESERVES THE RIGHT TO CHANGE SPECIFICATIONS WITHOUT NOTICE.