

# Service Instructions

**ANX, SSX, ASX, GSX, DSX, ASXC, DSXC  
Condensing Units,  
ANZ, SSZ, ASZ, GSZ, DSZ, ASZC, DSZC, VSX, VSZ Split  
System Heat Pumps  
with R-410A Refrigerant  
Blowers, Coils, & Accessories**

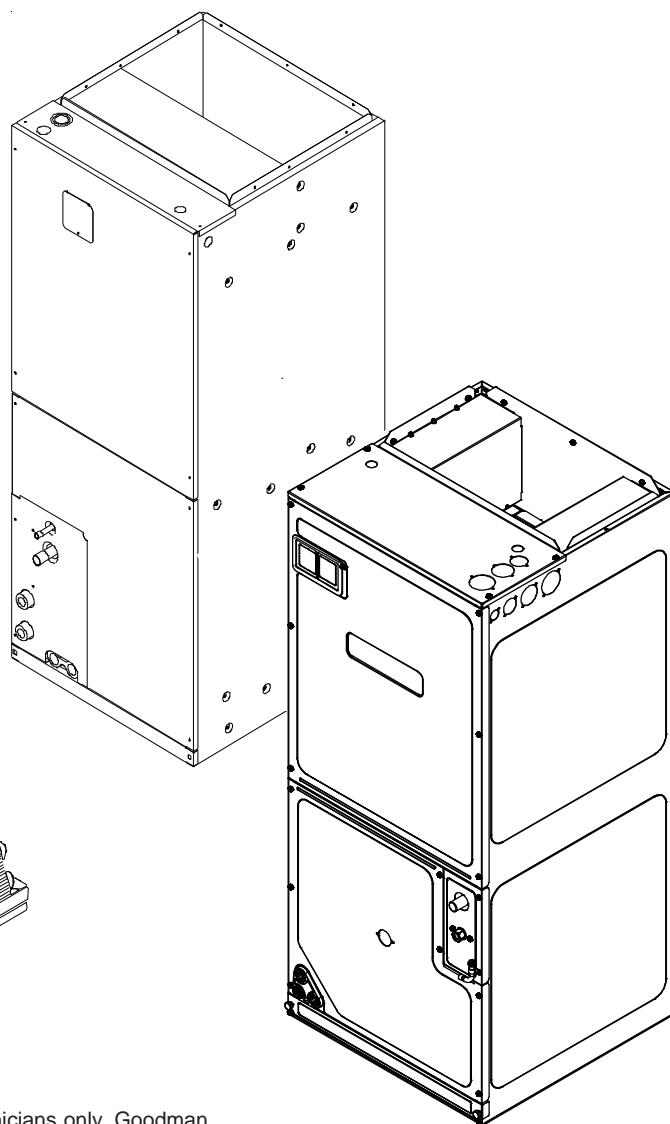
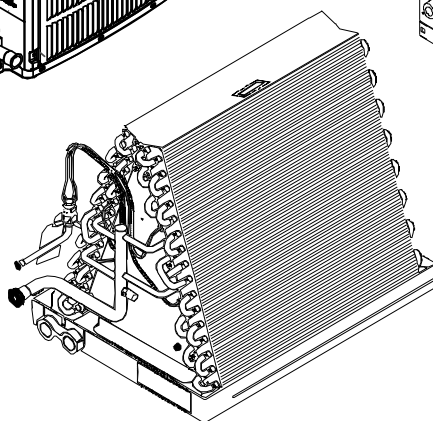
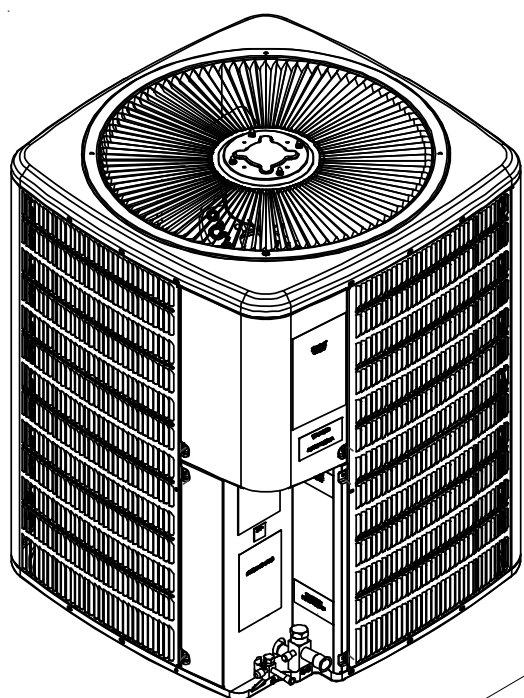

This manual is to be used by qualified, professionally trained HVAC technicians only. Goodman does not assume any responsibility for property damage or personal injury due to improper service procedures or services performed by an unqualified person.

RS6200006r62  
February 2015

# IMPORTANT INFORMATION

|   |         |                                   |           |
|---|---------|-----------------------------------|-----------|
| IMPORTANT INFORMATION .....                   | 2 - 3   | SYSTEM OPERATION .....            | 63 - 67   |
| PRODUCT IDENTIFICATION .....                  | 4 - 36  | TROUBLESHOOTING CHART .....       | 68        |
| PRODUCT IDENTIFICATION (LIGHT COMMERCIAL) ... | 35 - 36 | SERVICE TABLE OF CONTENTS .....   | 69        |
| ACCESSORIES (LIGHT COMMERCIAL) .....          | 37      | SERVICING .....                   | 70 - 162  |
| ACCESSORIES .....                             | 38 - 59 | ACCESSORIES WIRING DIAGRAMS ..... | 163 - 173 |
| PRODUCT DESIGN .....                          | 60 - 62 | WIRING DIAGRAMS.....              | 174-288   |

Pride and workmanship go into every product to provide our customers with quality products. It is possible, however, that during its lifetime a product may require service. Products should be serviced only by a qualified service technician who is familiar with the safety procedures required in the repair and who is equipped with the proper tools, parts, testing instruments and the appropriate service manual. **REVIEW ALL SERVICE INFORMATION IN THE APPROPRIATE SERVICE MANUAL BEFORE BEGINNING REPAIRS.**

## IMPORTANT NOTICES FOR CONSUMERS AND SERVICERS RECOGNIZE SAFETY SYMBOLS, WORDS AND LABELS

### WARNING

**THIS UNIT SHOULD NOT BE CONNECTED TO, OR USED IN CONJUNCTION WITH, ANY DEVICES THAT ARE NOT DESIGN CERTIFIED FOR USE WITH THIS UNIT OR HAVE NOT BEEN TESTED AND APPROVED BY GOODMAN. SERIOUS PROPERTY DAMAGE OR PERSONAL INJURY, REDUCED UNIT PERFORMANCE AND/OR HAZARDOUS CONDITIONS MAY RESULT FROM THE USE OF DEVICES THAT HAVE NOT BEEN APPROVED OR CERTIFIED BY GOODMAN.**

### WARNING

**INSTALLATION AND REPAIR OF THIS UNIT SHOULD BE PERFORMED ONLY BY INDIVIDUALS MEETING THE REQUIREMENTS OF AN ENTRY LEVEL TECHNICIAN, AT A MINIMUM, AS SPECIFIED BY THE AIR-CONDITIONING, HEATING, AND REFRIGERATION INSTITUTE (AHRI). ATTEMPTING TO INSTALL OR REPAIR THIS UNIT WITHOUT SUCH BACKGROUND MAY RESULT IN PRODUCT DAMAGE, PERSONAL INJURY, OR DEATH.**

### WARNING

**TO PREVENT THE RISK OF PROPERTY DAMAGE, PERSONAL INJURY, OR DEATH, DO NOT STORE COMBUSTIBLE MATERIALS OR USE GASOLINE OR OTHER FLAMMABLE LIQUIDS OR VAPORS IN THE VICINITY OF THIS APPLIANCE.**

### WARNING

**GOODMAN WILL NOT BE RESPONSIBLE FOR ANY INJURY OR PROPERTY DAMAGE ARISING FROM IMPROPER SERVICE OR SERVICE PROCEDURES. IF YOU INSTALL OR PERFORM SERVICE ON THIS UNIT, YOU ASSUME RESPONSIBILITY FOR ANY PERSONAL INJURY OR PROPERTY DAMAGE WHICH MAY RESULT. MANY JURISDICTIONS REQUIRE A LICENSE TO INSTALL OR SERVICE HEATING AND AIR CONDITIONING EQUIPMENT.**

### WARNING

**HIGH VOLTAGE  
DISCONNECT ALL POWER BEFORE SERVICING OR INSTALLING THIS UNIT. MULTIPLE POWER SOURCES MAY BE PRESENT. FAILURE TO DO SO MAY CAUSE PROPERTY DAMAGE, PERSONAL INJURY OR DEATH.**



To locate an authorized servicer, please consult your telephone book or the dealer from whom you purchased this product. For further assistance, please contact:

### CONSUMER INFORMATION LINE

#### GOODMAN® BRAND PRODUCTS

TOLL FREE

1-877-254-4729 (U.S. only)

email us at: [customerservice@goodmanmfg.com](mailto:customerservice@goodmanmfg.com)

fax us at: (713) 856-1821

(Not a technical assistance line for dealers.)

#### AMANA® BRAND PRODUCTS

TOLL FREE

1-877-254-4729 (U.S. only)

email us at: [customerservice@goodmanmfg.com](mailto:customerservice@goodmanmfg.com)

fax us at: (713) 856-1821

(Not a technical assistance line for dealers.)

Outside the U.S., call 1-713-861-2500.

(Not a technical assistance line for dealers.) Your telephone company will bill you for the call.

# IMPORTANT INFORMATION

## SAFE REFRIGERANT HANDLING

While these items will not cover every conceivable situation, they should serve as a useful guide.

### WARNING

REFRIGERANTS ARE HEAVIER THAN AIR. THEY CAN "PUSH OUT" THE OXYGEN IN YOUR LUNGS OR IN ANY ENCLOSED SPACE. TO AVOID POSSIBLE DIFFICULTY IN BREATHING OR DEATH:

- NEVER PURGE REFRIGERANT INTO AN ENCLOSED ROOM OR SPACE. BY LAW, ALL REFRIGERANTS MUST BE RECLAIMED.
- IF AN INDOOR LEAK IS SUSPECTED, THOROUGHLY VENTILATE THE AREA BEFORE BEGINNING WORK.
- LIQUID REFRIGERANT CAN BE VERY COLD. TO AVOID POSSIBLE FROST-BITE OR BLINDNESS, AVOID CONTACT WITH REFRIGERANT AND WEAR GLOVES AND GOGGLES. IF LIQUID REFRIGERANT DOES CONTACT YOUR SKIN OR EYES, SEEK MEDICAL HELP IMMEDIATELY.
- ALWAYS FOLLOW EPA REGULATIONS. NEVER BURN REFRIGERANT, AS POISONOUS GAS WILL BE PRODUCED.

### WARNING

THE UNITED STATES ENVIRONMENTAL PROTECTION AGENCY ("EPA") HAS ISSUED VARIOUS REGULATIONS REGARDING THE INTRODUCTION AND DISPOSAL OF REFRIGERANTS INTRODUCED INTO THIS UNIT. FAILURE TO FOLLOW THESE REGULATIONS MAY HARM THE ENVIRONMENT AND CAN LEAD TO THE IMPOSITION OF SUBSTANTIAL FINES. THESE REGULATIONS MAY VARY BY JURISDICTION. SHOULD QUESTIONS ARISE, CONTACT YOUR LOCAL EPA OFFICE.

### WARNING

SYSTEM CONTAMINANTS, IMPROPER SERVICE PROCEDURE AND/OR PHYSICAL ABUSE AFFECTING HERMETIC COMPRESSOR ELECTRICAL TERMINALS MAY CAUSE DANGEROUS SYSTEM VENTING.

The successful development of hermetically sealed refrigeration compressors has completely sealed the compressor's moving parts and electric motor inside a common housing, minimizing refrigerant leaks and the hazards sometimes associated with moving belts, pulleys or couplings.

Fundamental to the design of hermetic compressors is a method whereby electrical current is transmitted to the compressor motor through terminal conductors which pass through the compressor housing wall. These terminals are sealed in a dielectric material which insulates them from the housing and maintains the pressure tight integrity of the hermetic compressor. The terminals and their dielectric embedment are strongly constructed, but are vulnerable to careless compressor installation or maintenance procedures and equally vulnerable to internal electrical short circuits caused by excessive system contaminants.

### WARNING

TO AVOID POSSIBLE EXPLOSION:

- NEVER APPLY FLAME OR STEAM TO A REFRIGERANT CYLINDER. IF YOU MUST HEAT A CYLINDER FOR FASTER CHARGING, PARTIALLY IMMERSE IT IN WARM WATER.
- NEVER FILL A CYLINDER MORE THAN 80% FULL OF LIQUID REFRIGERANT.
- NEVER ADD ANYTHING OTHER THAN R-22 TO AN R-22 CYLINDER OR R-410A TO AN R-410A CYLINDER. THE SERVICE EQUIPMENT USED MUST BE LISTED OR CERTIFIED FOR THE TYPE OF REFRIGERANT USED.
- STORE CYLINDERS IN A COOL, DRY PLACE. NEVER USE A CYLINDER AS A PLATFORM OR A ROLLER.

### WARNING

TO AVOID POSSIBLE EXPLOSION, USE ONLY RETURNABLE (NOT DISPOSABLE) SERVICE CYLINDERS WHEN REMOVING REFRIGERANT FROM A SYSTEM.

- ENSURE THE CYLINDER IS FREE OF DAMAGE WHICH COULD LEAD TO A LEAK OR EXPLOSION.
- ENSURE THE HYDROSTATIC TEST DATE DOES NOT EXCEED 5 YEARS.
- ENSURE THE PRESSURE RATING MEETS OR EXCEEDS 400 LBS.

WHEN IN DOUBT, DO NOT USE CYLINDER.

### WARNING

TO AVOID POSSIBLE INJURY, EXPLOSION OR DEATH, PRACTICE SAFE HANDLING OF REFRIGERANTS.

In either of these instances, an electrical short between the terminal and the compressor housing may result in the loss of integrity between the terminal and its dielectric embedment. This loss may cause the terminals to be expelled, thereby venting the vaporous and liquid contents of the compressor housing and system.

A venting compressor terminal normally presents no danger to anyone, providing the terminal protective cover is properly in place.

If, however, the terminal protective cover is not properly in place, a venting terminal may discharge a combination of

- hot lubricating oil and refrigerant
- flammable mixture (if system is contaminated with air)

in a stream of spray which may be dangerous to anyone in the vicinity. Death or serious bodily injury could occur.

Under no circumstances is a hermetic compressor to be electrically energized and/or operated without having the terminal protective cover properly in place.

See Service Section S-17 for proper servicing.

# PRODUCT IDENTIFICATION

| Split System Heat Pumps R410A   |  |
|---|--|
| Model #   | Description  |
| ASZ130**1AA   | Amana® Brand <u>S</u> plit <u>Z</u> R410A heat pump 13 Seer heat pump units. Initial release of Amana® Brand 13 SEER Heat Pump R410A.  |
| ASZ130**1AB   | Amana® Brand <u>S</u> plit <u>Z</u> R410A heat pump 13 Seer heat pump units. Introduces new revisions with improved circuiting for effective defrost.  |
| ASZ130[18, 36-60]1AB<br>ASZ130[24-30]1AC  | Amana® Brand <u>S</u> plit <u>Z</u> R410A heat pump 13 Seer heat pump units. Introduces models containing crankcase heater, CCH switch and upgraded defrost control.   |
| ASZ130[18, 36-60]1AC<br>ASZ130[24-30]1AD  | Amana® Brand <u>S</u> plit <u>Z</u> R410A heat pump 13 Seer heat pump units. Relocation of low pressure switch from liquid line to suction line as a compressor safeguard to prevent low pressure from entering. |
| ASZ130[18, 36-60]1AD<br>ASZ130[24-30]1AE  | Amana® Brand <u>S</u> plit <u>Z</u> R410A heat pump 13 Seer heat pump units. Initial release of models using single speed PSC motors; removal of low ambient temperature switch.                                 |
| ASZ130241BA   | Amana® Brand <u>S</u> plit <u>Z</u> R410A heat pump 13 Seer heat pump units. Release of 2 Ton models, converting from 3/8" to 5mm condenser coils  |
| ASZ130181AF<br>ASZ130[24-30]1AG   | Amana® Brand <u>S</u> plit <u>Z</u> R410A heat pump 13 Seer heat pump units. Current reversing valve change from Dunan to new SanHua reversing valve   |
| ASZ130481AF   | Amana® Brand <u>S</u> plit <u>Z</u> R410A heat pump 13 Seer heat pump units. Current Ranco reversing valve 0151M00020 replaced by SanHua 0151R00070 reversing valve  |
| ASZ140**1AA   | Amana® Brand <u>S</u> plit <u>Z</u> R410A heat pump 14 Seer heat pump units. Initial release of Amana® Brand 14 SEER Heat Pump R410A.  |
| ASZ140**1AB   | Amana® Brand <u>S</u> plit <u>Z</u> R410A heat pump 14 Seer heat pump units. Introduces new revisions have screw locations moved in the top panel, base pans, louvers, and control box covers.                   |
| ASZ140**1AC   | Amana® Brand <u>S</u> plit <u>Z</u> R410A heat pump 14 Seer heat pump units. New revisions have horizontal style louvers.  |
| ASZ140[18, 42-48]1AD<br>ASZ140[24-36, 60]1AE  | Amana® Brand <u>S</u> plit <u>Z</u> R410A heat pump 14 Seer heat pump units. Adds new steel muffler, and suction tubes w/shock loop.   |
| ASZ140361AF<br>ASZ140421AD<br>ASZ140[48-60]1AE  | Amana® Brand <u>S</u> plit <u>Z</u> R410A heat pump 14 Seer heat pump units. New revisions replace TXV & compensator with flowrator & accumulator.   |
| ASZ140[18, 30,36]1AF<br>ASZ140241AG<br>ASZ14[42, 48, 60]1AE                                 | Amana® Brand <u>S</u> plit <u>Z</u> R410A heat pump 14 Seer heat pump units. New revisions will have Sanhua (RANCO) reversing valves.  |
| ASZ140241AF   | Amana® Brand <u>S</u> plit <u>Z</u> R410A heat pump 14 Seer heat pump units. AF revision has the smaller B1227315 reversing valve.   |
| ASZ140[18,30,36]1AG<br>ASZ140241AH<br>ASZC160[42,48,60]1AF                                  | Amana® brand <u>S</u> plit <u>Z</u> Communicating heat pump, 14 Seer R410A heat pump units. Introduces Amana 14 SEER heat pumps with accumulators, crankcase heaters, and upgraded defrost control.              |
| ASZ140361BA   | Amana® Brand <u>S</u> plit <u>Z</u> R410A heat pump 14 Seer heat pump units. Initial release of Amana® Brand 14 SEER Heat Pump R410A, with reduced chassis size from large to medium.                            |
| ASZ140[18, 30]1AH<br>ASZ140241AJ<br>ASZ140[42-60]1AG  | Amana® Brand <u>S</u> plit <u>Z</u> R410A heat pump 14 Seer heat pump units. Relocation of low pressure switch from liquid line to suction line as a compressor safeguard to prevent low pressure from entering. |
| ASZ140[18, 30]1AJ<br>ASZ140241AK<br>ASZ140[42-60]1AH<br>ASZ140361BB                         | Amana® Brand <u>S</u> plit <u>Z</u> R410A heat pump 14 Seer heat pump units.   |
| ASZ140181AL<br>ASZ140241AM<br>ASZ140301AL<br>ASZ140361BC<br>ASZ140381AB<br>ASZ140[42-60]1AK | Amana® Brand <u>S</u> plit <u>Z</u> R410A heat pump 14 Seer heat pump units. Revision made for design improvement.   |
| ASZ140381AA   | Amana® Brand <u>S</u> plit <u>Z</u> R410A heat pump 14 Seer heat pump units. 35" chassis with 6-channel flowrator and ZP29K5 compressor.   |
| ASZ140[18-30]1BA  | Amana® Brand <u>S</u> plit <u>Z</u> R410A heat pump 14 Seer heat pump units. Updating ratings and agency information.  |

# PRODUCT IDENTIFICATION

| Split System Heat Pumps R410A          |  |
|--|--|
| Model #                                | Description  |
| ASZ160**1AA                            | <u>A</u> mana® Brand <u>S</u> plit <u>Z</u> R410A heat pump 16 Seer heat pump units. Initial release of Amana® Brand 16 SEER Heat Pump R410A.  |
| ASZ160**1AB                            | <u>A</u> mana® Brand <u>S</u> plit <u>Z</u> R410A heat pump 16 Seer heat pump units. Introduces new revisions have screw locations moved in the top panel, base pans, louvers, and control box covers. |
| ASZ160**1AC                            | <u>A</u> mana® Brand <u>S</u> plit <u>Z</u> R410A heat pump 16 Seer heat pump units. New revisions have horizontal style louvers.  |
| ASZ160**1AD                            | <u>A</u> mana® Brand <u>S</u> plit <u>Z</u> R410A heat pump 16 Seer heat pump units. New revisions added Muffler and standardized TXV, Compensator using the ASZ18 Seer weldment.                      |
| ASZ160241AD<br>ASZ160[36-60]AE         | <u>A</u> mana® Brand <u>S</u> plit <u>Z</u> R410A heat pump 16 Seer heat pump units. Adds new steel muffler, and suction tubes w/shock loop.   |
| ASZ160[24, 36]1AF<br>ASZ160[48, 60]1AF | <u>A</u> mana® Brand <u>S</u> plit <u>Z</u> R410A heat pump 16 Seer heat pump units. New revisions will have Sanhua (RANCO) reversing valves.  |
| ASZ160[24,36,48,60]1KA                 | <u>A</u> mana® Brand <u>S</u> plit <u>Z</u> R410A heat pump 16 Seer heat pump units.   |
| ASZ180**1AB                            | <u>A</u> mana® Brand <u>S</u> plit <u>Z</u> R410A heat pump 18 Seer heat pump units. Initial release of Amana® Brand 18 SEER Heat Pump R410A.  |
| ASZ180[36, 48, 60]1AC                  | <u>A</u> mana® Brand <u>S</u> plit <u>Z</u> R410A heat pump 18 Seer heat pump units. New revisions will have Sanhua (RANCO) reversing valves.  |

| Split System Heat Pumps R410A |  |
|-------------------------------|--|
| Model #                       | Description  |
| ANZ130[18-60]1AA              | <u>A</u> mana® Brand Split System Base Heat Pump, 13 Seer R-410A units.  |
| ANZ130[18/24/30]1AB           | <u>A</u> mana® Brand Split System Base Heat Pump, 13 Seer R-410A units. Current reversing valve change from Dunan to new SanHua reversing valve                |
| ANZ130481AB                   | <u>A</u> mana® Brand Split System Base Heat Pump, 13 Seer R-410A units. Current Ranco reversing valve 0151M00020 replaced by SanHua 0151R00070 reversing valve |

# PRODUCT IDENTIFICATION

| Split System Heat Pumps R410A            |   |
|--|---|
| Model #                                  | Description   |
| ASZC160**1AA                             | Amana® brand Split Z Communicating heat pump, 16 Seer R410A heat pump units. Introduces Goodman 2-stage 16 SEER heat pumps with R-410A, communicating models.   |
| ASZC160[24, 36]1AB<br>ASZC160[48, 60]1AB | Amana® brand Split Z Communicating heat pump, 16 Seer R410A heat pump units. New revisions will have Sanhua (RANCO) reversing valves.   |
| ASZC160[24-48]1AC<br>ASZC160601BA        | Amana® brand Split Z Communicating heat pump, 16 Seer R410A heat pump units. Introduces Amana 2-stage 16 SEER heat pumps with accumulators and crankcase heaters.   |
| ASZC160[24-36]1AD<br>ASZC160601BB        | Amana® brand Split Z Communicating heat pump, 16 Seer R410A heat pump units. Change motor to Nidec.   |
| ASZC160[24-36]1AE                        | Amana® brand Split Z Communicating heat pump, 16 Seer R410A heat pump units. New revision replaces existing compressor ZPS20K4EPFV230 to ZPS20K5EPFV130 & existing compressor ZPS30K4EPFV230 to ZPS30K5EPFV130. |
| ASZC160481AE<br>ASZX180601BC             | Amana® brand Split Z Communicating heat pump, 18 Seer R410A heat pump units. Introduces Ultratech 2.0®.   |
| ASZC180**1AA                             | Amana® brand Split Z Communicating heat pump, 18 Seer R410A heat pump units. Introduces Goodman 2-stage 16 SEER heat pumps with R-410A, communicating models.   |
| ASZC180[36, 48, 60]1AB                   | Amana® brand Split Z Communicating heat pump, 18 Seer R410A heat pump units. Introduces Amana 2-stage 16 SEER heat pumps with accumulators and crankcase heaters.   |
| ASZC180[36-48]1AC<br>ASZC180601BA        | Amana® brand Split Z Communicating heat pump, 18 Seer R410A heat pump units. New revisions will have Sanhua (RANCO) reversing valves.   |
| ASZC180361AD                             | Amana® brand Split Z Communicating heat pump, 18 Seer R410A heat pump units. New revisions will have Sanhua (RANCO) reversing valves.   |
| ASZC180481AD<br>ASZX180601BB             | Amana® brand Split Z Communicating heat pump, 18 Seer R410A heat pump units. Introduces Ultratech 2.0®.   |

# PRODUCT IDENTIFICATION

| Split System Heat Pumps R410A            |  |
|--|--|
| Model #                                  | Description  |
| DSZ160**1AA                              | <u>D</u> eluxe <u>S</u> plit <u>Z</u> Heat Pump 16 Seer heat pump units. Introduces Goodman 2-stage 16 SEER heat pumps with R-410A.  |
| DSZ160241AC<br>DSZ16036, 48, 60]1AB      | <u>D</u> eluxe <u>S</u> plit <u>Z</u> Heat Pump 16 Seer heat pump units. Goodman 2-stage 16 SEER heat pumps with R-410A. New revisions will have Sanhua (RANCO) reversing valves.  |
| DSZ180**1AA                              | <u>D</u> eluxe <u>S</u> plit <u>Z</u> Heat Pump 18 Seer heat pump units. Introduces Goodman 2-stage 18 SEER heat pumps with R-410A.  |
| DSZ180[36, 48, 60]1AB                    | <u>D</u> eluxe <u>S</u> plit <u>Z</u> Heat Pump 18 Seer heat pump units. Goodman 2-stage 18 SEER heat pumps with R-410A. New revisions will have Sanhua (RANCO) reversing valves.  |
| DSZC16**1AA                              | <u>D</u> eluxe <u>S</u> plit <u>Z</u> <u>C</u> ommunicating heat pump, 16 Seer R410A heat pump units. Introduces Goodman 2-stage 16 SEER heat pumps with R-410A, communicating models.   |
| DSZC160[24, 36]1AB<br>DSZC160[48, 60]1AB | <u>D</u> eluxe <u>S</u> plit <u>Z</u> <u>C</u> ommunicating heat pump, 16 Seer R410A heat pump units. Goodman 2-stage 16 SEER heat pumps with R-410A, communicating models. New revisions will have Sanhua (RANCO) reversing valves.       |
| DSZC 160[24-48]1AC<br>DSZC160601BA       | <u>D</u> eluxe <u>S</u> plit <u>Z</u> <u>C</u> ommunicating heat pump, 16 Seer R410A heat pump units. Introduces Goodman 2-stage 16 SEER heat pumps with accumulators and crankcase heaters.   |
| DSZC 160[24-48]1AD<br>DSZC160601BB       | <u>D</u> eluxe <u>S</u> plit <u>Z</u> <u>C</u> ommunicating heat pump, 16 Seer R410A heat pump units. Introduces Ultratech 2.0@ compressor changes.  |
| DSZC160[24-36]1AE                        | <u>D</u> eluxe <u>S</u> plit <u>Z</u> <u>C</u> ommunicating heat pump, 16 Seer R410A heat pump units. New revision replaces existing compressor ZPS20K4EPFV230 to ZPS20K5EPF V130 & existing compressor ZPS30K4EPF V230 to ZPS30K5EPFV130. |
| DSZC160481AE<br>DSZC160601BC             | <u>D</u> eluxe <u>S</u> plit <u>Z</u> <u>C</u> ommunicating heat pump, 16 Seer R410A heat pump units. Introduces Ultratech 2.0@ compressor changes.  |
| DSZC18**1AA                              | <u>D</u> eluxe <u>S</u> plit <u>Z</u> <u>C</u> ommunicating heat pump, 18 Seer R410A heat pump units. Introduces Goodman 2-stage 18 SEER heat pumps with R-410A, communicating models.   |
| DSZC180[36, 48, 60]1AB                   | <u>D</u> eluxe <u>S</u> plit <u>Z</u> <u>C</u> ommunicating heat pump, 18 Seer R410A heat pump units. Goodman 2-stage 18 SEER heat pumps with R-410A, communicating models. New revisions will have Sanhua (RANCO) reversing valves.       |
| DSZC 180[36-48]1AC<br>DSZC180601BA       | <u>D</u> eluxe <u>S</u> plit <u>Z</u> <u>C</u> ommunicating heat pump, 18 Seer R410A heat pump units. Introduces Goodman 2-stage 18 SEER heat pumps with accumulators and crankcase heaters.   |
| DSZC180361AD                             | <u>D</u> eluxe <u>S</u> plit <u>Z</u> <u>C</u> ommunicating heat pump, 18 Seer R410A heat pump units. New revision replaces existing compressor ZPS20K4EPFV230 to ZPS20K5EPF V130 & existing compressor ZPS30K4EPF V230 to ZPS30K5EPFV130. |
| DSZC 160[24-48]1AD<br>DSZC160601BB       | <u>D</u> eluxe <u>S</u> plit <u>Z</u> <u>C</u> ommunicating heat pump, 16 Seer R410A heat pump units. Introduces Ultratech 2.0@ compressor changes.  |

# PRODUCT IDENTIFICATION

| Split System Heat Pumps R410A  |   |
|--|---|
| Model #  | Description   |
| GSZ13**1AA   | Goodman <u>S</u> plit <u>Z</u> R410A Heat Pump 13 Seer heat pump units. Initial release with Regal Beloit motor.  |
| GSZ13**1AB<br>GSZ13**3AA<br>GSZ13**4AA   | Goodman <u>S</u> plit <u>Z</u> R410A Heat Pump 13 Seer heat pump units. Initial release with Broad Ocean motor.   |
| GSZ130[24 & 30]1AC   | Goodman <u>S</u> plit <u>Z</u> R410A Heat Pump 13 Seer heat pump units. Introduces new revisions with improved circuiting for effective defrost.  |
| GSZ130[24 & 36]1BA   | Goodman <u>S</u> plit <u>Z</u> R410A Heat Pump 13 Seer heat pump units. Initial release of models with 5mm Smart Coil™.   |
| GSZ130241CA  | Goodman <u>S</u> plit <u>Z</u> R410A Heat Pump 13 Seer heat pump units. Release of 2 Ton models with a compressor change from ZP21K5EPFV130 to ZP20K5EPFV130.   |
| GSZ130241CB  | Goodman <u>S</u> plit <u>Z</u> R410A Heat Pump 13 Seer heat pump units. 2 Ton models changing from the current four piece louver assembly, to a two piece louver plus a corner post on Goodman and value series 26" and 29" chassis.                                  |
| GSZ130[18, 42-60]1AC<br>GSZ130301AD<br>GSZ130361BB                                       | Goodman <u>S</u> plit <u>Z</u> R410A Heat Pump 13 Seer heat pump units. Introduces models containing crankcase heater, CCH switch and upgraded defrost control.   |
| GSZ130[18,42,48,60]1AD<br>GSZ130301AE<br>GSZ130[36,48,60]{3,4}AB<br>GSZ130[48,60]{3,4}AB | Goodman <u>S</u> plit <u>Z</u> R410A Heat Pump 13 Seer heat pump units. Relocation of low pressure switch from liquid line to suction line as a compressor safeguard to prevent low pressure from entering.   |
| GSZ130[18,42,48]1AF<br>GSZ130301AG<br>GSZ130[36,48]3AD<br>GSZ130484AC                    | Goodman <u>S</u> plit <u>Z</u> R410A Heat Pump 13 Seer heat pump units. Changing from the current four piece louver assembly, to a two piece louver plus a corner post on Goodman and value series 26" and 29" chassis.   |
| GSZ130361BC<br>GSZ130[42 & 48]1AE  | Goodman <u>S</u> plit <u>Z</u> R410A Heat Pump 13 Seer heat pump units. Release of models with new 6 pole motor/fan combination.  |
| GSZ130361BD  | Goodman <u>S</u> plit <u>Z</u> R410A Heat Pump 13 Seer heat pump units. Models with new 6 pole motor/fan combination. Changing from the current four piece louver assembly, to a two piece louver plus a corner post on Goodman and value series 26" and 29" chassis. |
| GSZ130421AF  | Goodman <u>S</u> plit <u>Z</u> R410A Heat Pump 13 Seer heat pump units. Release of two piece louver plus corner post on 26" and 29" chassis with compressor changing from ZP36K5EPFV130 to ZP34K5EPFV130.   |
| GSZ130[36 & 48]3AC   | Goodman <u>S</u> plit <u>Z</u> R410A Heat Pump 13 Seer heat pump units. Release of 3 phase models with new 6 pole motor.  |
| GSZ14**1AA   | Goodman <u>S</u> plit <u>Z</u> R410A Heat Pump 14 Seer heat pump units. Initial release of 14 SEER models.  |
| GSZ130481AG<br>GSZ130483AE<br>GSZ130484AD  | Goodman <u>S</u> plit <u>Z</u> R410A Heat Pump 13 Seer heat pump units. Current Ranco reversing valve 0151M00020 replaced by SanHua 0151R00070 reversing valve  |



# PRODUCT IDENTIFICATION

| Split System Heat Pumps R410A   |   |
|---|---|
| Model #   | Description   |
| SSZ140**1AA   | Special High Feature <u>S</u> plit <u>Z</u> R410A heat pump 14 Seer heat pump units. Initial release of Goodman 14 SEER Heat Pump R410A.  |
| SSZ140**1AB   | Special High Feature <u>S</u> plit <u>Z</u> R410A heat pump 14 Seer heat pump units. Introduces new revisions have screw locations moved in the top panel, base pans, louvers, and control box covers.  |
| SSZ140**1AC   | Special High Feature <u>S</u> plit <u>Z</u> R410A heat pump 14 Seer heat pump units. Models contain Broad Ocean motors.   |
| SSZ140181AC<br>SSZ140241AF<br>SSZ140301AD   | Special High Feature <u>S</u> plit <u>Z</u> R410A heat pump 14 Seer heat pump units. Introduces new revisions adding mufflers to the discharge line.  |
| SSZ140361AF<br>SSZ140421AD<br>SSZ140[48-60]1AD  | Special High Feature <u>S</u> plit <u>Z</u> R410A heat pump 14 Seer heat pump units. New revisions replace TXV & compensator with flowrator & accumulator; adds mufflers on SSZ14036', 421, 481, 601.   |
| SSZ140[18, 30, 42-60]1AE<br>SSZ140241AH<br>SSZ14036]1AG   | Special High Feature <u>S</u> plit <u>Z</u> R410A heat pump 14 Seer heat pump units. New revisions will have Sanhua (RANCO) reversing valves.   |
| SSZ140[18,30,42-60]1AF<br>SSZ140241AJ<br>SSZ160361AH  | Special High Feature <u>S</u> plit <u>Z</u> R410A heat pump 14 Seer heat pump units. Introduces models containing an accumulator, crankcase heater, and upgraded defrost control.   |
| SSZ140[18 & 30]1AH<br>SSZ140241AL<br>SSZ140361BB  | Special High Feature <u>S</u> plit <u>Z</u> R410A heat pump 14 Seer heat pump units. Changing from the current four piece louver assembly, to a two piece louver plus a corner post on Goodman and value series 26" and 29" chassis.          |
| SSZ140[18 & 30]1AJ<br>SSZ140[19,25,31,37]1AC<br>SSZ140241AM<br>SSZ140361BC<br>SSZ140381AB<br>SSZ140[42-60]1AH | Special High Feature <u>S</u> plit <u>Z</u> R410A heat pump 14 Seer heat pump units. Revision made for design improvement.  |
| SSZ140241AG   | Special High Feature <u>S</u> plit <u>Z</u> R410A heat pump 14 Seer heat pump units. AG revision has the smaller B1227315 reversing valve.  |
| SSZ140[18-60]1AD  | Special High Feature <u>S</u> plit <u>Z</u> R410A heat pump 14 Seer heat pump units. Relocation of low pressure switch from liquid line to suction line as a compressor safeguard to prevent low pressure from entering.                      |
| SSZ140361AF<br>SSZ140421AD<br>SSZ140[48-60]1AD  | Special High Feature <u>S</u> plit <u>Z</u> R410A heat pump 14 Seer heat pump units. Initial release of Goodman 14 SEER Heat Pump R410A, with reduced chassis size from large to medium.  |
| SSZ140381AA   | Special High Feature <u>S</u> plit <u>Z</u> R410A heat pump 14 Seer heat pump units. 35" chassis with 6-channel flowrator and ZP29K5 compressor.  |
| SSZ140[18-30]1BA  | Special High Feature <u>S</u> plit <u>Z</u> R410A heat pump 14 Seer heat pump units. Updating ratings and agency information.   |
| SSZ160**1AA   | Special High Feature <u>S</u> plit <u>Z</u> R410A heat pump 16 Seer heat pump units. Initial release of Goodman 16 SEER Heat Pump R410A.  |
| SSZ160**1AB   | Special High Feature <u>S</u> plit <u>Z</u> R410A heat pump 16 Seer heat pump units. Introduces new revisions have screw locations moved in the top panel, base pans, louvers, and control box covers.  |
| SSZ160[24-48]1AC<br>SSZ160601AD   | Special High Feature <u>S</u> plit <u>Z</u> R410A heat pump 16 Seer heat pump units. Introduces new revisions adding mufflers to the discharge line.  |
| SSZ160**1AC   | Special High Feature <u>S</u> plit <u>Z</u> R410A heat pump 16 Seer heat pump units. Introduces models containing the Broad Ocean motor and added Muffler and standardized TXV, Compensator using the ASZ18 Seer weldment to the SSZ160601AC. |
| SSZ160241AF<br>SSZ160[36, 48]1AD<br>SSZ160601AE   | Special High Feature <u>S</u> plit <u>Z</u> R410A heat pump 16 Seer heat pump units. New revisions will have Sanhua (RANCO) reversing valves.   |
| SSZ160241AG<br>SSZ160[36-48]1AE<br>SSZ160601BA  | Special High Feature <u>S</u> plit <u>Z</u> R410A heat pump 16 Seer heat pump units. Introduces models containing an accumulator, crankcase heater, and upgraded defrost control.   |
| SSZ160241AH   | Special High Feature <u>S</u> plit <u>Z</u> R410A heat pump 16 Seer heat pump units. Changing from the current four piece louver assembly, to a two piece louver plus a corner post on Goodman and value series 26" and 29" chassis.          |
| SSZ160601BB   | Special High Feature <u>S</u> plit <u>Z</u> R410A heat pump 16 Seer heat pump units. Introduces Ultratech® compressor changes.  |

# PRODUCT IDENTIFICATION

| Split System Heat Pumps R410A                               |   |
|---|---|
| Model #   | Description   |
| VSZ13**1AA  | Value <u>S</u> plit <u>Z</u> heat pump, 13 Seer R410A heat pump units. Introduces Value Line 13 SEER heat pumps with R-410A.  |
| VSZ130[24 & 30]1AB  | Value <u>S</u> plit <u>Z</u> heat pump, 13 Seer R410A heat pump units. Introduces new revisions with improved circuiting for effective defrost.   |
| VSZ130[24 & 36]1BA  | Value <u>S</u> plit <u>Z</u> heat pump, 13 Seer R410A heat pump units. Initial release of models with 5mm Smart Coil™.  |
| VSZ130[18, 42, 48]1AB<br>VSZ130241BB<br>VSZ130301AC         | Value <u>S</u> plit <u>Z</u> heat pump, 13 Seer R410A heat pump units. Introduces models containing crankcase heater, CCH switch and upgraded defrost control.  |
| VSZ130181AE   | Value <u>S</u> plit <u>Z</u> heat pump, 13 Seer R410A heat pump units. Changing from the current four piece louver assembly, to a two piece louver plus a corner post on Goodman and value series 26" and 29" chassis.  |
| VSZ130[24 & 36]1BC<br>VSZ130301AE<br>VSZ130[18, 42 & 48]1AD | Value <u>S</u> plit <u>Z</u> heat pump, 13 Seer R410A heat pump units. Release of single phase models with new 6 pole motor.  |
| VSZ130361BD<br>VSZ130301AF<br>VSZ130481AE                   | Value <u>S</u> plit <u>Z</u> heat pump, 13 Seer R410A heat pump units. Single phase models with new 6 pole motor. Changing from the current four piece louver assembly, to a two piece louver plus a corner post on Goodman and value series 26" and 29" chassis. |
| VSZ130[18, 42-60]1AC<br>VSZ130301AD                         | Value <u>S</u> plit <u>Z</u> heat pump, 13 Seer R410A heat pump units. Relocation of low pressure switch from liquid line to suction line as a compressor safeguard to prevent low pressure from entering.  |
| VSZ130421AF   | Value <u>S</u> plit <u>Z</u> heat pump, 13 Seer R410 heat pump units. Release of two piece louver plus corner post on 26" and 29" chassis with compressor changing from ZP36K5EPFV130 to ZP34K5EPFV130.   |
| VSZ130241CA   | Value <u>S</u> plit <u>Z</u> heat pump, 13 Seer R410A heat pump units. Release of 2 Ton models with a compressor change from ZP21K5EPFV130 to ZP20K5EPFV130.  |
| VSZ130241CB   | Value <u>S</u> plit <u>Z</u> heat pump, 13 Seer R410A heat pump units. 2 Ton models changing from the current four piece louver assembly, to a two piece louver plus a corner post on Goodman and value series 26" and 29" chassis.                               |
| VSZ130181AF<br>VSZ130241BD<br>VSZ130301AG                   | Value <u>S</u> plit <u>Z</u> heat pump, 13 Seer R410A heat pump units. Current reversing valve change from Dunan to new SanHua reversing valve  |
| VSZ130481AF   | Value <u>S</u> plit <u>Z</u> heat pump, 13 Seer R410A heat pump units. Current Ranco reversing valve 0151M00020 replaced by SanHua 0151R00070 reversing valve   |

# PRODUCT IDENTIFICATION

| Split System Air Conditioners R410A                      |  |
|--|--|
| Model #  | Description  |
| GSX130**1AA  | Goodman <u>S</u> plit <u>X</u> Condenser 13 Seer condensing units. Introduction of Goodman 13 SEER R-410A Condensers with Regal Beloit motors  |
| GSX13061[1/3/4]AA  | Goodman <u>S</u> plit <u>X</u> Condenser 13 Seer condensing units. Introduction of Goodman 13 SEER R-410A Condensers that supplement our current 5 ton models.   |
| GSX130363AB  | Goodman <u>S</u> plit <u>X</u> Condenser 13 Seer condensing units. Condensers that supplement Goodman's current 5 ton models changing from the current four piece louver assembly, to a two piece louver plus a corner post on Goodman and value series 26" and 29" chassis. |
| GSX130**1AB  | Goodman <u>S</u> plit <u>X</u> Condenser 13 Seer condensing units. Introduction of Goodman 13 SEER R-410A Condensers with Broad Ocean motors.  |
| GSX130[42 & 48]1BB                                       | Goodman <u>S</u> plit <u>X</u> Condenser 13 Seer condensing units. Release of models with new 6 pole motor/fan combination.  |
| GSX130[42 & 48]1BC                                       | Goodman <u>S</u> plit <u>X</u> Condenser 13 Seer condensing units. Changing from the current four piece louver assembly, to a two piece louver plus a corner post on Goodman and value series 26" and 29" chassis.   |
| GSX130483AB  | Goodman <u>S</u> plit <u>X</u> Condenser 13 Seer condensing units. Release of 3 phase model with new 6 pole motor.   |
| GSX130483AC  | Goodman <u>S</u> plit <u>X</u> Condenser 13 Seer condensing units. 3 phase model changing from the current four piece louver assembly, to a two piece louver plus a corner post on Goodman and value series 26" and 29" chassis.   |
| GSX130181EA<br>GSX130181EB                               | Goodman <u>S</u> plit <u>X</u> Condenser 13 Seer condensing units. Introduction of 1.5 ton condenser with Rechi Compressor.  |
| GSX130**1BA<br>GSX130**3AA<br>GSX130**4AA                | Goodman <u>S</u> plit <u>X</u> Condenser 13 Seer condensing units. Introduction of Goodman 13 SEER R-410A Condensers, using SmartCoil® coils. Units will have new louvers because units are smaller. Piston size change. Other components unchanged.                         |
| GSX130484AB<br>GSX130601BB<br>GSX130603AB<br>GSX130604AB | Goodman <u>S</u> plit <u>X</u> Condenser 13 Seer condensing units. Introduction of Goodman 13 SEER R-410A Condensers, changing from the current four piece louver assembly, to a two piece louver plus a corner post on Goodman and value series 26" and 29" chassis.        |
| GSX130301BB  | Goodman <u>S</u> plit <u>X</u> Condenser 13 Seer condensing units. 13 SEER R-410A Condensers: replacing the fan motor to -294 and fan blade to -18 on GSX130301BA models.  |

# PRODUCT IDENTIFICATION

| Split System Air Conditioners R410A   |   |
|---|---|
| Model #   | Description   |
| GSX130301BC   | <u>Goodman Split X</u> Condenser 13 Seer condensing units. 13 SEER R-410A Condensers: changing from the current four piece louver assembly, to a two piece louver plus a corner post on Goodman and value series 26" and 29" chassis.   |
| GSX130181CA   | <u>Goodman Split X</u> Condenser 13 Seer condensing units. Introduction of Goodman 1.5 ton 13 SEER R-410A Condensers with rotary compressor.  |
| GSX130361CA   | <u>Goodman Split X</u> Condenser 13 Seer condensing units. 13 SEER R-410A Condensers: replacing current compressor with compressor ZP29K5EPFV130.   |
| GSX130[18-36]1DA  | <u>Goodman Split X</u> Condenser 13 Seer condensing units. Introduction of Goodman 1.5 ton 13 SEER R-410A Condensers conversion to 23" chassis for the 1.5 - 3 ton models.  |
| GSX130181ED   | <u>Goodman Split X</u> Condenser 13 Seer condensing units. Introduction of Rev ED. This involves changing from 4 leg Rechi Compressor 50N382XV-ZAKM to 3 Leg Rechi Compressor 50N382XV-5AKM and change in Suction line Assy from 0210R01608 to 0210R01406. This minor rev change also would include revising quantity of both Grommet (60140209) & Screw (0163M00186) from 4 pcs to 3pcs. |
| GSX13031DB  | <u>Goodman Split X</u> Condenser 13 Seer condensing units. Introduction of Goodman 2.5 ton units with improved coil circuit assembly for greater capacity/efficiency and the creation of a new discharge tubing assembly.   |
| GSX130361EA   | <u>Goodman Split X</u> Condenser 13 Seer condensing units. Introduction of Goodman 3 ton conversion from 29" chassis to 26".  |
| GSX130361EB   | <u>Goodman Split X</u> Condenser 13 Seer condensing units. Changing from the current four piece louver assembly, to a two piece louver plus a corner post on Goodman and value series 26" and 29" chassis.  |
| GSX130371AA   | <u>Goodman Split X</u> condensing units, 13 Seer R410A condensing units. Introduction of 2.5 13 SEER Condensers with improved decibel ratings for Canadian market.  |
| GSX14**1AA  | <u>Goodman Split X</u> 14 Seer Condensing units. Introduction of Goodman 14 SEER R-410A models.   |
| GSX140[18-19]1KA<br>GSX140[24-25]1KA<br>GSX140[30-31]1KA<br>GSX140[36-37]1KA<br>GSX140[42, 48, 60]1KA | <u>Goodman Split X</u> 14 Seer Condensing units. Introducing the Goodman 14 SEER standard condenser 5mm architecture with updated scroll compressors.   |
| GSX150[18-60]AA   | <u>Goodman Split X</u> 15 Seer Condensing units. Initial release of models with coil and TVX. Replacing the current ASX/SSX14 lineup.   |
| GSX160**1FA   | <u>Goodman Split X</u> 16 Seer Condensing units. Initial release of the Goodman 15 SEER AC R410A Condensers.  |
| GSX160611FA   | <u>Goodman Split X</u> 16 Seer Condensing units. Set up of new high capacity 5 ton models that will supplement the current GSX160601 models.  |
| GSX160[18-61]1FB  | <u>Goodman Split X</u> 16 Seer Condensing units. Minor revision for GSX16s to include ball valves 0151R00045 and 0151R00046.  |
| GSX160601GA   | <u>Goodman Split X</u> 16 Seer Condensing units. Transitioning to 7mm coils.  |

# PRODUCT IDENTIFICATION

| Split System Air Conditioners R410A                           |   |
|---|---|
| Model #   | Description   |
| SSX140**1AA   | Special High Feature <u>S</u> plit <u>X</u> Condenser 14 Seer condensing units. Initial release of Goodman 14 SEER AC 410A.   |
| SSX140**1AB   | Special High Feature <u>S</u> plit <u>X</u> Condenser 14 Seer condensing units. Revisions have screw locations moved in the top panel, base pans, louvers, and control box covers.  |
| SSX14018, 241AC   | Special High Feature <u>S</u> plit <u>X</u> Condenser 14 Seer condensing units. Revised condenser coils by removing [1] harpin.   |
| SSX140301AC   | Special High Feature <u>S</u> plit <u>X</u> Condenser 14 Seer condensing units. Model contains the Broad Ocean motor 0131M00060   |
| SSX14036-601AC  | Special High Feature <u>S</u> plit <u>X</u> Condenser 14 Seer condensing units. Models contain the Broad Ocean motor 0131M00061   |
| SSX140421AD   | Special High Feature <u>S</u> plit <u>X</u> Condenser 14 Seer condensing units. Introduces SSX140421A in 29" base pan   |
| SSX140[18-24]1BA<br>SSX140[30-36]1BA<br>SSX140421CA           | Special High Feature <u>S</u> plit <u>X</u> Condenser 14 Seer condensing units. Converts 1.5 - 3.5 ton condenser coil tubes from 3/8" tube diameter to 5mm tube diameter.   |
| SSX140[18-36]1BC<br>SSX140421CC                               | Special High Feature <u>S</u> plit <u>X</u> Condenser 14 Seer condensing units. Changing from the current four piece louver assembly, to a two piece louver plus a corner post on Goodman and value series 26" and 29" chassis.                     |
| SSX140[18-36]1BD<br>SSX140421CD<br>SSX140481BB<br>SSX140601AG | Special High Feature <u>S</u> plit <u>X</u> Condenser 14 Seer condensing units. Revision made for design improvement.   |
| SSX140421BA   | Special High Feature <u>S</u> plit <u>X</u> Condenser 14 Seer condensing units. Revision for SSZ140421B* in 29 base pan and it will the reduce the unit charge from 180 oz. to 170 oz. and replace the 1/4 hp outdoor unit motor with 1/6 hp motor. |
| SSX14030-421AE  | Special High Feature <u>S</u> plit <u>X</u> Condenser 14 Seer condensing units. Revised condenser coils by removing [1] harpin.   |
| SSX140[18-48]1BA<br>SSX14042-481CA                            | Special High Feature <u>S</u> plit <u>X</u> Condenser 14 Seer condensing units. Introduction of Goodman 14 SEER R-410A Condensers, using SmartCoil® Coils.  |
| SSX140[18-36]1BB<br>SSX140421CB<br>SSX140601AF                | Special High Feature <u>S</u> plit <u>X</u> Condenser 14 Seer condensing units. Relocation of low pressure switch from liquid line to suction line as a compressor safeguard to prevent low pressure from entering.                                 |
| SSX160**1AA   | Special High Feature <u>S</u> plit <u>X</u> Condenser 16 Seer condensing units. Introduces Goodman 16 SEER AC 410A  |
| SSX160**1AB   | Special High Feature <u>S</u> plit <u>X</u> Condenser 16 Seer condensing units. New revisions have screw locations moved in the top panel, base pans, louvers, and control box covers.  |
| SSX160**1AB<br>SSX160591AA                                    | Special High Feature <u>S</u> plit <u>X</u> Condenser 16 Seer condensing units. New revisions have screw locations moved in the top panel, base pans, louvers, and control box covers.  |
| SSX160[24, 36, 48]1BA<br>SSX160[30 & 42]1AA                   | Special High Feature <u>S</u> plit <u>X</u> Condenser 16 Seer condensing units. New revisions have SmartCoil® coils.  |
| SSX160[24 & 36]1BC<br>SSX160[30 & 42]1AB                      | Special High Feature <u>S</u> plit <u>X</u> Condenser 16 Seer condensing units. Changing from the current four piece louver assembly, to a two piece louver plus a corner post on Goodman and value series 26" and 29" chassis.                     |
| SSX160601BA   | Special High Feature <u>S</u> plit <u>X</u> Condenser 16 Seer condensing units. New "BA" revision models use ZPS49K compressor.   |
| SSX160[24,36,60]1BB   | Special High Feature <u>S</u> plit <u>X</u> Condenser 16 Seer condensing units. Relocation of low pressure switch from liquid line to suction line as a compressor safeguard to prevent low pressure from entering.                                 |

# PRODUCT IDENTIFICATION

| Split System Air Conditioners R410A |  |
|-------------------------------------|--|
| Model #                             | Description  |
| DSX160**1AA                         | <u>D</u> eluxe <u>S</u> plit <u>X</u> Condenser 16 Seer condensing units. Introduces Goodman 2-stage, 16 SEER condensing units with R-410A.  |
| DSX160[24 & 36]1BA                  | <u>D</u> eluxe <u>S</u> plit <u>X</u> Condenser 16 Seer condensing units. Goodman 2-stage, 16 SEER condensing units with R-410A. Conversion of 2 & 3 ton models to SmartCoil® Coils.   |
| DSX160241BC                         | <u>D</u> eluxe <u>S</u> plit <u>X</u> Condenser 16 Seer condensing units. Goodman 2-stage, 16 SEER condensing units with R-410A. Introduces Ultratech® 2.0 compressor changes.   |
| DSX180**1AA                         | <u>D</u> eluxe <u>S</u> plit <u>X</u> Condenser 18 Seer condensing units. Introduces Goodman 2-stage, 18 SEER condensing units with R-410A.  |
| DSXC16**1AA                         | <u>D</u> eluxe <u>S</u> plit <u>X</u> <u>C</u> ommunicating condensing units, 16 Seer R410A condensing units. Introduces Goodman 2-stage 16 SEER condensing units with R-410A, communicating models.   |
| DSXC160[24, 36]1AB                  | <u>D</u> eluxe <u>S</u> plit <u>X</u> <u>C</u> ommunicating condensing units, 16 Seer R410A condensing units. New revision updates wiring diagram with notes.  |
| DSXC160[24, 36]1AC                  | <u>D</u> eluxe <u>S</u> plit <u>X</u> <u>C</u> ommunicating condensing units, 16 Seer R410A condensing units. Introduces Ultratech® 2.0 compressor changes.  |
| DSXC160481BA                        | <u>D</u> eluxe <u>S</u> plit <u>X</u> Condenser 16 Seer condensing units. Goodman 2-stage, 16 SEER condensing units with R-410A, using SmartCoil® coils.   |
| DSXC160601BA                        | <u>D</u> eluxe <u>S</u> plit <u>X</u> <u>C</u> ommunicating condensing units, 16 Seer R410A condensing units. Introduces Goodman 2-stage 16 SEER condensing units with R-410A, communicating models. New "BA" revision models use ZPS49K compressor. |
| DSXC160[48-60]1BB                   | <u>D</u> eluxe <u>S</u> plit <u>X</u> <u>C</u> ommunicating condensing units, 16 Seer R410A condensing units. Introduces Goodman 2-stage 16 SEER condensing units with R-410A, communicating models. Changes motor to Nidec.                         |
| DSXC160[48-60]1BC                   | <u>D</u> eluxe <u>S</u> plit <u>X</u> <u>C</u> ommunicating condensing units, 16 Seer R410A condensing units. Introduces Goodman 2-stage 16 SEER condensing units with R-410A, communicating models. Introduces Ultratech 2.0 compressor.            |
| DSXC160601CA                        | <u>D</u> eluxe <u>S</u> plit <u>X</u> <u>C</u> ommunicating condensing units, 16 Seer R410A condensing transitioning to 7 mm coils.  |
| DSXC18**1AA                         | <u>D</u> eluxe <u>S</u> plit <u>X</u> <u>C</u> ommunicating condensing units, 18 Seer R410A condensing units. Introduces Goodman 2-stage 18 SEER condensing units with R-410A, communicating models.   |
| DSXC180[36, 48, 60]AB               | <u>D</u> eluxe <u>S</u> plit <u>X</u> <u>C</u> ommunicating condensing units, 18 Seer R410A condensing units. New revision updates wiring diagram with notes.  |
| DSXC18036AC                         | <u>D</u> eluxe <u>S</u> plit <u>X</u> <u>C</u> ommunicating condensing units, 18 Seer R410A condensing units. New revision replaces existing compressor ZPS20K4EPFV230 to ZPS20K5EPFV130 & existing compressor ZPS30K4EPFV230 to ZPS30K5EPFV130.     |
| DSXC180[48-60]AC                    | <u>D</u> eluxe <u>S</u> plit <u>X</u> <u>C</u> ommunicating condensing units, 18 Seer R410A condensing units. Introduces Ultratech 2.0.  |

# PRODUCT IDENTIFICATION

| Split System Air Conditioners R410A |   |
|-------------------------------------|---|
| Model #                             | Description   |
| VSX130[18-48]1AA                    | Value Split X condensing units, 13 Seer R410A condensing units. Introduces Value Line 13 SEER condensing units with R-410A.   |
| VSX130611AA                         | Value Split X condensing units, 13 Seer R410A condensing units. Supplements the 5 ton model GSX130611 to enhance performance.   |
| VSX130301AB                         | Value Split X condensing units, 13 Seer R410A condensing units: replacing the fan motor to -294 and fan blade to -18 on the VSX130301AA.  |
| VSX130301AC                         | Value Split X condensing units, 13 Seer R410A condensing units: changing from the current four piece louver assembly, to a two piece louver plus a corner post on Goodman and value series 26" and 29" chassis.   |
| VSX130[42-48]1AB                    | Value Split X condensing units, 13 Seer R410A condensing units: replacing with 6-pole motor and Copeland compressor.  |
| VSX130[42-48]1AC                    | Value Split X condensing units, 13 Seer R410A condensing units: changing from the current four piece louver assembly, to a two piece louver plus a corner post on Goodman and value series 26" and 29" chassis.   |
| VSX130181BA                         | Value Split X condensing units, 13 Seer R410A condensing units. Introduces Value Line 13 SEER 1.5 ton condensing units with R-410A, with rotary compressors   |
| VSX130181EA<br>VSX130181EB          | Value Split X condensing units, 13 Seer R410A condensing units. Introduction of 1.5 ton condenser with Rechi Compressor.  |
| VSX130181ED                         | Value Split X condensing units, 13 Seer R410A condensing units. Introduction of Rev ED. This involves changing from 4 leg Rechi Compressor 50N382XV-ZAKM to 3 Leg Rechi Compressor 50N382XV-5AKM and change in Suction line Assy from 0210R01608 to 0210R01406. This minor rev change also would include revising quantity of both Grommet (60140209) & Screw (0163M00186) from 4pcs to 3pcs. |
| VSX130241BA                         | Value Split X condensing units, 13 Seer R410A condensing units. Introduces Value Line 13 SEER 2.0 ton condensing units with R-410A, with aluminum coils, aluminum manifolds w/existing scroll compressor.   |
| VSX130361BA                         | Value Split X condensing units 13 Seer R410A condensing units. 13 SEER R-410A Condensers: replacing current compressor with compressor ZP29K5EPFV130.   |
| VSX130361EB                         | Value Split X condensing units 13 Seer R410A condensing units. 13 SEER R-410A Condensers: changing from the current four piece louver assembly, to a two piece louver plus a corner post on Goodman and value series 26" and 29" chassis.   |
| VSX130601BA                         | Value Split X condensing units, 13 Seer R410A condensing units. Introduces Value Line 13 SEER condensing units with R-410A, using SmartCoil® coils.   |
| VSX130601BB                         | Value Split X condensing units, 13 Seer R410A condensing units. Changing from the current four piece louver assembly, to a two piece louver plus a corner post on Goodman and value series 26" and 29" chassis.   |
| VSX130421BA<br>VSX130481BA          | Value Split X condensing units, 13 Seer R410A condensing units. Introduction of Value Line 3.5 and 4 ton 13 SEER condensing units with reciprocating compressor.  |
| VSX130[18-36]1DA                    | Value Split X condensing units, 13 Seer R410A condensing units. Introduction of Value Line 3.5 and 4 ton 13 SEER Condensers conversion to 23" chassis for the 1.5 - 3 ton models.   |
| VSX130301DB                         | Value Split X condensing units, 13 Seer R410A condensing units. Introduction of Value Line 2.5 13 SEER Condensers with improved coil circuit assembly for greater capacity/efficiency and the creation of a new discharge tubing assembly.  |
| VSX130301EA                         | Value Split X condensing units, 13 Seer R410A condensing units. Introduction of Value Line 3 Ton 13 SEER Condensers release of 3 ton models converting from 29" chassis to 26" chassis.   |
| VSX130241EA                         | Value Split X condensing units, 13 Seer R410A condensing units. Introduction of Value Line 2.0 Ton 13 SEER Condensers with Rechi Compressor, converting 23" chassis to 26" chassis  |
| VSX130371AA                         | Value Split X condensing units, 13 Seer R410A condensing units. Introduction of Value Line 2.5 13 SEER Condensers with improved decibel ratings for Canadian market.  |
| VSX130241EB                         | Value Split X condensing units, 13 Seer R410A condensing units. Change made due to all 3 compressor wires yellow, red and black changing from 40" to 45".   |

# PRODUCT IDENTIFICATION

| Split System Air Conditioners R410A   |  |
|---|--|
| Model #   | Description  |
| VSX140[18-19]1AA<br>VSX140[24-25]1AA<br>VSX140[30-31]1AA<br>VSX140[36-37]1AA<br>VSX140[42, 48, 60]1AA | Value Split X condensing units, 14 Seer R410A condensing units. Introducing the 14 SEER standard condenser 5mm architecture with updated scroll compressors. |

| Split System Air Conditioners R410A |  |
|-------------------------------------|--|
| Model #                             | Description  |
| ANX130[18-24]1AA                    | Amana® Brand Split System Base Condenser. 13 Seer R-410A condensing unit. Launch of the Tier 1.5T & 2.0T models. To be launched with 26" chasis to accommodate horizontal style louvers. |
| ANX130[30-61]1AA                    | Amana® Brand Split System Base Condenser. 13 Seer R-410A condensing unit.  |

| Split System Air Conditioners R410A |   |
|-------------------------------------|---|
| Model #                             | Description   |
| ANX140[18-60]1AA                    | Amana® Brand Split System Base Condenser. 14 Seer R-410A condensing unit. Introducing the Amana® Brand 14 SEER standard condenser 5mm architecture with updated scroll compressors. |



# PRODUCT IDENTIFICATION

| Split System Air Conditioners R410A   |   |
|---|---|
| Model #   | Description   |
| ASX130**1AA   | Amana® Brand Split X Condenser 13 Seer condensing units. Initial release new models of Amana® Brand Deluxe 13 SEER AC R410A conditioners.   |
| ASX130611AA   | Amana® Brand Split X Condenser 13 Seer condensing units. Introduction of Amana® brand 13 SEER R-410A Condensers that supplement our current 5 ton models.   |
| ASX130**1BA   | Amana® Brand Split X Condenser 13 Seer condensing units. Introduction of Amana® Brand 13 SEER R-410A Condensers, using SmartCoil® coils. Units will have new louvers since units are smaller. Piston size change; other components unchanged. |
| ASX130**1CB   | Amana® Brand Split X Condenser 13 Seer condensing units. Relocation of low pressure switch from liquid line to suction line as a compressor safeguard to prevent low pressure from entering.  |
| ASX130181DA<br>ASX140181DA  | Amana® Brand Split X Condenser 13 Seer condensing units. Initial release of models going from 2-speed fan to new 266 fan motor; removal of low pressure switch.   |
| ASX130181DB<br>ASX130[24-48]1CD<br>ASX130601CC  | Amana® Brand Split X Condenser 13 Seer condensing units. Changes include adding low pressure switch 013M00082, updating wiring diagram.   |
| ASX130[24-48]1CC<br>ASX130601CB   | Amana® Brand Split X Condenser 13 Seer condensing units. Initial release of models using single speed PSC motors; removal of low pressure switch and low ambient temperature switch and relay.  |
| ASX130361DA   | Amana® Brand Split X Condenser 13 Seer condensing units. Release of 3 ton models converting from 29" chassis to 26" chassis.  |
| ASX140**1AA   | Amana® Brand Split X Condenser 14 Seer condensing units. Initial release new models of Amana® Brand Deluxe 14 SEER AC R410A conditioners.   |
| ASX140**1AB   | Amana® Brand Split X Condenser 14 Seer condensing units. New revisions have screw locations moved in the top panel, base pans, louvers, and control box covers.   |
| ASX140**1AC   | Amana® Brand Split X Condenser 14 Seer condensing units. The new revisions have horizontal style louvers.   |
| ASX14018-361AD  | Amana® Brand Split X Condenser 14 Seer condensing units. Revised condenser coils by removing (1) hairpin. Reduce R410A quantity by 6 ounces   |
| ASX140421AD   | Amana® Brand Split X Condenser 14 Seer condensing units. Introduces ASX140421A in 29" base pan  |
| ASX14018-361BA<br>ASX140[42-48]1CA  | Amana® Brand Split Condenser 14 Seer condensing units. Converts 1.5 - 3.5 ton condenser coil tubes from 3/8" tube diameter to 5mm tube diameter.  |
| ASX140[18-30]1BA<br>ASX140[42-48]1CA  | Amana® Brand Split X Condenser 14 Seer condensing units. Introduction of Amana® Brand 14 SEER R-410A Condensers, using SmartCoil® coils..   |
| ASX140[18-36]1CB<br>ASX140421DB<br>ASX140601BB  | Amana® Brand Split X Condenser 14 Seer condensing units. Relocation of low pressure switch from liquid line to suction line as a compressor safeguard to prevent low pressure from entering.  |
| ASX140[24-36]1CC<br>ASX140421DC<br>ASX140481CB<br>ASX140601BC   | Amana® Brand Split X Condenser 14 Seer condensing units. Initial release of models using single speed PSC motors; removal of low pressure switch and low ambient temperature switch and relay.  |
| ASX140181DB<br>ASX140[24-36]1CD<br>ASX140421DD<br>ASX140481CC<br>ASX140601BD                          | Amana® Brand Split X Condenser 14 Seer condensing units. Revision adds low pressure switch into models.   |
| ASX150[18-60]AA   | Amana® Brand Split X Condenser 15 Seer condensing units. Initial release of models with coil and TVX. Replacing the current ASX/SSX14 lineup.   |
| ASX140181DD<br>ASX140[24-36]1CE<br>ASX140421DE<br>ASX140481CE<br>ASX140601BE                          | Amana® Brand Split X Condenser 14 Seer condensing units. Revision made for design improvement.  |
| ASX140[18-19]1KA<br>ASX140[24-25]1KA<br>ASX140[30-31]1KA<br>ASX140[36-37]1KA<br>ASX140[42, 48, 60]1KA | Amana® Brand Split X Condenser 14 Seer condensing units. Introducing the Amana® Brand 14 SEER standard condenser 5mm architecture with updated scroll compressors.  |

# PRODUCT IDENTIFICATION

| Split System Air Conditioners R410A |  |
|-------------------------------------|--|
| Model #                             | Description  |
| ASX160**1AB                         | Amana® Brand <u>S</u> plit <u>X</u> Condenser 16 Seer condensing units. New revisions have screw locations moved in the top panel, base pans, louvers, and control box covers. |
| ASX160**1AC                         | Amana® Brand <u>S</u> plit <u>X</u> Condenser 16 Seer condensing units. The new revisions have horizontal style louvers.   |
| ASX160**1FA                         | Amana® Brand <u>S</u> plit <u>X</u> Condenser 16 Seer condensing units. The new revision has single speed outdoor fan.   |
| ASX160611FA                         | Amana® Brand <u>S</u> plit <u>X</u> Condenser 16 Seer condensing units. Set up of new high capacity 5 ton models that will supplement the current ASX160601 models.            |
| ASX160611GA                         | Amana® Brand <u>S</u> plit <u>X</u> Condenser 16 Seer condensing units. Transitioning to 7mm coils.<br>— —   |
| ASX160[24-60]1BA                    | Amana® Brand <u>S</u> plit <u>X</u> Condenser 16 Seer condensing units. New revision updates wiring diagram with notes.  |
| ASX160[24 & 36]1CA                  | Amana® Brand <u>S</u> plit <u>X</u> Condenser 16 Seer condensing units. Introduction of 16 SEER R-410A Condensers. Conversion of 2 & 3 ton models to SmartCoil® coils.         |
| ASX180**1AB                         | Amana® Brand <u>S</u> plit <u>X</u> Condenser 18 Seer condensing units. Initial release new models of Amana® Brand Deluxe 16 SEER AC R410A conditioners.                       |

| Split System Air Conditioners R410A     |   |
|---|---|
| Model #                                 | Description   |
| ASXC160**1AA                            | Amana® brand <u>S</u> plit <u>X</u> <u>C</u> ommunicating condensing units, 16 Seer R410A. Introduces Amana® brand 2-stage 16 SEER condensing units with R-410A, communicating models.  |
| ASXC160601BA                            | Amana® brand <u>S</u> plit <u>X</u> <u>C</u> ommunicating condensing units, 16 Seer R410A heat pump units. Introduces Amana® brand 2-stage 16 SEER condensing units with R-410A, communicating models. New "BA" revisions use ZPS49 compressor. |
| ASXC160481BA                            | Amana® brand <u>S</u> plit <u>X</u> <u>C</u> ommunicating condensing units, 16 Seer R410A condensing units. Introduction of Amana® brand 16 SEER condensing units with R-410A. New revisions have SmartCoil® coils                              |
| ASXC160[24, 36]1BB                      | Amana® brand <u>S</u> plit <u>X</u> <u>C</u> ommunicating condensing units, 16 Seer R410A condensing units. New revision updates wiring diagram with notes.   |
| ASXC160[48-60]1BB                       | Amana® brand <u>S</u> plit <u>X</u> <u>C</u> ommunicating condensing units, 16 Seer R410A condensing units. Changes motor to Nidec.   |
| ASXC160[24, 36]1BC<br>ASXC160[48-60]1BC | Amana® brand <u>S</u> plit <u>X</u> <u>C</u> ommunicating condensing units, 16 Seer R410A condensing units. Introduces Ultratech® 2.0 compressor changes.   |
| ASXC160601CA                            | Amana® brand <u>S</u> plit <u>X</u> <u>C</u> ommunicating condensing units, 16 Seer R410A condensing unitS, converting to 7 mm coils.   |
| ASXC18**1AA                             | Amana® brand <u>S</u> plit <u>X</u> <u>C</u> ommunicating condensing units, 18 Seer R410A condensing units. Introduces Amana® brand 2-stage 16 SEER condensing units with R-410A, communicating models.   |
| ASXC180[36, 48, 60]1AB                  | Amana® brand <u>S</u> plit <u>X</u> <u>C</u> ommunicating condensing units, 18 Seer R410A condensing units. New revision updates wiring diagram with notes.   |
| ASXC180361AC<br>ASXC180[48-60]1AC       | Amana® brand <u>S</u> plit <u>X</u> <u>C</u> ommunicating condensing units, 18 Seer R410A condensing units. New revision replaces existing compressor ZPS20K4EPFV230 to ZPS20K5EPFV130 & existing compressor ZPS30K4EPFV230 to ZPS30K5EPFV130.  |
| ASXC180[48-60]1AC                       | Amana® brand <u>S</u> plit <u>X</u> <u>C</u> ommunicating condensing units, 18 Seer R410A condensing units. Introduces Ultratech® 2.0 compressor changes.   |

# PRODUCT IDENTIFICATION

| Single Piece Air Handlers   |  |
|---|--|
| Model #   | Description  |
| ACNF****1AA   | <u>A</u> Single Piece Air Handler <u>C</u> eiling Mount <u>N</u> Uncased <u>F</u> lowrater. Revision release all models of 13 SEER Dayton uncased air handlers.  |
| ACNF****16AA  | <u>A</u> Single Piece Air Handler <u>C</u> eiling Mount <u>N</u> Uncased <u>F</u> lowrater. Revision release all models of 13 SEER Dayton uncased air handlers.All Models will be suitable for use w/R-22 & R-410A   |
| ACNF****1AB   | <u>A</u> Single Piece Air Handler <u>C</u> eiling Mount <u>N</u> Uncased <u>F</u> lowrater. Drain pan material change.   |
| ACNF****1BA   | <u>A</u> Single Piece Air Handler <u>C</u> eiling Mount <u>N</u> Uncased <u>F</u> lowrater. Revision replaces current wavy fin design with new louvered fin design   |
| ACNF****16DA  | <u>A</u> Single Piece Air Handler <u>C</u> eiling Mount <u>N</u> Uncased <u>F</u> lowrater. Conversion of existing copper coils, manifolds, hairpins, flowrators, 90° flowrator stub to aluminum. Conversion of copper 3/8" return bends to aluminum 5/16" return bends. All Models will be suitable for use with R-22 and R-410A. |
| ACNF180[51-81]6DB<br>ACNF240[51-81]6DB<br>ACNF241016DB<br>ACNF300[51-81]6DB<br>ACNF301016DB | <u>A</u> Single Piece Air Handler <u>C</u> eiling Mount <u>N</u> Uncased <u>F</u> lowrater. Revision change for the UL1995 heater changes.   |
| ADPF****16AA  | <u>A</u> Single Piece <u>D</u> ownflow PSC Motor <u>U</u> nainted <u>F</u> lowrater. Introduction of new 13 SEER Air Handler Models. All Models will be suitable for use with R-22 and R-410A.   |
| ADPF364216AB  | <u>A</u> Single Piece <u>D</u> ownflow PSC Motor <u>U</u> nainted <u>F</u> lowrater. Revision replaces the current spot welded blower housing with the same cinched or crimped design used on the 80% furnace line.  |
| ADPF486016AB  | <u>A</u> Single Piece <u>D</u> ownflow PSC Motor <u>U</u> nainted <u>F</u> lowrater. Revision replaces the current spot welded blower housing with the same cinched or crimped design used on the 80% furnace line.  |
| ADPF304216AC  | <u>A</u> Single Piece <u>D</u> ownflow PSC Motor <u>U</u> nainted <u>F</u> lowrater. Revision replaces the current spot welded blower housing with the same cinched or crimped design used on the 80% furnace line.  |
| ADPF****1BA   | <u>A</u> Single Piece <u>D</u> ownflow PSC Motor <u>U</u> nainted <u>F</u> lowrater Revision replaces all ARPFcoils using way fin with louver enhanced fin.  |
| ADPF182416CA<br>ADPF486016CA  | <u>A</u> Single Piece <u>D</u> ownflow PSC Motor <u>U</u> nainted <u>F</u> lowrater. Revision replaces existing air handler copper coils and other associated parts with aluminum components.  |
| AEPF****16AA  | <u>A</u> Single Piece <u>E</u> Multi-Position Variable-Speed <u>P</u> ainted <u>F</u> lowrator. Introduction of new 13 SEER Air Handler Models. All Models will be suitable for use with R-22 and R-410A   |
| AEPF****16BA  | <u>A</u> Single Piece <u>E</u> Multi-Position Variable-Speed <u>P</u> ainted <u>F</u> lowrator. Revision introduces new models adding lower kw hit kits on the S&R plate   |
| AEPF****16BB  | <u>A</u> Single Piece <u>E</u> Multi-Position Variable-Speed <u>P</u> ainted <u>F</u> lowrator. Revision replaces the current spot welded blower housing with the same cinched or crimped design used on the 80% furnace line.   |
| AEPF****16CA  | <u>A</u> Single Piece <u>E</u> Multi-Position Variable-Speed <u>P</u> ainted <u>F</u> lowrator. Revision replaces all ARPFcoils using way fin with louver enhanced fin.  |
| AEPF****1BA   | <u>A</u> Single Piece <u>E</u> Multi-Position Variable-Speed <u>P</u> ainted <u>F</u> lowrator Introduction of R-22 Only Air Handlers.   |
| AEPF313716AA<br>ASPF313716AA  | <u>A</u> Single Piece <u>E</u> Multi-Position Variable-Speed <u>P</u> ainted <u>F</u> lowrator ( <b>AEPF</b> ) and <u>A</u> Single Piece <u>S</u> Multi-Position EEM motor <u>P</u> ainted <u>F</u> lowrator ( <b>ASPF</b> ). Introduction of 3-Ton Air Handler units with 3-row coil.   |

# PRODUCT IDENTIFICATION

| Single Piece Air Handlers  |   |
|--|---|
| Model #  | Description   |
| ARUF172916AA<br>A24-00-2RCA  | <u>A</u> Single Piece <u>R</u> Multi-Position PSC Motor <u>Un</u> Painted <u>F</u> lowrater Introduction of new Air Handler Models with all aluminum evaporator coils. Conversion includes coils, manifold, hairpin, flowrators, 3/8" return bend to 5/16" aluminum return bends. |
| ARUF****16AA   | <u>A</u> Single Piece <u>R</u> Multi-Position PSC Motor <u>Un</u> Painted <u>F</u> lowrater Introduction of new 13 SEER Air Handler Models. All Models will be suitable for use with R-22 and R-410A  |
| ARUF364216AB   | <u>A</u> Single Piece <u>R</u> Multi-Position PSC Motor <u>Un</u> Painted <u>F</u> lowrater.Revision replaces the current spot welded blower housing with the same cinched or crimped design used on the 80% furnace line.  |
| ARUF486016AB   | <u>A</u> Single Piece <u>R</u> Multi-Position PSC Motor <u>Un</u> Painted <u>F</u> lowrater.Revision replaces the current spot welded blower housing with the same cinched or crimped design used on the 80% furnace line.  |
| ARUF364216AC   | <u>A</u> Single Piece <u>R</u> Multi-Position PSC Motor <u>Un</u> Painted <u>F</u> lowrater.Revision replaces the current spot welded blower housing with the same cinched or crimped design used on the 80% furnace line.  |
| ARUF****16BA   | <u>A</u> Single Piece <u>R</u> Multi-Position PSC Motor <u>Un</u> Painted <u>F</u> lowrater. Revision replaces all ARUFcoils using way fin with louver enhanced fin.  |
| ARUF****1BA  | <u>A</u> Single Piece <u>R</u> Multi-Position PSC Motor <u>Un</u> Painted <u>F</u> lowrater Introduction of R-22 Only Air Handlers.   |
| ARUF****16CA   | <u>A</u> Single Piece <u>R</u> Multi-Position PSC Motor <u>Un</u> Painted <u>F</u> lowrater. Revision replaces existing air handler copper coils and other associated parts with aluminum components.   |
| ARUF***14AA  | <u>A</u> Single Piece <u>R</u> Multi-Position PSC Motor <u>Un</u> Painted <u>F</u> lowrator, R-410A only. Initial release of the redesigned air handlers.   |
| ARUF***14AA<br>ARUF***14AB   | <u>A</u> Single Piece <u>R</u> Multi-Position PSC Motor <u>Un</u> Painted <u>F</u> lowrator, R-410A only. Initial release of the redesigned air handlers manufactured at the Houston furnace facility.  |
| ARUF18B14AB<br>ARUF24B14BA<br>ARUF36C14BA<br>ARUF42C14AB                     | <u>A</u> Single Piece <u>R</u> Multi-Position PSC Motor <u>Un</u> Painted <u>F</u> lowrator, R-410A only. 2 & 3 ton coil replacement. 2 ton replaced w/3 row/16" tall; 3 ton replaced with 18" tall coil. 3.5 ton model blower motor changes from 10X8 to 10X10.                  |
| ARUF24B14BB  | <u>A</u> Single Piece <u>R</u> Multi-Position PSC Motor <u>Un</u> Painted <u>F</u> lowrator, R-410A only. Changing 16 Tall, 3 Row, 6 Cir Coil Assembly to 14 Tall, 3 Row, 6 Cir Coil Assembly.  |
| ARUF24B14CA  | <u>A</u> Single Piece <u>R</u> Multi-Position PSC Motor <u>Un</u> Painted <u>F</u> lowrator, R-410A only. Release ARUF24B14 CA model to meet AHRI requirements  |
| ARUF30C14BA  | <u>A</u> Single Piece <u>R</u> Multi-Position PSC Motor <u>Un</u> Painted <u>F</u> lowrator, R-410A only. Converts the existing ARUF30B, 17.5 inch wide models to an ARUF30C, 21 inch wide model.   |
| ARUF36C14BB<br>ARUF42C14AC   | <u>A</u> Single Piece <u>R</u> Multi-Position PSC Motor <u>Un</u> Painted <u>F</u> lowrator, R-410A only. The aluminum models changes the RBs, COs, and coil slabs to 9mm braze joints.   |
| ARUF36C14BC<br>ARUF30B14AC<br>ARUF30C14BB<br>ARUF42C14AD<br>ARUF[48-60]D14AC | <u>A</u> Single Piece <u>R</u> Multi-Position PSC Motor <u>Un</u> Painted <u>F</u> lowrator, R-410A only. Revisions are made due to changes made on serial plate.   |
| ARPF364216AB   | <u>A</u> Single Piece <u>R</u> Multi-Position PSC Motor <u>P</u> ainted <u>F</u> lowrater. Revision replaces the current spot welded blower housing with the same cinched or crimped design used on the 80% furnace line.   |
| ARPF486016AB   | <u>A</u> Single Piece <u>R</u> Multi-Position PSC Motor <u>P</u> ainted <u>F</u> lowrater. Revision replaces the current spot welded blower housing with the same cinched or crimped design used on the 80% furnace line.   |
| ARPF****16BA   | <u>A</u> Single Piece <u>R</u> Multi-Position PSC Motor <u>P</u> ainted <u>F</u> lowrater. Revision replaces all ARPFcoils using way fin with louver enhanced fin.  |
| ARPF****1BA  | <u>A</u> Single Piece <u>R</u> Multi-Position PSC Motor <u>P</u> ainted <u>F</u> lowrater. Introduction of R-22 Only Air Handlers.  |
| ARPF****16CA   | <u>A</u> Single Piece <u>R</u> Multi-Position PSC Motor <u>P</u> ainted <u>F</u> lowrater. Revision replaces existing air handler copper coils and other associated parts with aluminum components.   |
| ARPT***14AA  | <u>A</u> Single Piece <u>R</u> Multi-Position PSC Motor <u>P</u> ainted <u>F</u> lowrator, TXV, R-410A only. Initial release of the new air handlers.   |
| ARPT***14AB  | <u>A</u> Single Piece <u>R</u> Multi-Position PSC Motor <u>P</u> ainted <u>F</u> lowrator, TXV, R-410A only. Initial release of the air handlers manufactured at the Houston furnace facility.  |
| ARPT[18-36]B14AC<br>ARPT[36-60]D14AC   | <u>A</u> Single Piece <u>R</u> Multi-Position PSC Motor <u>P</u> ainted <u>F</u> lowrator, TXV, R-410A only. Revisions are made due to changes made on serial plate.  |

# PRODUCT IDENTIFICATION

| Single Piece Air Handlers                      |  |
|--|--|
| Model #  | Description  |
| ASPF****16AA                                   | <u>A</u> Single Piece <u>S</u> Multi-Position EEM motor <u>P</u> ainted <u>F</u> lowrator. Introduces new ASPF Air Handlers  |
| ASPF****16BA                                   | <u>A</u> Single Piece <u>S</u> Multi-Position EEM motor <u>P</u> ainted <u>F</u> lowrator. Revision introduces modified ASPF control scheme, to ensure blower operation during and after call for heat on units with heat kits and replacing wavy fin with louver enhanced fin on coil   |
| ASPF****16CA                                   | <u>A</u> Single Piece <u>S</u> Multi-Position EEM motor <u>P</u> ainted <u>F</u> lowrator. Revision replaces existing air handler copper coils and other associated parts with aluminum components.  |
| ASPF****16DA                                   | <u>A</u> Single Piece <u>S</u> Multi-Position EEM motor <u>P</u> ainted <u>F</u> lowrator. Revision introduces and replaces Regal-Beliot X-13 motor with Emerson SelecTech motor.  |
| ASPF****16EA                                   | <u>A</u> Single Piece <u>S</u> Multi-Position EEM motor <u>P</u> ainted <u>F</u> lowrator. Revision replaces existing air handler copper coils and other associated parts with aluminum components and replaces Regal-Beliot X-13 motor with Emerson SelecTech motor.  |
| ASPT[24/36/48/60]*14                           | <u>A</u> Single Piece <u>S</u> Multi-Position EEM motor <u>P</u> ainted txv. Revision introduces new generation ASPT air handlers.   |
| ASPT36C14AB<br>ASPT[48/60]D14AB<br>ASPT48D14AC | <u>A</u> Single Piece <u>S</u> Multi-Position EEM motor <u>P</u> ainted txv. Revision updates 9mm return bend coil changes to the new generation of ASPT air handlers. These revisions cover the ASPT36C, ASPT48D, and ASPT60D models.   |
| ASPT24B14AC<br>ASPT30C14AB<br>ASPT36C14AC      | <u>A</u> Single Piece <u>S</u> Multi-Position EEM motor <u>P</u> ainted txv. Programmed Broad Ocean Motor. This revision will allow the supplier to program the motor instead of furnace plant, thus eliminating any programming installing issues. The programmed label will be provided by supplier.   |
| ASPT[42-48]C14AA                               | <u>A</u> Single Piece <u>S</u> Multi-Position EEM motor <u>P</u> ainted txv. Introduction with 2+2coil slab assy. These models are required to meet higher tonnage ratings in Cabinet.   |
| ASPT42D14AB<br>ASPT48D14AD<br>ASPT60D14AC      | <u>A</u> Single Piece <u>S</u> Multi-Position EEM motor <u>P</u> ainted txv. Nidec Pre-programmed Motor. This revision will allow the Nidec motor to be programmed by the supplier instead of programming at the furnace plant, thus eliminating any programming installing issues.  |
| ASUF29B14AA<br>ASUF39C14AA                     | <u>A</u> Single Piece Air Handler <u>S</u> Energy Efficient Motor <u>U</u> nainted <u>F</u> lowrator. Releases ASUF29B14 and ASUF39C14 to add to the mid efficiency ranges that the product line offers. Incorporates the smart frame chassis with EEM (X-13) style motors and piston type flowrators.   |
| ASUF49C14AA<br>ASUF59D14AA                     | <u>A</u> Single Piece Air Handler <u>S</u> Energy Efficient Motor <u>U</u> nainted <u>F</u> lowrator. Introduces a mid-range efficiency air handler with X-13 motor & fixed orifice flowrator.   |
| ASUF49C14AB<br>ASUF59D14AB                     | <u>A</u> Single Piece Air Handler <u>S</u> Energy Efficient Motor <u>U</u> nainted <u>F</u> lowrator. Revision updates the 9mm return bends in the coil tubing assembly on the ASUF air handlers. These revisions cover the ASUF49C14 and ASUF59D14.   |
| ASUF59D14AC                                    | <u>A</u> Single Piece Air Handler <u>S</u> Energy Efficient Motor <u>U</u> nainted <u>F</u> lowrator. This revision creates a four row, piston, 9 mm return bend coil, which will create a new S&R plates and Travel label. It will also reduce poron gasket qty (pt # 0154A00005) from 10 ft to 7 ft similar to all other D chassis air handlers. |
| ASUF59D14AD                                    | <u>A</u> Single Piece Air Handler <u>S</u> Energy Efficient Motor <u>U</u> nainted <u>F</u> lowrator. Nidec Pre-programmed Motor. This revision will allow the Nidec motor to be programmed by the supplier instead of programming at the furnace plant, thus eliminating any programming installing issues.                                       |
| ASUF29B14AB<br>ASUF39C14AB<br>ASUF49C14AC      | <u>A</u> Single Piece Air Handler <u>S</u> Energy Efficient Motor <u>U</u> nainted <u>F</u> lowrator. Programmed Broad Ocean Motor. This revision will allow the supplier to program the motor instead of furnace plant, thus eliminating any programming installing issues. The programmed label will be provided by supplier.                    |

# PRODUCT IDENTIFICATION

| Single Piece Air Handlers  |   |
|--|---|
| Model #  | Description   |
| AVPTC183014AA<br>AVPTC313714AA<br>AVPTC426014AA  | <u>A</u> Single Piece <u>V</u> Multi-Position Variable-Speed <u>P</u> ainted <u>T</u> TXV <u>F</u> lowrator <u>C</u> ommunicating ready w/4-wires. Introduction of new 13 SEER Air Handler Models with the new communicating control & serial communicating indoor blower motor.                                |
| AVPTC24B14AA<br>AVPTC30C14AA<br>AVPTC36C14AA<br>AVPTC42D14AA<br>AVPTC48D14AA<br>AVPTC60D14AA | <u>A</u> Single Piece <u>V</u> Multi-Position Variable-Speed <u>P</u> ainted <u>T</u> TXV <u>F</u> lowrator <u>C</u> ommunicating ready w/4-wires. Redesign of the current AVPTC models to new air handler cabinetry incorporating the new 4-way, multi-position painted body utilized on the ARPT/ASPT models. |
| AVPTC48C14AA   | <u>A</u> Single Piece <u>V</u> Multi-Position Variable-Speed <u>P</u> ainted <u>T</u> TXV <u>F</u> lowrator <u>C</u> ommunicating ready w/4-wires. Minor revision change to S&R labels and Travel labels.   |
| AVPTC42D14AB<br>AVPTC48D14AB<br>AVPTC60D14AB   | <u>A</u> Single Piece <u>V</u> Multi-Position Variable-Speed <u>P</u> ainted <u>T</u> TXV <u>F</u> lowrator <u>C</u> ommunicating ready w/4-wires. Redesign of the current AVPTC models to new air handler cabinetry incorporating the new 4-way, multi-position painted body utilized on the ARPT/ASPT models. |
| AVPTC183014AB<br>AVPTC313714AB<br>AVPTC426014AB  | <u>A</u> Single Piece <u>V</u> Multi-Position Variable-Speed <u>P</u> ainted <u>T</u> TXV <u>F</u> lowrator <u>C</u> ommunicating ready w/4-wires. Introduces a new Communicating Air Handler Control Board (PCBJA103) which will be replacing the production PCBJA10.  |
| AVPTC60D14AC   | <u>A</u> Single Piece <u>V</u> Multi-Position Variable-Speed <u>P</u> ainted <u>T</u> TXV <u>F</u> lowrator <u>C</u> ommunicating ready w/4-wires. Revisions are made due to changes made on serial plate.  |
| AVPTC24B14AC<br>AVPTC30C14AB   | <u>A</u> Single Piece <u>V</u> Multi-Position Variable-Speed <u>P</u> ainted <u>T</u> TXV <u>F</u> lowrator <u>C</u> ommunicating ready w/4-wires. Revisions are made to update Heater kit airflow .  |

# PRODUCT IDENTIFICATION

| Single Piece Air Handlers  |  |
|--|--|
| Model #  | Description  |
| AWUF****16AA   | <u>A</u> Single Piece Air Handler <u>W</u> all Mount <u>U</u> nainted <u>F</u> lowrator. Introduces 13 SEER Dayton wall mount air handlers. All Models will be suitable for use with R-22 and R-410A |
| AWUF3005-101AA   | <u>A</u> Single Piece Air Handler <u>W</u> all Mount <u>U</u> nainted <u>F</u> lowrator. Introduces 13 SEER Dayton wall mount air handlers using a Burr Oak Louvered Fin coil.                       |
| AWUF****1BA  | <u>A</u> Single Piece Air Handler <u>W</u> all Mount <u>U</u> nainted <u>F</u> lowrator. Revision replaces current wavy fin design with new louvered fin design                                      |
| AWUF370**16AA  | <u>A</u> Single Piece Air Handler <u>W</u> all Mount <u>U</u> nainted Flowrator. Introduction of AWUF37 Air Handlers for use with R-22 and R410A.  |
| AWUF****16BA   | <u>A</u> Single Piece Air Handler <u>C</u> eiling Mount <u>N</u> Uncased <u>F</u> lowrater. Revision has louver fins & replaces copper tube hairpins with aluminum hairpins.                         |
| AWUF180316BA<br>AWUF240316BA<br>AWUF300316BA   | <u>A</u> Single Piece Air Handler <u>W</u> all Mount <u>U</u> nainted <u>F</u> lowrator. AWUF 3KW Heater Introduction. Introduction of 3KW heater in the AWUF air handlers                           |
| AWUF310516AA<br>AWUF310816AA<br>AWUF321016AA   | <u>A</u> Single Piece Air Handler <u>W</u> all Mount <u>U</u> nainted <u>F</u> lowrator. Introduction of higher 14 SEER AWUF series air-handlers   |
| AWUF300316BB<br>AWUF300516BB<br>AWUF300816BB<br>AWUF301016BB<br>AWUF360516BB<br>AWUF360816BB<br>AWUF361016BB   | <u>A</u> Single Piece Air Handler <u>W</u> all Mount <u>U</u> nainted <u>F</u> lowrator. The AWUF30/36 are currently 16x20x1. This revision uses 18x20x1 filter.                                     |
| AWUF18F(31,51,81)6AA<br>AWUF24F(11,31,51,81)6AA<br>AWUF30F(11,51,81)6AA<br>AWUF31F(51,81)6AA<br>AWUF32F116AA<br>AWUF36F(11,51,81)6AA<br>AWUF37(11,51,81)6AA  | <u>A</u> Single Piece Air Handler <u>W</u> all Mount <u>U</u> nainted <u>F</u> lowrator. Adding a drain pan water sensor switch to all AWUF products.  |
| AWUF180[31, 51, 81]6BB<br>AWUF240[31,51,81,101]6BB<br>AWUF300[51,81,101]6BC<br>AWUF310[51, 81, 101]6AB<br>AWUF360[51, 81, 101]6BC<br>AWUF370[51, 81, 101]6BB | <u>A</u> Single Piece Air Handler <u>W</u> all Mount <u>U</u> nainted <u>F</u> lowrator. Revision change for the UL1995 heater changes.  |
| AWUF19**16A*<br>AWUF25**16A*   | <u>A</u> Single Piece Air Handler <u>W</u> all Mount <u>U</u> nainted <u>F</u> lowrator. Introduces 14 SEER Dayton wall mount air handlers.  |

# PRODUCT IDENTIFICATION

| MBR/MBE Air Handlers                               |   |
|--|---|
| Model #  | Description   |
| MBR****AA-1AA                                      | <u>M</u> odular <u>B</u> lower <u>R</u> Multi-Position PSC Motor. Introduces module blower with PSC blower motor.   |
| MBR****AA-1AB                                      | <u>M</u> odular <u>B</u> lower <u>R</u> Multi-Position PSC Motor. Quality improvement to use 0.75" Quiet Flex Insulation.   |
| MBE****AA-1AA                                      | <u>M</u> odular <u>B</u> lower <u>E</u> Multi-Position Variable-Speed. Introduces module blower with variable speed blower motor.   |
| MBE****AA-1BA                                      | <u>M</u> odular <u>B</u> lower <u>E</u> Multi-Position Variable-Speed. Revision introduces new models adding lower kw hit kits on the S&R plate   |
| MBVC1200AA1-AA<br>MBVC1600AA1-AA<br>MBVC2000AA1-AA | <u>M</u> odular <u>B</u> lower <u>V</u> Multi-Position Variable-Speed <u>C</u> ommunicating ready w/4-wires. Introduction of module blower with variable speed blower motor with the new communicating control & serial communicating indoor blower motor.  |
| MBVC1200AA1-AB<br>MBVC1600AA1-AB<br>MBVC2000AA1-AB | <u>M</u> odular <u>B</u> lower <u>V</u> Multi-Position Variable-Speed <u>C</u> ommunicating ready w/4-wires. Module blower with variable speed blower motor with communicating control & serial communicating indoor blower motor. Replaces existing Emerson motors (013M00111 & 013M00112)   |
| MBVC1200AA1-AC<br>MBVC1600AA1-AC<br>MBVC2000AA1-AC | <u>M</u> odular <u>B</u> lower <u>V</u> Multi-Position Variable-Speed <u>C</u> ommunicating ready w/4-wires. Module blower with variable speed blower motor with communicating control & serial communicating indoor blower motor. Quality improvement to use 0.75" Quiet Flex Insulation.  |
| MBVC1200AA1-AD<br>MBVC1600AA1-AD<br>MBVC2000AA1-AD | <u>M</u> odular <u>B</u> lower <u>V</u> Multi-Position Variable-Speed <u>C</u> ommunicating ready w/4-wires. Module blower with variable speed blower motor with communicating control & serial communicating indoor blower motor. Introduces a new Communicating Air Handler Control Board (PCBJA103) which will be replacing the production PCBJA101. |



# PRODUCT IDENTIFICATION

| Model #  | Description   |
|--|---|
| CAUF****6AA  | <u>C</u> Indoor Coil <u>A</u> Upflow/Downflow <u>U</u> ncased <u>F</u> lowrator. Introduces CAUF Dayton Upflow/Downflow coils.  |
| CAUF****6BA  | <u>C</u> Indoor Coil <u>A</u> Upflow/Downflow <u>U</u> ncased <u>F</u> lowrator. Revision releases Burr Oak Louvered Fin in place of the Wavy Fin currently in production.  |
| CAUF****6DA  | <u>C</u> Indoor Coil <u>A</u> Upflow/Downflow [ <u>P</u> ainted or <u>U</u> ncased] <u>F</u> lowrator. Revision replaces existing copper coils and other associated parts with aluminum components.   |
| CAUF****6DB  | <u>C</u> Indoor Coil <u>A</u> Upflow/Downflow [ <u>P</u> ainted or <u>U</u> ncased] <u>F</u> lowrator. Drain pan material change.   |
| CAPF****6AA  | <u>C</u> Indoor Coil <u>A</u> Upflow/Downflow <u>P</u> ainted <u>F</u> lowrator. Introduces CAPF Dayton Upflow/Downflow coils.  |
| CAPF****6BA  | <u>C</u> Indoor Coil <u>A</u> Upflow/Downflow <u>P</u> ainted <u>F</u> lowrator. Revision releases Burr Oak Louvered Fin in place of the Wavy Fin currently in production.  |
| CAPF/CAUF36***CA   | <u>C</u> Indoor Coil <u>A</u> Upflow/Downflow [ <u>P</u> ainted or <u>U</u> ncased] <u>F</u> lowrator. Revision redesigns for performance improvement from 2 row to 3 row.  |
| CAPF****6DA  | <u>C</u> Indoor Coil <u>A</u> Upflow/Downflow [ <u>P</u> ainted or <u>U</u> ncased] <u>F</u> lowrator. Revision replaces existing copper coils and other associated parts with aluminum components.   |
| CAPF****6DB  | <u>C</u> Indoor Coil <u>A</u> Upflow/Downflow [ <u>P</u> ainted or <u>U</u> ncased] <u>F</u> lowrator. Drain pan material change.   |
| CHPF****6AA  | <u>C</u> Indoor Coil <u>H</u> orizontal A Coil <u>P</u> ainted <u>F</u> lowrator. Release 13 SEER CHPF horizontal A coil.   |
| CHPF****6BA  | <u>C</u> Indoor Coil <u>H</u> orizontal A Coil <u>P</u> ainted <u>F</u> lowrator. Release 13 SEER CHPF horizontal A coil. Revision releases Burr Oak Louvered Fin in place of the Wavy Fin currently in production. The rows change by one, (i.e. 4 row to 3 row; 3 row to 2 row) where appli |
| CAPT3131B4BA<br>CAPT3131C4BA   | <u>C</u> Indoor Coil <u>A</u> Upflow/Downflow [ <u>P</u> ainted] <u>T</u> XV. Introduction of coils with factory installed, non adjustable TXV. Development of single stage AHRI ratings for CAPT3131 NTC combinations.   |
| CAPT3743C4AA<br>CAPT3743D4AA   | <u>C</u> Indoor Coil <u>A</u> Upflow/Downflow [ <u>P</u> ainted] <u>T</u> XV. Development of single stage AHRI ratings for CAPT3743, NTC combinations.  |
| CAPT4961C4AA<br>CAPT4961D4AA   | <u>C</u> Indoor Coil <u>A</u> Upflow/Downflow [ <u>P</u> ainted] <u>T</u> XV. Development of single stage AHRI ratings for CAPT4961C4, NTC combinations.  |
| CHPF1824A6CB<br>CHPF2430B6CB<br>CHPF3636B6CB<br>CHPF3642C6CB<br>CHPF3642D6CB<br>CHPF3743C6BB<br>CHPF3743D6BB<br>CHPF4860D6DB | <u>C</u> Indoor Coil <u>H</u> orizontal A Coil <u>P</u> ainted <u>F</u> lowrator. 13 SEER CHPF horizontal A coil. Drain pan material change.  |

# PRODUCT IDENTIFICATION

| Evaporator Coils   |   |
|--|---|
| Model #  | Description   |
| CSCF****6AA  | <u>C</u> Indoor Coil <u>S</u> Horizontal Slab Coil <u>C</u> Upainted <u>F</u> lowrator. Release 13 SEER CSCF slab horizontal coil.  |
| CSCF****6BA  | <u>C</u> Indoor Coil <u>S</u> Horizontal Slab Coil <u>C</u> Upainted <u>F</u> lowrator. Revision releases Burr Oak Louvered Fin in place of the Wavy Fin currently in production. The rows change by one, (i.e. 4 row to 3 row; 3 row to 2 row) where applicable. |
| CSCF1824N6BB<br>CSCF3036N6BB<br>CSCF3642N6CB<br>CSCF4860N6CB                                 | <u>C</u> Indoor Coil <u>S</u> Horizontal Slab Coil <u>C</u> Upainted <u>F</u> lowrator. Drain pan material change.  |
| CSCF1824N6CA<br>CSCF3036N6CA<br>CSCF3642N6CA<br>CSCF4860N6CA                                 | <u>C</u> Indoor Coil <u>S</u> Horizontal Slab Coil <u>C</u> Upainted <u>F</u> lowrator. Release 13 SEER CSCF slab horizontal coil. Converting copper coils, maifolds, haripins, flowrators to aluminum coils.   |
| CTPF****6AA  | <u>C</u> Indoor Coil <u>I</u> Coated <u>P</u> ainted <u>F</u> lowrator. Initial release of coated coils.  |
| CTPF1824*6AB<br>CTPF3030*6AB<br>CTPF3131*6AB<br>CTPF3636*6AC<br>CTPF3642*6AB<br>CTPF4860*6AB | <u>C</u> Indoor Coil <u>I</u> Coated <u>P</u> ainted <u>F</u> lowrator. Drain pan material change.  |
| CTUF1824*6AA<br>CTUF3030*6AA<br>CTUF3131*6AA<br>CTUF3636*6AA<br>CTUF3642*6AA<br>CTUF4860*6AA | <u>C</u> Indoor Coil <u>I</u> Coated <u>U</u> npainted <u>F</u> lowrator. Initial release.  |
| CTUF1824*6AB<br>CTUF3030*6AB<br>CTUF3131*6AB<br>CTUF3636*6AC<br>CTUF3642*6AB<br>CTUF4860*6AB | <u>C</u> Indoor Coil <u>I</u> Coated <u>U</u> npainted <u>F</u> lowrator. Initial release.  |

# PRODUCT IDENTIFICATION

**READY 2015**

| Ready 2015 Split System Heat Pumps R410A |   |
|--|---|
| Model #                                  | Description   |
| ANZ140[18-60]1AA                         | <u>A</u> mana® Brand <u>S</u> plit <u>Z</u> R410A 14 SEER heat pump units. Introduction of ready 15, 14 SEER heat pumps to meet the 2015 energy efficiency requirement. |
| ASZ140[18-60]1KA                         | <u>G</u> oodman <u>S</u> plit <u>Z</u> R410A 14 SEER Heat Pump units. Introduction of ready 15, 14 SEER heat pumps to meet the 2015 energy efficiency requirement.      |
| GSZ140[18-60]1KA<br>GSZ140491AA          | <u>G</u> oodman <u>S</u> plit <u>Z</u> R410A 14 SEER Heat Pump units. Ready 15 14 SEER heat pumps to meet the 2015 energy efficiency requirement.                       |
| VSZ14[018-060]1AA                        | <u>V</u> alue <u>S</u> plit <u>Z</u> heat pump, 14 Seer R410A heat pump units. Introduction of ready 15, 14 SEER heat pumps to meet the 2015 efficiency requirement.    |

| Ready 2015 Split System AC R410A |  |
|----------------------------------|--|
| Model #                          | Description  |
| ANX140431AA                      | <u>A</u> mana® Brand <u>S</u> plit <u>X</u> R410A 14 SEER air conditioning units. Introduction of ready 15, 12.2 EER Air conditioning units. |
| GSX140311AA                      | <u>G</u> oodman <u>S</u> plit <u>X</u> R410A 13 SEER Heat Pump units. Introduction of ready 15, 12.2 EER air conditioning units.             |

| Ready 2015 Single Piece Air Handlers   |  |
|--|--|
| Model #  | Description  |
| ARUF25B14AA<br>ARUF29B14AA<br>ARUF31B14AA<br>ARUF37C14AA<br>ARUF43C14AA<br>ARUF47D14AA<br>ARUF49C14AA<br>ARUF61D14AA | <u>A</u> Single Piece <u>R</u> Multi-Position PSC Motor <u>U</u> npainted <u>F</u> lowrater. Introduction of new ready 2015 Air Handler Models that meet the 2015 energy efficiency levels (for 7mm 14 SEER Heat Pumps). |
| ASPT61D14AA  | <u>A</u> Single Piece <u>S</u> Multi-Position EEM motor <u>P</u> ainted TXV. Introduction of new ready 2015 air handlers to meet energy efficiency levels (for 7mm 14 SEER 5.0 Ton Heat Pumps).                          |

# PRODUCT IDENTIFICATION

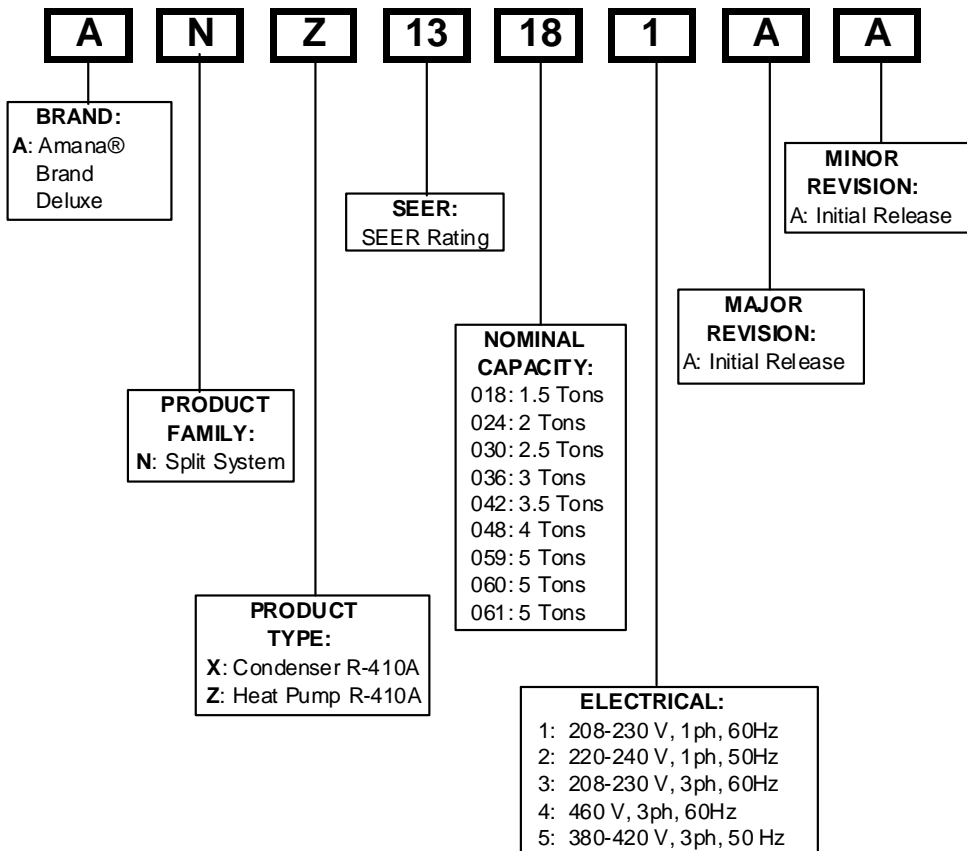
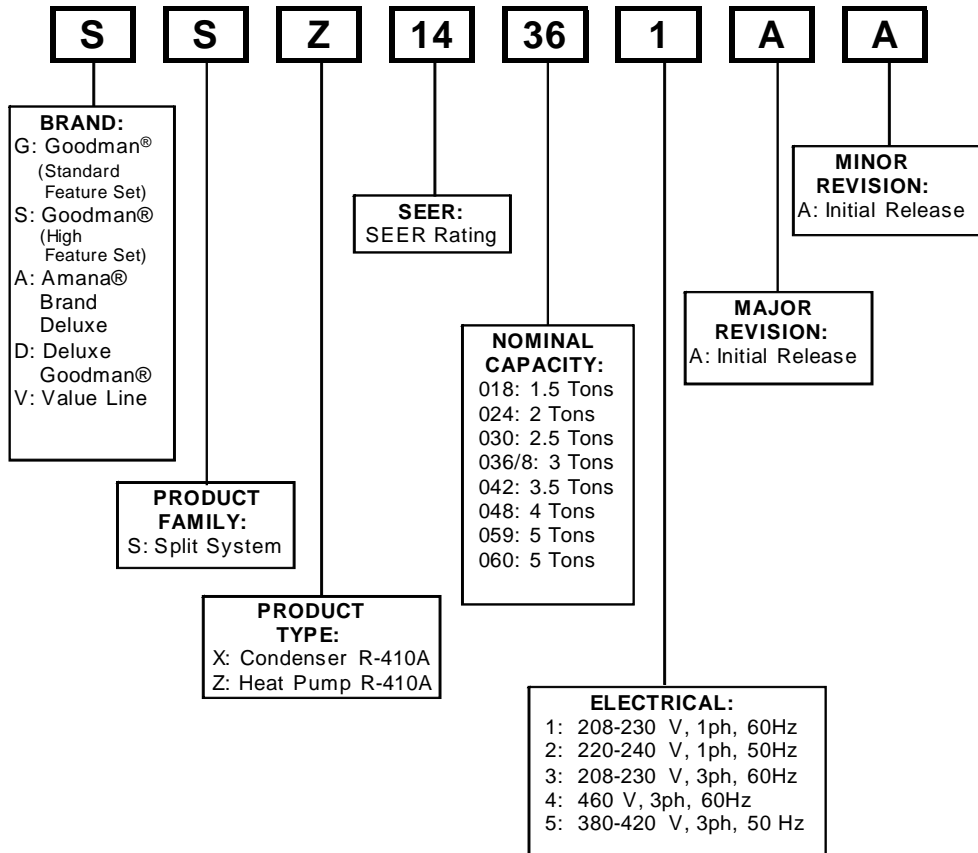

# PRODUCT IDENTIFICATION

ComfortNet™

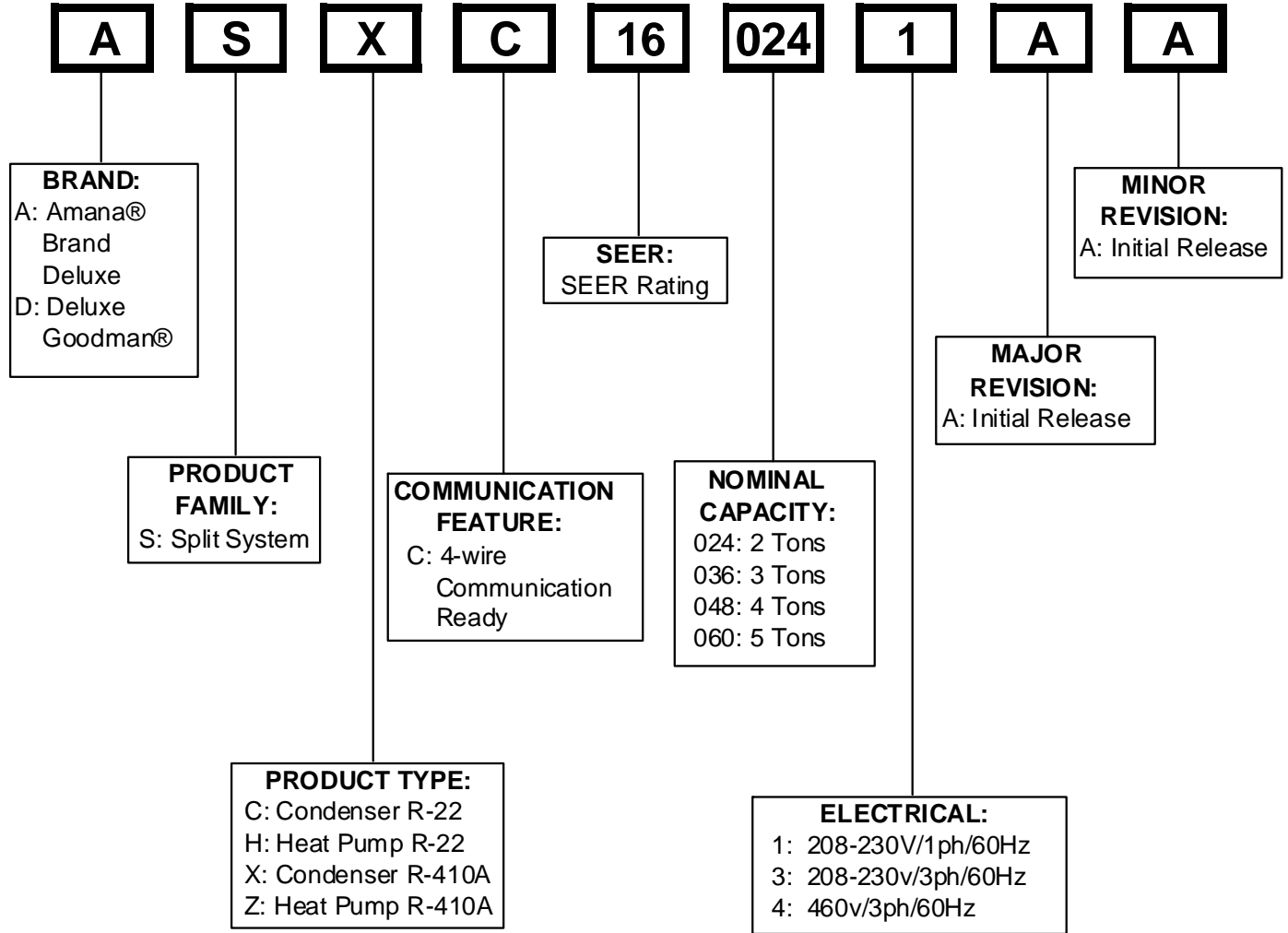

# PRODUCT IDENTIFICATION

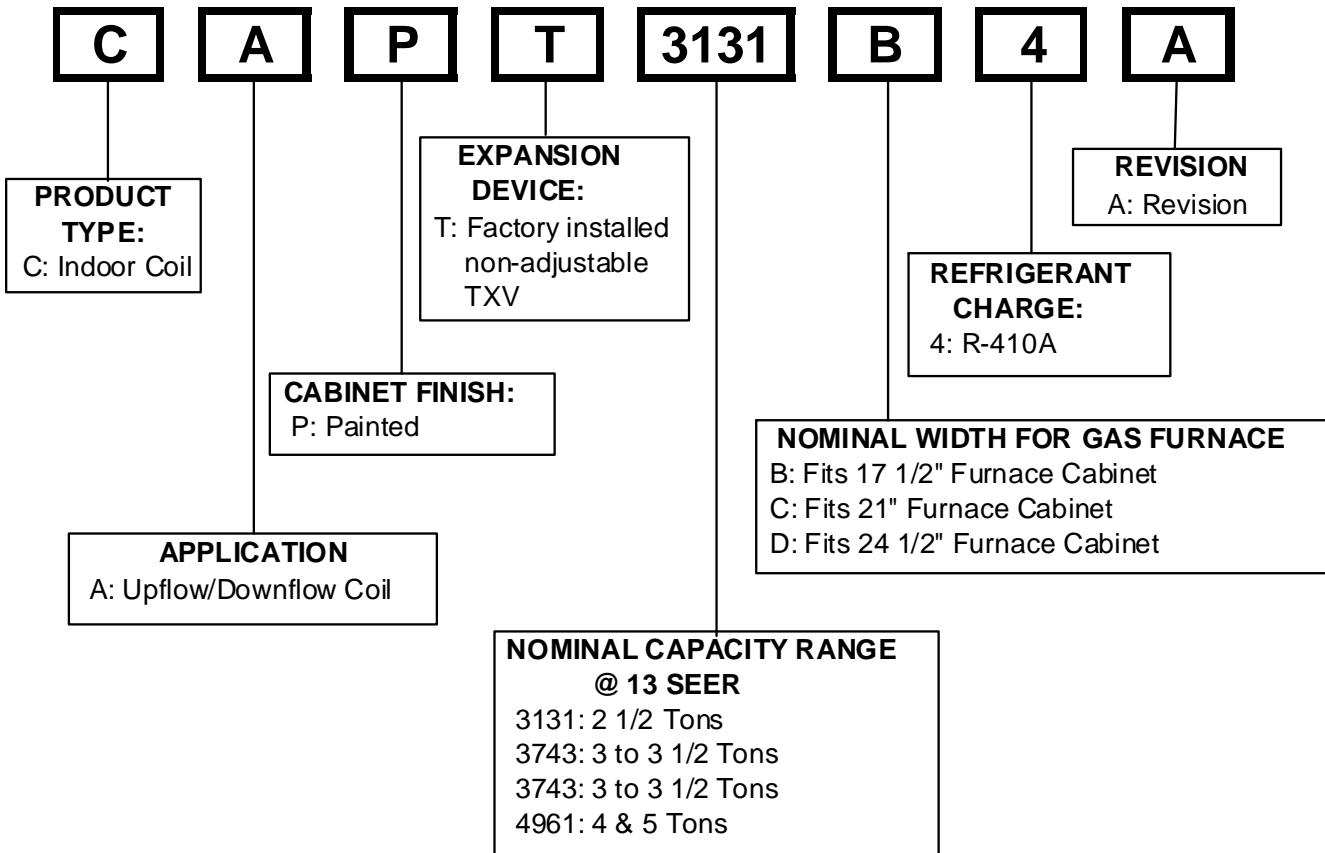
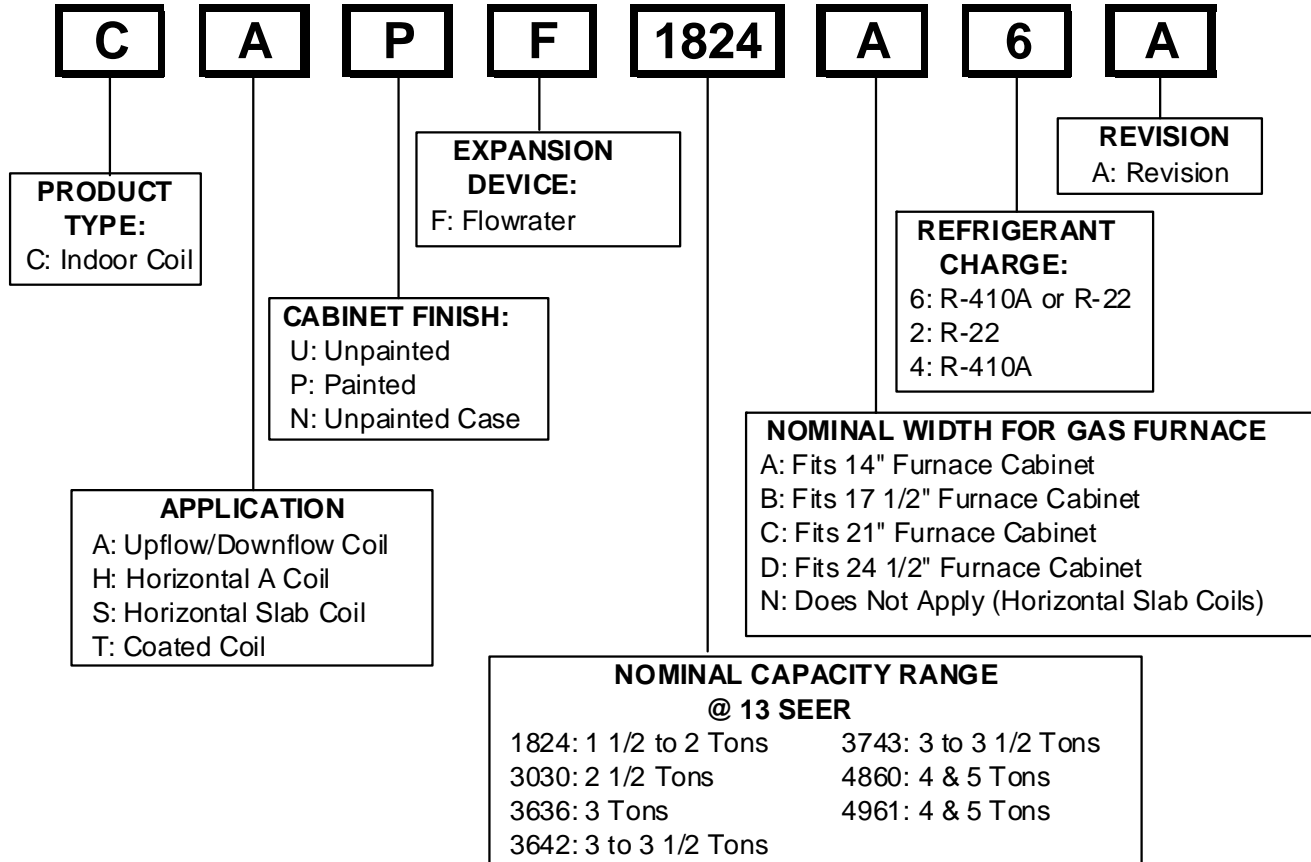

# PRODUCT IDENTIFICATION

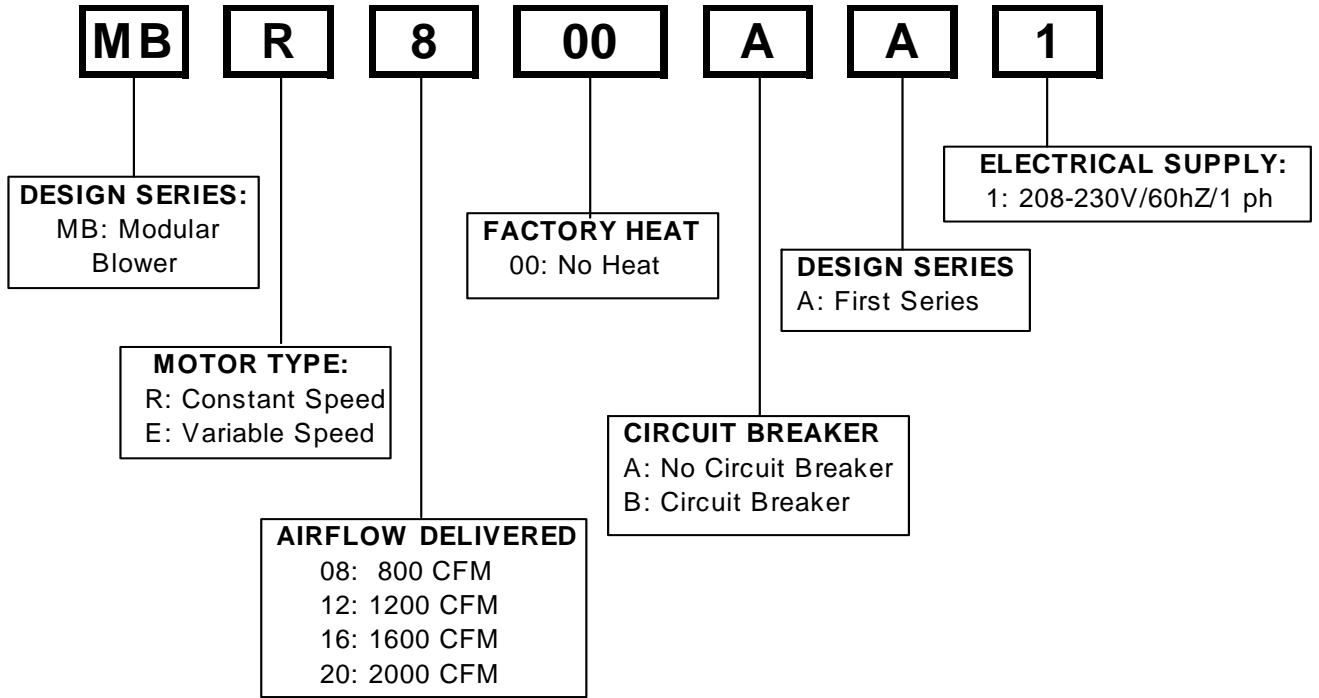

**ComfortNet™**

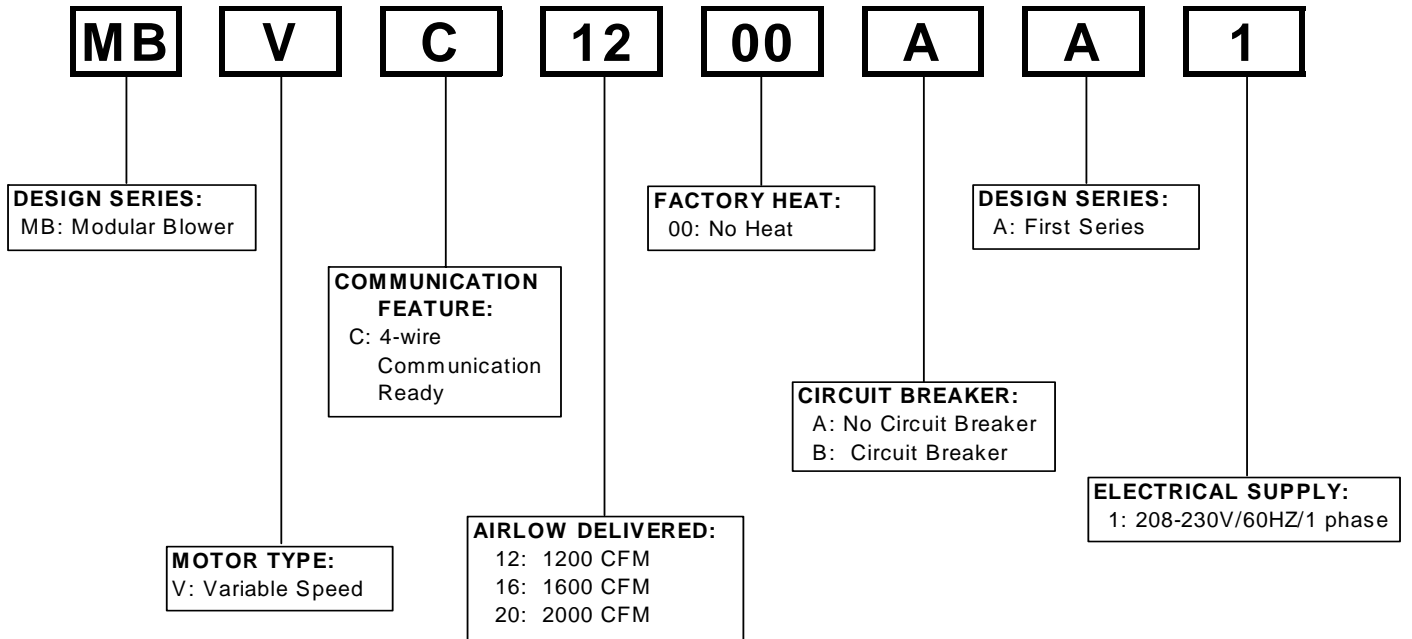

# PRODUCT IDENTIFICATION

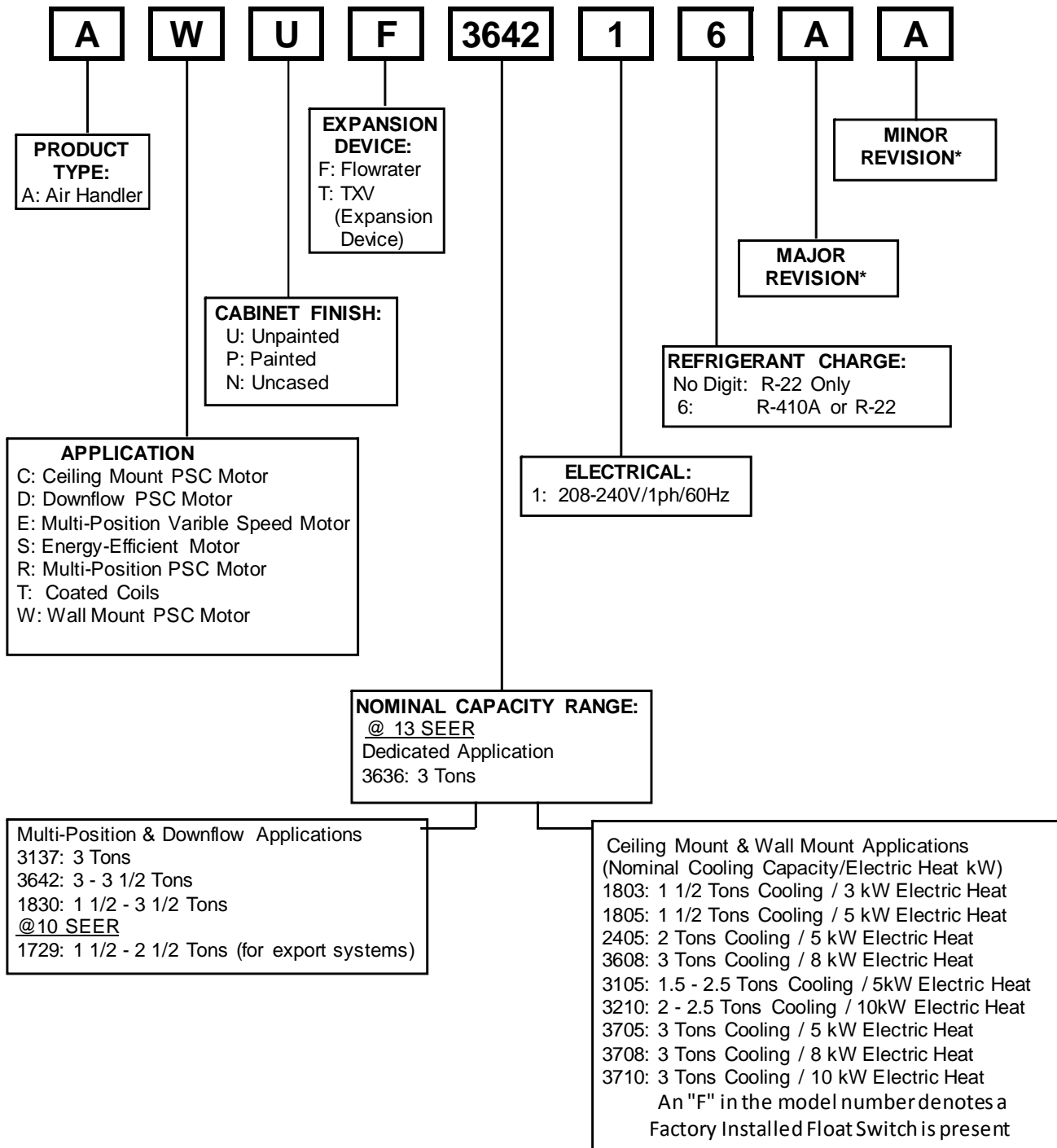

All Airhandlers use **DIRECT DRIVE MOTORS**. Power supply is AC 208-240v, 60 hz, 1 phase.



# PRODUCT IDENTIFICATION

ARUF\*\*14\*\* / ARPT\*\*14\*\* /  
ASPT\*\*14\*\*

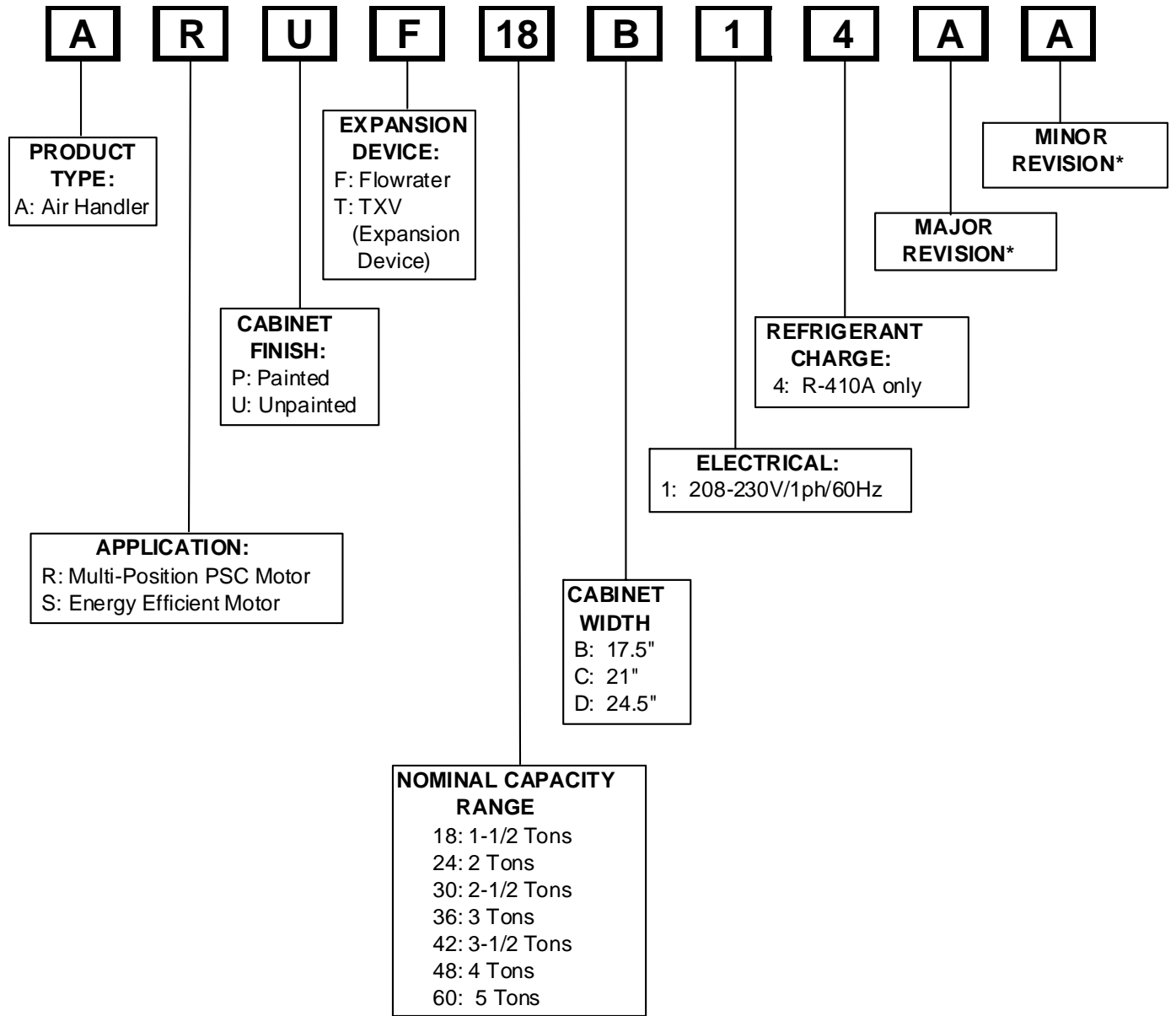

*Airhandlers use DIRECT DRIVE MOTORS. Power supply is AC 208-230v, 60 hz, 1 phase.*



# PRODUCT IDENTIFICATION

# LIGHT COMMERCIAL

| Split System Air Conditioners R410A - LIGHT COMMERCIAL   |  |
|--|--|
| Model #  | Description  |
| GSX11090*AA<br>GSX11120*AA                               | <u>G</u> oodman <u>S</u> plit <u>X</u> Condenser 11 Seer condensing units. Introduction of Goodman Light Commercial 11 SEER, R-410A Condensers.                              |
| GSX111203AB<br>GSX110903AB<br>GSX111204AB<br>GSX110904AB | <u>G</u> oodman <u>S</u> plit <u>X</u> Condenser 11 Seer, 208-230V and 460V 3 Phase condensing units with new ball valve/brackets, suction tube/assembly and panel w/offset. |

| Split System Heat Pumps R410A - LIGHT COMMERCIAL         |   |
|--|---|
| Model #  | Description   |
| GSZ11090*AA<br>GSZ11120*AA                               | <u>G</u> oodman <u>S</u> plit <u>Z</u> R410A Heat Pump 11 Seer R410A heat pump units. Introduction of Goodman Light Commercial 11 SEER, R-410A Heat Pumps.                              |
| GSZ110903AB<br>GSZ111203AB<br>GSZ110904AB<br>GSZ111204AB | <u>G</u> oodman <u>S</u> plit <u>Z</u> R410A Heat Pump 11 Seer, 208-230V and 460V 3 Phase R410A heat pump units with new ball valve/brackets, suction tube/assembly and panel w/offset. |

| Single Piece Air Handlers - LIGHT COMMERCIAL |   |
|--|---|
| Model #                                      | Description   |
| AR0904A<br>AR1204A                           | <u>A</u> Single Piece <u>R</u> Multi-Position PSC Motor. Introduction of new 7.5 & 10 Ton Air Handler Models, for use with GSX11 and GSZ11 Light Commercial Models. |

# PRODUCT IDENTIFICATION

# LIGHT COMMERCIAL

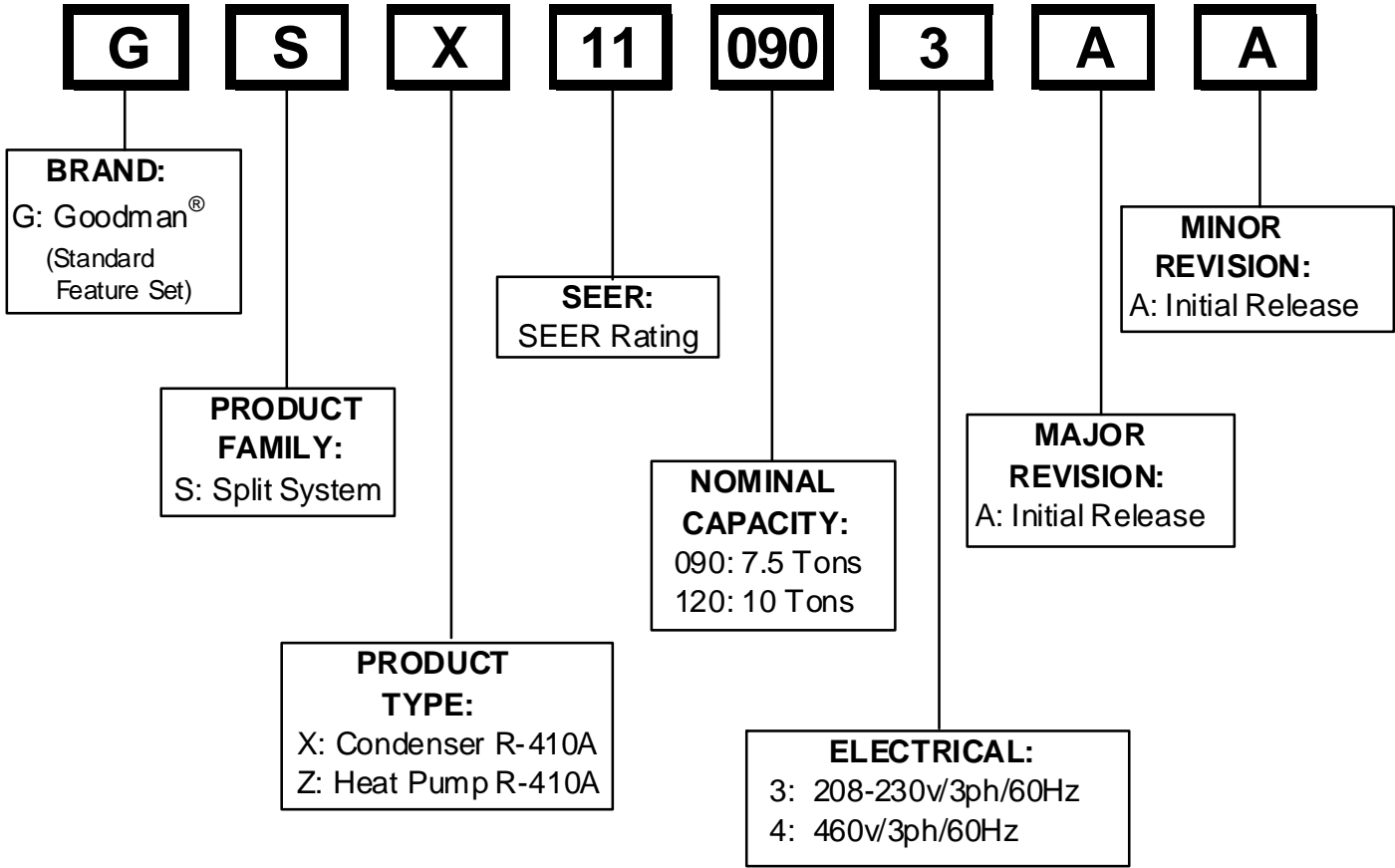

GSX110903AA  
 GSX110904AA  
 GSX111203AA  
 GSX111204AA

GSZ110903AA  
 GSZ110904AA  
 GSZ111203AA  
 GSZ111204AA

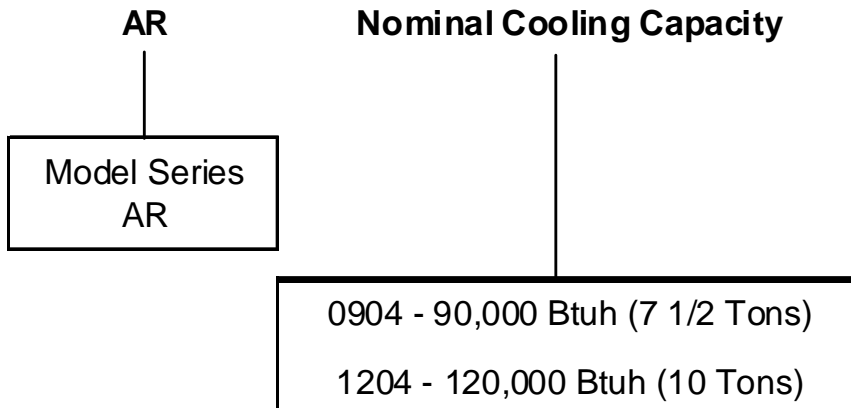

*For use with GSX/GSZ11 Light Commercial models only.*

# ACCESSORIES

# LIGHT COMMERCIAL

## GSX11

| Model   | Description              | GSX110903 | GSX110904 | GSX111203 | GSX111204 |
|---------|--------------------------|-----------|-----------|-----------|-----------|
| FSK01A* | Freeze Protection Kit    | x         | x         | x         | x         |
| ASC01   | Anti Short Cycle Kit     | x         | x         | x         | x         |
| LAKT-01 | Low Ambient Kit          | x         | x         | x         | x         |
| LSK03*  | Liquid Line Solenoid Kit | x         | x         | x         | x         |

## GSZ11

| Model       | Description              | GSZ110903 | GSZ110904 | GSZ111203 | GSZ111204 |
|-------------|--------------------------|-----------|-----------|-----------|-----------|
| FSK01A*     | Freeze Protection Kit    | x         | x         | x         | x         |
| ASC01       | Anti Short Cycle Kit     | x         | x         | x         | x         |
| OT-EHR18-60 | Emergency Heat Relay Kit | ---       | ---       | ---       | ---       |
| LAKT-01     | Low Ambient Kit          | x         | x         | x         | x         |
| LSK03*      | Liquid Line Solenoid Kit | x         | x         | x         | x         |

# ELECTRIC HEATER KITS

| AHKD Model | Nominal kW | Electrical Characteristics | Stages | Weight (lbs.) | Max. Overcurrent Protection |
|------------|------------|----------------------------|--------|---------------|-----------------------------|
| AHKD15-3   | 15         | 208-230/3/60               | 1      | 56            | 60                          |
| AHKD15-4   | 15         | 460/3/60                   | 1      | 55            | 30                          |
| AHKD20-3   | 20         | 208-230/3/60               | 2      | 59            | 70                          |
| AHKD20-4   | 20         | 460/3/60                   | 2      | 57            | 35                          |
| AHKD30-3   | 30         | 208-230/3/60               | 2      | 60            | 100                         |
| AHKD30-4   | 30         | 460/3/60                   | 2      | 58            | 50                          |

### NOTES:

- AR Series Air Handlers do not have factory installed electric heat. Purchased as an accessory, these are the **ONLY** heater kits that can be used with the AR Series.
- The electrical characteristics of the air handler, electric heater kits and building power supply must be compatible.

# ACCESSORIES

## ASX13

| Model               | Description              | ASX13<br>018* | ASX13<br>024* | ASX13<br>030* | ASX13<br>036* | ASX13<br>042* | ASX13<br>048* | ASX13<br>060*/061* |
|---------------------|--------------------------|---------------|---------------|---------------|---------------|---------------|---------------|--------------------|
| ABK-20 <sup>1</sup> | Anchor Bracket Kit       | X             | X             | X             | X             | X             | X             | X                  |
| ASC01               | Anti-Short Cycle Kit     | X             | X             | X             | X             | X             | X             | X                  |
| CSR-U-1             | Hard-start Kit           | X             | X             | X             | X             |               |               |                    |
| CSR-U-2             | Hard-start Kit           |               |               |               | X             | X             |               |                    |
| CSR-U-3             | Hard-start Kit           |               |               |               |               |               | X             | X                  |
| FSK01A <sup>2</sup> | Freeze Protection Kit    | X             | X             | X             | X             | X             | X             | X                  |
| LSK02A              | Liquid Line Solenoid Kit | X             | X             | X             | X             | X             | X             | X                  |
| TX2N4A <sup>3</sup> | TXV Kit                  | X             | X             |               |               |               |               |                    |
| TX3N4 <sup>3</sup>  | TXV Kit                  |               |               | X             | X             |               |               |                    |
| TX5N4 <sup>3</sup>  | TXV Kit                  |               |               |               |               | X             | X             | X                  |

## G/VSX13

| Model               | Description              | G/VSX13<br>018* | G/VSX13<br>024* | G/VSX13<br>030* | G/VSX13<br>036* | G/VSX13<br>042* | G/VSX13<br>048* | G/VSX13060*<br>GSX13061* |
|---------------------|--------------------------|-----------------|-----------------|-----------------|-----------------|-----------------|-----------------|--------------------------|
| ABK-20 <sup>1</sup> | Anchor Bracket Kit       | X               | X               | X               | X               | X               | X               | X                        |
| ABK-21 <sup>4</sup> | Anchor Bracket Kit       | X               | X               | X               | X               |                 |                 |                          |
| ASC01               | Anti-Short Cycle Kit     | X               | X               | X               | X               | X               | X               | X                        |
| CSR-U-1             | Hard-start Kit           | X               | X               | X               | X               |                 |                 |                          |
| CSR-U-2             | Hard-start Kit           |                 |                 |                 | X               | X               |                 |                          |
| CSR-U-3             | Hard-start Kit           |                 |                 |                 |                 |                 | X               | X                        |
| FSK01A <sup>1</sup> | Freeze Protection Kit    | X               | X               | X               | X               | X               | X               | X                        |
| LSK02A              | Liquid Line Solenoid Kit | X               | X               | X               | X               | X               | X               | X                        |
| TX2N4A <sup>3</sup> | TXV Kit                  | X               | X               |                 |                 |                 |                 |                          |
| TX3N4 <sup>2</sup>  | TXV Kit                  |                 |                 | X               | X               |                 |                 |                          |
| TX5N4 <sup>2</sup>  | TXV Kit                  |                 |                 |                 |                 | X               | X               | X                        |
| CSB-15              | Sound Blanket Kit        |                 |                 |                 |                 | X               | X               | X                        |
| CSB-16              | Sound Blanket Kit        | X               | X               | X               | X               |                 |                 |                          |

## GSX13 Three-phase models

| Model               | Description              | GSX13<br>0363* | GSX13<br>0483* | GSX13<br>0484* | GSX130<br>[60/61]3* | GSX130<br>[60/61]4* |
|---------------------|--------------------------|----------------|----------------|----------------|---------------------|---------------------|
| ABK-20 <sup>1</sup> | Anchor Bracket Kit       | X              | X              | X              | X                   | X                   |
| ASC01               | Anti-Short Cycle Kit     | X              | X              | X              | X                   | X                   |
| FSK01A <sup>2</sup> | Freeze Protection Kit    | X              | X              | X              | X                   | X                   |
| LSK02A              | Liquid Line Solenoid Kit | X              | X              | X              | X                   | X                   |
| TX3N4 <sup>3</sup>  | TXV Kit                  | X              |                |                |                     |                     |
| TX5N4 <sup>3</sup>  | TXV Kit                  |                | X              | X              | X                   | X                   |
| CSB-15              | Sound Blanket Kit        |                | X              | X              | X                   | X                   |
| CSB-16              | Sound Blanket Kit        | X              |                |                |                     |                     |
| LAKT01              | Low Ambient Kit          | X              | X              | X              | X                   | X                   |
| 0163R00002          | Crankcase Heater Kit     | X              |                |                |                     |                     |
| 0163R00003          | Crankcase Heater Kit     |                | X              | X              |                     |                     |
| 0163R00004          | Crankcase Heater Kit     |                |                |                | X                   | X                   |

<sup>1</sup> Contains 20 brackets; four brackets needed to anchor unit to pad

<sup>2</sup> Installed on indoor coil.

<sup>3</sup> Field-installed, non-bleed, expansion valve kit - Condensing units and heat pumps with reciprocating compressors require the use of start-assist components when used in conjunction with an indoor coil using a non-bleed thermal expansion valve refrigerant.

<sup>4</sup> For use on the GSX13 & VSX13 23" chassis only. Contains 20 brackets; four brackets needed to anchor unit to pad.

# ACCESSORIES

## ASX14

| Model               | Description              | ASX14<br>018 | ASX14<br>024 | ASX14<br>030 | ASX14<br>036 | ASX14<br>042 | ASX14<br>048 | ASX14<br>060 |
|---------------------|--------------------------|--------------|--------------|--------------|--------------|--------------|--------------|--------------|
| ABK-20 <sup>1</sup> | Anchor Bracket Kit       | X            | X            | X            | X            | X            | X            | X            |
| ASC01               | Anti-Short Cycle Kit     | X            | X            | X            | X            | X            | X            | X            |
| CSR-U-1             | Hard-start Kit           | X            | X            | X            | X            |              |              |              |
| CSR-U-2             | Hard-start Kit           |              |              |              | X            | X            |              |              |
| CSR-U-3             | Hard-start Kit           |              |              |              |              |              | X            | X            |
| FSK01A <sup>1</sup> | Freeze Protection Kit    | X            | X            | X            | X            | X            | X            | X            |
| LSK02A              | Liquid Line Solenoid Kit | X            | X            | X            | X            | X            | X            | X            |
| TX2N4A              | TXV Kit                  | X            | X            |              |              |              |              |              |
| TX3N4               | TXV Kit                  |              |              | X            | X            |              |              |              |
| TX5N4               | TXV Kit                  |              |              |              |              | X            | X            | X            |

## GSX14

| Model               | Description              | GSX14<br>018 | GSX14<br>024 | GSX14<br>030 | GSX14<br>036 | GSX14<br>042 | GSX14<br>048 | GSX14<br>060 |
|---------------------|--------------------------|--------------|--------------|--------------|--------------|--------------|--------------|--------------|
| ABK-20 <sup>1</sup> | Anchor Bracket Kit       | X            | X            | X            | X            | X            | X            | X            |
| ASC01               | Anti-Short Cycle Kit     | X            | X            | X            | X            | X            | X            | X            |
| CSR-U-1             | Hard-start Kit           | X            | X            | X            | X            |              |              |              |
| CSR-U-2             | Hard-start Kit           |              |              |              | X            | X            |              |              |
| CSR-U-3             | Hard-start Kit           |              |              |              |              |              | X            | X            |
| FSK01A <sup>1</sup> | Freeze Protection Kit    | X            | X            | X            | X            | X            | X            | X            |
| LSK02A              | Liquid Line Solenoid Kit | X            | X            | X            | X            | X            | X            | X            |
| TX2N4A              | TXV Kit                  | X            | X            |              |              |              |              |              |
| TX3N4               | TXV Kit                  |              |              | X            | X            |              |              |              |
| TX5N4               | TXV Kit                  |              |              |              |              | X            | X            | X            |
| CSB-14              | Sound Blanket Kit        |              |              |              |              |              | X            | X            |
| CSB-16              | Sound Blanket Kit        | X            | X            | X            | X            | X            |              |              |

## SSX14

| Model               | Description              | SSX14<br>018 | SSX14<br>024 | SSX14<br>030 | SSX14<br>036 | SSX14<br>042 | SSX14<br>048 | SSX14<br>060 |
|---------------------|--------------------------|--------------|--------------|--------------|--------------|--------------|--------------|--------------|
| ABK-20 <sup>1</sup> | Anchor Bracket Kit       | X            | X            | X            | X            | X            | X            | X            |
| ASC01               | Anti-Short Cycle Kit     | X            | X            | X            | X            | X            | X            | X            |
| CSR-U-1             | Hard-start Kit           | X            | X            | X            | X            |              |              |              |
| CSR-U-2             | Hard-start Kit           |              |              |              | X            | X            |              |              |
| CSR-U-3             | Hard-start Kit           |              |              |              |              |              | X            | X            |
| FSK01A <sup>1</sup> | Freeze Protection Kit    | X            | X            | X            | X            | X            | X            | X            |
| LSK02A              | Liquid Line Solenoid Kit | X            | X            | X            | X            | X            | X            | X            |
| TX2N4A              | TXV Kit                  | X            | X            |              |              |              |              |              |
| TX3N4 <sup>2</sup>  | TXV Kit                  |              |              | X            | X            |              |              |              |
| TX5N4 <sup>2</sup>  | TXV Kit                  |              |              |              |              | X            | X            | X            |

<sup>1</sup> Installed on indoor coil

<sup>2</sup> Require for heat pump applications where ambient temperatures fall below 0°F with 50% or higher relative humidity.

# ACCESSORIES

## SSX16

| Model               | Description              | SSX16<br>024* | SSX16<br>030* | SSX16<br>036* | SSX16<br>042* | SSX16<br>048* | SSX16<br>060* |
|---------------------|--------------------------|---------------|---------------|---------------|---------------|---------------|---------------|
| ABK-20 <sup>1</sup> | Anchor Bracket Kit       | X             | X             | X             | X             | X             | X             |
| ASC01               | Anti-Short Cycle Kit     | X             | X             | X             | X             | X             | X             |
| CSR-U-1             | Hard-start Kit           | X             | X             | X             |               |               |               |
| CSR-U-2             | Hard-start Kit           |               |               | X             | X             |               |               |
| CSR-U-3             | Hard-start Kit           |               |               |               |               | X             | X             |
| FSK01A <sup>1</sup> | Freeze Protection Kit    | X             | X             | X             | X             | X             | X             |
| LSK02A              | Liquid Line Solenoid Kit | X             | X             | X             | X             | X             | X             |
| TX2N4A              | TXV Kit                  | X             |               |               |               |               |               |
| TX3N4               | TXV Kit                  |               | X             | X             |               |               |               |
| TX5N4               | TXV Kit                  |               |               |               | X             | X             | X             |

<sup>1</sup> Installed on indoor coil

<sup>2</sup> Required for heat pump applications where ambient temperatures fall below 0°F with 50% or higher relative humidity.

## ASX16/DSX16

| Model               | Description              | A/DSX16<br>024* | A/DSX16<br>030* | A/DSX16<br>036* | A/DSX16<br>042* | A/DSX16<br>048* | A/DSX16<br>060* |
|---------------------|--------------------------|-----------------|-----------------|-----------------|-----------------|-----------------|-----------------|
| ABK-20 <sup>1</sup> | Anchor Bracket Kit       | X               | X               | X               | X               | X               | X               |
| ASC01               | Anti-Short Cycle Kit     | X               | X               | X               | X               | X               | X               |
| CSR-U-1             | Hard-start Kit           | X               | X               | X               |                 |                 |                 |
| CSR-U-2             | Hard-start Kit           |                 |                 | X               | X               |                 |                 |
| CSR-U-3             | Hard-start Kit           |                 |                 |                 |                 | X               | X               |
| FSK01A <sup>1</sup> | Freeze Protection Kit    | X               | X               | X               | X               | X               | X               |
| LSK02A              | Liquid Line Solenoid Kit | X               | X               | X               | X               | X               | X               |
| TX2N4A              | TXV Kit                  | X               |                 |                 |                 |                 |                 |
| TX3N4               | TXV Kit                  |                 | X               | X               |                 |                 |                 |
| TX5N4               | TXV Kit                  |                 |                 |                 | X               | X               | X               |

<sup>1</sup> Installed on indoor coil

<sup>2</sup> Required for heat pump applications where ambient temperatures fall below 0°F with 50% or higher relative humidity.

## ASX/GSX16 (Rev F or Later)

| Model   | Description              | A/GSX16<br>018F* | A/GSX16<br>024F* | A/GSX16<br>030F* | A/GSX16<br>036F* | A/GSX16<br>042F* | A/GSX16<br>048F* | A/GSX16<br>060F* | A/GSX16<br>061F* |
|---------|--------------------------|------------------|------------------|------------------|------------------|------------------|------------------|------------------|------------------|
| ABK-20  | Anchor Bracket Kit       | X                | X                | X                | X                | X                | X                | X                | X                |
| ASC01   | Anti-Short Cycle Kit     | X                | X                | X                | X                | X                | X                | X                | X                |
| CSR-U-1 | Hard-start Kit           | X                | X                | X                | X                |                  |                  |                  |                  |
| CSR-U-2 | Hard-start Kit           |                  |                  |                  | X                | X                |                  |                  |                  |
| CSR-U-3 | Hard-start Kit           |                  |                  |                  |                  |                  | X                | X                | X                |
| FSK01A  | Freeze Protection Kit    | X                | X                | X                | X                | X                | X                | X                | X                |
| LSK02A  | Liquid Line Solenoid Kit | X                | X                | X                | X                | X                | X                | X                | X                |
| TXV-30  | Fixed TXV Kit            | X                | X                | X                |                  |                  |                  |                  |                  |
| TXV-42  | Fixed TXV Kit            |                  |                  |                  | X                | X                |                  |                  |                  |
| TXV-48  | Fixed TXV Kit            |                  |                  |                  |                  |                  | X                |                  |                  |
| TXV-60  | Fixed TXV Kit            |                  |                  |                  |                  |                  |                  | X                | X                |

<sup>1</sup> Installed on indoor coil

<sup>2</sup> Required for heat pump applications where ambient temperatures fall below 0°F with 50% or higher relative humidity.



# ACCESSORIES

## ASX/DSX18

| Model               | Description              | A/DSX18<br>036* | A/DSX18<br>048* | /DSX18<br>060* |
|---------------------|--------------------------|-----------------|-----------------|----------------|
| ABK-20 <sup>1</sup> | Anchor Bracket Kit       | X               | X               | X              |
| ASC01               | Anti-Short Cycle Kit     | X               | X               | X              |
| CSR-U-1             | Hard-start Kit           | X               |                 |                |
| CSR-U-2             | Hard-start Kit           | X               |                 |                |
| CSR-U-3             | Hard-start Kit           |                 | X               | X              |
| FSK01A <sup>1</sup> | Freeze Protection Kit    | X               | X               | X              |
| LSK02A              | Liquid Line Solenoid Kit | X               | X               | X              |
| TX2N4A              | TXV Kit                  |                 |                 |                |
| TX3N4               | TXV Kit                  | X               |                 |                |
| TX5N4               | TXV Kit                  |                 | X               | X              |

<sup>1</sup> Installed on indoor coil

<sup>2</sup> Required for heat pump applications where ambient temperatures fall below 0° F with 50% or higher relative humidity.

# ACCESSORIES

ComfortNet™

ASXC/DSXC 16

ASXC/DSXC 18

| Model                 | Description                | ASXC16024<br>DSXC16024 | ASXC16036<br>DSXC16036 | ASXC16048<br>DSXC16048 | ASXC16060<br>DSXC16060 | ASXC18036<br>DSXC18036 | ASXC18048<br>DSXC18048 | ASXC18060<br>DSXC18060 |
|-----------------------|----------------------------|------------------------|------------------------|------------------------|------------------------|------------------------|------------------------|------------------------|
| ABK-20                | Anchor Bracket Kit         | X                      | X                      | X                      | X                      | X                      | X                      | X                      |
| TX2N4A                | TXV Kit                    | X                      |                        |                        |                        |                        |                        |                        |
| TX3N4                 | TXV Kit                    |                        | X                      |                        |                        | X                      |                        |                        |
| TX5N4                 | TXV Kit                    |                        |                        | X                      | X                      |                        | X                      | X                      |
| CSR-U-1               | Hard-start Kit             | X                      | X                      |                        |                        | X                      |                        |                        |
| CSR-U-2               | Hard-start Kit             |                        |                        |                        |                        | X                      |                        |                        |
| CSR-U-3               | Hard-start Kit             |                        |                        | X                      | X                      |                        | X                      | X                      |
| FSK01A <sup>1</sup>   | Freeze Protection Kit      | X                      | X                      | X                      | X                      | X                      | X                      | X                      |
| LSK02                 | Liquid Line Solenoid Valve | X                      | X                      | X                      | X                      | X                      | X                      | X                      |
| B1141643 <sup>3</sup> | 24V Transformer            | X                      | X                      | X                      | X                      | X                      | X                      | X                      |

\* Contains 20 brackets; four brackets needed to anchor unit to pad.

Installed on the indoor coil.

Available in 24V legacy mode only. This feature is integrated in the communicating mode.

This component is included in the CTK0\*\*\* communicating thermostat kit.

# ACCESSORIES

## ASZ13

| Model                 | Description                       | ASZ13 018 | ASZ13 024 | ASZ13 030 | ASZ13 036 | ASZ13 042 | ASZ13 048 | ASZ13 060 |
|-----------------------|-----------------------------------|-----------|-----------|-----------|-----------|-----------|-----------|-----------|
| AFE18-60A             | All-Fuel Kit                      | X         | X         | X         | X         | X         | X         | X         |
| ASC01                 | Anti-Short Cycle Kit              | X         | X         | X         | X         | X         | X         | X         |
| CSR-U-1 <sup>4</sup>  | Hard-start Kit                    | X         | X         | X         | X         |           |           |           |
| CSR-U-2 <sup>4</sup>  | Hard-start Kit                    |           |           |           | X         | X         |           |           |
| CSR-U-3 <sup>4</sup>  | Hard-start Kit                    |           |           |           |           |           | X         | X         |
| FSK01A <sup>2</sup>   | Freeze Protection Kit             | X         | X         | X         | X         | X         | X         | X         |
| LSK02A                | Liquid Line Solenoid Kit          | X         | X         | X         | X         | X         | X         | X         |
| OT/EHR18-60           | Emergency Heat Relay kit          | X         | X         | X         | X         | X         | X         | X         |
| OT18-60A <sup>3</sup> | Outdoor Thermostat w/Lockout Stat | X         | X         | X         | X         | X         | X         | X         |
| TX2N4 <sup>4</sup>    | TXV Kit                           | X         | X         |           |           |           |           |           |
| TX3N4 <sup>4</sup>    | TXV Kit                           |           |           | X         | X         |           |           |           |
| TX5N4 <sup>4</sup>    | TXV Kit                           |           |           |           |           | X         | X         | X         |

## GSZ13

| Model                 | Description                       | G/VSZ13 018 | G/VSZ13 024 | G/VSZ13 030 | G/VSZ13 036 | G/VSZ13 042 | G/VSZ13 048 | G/VSZ13 060 |
|-----------------------|-----------------------------------|-------------|-------------|-------------|-------------|-------------|-------------|-------------|
| AFE18-60A             | All-Fuel Kit                      | X           | X           | X           | X           | X           | X           | X           |
| ASC01                 | Anti-Short Cycle Kit              | X           | X           | X           | X           | X           | X           | X           |
| CSB-15                | Sound Blanket                     |             |             |             |             | X           | X           | X           |
| CSB-16                | Sound Blanket                     | X           | X           | X           | X           |             |             |             |
| CSR-U-1 <sup>4</sup>  | Hard-start Kit                    | X           | X           | X           | X           |             |             |             |
| CSR-U-2 <sup>4</sup>  | Hard-start Kit                    |             |             |             | X           | X           |             |             |
| CSR-U-3 <sup>4</sup>  | Hard-start Kit                    |             |             |             |             |             | X           | X           |
| FSK01A <sup>2</sup>   | Freeze Protection Kit             | X           | X           | X           | X           | X           | X           | X           |
| LSK02A                | Liquid Line Solenoid Kit          | X           | X           | X           | X           | X           | X           | X           |
| OT/EHR18-60           | Emergency Heat Relay kit          | X           | X           | X           | X           | X           | X           | X           |
| OT18-60A <sup>3</sup> | Outdoor Thermostat w/Lockout Stat | X           | X           | X           | X           | X           | X           | X           |
| TX2N4 <sup>5</sup>    | TXV Kit                           | X           | X           |             |             |             |             |             |
| TX3N4 <sup>5</sup>    | TXV Kit                           |             |             | X           | X           |             |             |             |
| TX5N4 <sup>5</sup>    | TXV Kit                           |             |             |             |             | X           | X           | X           |

## GSZ13 Three-phase models

| Model                 | Description                       | GSZ13 036* | GSZ13 048* | GSZ13 048* | GSZ13 060* | GSZ13 060* |
|-----------------------|-----------------------------------|------------|------------|------------|------------|------------|
| AFE18-60A             | All-Fuel Kit                      | X          | X          | X          | X          | X          |
| ASC01                 | Anti-Short Cycle Kit              | X          | X          | X          | X          | X          |
| FSK01A <sup>2</sup>   | Freeze Protection Kit             | X          | X          | X          | X          | X          |
| LSK02A                | Liquid Line Solenoid Kit          | X          | X          | X          | X          | X          |
| OT/EHR18-60           | Emergency Heat Relay kit          | X          | X          | X          | X          | X          |
| OT18-60A <sup>3</sup> | Outdoor Thermostat w/Lockout Stat | X          | X          | X          | X          | X          |
| TX3N4 <sup>5</sup>    | TXV Kit                           | X          |            |            | X          |            |
| TX5N4 <sup>5</sup>    | TXV Kit                           |            | X          | X          |            | X          |
| CSB-15                | Sound Blanket Kit                 |            | X          | X          | X          | X          |
| CSB-16                | Sound Blanket Kit                 | X          |            |            |            |            |
| LAKT01                | Low Ambient Kit                   | X          | X          | X          | X          | X          |

<sup>1</sup> Contains 20 brackets; four brackets needed to anchor unit to pad

<sup>2</sup> Installed on indoor coil.

<sup>3</sup> Required for heat pump applications where ambient temperatures fall below 0°F with 50% or higher relative humidity.

<sup>4</sup> Condensing units & heat pumps with reciprocating compressors require the use of start-assist components when used in conjunction with an indoor coil using a non-bleed expansion valve refrigerant metering device.

<sup>5</sup> Field-installed, non-bleed, expansion valve kit - Condensing units and heat pumps with reciprocating compressors require the use of start-assist components when used in conjunction with an indoor coil using a non-bleed thermal expansion valve refrigerant.

# ACCESSORIES

## SSZ14

| Model                 | Description              | SSZ14<br>018* | SSZ14<br>024* | SSZ14<br>030* | SSZ14<br>036* | SSZ14<br>038* | SSZ14<br>042* | SSZ14<br>048* | SSZ14<br>060* |
|-----------------------|--------------------------|---------------|---------------|---------------|---------------|---------------|---------------|---------------|---------------|
| AFE18-60A             | All-Fuel Kit             | X             | X             | X             | X             | X             | X             | X             | X             |
| CSR-U-1               | Hard-start Kit           | X             | X             | X             | X             | X             |               |               |               |
| CSR-U-2               | Hard-start Kit           |               |               |               | X             | X             | X             |               |               |
| CSR-U-3               | Hard-start Kit           |               |               |               |               |               |               | X             | X             |
| FSK01A <sup>1</sup>   | Freeze Protection Kit    | X             | X             | X             | X             | X             | X             | X             | X             |
| LSK02A                | Liquid Line Solenoid Kit | X             | X             | X             | X             | X             | X             | X             | X             |
| OT18-60A <sup>2</sup> | Outdoor Thermostat       | X             | X             | X             | X             | X             | X             | X             | X             |
| OT/EHR18-60           | Emergency Heat Relat Kit | X             | X             | X             | X             | X             | X             | X             | X             |
| TX2N4A <sup>3</sup>   | TXV Kit                  | X             | X             |               |               |               |               |               |               |
| TX3N4 <sup>3</sup>    | TXV Kit                  |               |               | X             | X             | X             |               |               |               |
| TX5N4 <sup>3</sup>    | TXV Kit                  |               |               |               |               |               | X             | X             | X             |

## ASZ14

| Model                 | Description              | ASZ14<br>018* | ASZ14<br>024* | ASZ14<br>030* | ASZ14<br>036* | ASZ14<br>038* | ASZ14<br>042* | ASZ14<br>048* | ASZ14<br>060* |
|-----------------------|--------------------------|---------------|---------------|---------------|---------------|---------------|---------------|---------------|---------------|
| AFE18-60A             | All-Fuel Kit             | X             | X             | X             | X             | X             | X             | X             | X             |
| CSR-U-1               | Hard-start Kit           | X             | X             | X             | X             | X             |               |               |               |
| CSR-U-2               | Hard-start Kit           |               |               |               | X             | X             | X             |               |               |
| CSR-U-3               | Hard-start Kit           |               |               |               |               |               |               | X             | X             |
| FSK01A <sup>1</sup>   | Freeze Protection Kit    | X             | X             | X             | X             | X             | X             | X             | X             |
| LSK02A                | Liquid Line Solenoid Kit | X             | X             | X             | X             | X             | X             | X             | X             |
| OT18-60A <sup>2</sup> | Outdoor Thermostat       | X             | X             | X             | X             | X             | X             | X             | X             |
| OT/EHR18-60           | Emergency Heat Relat Kit | X             | X             | X             | X             | X             | X             | X             | X             |
| TX2N4A <sup>3</sup>   | TXV Kit                  | X             | X             |               |               |               |               |               |               |
| TX3N4 <sup>3</sup>    | TXV Kit                  |               |               | X             | X             | X             |               |               |               |
| TX5N4 <sup>3</sup>    | TXV Kit                  |               |               |               |               |               | X             | X             | X             |

## GSZ14

| Model                 | Description              | GSZ14<br>018* | GSZ14<br>024* | GSZ14<br>030* | GSZ14<br>036* | GSZ14<br>042* | GSZ14<br>048* | GSZ14<br>060* |
|-----------------------|--------------------------|---------------|---------------|---------------|---------------|---------------|---------------|---------------|
| AFE18-60A             | All-Fuel Kit             | X             | X             | X             | X             | X             | X             | X             |
| CSR-U-1               | Hard-start Kit           | X             | X             | X             | X             |               |               |               |
| CSR-U-2               | Hard-start Kit           |               |               |               | X             | X             |               |               |
| CSR-U-3               | Hard-start Kit           |               |               |               |               |               | X             | X             |
| FSK01A <sup>1</sup>   | Freeze Protection Kit    | X             | X             | X             | X             | X             | X             | X             |
| LSK02A                | Liquid Line Solenoid Kit | X             | X             | X             | X             | X             | X             | X             |
| OT18-60A <sup>2</sup> | Outdoor Thermostat       | X             | X             | X             | X             | X             | X             | X             |
| OT/EHR18-60           | Emergency Heat Relat Kit | X             | X             | X             | X             | X             | X             | X             |
| TX2N4A <sup>3</sup>   | TXV Kit                  | X             | X             |               |               |               |               |               |
| TX3N4 <sup>3</sup>    | TXV Kit                  |               |               | X             | X             |               |               |               |
| TX5N4 <sup>3</sup>    | TXV Kit                  |               |               |               |               | X             | X             | X             |
| CSB-15                | Sound Blanket Kit        |               |               |               |               | X             | X             | X             |
| CSB-16                | Sound Blanket Kit        | X             | X             | X             | X             |               |               |               |

<sup>1</sup> Installed on indoor coil

<sup>2</sup> Required for heat pump applications where ambient temperatures fall below 0°F with 50% or higher relative humidity.

# ACCESSORIES

## ASZ16/DSZ16

| Model                 | Description                        | A/DSZ16<br>024* | A/DSZ16<br>030* | A/DSZ16<br>036* | A/DSZ16<br>042* | A/DSZ16<br>048* | A/DSZ16<br>060* |
|-----------------------|------------------------------------|-----------------|-----------------|-----------------|-----------------|-----------------|-----------------|
| AFE18-60A             | All-Fuel Kit                       | X               | X               | X               | X               | X               | X               |
| CSR-U-1               | Hard-start Kit                     | X               | X               | X               |                 |                 |                 |
| CSR-U-2               | Hard-start Kit                     |                 |                 | X               | X               |                 |                 |
| CSR-U-3               | Hard-start Kit                     |                 |                 |                 |                 | X               | X               |
| FSK01A <sup>1</sup>   | Freeze Protection Kit              | X               | X               | X               | X               | X               | X               |
| LSK02A                | Liquid Line Solenoid Kit           | X               | X               | X               | X               | X               | X               |
| OT/EHR18-60           | Emergency Heat Relay Kit           | X               | X               | X               | X               | X               | X               |
| OT18-60A <sup>2</sup> | Outdoor Thermostat w/ Lockout Stat | X               | X               | X               | X               | X               | X               |
| TX2N4A                | TXV Kit                            | X               |                 |                 |                 |                 |                 |
| TX3N4                 | TXV Kit                            |                 | X               | X               |                 |                 |                 |
| TX5N4                 | TXV Kit                            |                 |                 |                 | X               | X               | X               |

<sup>1</sup> Installed on indoor coil

<sup>2</sup> Required for heat pump applications where ambient temperatures fall below 0°F with 50% or higher relative humidity.

## SSZ16

| Model                 | Description                        | SSZ16<br>024* | SSZ16<br>030* | SSZ16<br>036* | SSZ16<br>042* | SSZ16<br>048* | SSZ16<br>060* |
|-----------------------|------------------------------------|---------------|---------------|---------------|---------------|---------------|---------------|
| AFE18-60A             | All-Fuel Kit                       | X             | X             | X             | X             | X             | X             |
| CSR-U-1               | Hard-start Kit                     | X             | X             | X             |               |               |               |
| CSR-U-2               | Hard-start Kit                     |               |               | X             | X             | X             | X             |
| CSR-U-3               | Hard-start Kit                     |               |               |               |               | X             | X             |
| FSK01A <sup>1</sup>   | Freeze Protection Kit              | X             | X             | X             | X             | X             | X             |
| LSK02A                | Liquid Line Solenoid Kit           | X             | X             | X             | X             | X             | X             |
| OT/EHR18-60           | Emergency Heat Relay Kit           | X             | X             | X             | X             | X             | X             |
| OT18-60A <sup>2</sup> | Outdoor Thermostat w/ Lockout Stat | X             | X             | X             | X             | X             | X             |
| TX2N4A                | TXV Kit                            | X             |               |               |               |               |               |
| TX3N4                 | TXV Kit                            |               | X             | X             |               |               |               |
| TX5N4                 | TXV Kit                            |               |               |               | X             | X             | X             |

<sup>1</sup> Installed on indoor coil

<sup>2</sup> Required for heat pump applications where ambient temperatures fall below 0°F with 50% or higher relative humidity.

# ACCESSORIES

## ASZ/DSZ18

| Model                 | Description                        | A/DSZ18<br>036* | A/DSZ18<br>048* | A/DSZ18<br>060* |
|-----------------------|------------------------------------|-----------------|-----------------|-----------------|
| AFE18-60A             | All-Fuel Kit                       | X               | X               | X               |
| CSR-U-1               | Hard-start Kit                     | X               |                 |                 |
| CSR-U-2               | Hard-start Kit                     | X               |                 |                 |
| CSR-U-3               | Hard-start Kit                     |                 | X               | X               |
| FSK01A <sup>1</sup>   | Freeze Protection Kit              | X               | X               | X               |
| LSK02A                | Liquid Line Solenoid Kit           | X               | X               | X               |
| OT/EHR18-60           | Emergency Heat Relay Kit           | X               | X               | X               |
| OT18-60A <sup>2</sup> | Outdoor Thermostat w/ Lockout Stat | X               | X               | X               |
| TX2N4A <sup>3</sup>   | TXV Kit                            |                 |                 |                 |
| TX3N4 <sup>3</sup>    | TXV Kit                            | X               |                 |                 |
| TX5N4 <sup>3</sup>    | TXV Kit                            |                 | X               | X               |

<sup>1</sup> Installed on indoor coil

<sup>2</sup> Require for heat pump applications where ambient temperatures fall below 0°F with 50% or higher relative humidity.

<sup>3</sup> Field-installed, non-bleed, expansion valve kit — Condensing units and heat pumps with reciprocating compressors require the use of start-assist components when used in conjunction with an indoor coil using a non-bleed thermal expansion valve refrigerant metering device.

# ACCESSORIES

**ASZC/DSZC 16**  
**ASZC/DSZC 18**

| Model                 | Description                               | ASZC16024<br>DSZC16024 | ASZC16036<br>DSZC16036 | ASZC16048<br>DSZC16048 | ASZC16060<br>DSZC16060 | ASZC18036<br>DSZC18036 | ASZC18048<br>DSZC18048 | ASZC18060<br>DSZC18060 |
|-----------------------|---|------------------------|------------------------|------------------------|------------------------|------------------------|------------------------|------------------------|
| ABK-20                | Anchor Bracket Kit                        | X                      | X                      | X                      | X                      | X                      | X                      | X                      |
| TX2N4 <sup>1</sup>    | TXV Kit                                   | X                      |                        |                        |                        |                        |                        |                        |
| TX3N4 <sup>1</sup>    | TXV Kit                                   |                        | X                      |                        |                        | X                      |                        |                        |
| TX5N4 <sup>1</sup>    | TXV Kit                                   |                        |                        | X                      | X                      |                        | X                      | X                      |
| CSR-U-1               | Hard-start Kit                            | X                      | X                      |                        |                        | X                      |                        |                        |
| CSR-U-2               | Hard-start Kit                            |                        | X                      | X                      | X                      | X                      | X                      | X                      |
| CSR-U-3               | Hard-start Kit                            |                        |                        | X                      | X                      |                        | X                      | X                      |
| FSK01A <sup>2</sup>   | Freeze Protection Kit                     | X                      | X                      | X                      | X                      | X                      | X                      | X                      |
| OT18-60A <sup>3</sup> | Outdoor Thermostat/<br>Lockout Thermostat | X                      | X                      | X                      | X                      | X                      | X                      | X                      |
| B1141643 <sup>4</sup> | 24V Transformer                           | X                      | X                      | X                      | X                      | X                      | X                      | X                      |

\* Contains 20 brackets; four brackets needed to anchor unit to pad

<sup>1</sup> Field-installed, non-bleed, expansion valve kit - Condensing units and heap pumps with reciprocating compressors require the use of start-assist components when used in conjunction with an indoor coil using a non-bleed thermal expansion valve refrigerant

<sup>2</sup> Installed on the indoor coil

<sup>3</sup> Available in 24V legacy mode only. This feature is integrated in the communicating mode. Required for heat pump applications where ambient temperature fall below 0 °F with 50% or higher relative humidity.

<sup>4</sup> This component is included in the CTK0\*\*\* communicating thermostat kit.

# ACCESSORIES

## EXPANSION VALVE KITS

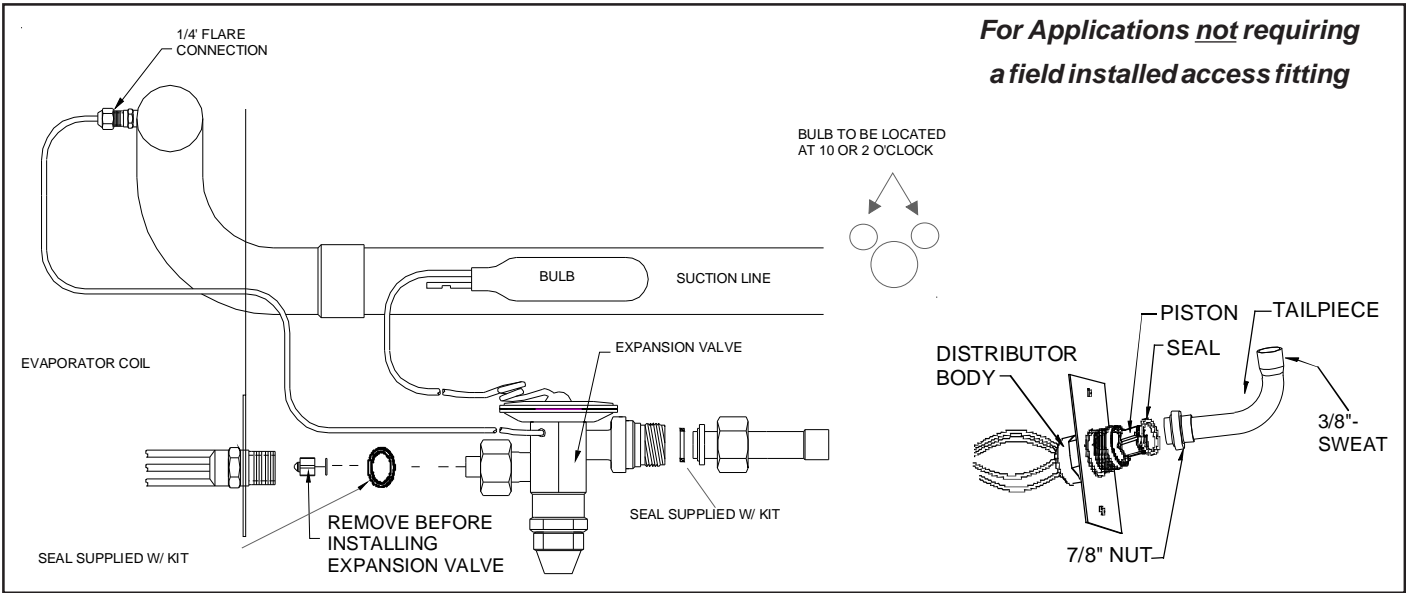
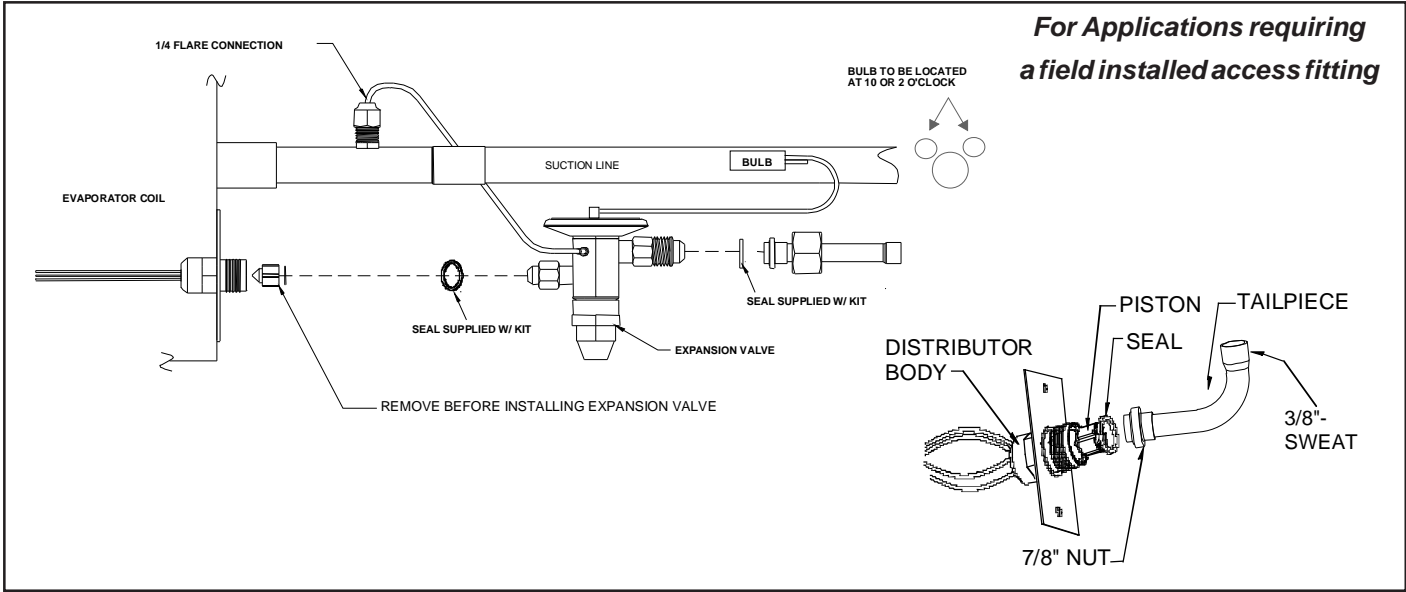

### OT/EHR18-60

## OUTDOOR THERMOSTAT & EMERGENCY HEAT RELAY

**OT18-60**

Thermostat Dial

315°

45°

COLD (Fan On/Off)

WARM (Fan On/Off)

DEAD DIAL

Set Point Adjustment Screw

Set Point Indicator Mark (Shown @ 0° F)

**Not for use with ComfortNet System**



# ACCESSORIES

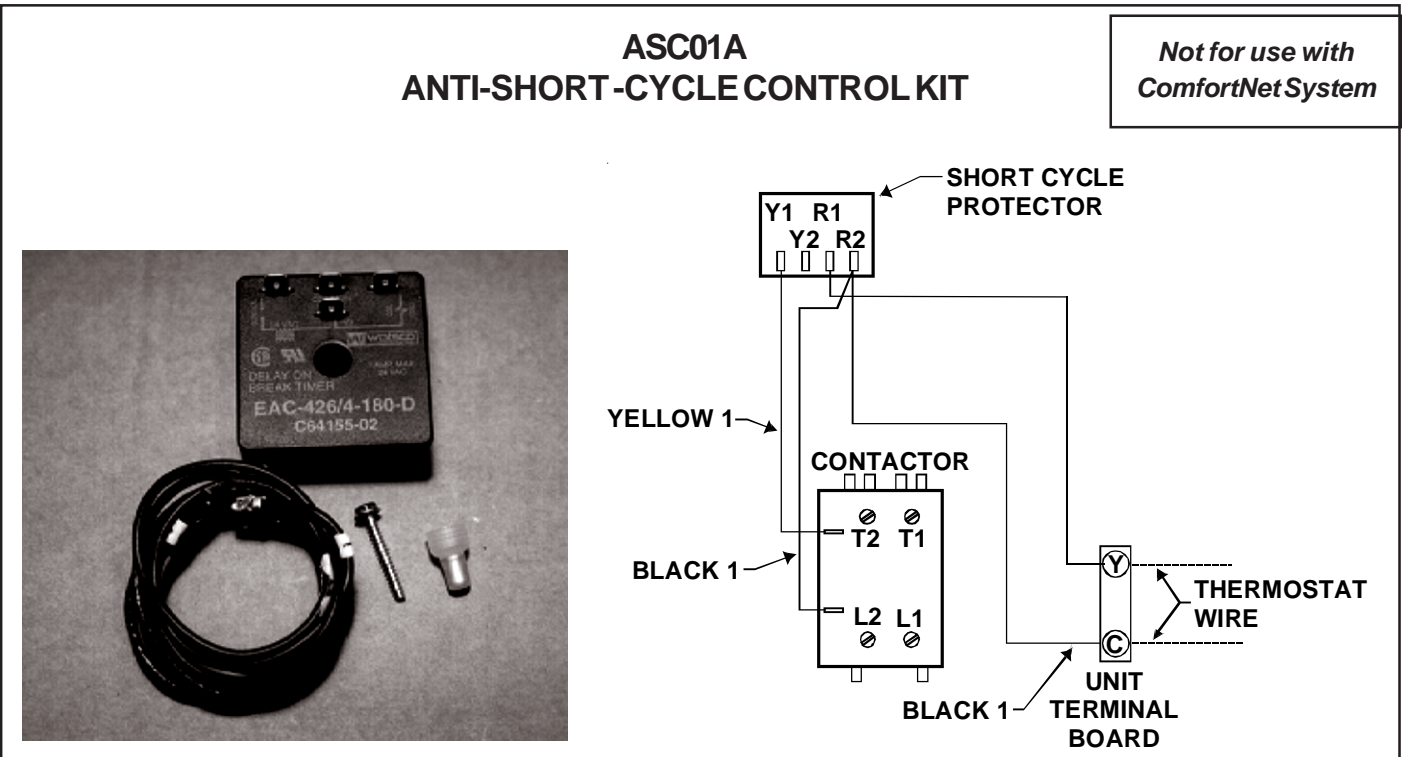
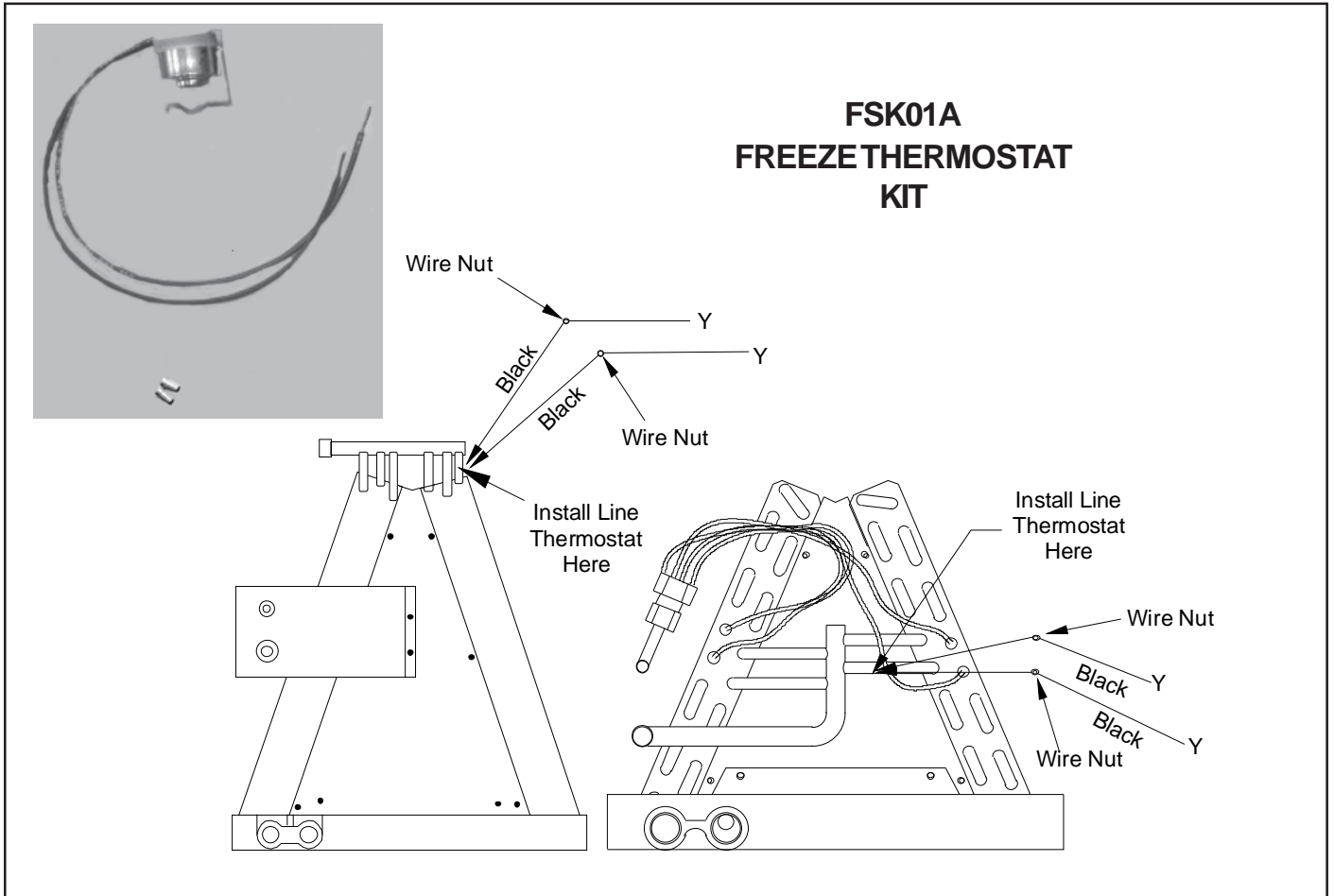

# ACCESSORIES

## COIL ACCESSORIES

| COIL MODEL  | TX2N4A<br>TXV KIT | TX3N4<br>TXV KIT | TX5N4<br>TXV KIT | FSK01A FREEZE<br>PROTECTION KIT |
|-------------|-------------------|------------------|------------------|---------------------------------|
| CA*F18246*  | X                 |                  |                  | X                               |
| CA*F30306*  |                   | X                |                  | X                               |
| CA*F31316*  |                   |                  |                  |                                 |
| CA*F36366*  |                   |                  |                  |                                 |
| CA*F36426*  |                   | X                | X                | X                               |
| CA*F37436*  |                   |                  |                  |                                 |
| CA*F48606*  |                   |                  |                  |                                 |
| CA*F49616*  |                   |                  |                  |                                 |
| CHPF18246*  | X                 |                  |                  | X                               |
| CHPF24306*  |                   |                  |                  |                                 |
| CHPF36366*  |                   | X                |                  | X                               |
| CHPF36426*  |                   |                  | X                | X                               |
| CHPF37436*  |                   |                  |                  |                                 |
| CHPF48606*  |                   |                  |                  |                                 |
| CSCF1824N6* | X                 |                  |                  | X                               |
| CSCF3036N6* |                   | X                |                  | X                               |
| CSCF3642N6* |                   | X                | X                | X                               |
| CSCF4860N6* |                   |                  |                  |                                 |



## HK\* SERIES ELETRIC HEAT KITS - ELECTRIC HEAT KIT APPLICATIONS - MBR, MBE, MBVC

| BLOWER         | ELECTRIC HEAT KIT |         |            |         |            |            |          |          |           |           |
|----------------|-------------------|---------|------------|---------|------------|------------|----------|----------|-----------|-----------|
|                | NO HEAT           | HKR-03* | HKR05-(C)* | HKR-06* | HKR-08(C)* | HKR-10(C)* | HKA-15C* | HKA-20C* | ^HKR3-15* | ^HKR3-20A |
| MBR0800AA-1AA  | -                 | X       | X          | X       | X          | X          | -        | -        |           |           |
| MBR1200AA-1AA  | -                 | X       | X          | X       | X          | X          | X        | X        | X         | X         |
| MBR1600AA-1AA  | -                 | X       | X          | X       | X          | X          | X        | X        | X         | X         |
| MBR2000AA-1AA  | -                 | X       | X          | X       | X          | X          | X        | X        | X         | X         |
| MBE1200AA-1AA  | -                 | -       | -          | -       | X          | X          | -        | -        | -         | -         |
| MBE1600AA-1AA  | -                 | -       | -          | -       | -          | X          | -        | -        | -         | -         |
| MBE2000AA-1AA  | -                 | -       | -          | -       | -          | X          | -        | -        | -         | -         |
| MBE1200AA-1BA  | -                 | X       | X          | X       | X          | X          | -        | -        | -         | -         |
| MBE1600AA-1BA  | -                 | X       | X          | X       | X          | X          | -        | -        | -         | -         |
| MBE2000AA-1AA  | -                 | X       | X          | X       | X          | X          | -        | -        | -         | -         |
| MBVC1200AA-1** | -                 | X       | X          | X       | X          | X          | X        | -        | -         | -         |
| MBVC1600AA-1** | -                 | X       | X          | X       | X          | X          | X        | -        | -         | -         |
| MBVC2000AA-1** | -                 | X       | X          | X       | X          | X          | -        | X        | -         | -         |

X = Allowable combinations  
- = Restricted combinations

^ = Circuit 1: Single Phase for Air Handler Motor  
Circuit 2: 3-Phase for HKR3 Heater Kits

# ACCESSORIES

## ELECTRIC HEAT KIT APPLICATIONS - ARPF

|                   | ARPF1824<br>1/16 | ARPF1931<br>1/16 | ARPF3030<br>1/16 | ARPF3642<br>1/16 | ARPF3743<br>1/16 | ARPF4860<br>1/16 |
|-------------------|------------------|------------------|------------------|------------------|------------------|------------------|
| HKR-03*           | X                | X                | X                | X                | X                | X                |
| HKR-05*, HKR-05C* | X                | X                | X                | X                | X                | X                |
| HKR-06*           | X                | X                | X                | X                | X                | X                |
| HKR-08*, HKR-08C* | X <sup>1</sup>   | X <sup>1</sup>   | X                | X                | X                | X                |
| HKR-10*, HKR-10C* | X <sup>1</sup>   | X <sup>1</sup>   | X <sup>1</sup>   | X                | X                | X                |
| HKA-15C*          | X <sup>2</sup>   | X <sup>2</sup>   | X <sup>2</sup>   | X <sup>3</sup>   | X <sup>3</sup>   | X                |
| HKA-20C*          |                  |                  | X <sup>2</sup>   | X <sup>3</sup>   | X <sup>3</sup>   | X                |
| ^ HKR3-15*        |                  |                  | X <sup>2</sup>   | X <sup>3</sup>   | X <sup>3</sup>   | X                |
| ^ HKR3-20*        |                  |                  | X <sup>2</sup>   | X <sup>3</sup>   | X <sup>3</sup>   | X                |

\* Revision level that may or may not be designated

C Circuit breaker option

^ Heat kit required three-phase power supply

<sup>1</sup> Air handler must either be on medium or high speed

<sup>2</sup> Air handler must be on high speed

<sup>3</sup> For static pressure of 0.6 or higher, air handler must be on medium or high speed.

## ELECTRIC HEAT KIT APPLICATIONS-ARUF

|                   | ARUF1729<br>1/16 | ARUF1824<br>1/16 | ARUF1931<br>1/16 | ARUF3030<br>1/16 | ARUF3642<br>1/16 | ARUF3743<br>1/16 | ARUF4860<br>1/16 |
|-------------------|------------------|------------------|------------------|------------------|------------------|------------------|------------------|
| HKR-03*           | X                | X                | X                | X                | X                | X                | X                |
| HKR-05*, HKR-05C* | X                | X                | X                | X                | X                | X                | X                |
| HKR-06*           | X                | X                | X                | X                | X                | X                | X                |
| HKR-08*, HKR-08C* | X <sup>1</sup>   | X <sup>1</sup>   | X <sup>1</sup>   | X                | X                | X                | X                |
| HKR-10*, HKR-10C* | X <sup>1</sup>   | X <sup>1</sup>   | X <sup>1</sup>   | X <sup>1</sup>   | X                | X                | X                |
| HKA-15C*          | X <sup>2</sup>   | X <sup>2</sup>   | X <sup>2</sup>   | X <sup>2</sup>   | X <sup>3</sup>   | X <sup>3</sup>   | X                |
| HKA-20C*          |                  |                  |                  | X <sup>2</sup>   | X <sup>3</sup>   | X <sup>3</sup>   | X                |
| ^ HKR3-15*        |                  |                  |                  | X <sup>2</sup>   | X <sup>3</sup>   | X <sup>3</sup>   | X                |
| ^ HKR3-20*        |                  |                  |                  | X <sup>2</sup>   | X <sup>3</sup>   | X <sup>3</sup>   | X                |

\* Revision level that may or may not be designated

C Circuit breaker option

^ Heat kit required three-phase power supply

<sup>1</sup> Air handler must either be on medium or high speed

<sup>2</sup> Air handler must be on high speed

<sup>3</sup> For static pressure of 0.6 or higher, air handler must be on medium or high speed.

# ACCESSORIES

## ELECTRIC HEAT KIT APPLICATIONS - ADPF

|                   | ADPF182416     | ADPF304216     | ADPF486016     | ADPF4486016    |
|-------------------|----------------|----------------|----------------|----------------|
| HKR-03*           | X              | X              | X              | X              |
| HKR-05*, HKR-05C* | X              | X              | X              | X              |
| HKR-06*           | X              | X              | X              | X              |
| HRK-08*, HKR-08C* | X <sup>1</sup> | X <sup>1</sup> | X <sup>1</sup> | X              |
| HKR-10*, HKR-10C* | X <sup>1</sup> | X <sup>1</sup> | X <sup>1</sup> | X              |
| HKA-15C*          | X              | X              | X <sup>2</sup> | X <sup>1</sup> |
| HKA-20C*          | -              | X              | X <sup>2</sup> | X <sup>1</sup> |
| ^HKR3-15*         | -              | X              | X              | X              |
| ^HKR3-20*         | -              | X              | X              | X              |

\* Revision level that may or may not be designated

C Circuit Breaker option

^ Heat kit requires 3-phase power supply

<sup>1</sup> Air handler must be on speed tap 2, 3, 4 or 5

<sup>2</sup> Air handler must be on speed tap 4 or 5

<sup>3</sup> Air handler must be on speed tap 3, 4 or 5

## ELECTRIC HEAT KIT APPLICATIONS - AEPF

|                   | AEPF183016     | AEPF303616     | AEPF313716     | AEPF426016     |
|-------------------|----------------|----------------|----------------|----------------|
| HKR-05*, HKR-05C* | X              |                | X              |                |
| HRK-08*, HKR-08C  | X              | X              | X              |                |
| HKR-10*, HKR-10C  | X <sup>1</sup> | X              | X              | X              |
| HKA-15C*          |                | X <sup>1</sup> | X <sup>1</sup> | X              |
| HKA-20C*          |                |                |                | X <sup>2</sup> |

\* Revision level that may or may not be designated

C Circuit Breaker option

<sup>1</sup> This heater kit can be used ONLY for **1000 CFM or higher** applications

<sup>2</sup> This heater kit can be used ONLY for **1200 CFM or higher** applications

## ELECTRIC HEAT KIT APPLICATIONS - AVPTC

| MODELS        | HKR-03* | HKR-05*/-05C* | HKR-06* | HKR-08*/-08C*  | HKR-10*/-10C*  | HKA-15C*       | HKA-20C*       |
|---------------|---------|---------------|---------|----------------|----------------|----------------|----------------|
| AVPTC183014A* | X       | X             | X       | X <sup>1</sup> | X <sup>1</sup> | ---            | ---            |
| AVPTC313714A* | X       | X             | X       | X <sup>1</sup> | X <sup>1</sup> | X <sup>2</sup> | X              |
| AVPTC426014A* | X       | X             | X       | X              | X              | X              | X <sup>3</sup> |

\* Revision level that may or may not be designated.

C Circuit breaker option.

### NOTE:

When 8kW and 10kW heat kits are used with an AVPTC1830 and AVPTC3137, matched with 2-ton outdoor unit, see Note 1 below.

<sup>1</sup> Set Heater Kit dip switches 9, 10 and 11 to 6kW setting (9-ON, 10-OFF, 11-ON) to obtain 840 CFM.

<sup>2</sup> This heater kit can only be used for '1000 CFM or higher' applications.

<sup>3</sup> This heater kit can only be used for '1200 CFM or higher' applications.

# ACCESSORIES

## ELECTRIC HEAT KIT APPLICATIONS - ASPF

|                   | ASPF183016     | ASPF 303616    | ASPF313716     | ASPF 426016    |
|-------------------|----------------|----------------|----------------|----------------|
| HKR-03*           | X              | X              | X              | X              |
| HKR-05*, HKR-05C* | X              | X              | X              | X              |
| HKR-06*           | X              | X              | X              | X              |
| HRK-08*, HKR-08C* | X <sup>1</sup> | X <sup>1</sup> | X <sup>1</sup> | X              |
| HKR-10*, HKR-10C* | X <sup>1</sup> | X <sup>1</sup> | X <sup>1</sup> | X              |
| +HKR3-15*         | X <sup>2</sup> | X <sup>2</sup> | X <sup>2</sup> | X <sup>1</sup> |
| +HKR3-20*         |                | X <sup>2</sup> | X <sup>2</sup> | X <sup>1</sup> |
| HKA-15C*          | X <sup>2</sup> | X <sup>2</sup> | X <sup>2</sup> | X <sup>1</sup> |
| HKA-20C*          |                | X <sup>2</sup> | X <sup>2</sup> | X <sup>1</sup> |

\* Revision level that may or may not be designated

C Circuit Breaker option

+ Heat kit requires 3-phase power supply

<sup>1</sup> Air handler must be on speed tap 2, 3, 4 or 5

<sup>2</sup> Air handler must be on speed tap 4 or 5

<sup>3</sup> Air handler must be on speed tap 3, 4 or 5

---

## DRAIN PAN INSULATION KITS - ARUF\*\*14\*\*, ARPT\*\*14\*\*, ASPT\*\*14\*\* & ASUF\*\*14\*\* MODEL LIST FOR DOWNFLOW KITS

| DFK-B<br>Downflow Kit | DFK-C<br>Downflow Kit | DFK-D<br>Downflow Kit |
|-----------------------|-----------------------|-----------------------|
| ARUF18B14**           | ARUF30C14**           | ARUF48D14**           |
| ARUF24B14**           | ARUF36C14**           | ARUF60D14**           |
| ARUF30B14**           | ARUF42C14**           | ARPT36D14**           |
| ARPT18B14**           | ARPT36C14**           | ARPT42D14**           |
| ARPT24B14**           | ASPT36C14**           | ARPT48D14**           |
| ARPT30B14**           | ASPT42C14**           | ARPT60D14**           |
| ASPT24B14**           | ASPT48C14**           | ASPT48D14**           |
|                       | ASUF49C14**           | ASPT60D14**           |
|                       |                       | ASUF59D14**           |

# ACCESSORIES

## ARPT\*\*14\*\*

| Heat Kit Applications | ARPT     |          |          |          |          |          |          |          |
|-----------------------|----------|----------|----------|----------|----------|----------|----------|----------|
|                       | 18B14-A* | 24B14-A* | 30B14-A* | 36C14-A* | 36D14-A* | 42D14-A* | 48D14-A* | 60D14-A* |
| HKSX03XC*             | X        | X        | X        | X        | X        | X        | X        | X        |
| HKSX05XC*             | X        | X        | X        | X        | X        | X        | X        | X        |
| HKSX06XC*             | X        | X        | X        | X        | X        | X        | X        | X        |
| HKSX08XC*             | X        | X        | X        | X        | X        | X        | X        | X        |
| HKSX10XC*             | X        | X        | X        | X        | X        | X        | X        | X        |
| HKSX15XF*             |          |          |          | X        | X        | X        | X        | X        |
| HKSX20XF*             |          |          |          | X        | X        | X        | X        | X        |
| HKSC05XC*             | X        | X        | X        | X        | X        | X        | X        | X        |
| HKSC08XC*             | X        | X        | X        | X        | X        | X        | X        | X        |
| HKSC10XC*             | X        | X        | X        | X        | X        | X        | X        | X        |
| HKSC15XA*             |          |          | X        | X        | X        | X        | X        | X        |
| HKSC15XB*             |          |          | X        | X        | X        | X        | X        | X        |
| HKSC15XF*             |          |          |          | X        | X        | X        | X        | X        |
| HKSC19CA*             |          |          |          | X        |          |          |          |          |
| HKSC19CB*             |          |          |          | X        |          |          |          |          |
| HKSC20DA*             |          |          |          |          | X        | X        | X        | X        |
| HKSC20DB*             |          |          |          |          | X        | X        | X        | X        |
| HKSC20XF*             |          |          |          | X        | X        | X        | X        | X        |

# ACCESSORIES

## ARUF\*\*14\*\*

| Heat Kit Applications | ARUF     |          |          |          |          |          |          |          |          |
|-----------------------|----------|----------|----------|----------|----------|----------|----------|----------|----------|
|                       | 18B14-A* | 24B14-B* | 24B14-C* | 30B14-A* | 30C14-B* | 36C14-B* | 42C14-A* | 48D14-A* | 60D14-A* |
| HKSX03XC*             | X        | X        | X        | X        | X        | X        | X        | X        | X        |
| HKSX05XC*             | X        | X        | X        | X        | X        | X        | X        | X        | X        |
| HKSX06XC*             | X        | X        | X        | X        | X        | X        | X        | X        | X        |
| HKSX08XC*             | X        | X        | X        | X        | X        | X        | X        | X        | X        |
| HKSX10XC*             | X        | X        | X        | X        | X        | X        | X        | X        | X        |
| HKSX15XF*             |          |          |          |          | X        | X        | X        | X        | X        |
| HKSX20XF*             |          |          |          |          | X        | X        | X        | X        | X        |
| HKSC05XC*             | X        | X        | X        | X        | X        | X        | X        | X        | X        |
| HKSC08XC*             | X        | X        | X        | X        | X        | X        | X        | X        | X        |
| HKSC10XC*             | X        | X        | X        | X        | X        | X        | X        | X        | X        |
| HKSC15XA*             |          |          |          | X        | X        | X        | X        | X        | X        |
| HKSC15XB*             |          |          |          | X        | X        | X        | X        | X        | X        |
| HKSC15XF*             |          |          |          |          | X        | X        | X        | X        | X        |
| HKSC19CA*             |          |          |          |          | X        | X        | X        |          |          |
| HKSC19CB*             |          |          |          |          | X        | X        | X        |          |          |
| HKSC20DA*             |          |          |          |          |          |          |          | X        | X        |
| HKSC20DB*             |          |          |          |          |          |          |          | X        | X        |
| HKSC20XF*             |          |          |          |          | X        | X        | X        | X        | X        |
| HKSC25DC*             |          |          |          |          |          |          | X        | X        | X        |

\* Revision level that may or may not be designated

Refer to the minimum airflow requirements for each of the heat kits.

| *ARUF<br>ARPT | HEATER (kW) |      |      |      |      |      |      |      |      |
|---------------|-------------|------|------|------|------|------|------|------|------|
|               | 3           | 5    | 6    | 8    | 10   | 15   | 19   | 20   | 25   |
| 18            | 715         | 715  | 715  | 715  | 950  |      |      |      |      |
| 24            | 715         | 715  | 715  | 715  | 950  |      |      |      |      |
| 30B           | 715         | 715  | 715  | 715  | 875  | 875  |      |      |      |
| 30C           |             | 1170 | 1170 | 1170 | 1170 | 1345 | 1345 |      |      |
| 36            |             | 1170 | 1170 | 1170 | 1170 | 1345 | 1345 |      |      |
| 42            |             | 1170 | 1170 | 1170 | 1170 | 1345 | 1345 |      |      |
| 48            |             | 1590 | 1590 | 1590 | 1590 | 1715 |      | 1715 | 1715 |
| 60            |             | 1590 | 1590 | 1590 | 1590 | 1715 |      | 1715 | 1715 |

Minimum CFM required for Heater Kits

# ACCESSORIES

## ASUF\*\*14\*\*

| Heat Kit Applications | ASUF     |          |          |          |
|-----------------------|----------|----------|----------|----------|
|                       | 29B14-A* | 39C14-A* | 49C14-A* | 59D14-A* |
| Type / model          |          |          |          |          |
| HKSX03XC*             | X        | X        | X        | X        |
| HKSX05XC*             | X        | X        | X        | X        |
| HKSX06XC*             | X        | X        | X        | X        |
| HKSX08XC*             | X        | X        | X        | X        |
| HKSX10XC*             | X        | X        | X        | X        |
| HKSX15XF*             |          | X        | X        | X        |
| HKSX20XF*             |          | X        | X        | X        |
| HKSC05XC*             | X        | X        | X        | X        |
| HKSC08XC*             | X        | X        | X        | X        |
| HKSC10XC*             | X        | X        | X        | X        |
| HKSC15XA*             |          | X        | X        | X        |
| HKSC15XB*             |          | X        | X        | X        |
| HKSC15XF*             |          | X        | X        | X        |
| HKSC19CA*             |          | X        | X        |          |
| HKSC19CB*             |          | X        | X        |          |
| HKSC20DA*             |          |          |          | X        |
| HKSC20DB*             |          |          |          | X        |
| HKSC20XF*             |          | X        | X        | X        |
| HKSC25DC*             |          |          |          | X        |

\* Revision level that may or may not be designated.

Refer to the minimum airflow requirements for each of the heat kits.

| ASUF | HEATER (kW) |      |      |      |      |      |      |      |      |
|------|-------------|------|------|------|------|------|------|------|------|
|      | 3           | 5    | 6    | 8    | 10   | 15   | 19   | 20   | 25   |
| 29   | 715         | 715  | 715  | 715  | 875  |      |      |      |      |
| 39   |             | 1170 | 1170 | 1170 | 1170 | 1345 | 1345 |      |      |
| 49   |             | 1170 | 1170 | 1170 | 1170 | 1345 | 1345 |      |      |
| 59   |             | 1590 | 1590 | 1590 | 1590 | 1715 |      | 1715 | 1715 |

Minimum CFM required for Heater Kits



# ACCESSORIES

## ASPT\*\*14\*\*

| Heat Kit Applications | ASPT     |          |          |          |          |          |          |          |
|-----------------------|----------|----------|----------|----------|----------|----------|----------|----------|
| Type / model          | 24B14-A* | 30C14-A* | 36C14-A* | 42C14-A* | 48C14-A* | 42D14-A* | 48D14-A* | 60D14-A* |
| HKSX03XC*             | X        | X        | X        | X        | X        | X        | X        | X        |
| HKSX05XC*             | X        | X        | X        | X        | X        | X        | X        | X        |
| HKSX06XC*             | X        | X        | X        | X        | X        | X        | X        | X        |
| HKSX08XC*             | X        | X        | X        | X        | X        | X        | X        | X        |
| HKSX10XC*             | X        | X        | X        | X        | X        | X        | X        | X        |
| HKSX15XF*             |          |          | X        | X        | X        | X        | X        | X        |
| HKSX20XF*             |          |          | X        | X        | X        | X        | X        | X        |
| HKSC05XC*             | X        | X        | X        | X        | X        | X        | X        | X        |
| HKSC08XC*             | X        | X        | X        | X        | X        | X        | X        | X        |
| HKSC10XC*             | X        | X        | X        | X        | X        | X        | X        | X        |
| HKSC15XA*             |          |          | X        | X        | X        | X        | X        | X        |
| HKSC15XB*             |          |          | X        | X        | X        | X        | X        | X        |
| HKSC15XF*             |          |          | X        | X        | X        | X        | X        | X        |
| HKSC19CA*             |          |          | X        | X        | X        |          |          |          |
| HKSC19CB*             |          |          | X        | X        | X        |          |          |          |
| HKSC20DA*             |          |          |          |          |          | X        | X        | X        |
| HKSC20DB*             |          |          |          |          |          | X        | X        | X        |
| HKSC20XF*             |          |          | X        | X        | X        | X        | X        | X        |
| HKSC25DC*             |          |          |          |          |          |          | X        | X        |

\* Revision level that may or may not be designated.

Refer to the minimum airflow requirements for each of the heat kits.

|          | Heater (KW) |      |      |      |      |      |      |      |      |
|----------|-------------|------|------|------|------|------|------|------|------|
|          | 3           | 5    | 6    | 8    | 10   | 15   | 19   | 20   | 25   |
| ASPT24B1 | 715         | 715  | 715  | 715  | 875  | NR   | NR   | NR   | NR   |
| ASPT30C1 | 730         | 715  | 715  | 715  | 950  | NR   | NR   | NR   | NR   |
| ASPT36C1 | NR          | 1170 | 1170 | 1170 | 1170 | 1345 | 1345 | 1345 | NR   |
| ASPT42C1 | NR          | 1170 | 1170 | 1170 | 1170 | 1345 | 1345 | 1345 | NR   |
| ASPT48C1 | NR          | 1170 | 1170 | 1170 | 1170 | 1345 | 1345 | 1345 | NR   |
| ASPT42D1 | NR          | 1590 | 1590 | 1590 | 1590 | 1715 | NR   | 1715 | NR   |
| ASPT48D1 | NR          | 1590 | 1590 | 1590 | 1590 | 1715 | NR   | 1715 | 1715 |
| ASPT60D1 | NR          | 1590 | 1590 | 1590 | 1590 | 1715 | NR   | 1715 | 1715 |

MINIMUM CFM REQUIRED FOR HEATER KITS

# ACCESSORIES

## AVPTC\*\*14\*\*

| Heat Kit Applications | AVPTC        |          |          |          |          |           |            |             |
|-----------------------|--------------|----------|----------|----------|----------|-----------|------------|-------------|
|                       | Type / Model | 24B14-A* | 30C14-A* | 36C14-A* | 48C14-A* | 42D14-A*† | 48D14-A*†† | 60D14-A*††† |
| HKSX03XC              | X            | X        |          |          |          | X         |            |             |
| HKSX05XC              | X            | X        | X        | X        | X        | X         | X          | X           |
| HKSX06XC              | X            | X        | X        | X        | X        | X         | X          | X           |
| HKSX08XC              | X            | X        | X        | X        | X        | X         | X          | X           |
| HKSX10XC              | X            | X        | X        | X        | X        | X         | X          | X           |
| HKSX15XF*             |              |          | X        | X        | X        | X         | X          | X           |
| HKSX20XF*             |              |          | X        | X        | X        | X         | X          | X           |
| HKSC05XC              | X            | X        | X        | X        | X        | X         | X          | X           |
| HKSC08XC              | X            | X        | X        | X        | X        | X         | X          | X           |
| HKSC10XC              | X            | X        | X        | X        | X        | X         | X          | X           |
| HKSC15XA              |              |          | X        | X        | X        | X         | X          | X           |
| HKSC15XB              |              |          | X        | X        | X        | X         | X          | X           |
| HKSC15XF*             |              |          | X        | X        | X        | X         | X          | X           |
| HKSC19CA*             |              |          | X        | X        |          |           |            |             |
| HKSC19CB*             |              |          | X        | X        |          |           |            |             |
| HKSC20DA              |              |          |          |          |          | X         | X          | X           |
| HKSC20DB              |              |          |          |          |          | X         | X          | X           |
| HKSCX20XF*            |              |          | X        | X        | X        | X         | X          | X           |
| HKSC25DC*             |              |          |          |          |          |           | X          | X           |

\* Revision level that may or may not be designated.

Refer to the minimum airflow requirements for each of the heat kits.

†For match up with a 2 ton outdoor unit: Heater kit application shall not exceed 10 kW.

Airflow for 5 kW up to 10 kW heater kits shall be set to 850 cfm speed tap of ON-ON-ON.

††For match up with a 3 ton outdoor unit: Heater kit application shall not exceed 15 kW.

Airflow for 5 kW up to 15 kW heater kits shall be set to 1400 cfm speed tap of ON-ON-OFF.

†††For match up with a 3.5 ton outdoor unit: Heater kit application shall not exceed 20 kW.

Airflow for 5 kW up to 20 kW heater kits shall be set to 1620 cfm speed tap of ON-ON-OFF

\*\* 3 kW heater kit is not applicable for this indoor application.

| Heater kit (Kw)           |       |      |      |      |      |      |      |      |          |
|---------------------------|-------|------|------|------|------|------|------|------|----------|
|                           | 3     | 5    | 6    | 8    | 10   | 15   | 19   | 20   | 21 or 25 |
| AVPTC24B14                | 550   | 650  | 700  | 800  | 850  | NR   | NR   | NR   | NR       |
| AVPTC30C14                | 600   | 700  | 750  | 875  | 950  | NR   | NR   | NR   | NR       |
| AVPTC36C14                | NR    | 850  | 900  | 1000 | 1200 | 1440 | 1500 | 1500 | NR       |
| AVPTC48C14                | NR    | 850  | 900  | 1000 | 1200 | 1440 | 1500 | 1500 | NR       |
| AVPTC42D14 <sup>†</sup>   | 850** | 1250 | 1300 | 1500 | 1550 | 1720 | NR   | 1800 | NR       |
| AVPTC48D14 <sup>††</sup>  | NR    | 1250 | 1300 | 1500 | 1550 | 1720 | NR   | 1815 | 1850     |
| AVPTC60D14 <sup>†††</sup> | NR    | 1250 | 1300 | 1500 | 1550 | 1780 | NR   | 1850 | 1850     |

MINIMUM CFM REQUIRED FOR HEATER KITS, See notes below

Note: Airflow data shown applies to the electric heat only in either legacy mode or communicating mode operation

NR - Not rated

\* Within thermostat user menu CTK0\* communicating thermostat will display 20KW for OFF- OFF- ON dip switch selection, 21kW for

†For match up with a 2 ton outdoor unit: Heater kit application shall not exceed 10 kW.

Airflow for 5 kW up to 10 kW heater kits shall be set to 850 cfm speed tap of ON-ON-ON.

††For match up with a 3 ton outdoor unit: Heater kit application shall not exceed 15 kW.

Airflow for 5 kW up to 15 kW heater kits shall be set to 1300 cfm speed tap of ON-OFF-ON.

†††For match up with a 3.5 ton outdoor unit: Heater kit application shall not exceed 20 kW.

Airflow for 5 kW up to 20 kW heater kits shall be set to 1500 cfm speed tap of ON-OFF-OFF

# ACCESSORIES

READY 2015

## ARUF & ASPT READY 2015

| MODEL LIST FOR DOWNFLOW KIT |                       |                       |
|-----------------------------|-----------------------|-----------------------|
| DFK-B<br>DOWNFLOW KIT       | DFK-C<br>DOWNFLOW KIT | DFK-D<br>DOWNFLOW KIT |
| ARUF25B14**                 | ARUF37C14**           | ARUF37D14**           |
| ARUF29B14**                 | ARUF43C14**           | ARUF43D14**           |
| ARUF31B14**                 | ARUF49C14**           | ARUF47D14**           |
|                             |                       | ARUF49D14**           |
|                             |                       | ARUF61D14**           |
|                             |                       | ASPT61D14**           |

| MODEL     | HEATER KIT (KW) |      |      |      |      |      |      |      |      |
|-----------|-----------------|------|------|------|------|------|------|------|------|
|           | 3               | 5    | 6    | 8    | 10   | 15   | 19   | 20   | 25   |
| ARUF25B14 | 715             | 715  | 715  | 715  | 950  |      |      |      |      |
| ARUF29B14 | 715             | 715  | 715  | 715  | 950  |      |      |      |      |
| ARUF31B14 | 715             | 715  | 715  | 715  | 875  | 875  |      |      |      |
| ARUF37C14 |                 | 1170 | 1170 | 1170 | 1170 | 1345 | 1345 |      |      |
| ARUF43C14 |                 | 1170 | 1170 | 1170 | 1170 | 1345 | 1345 |      |      |
| ARUF49C14 |                 | 1170 | 1170 | 1170 | 1170 | 1340 | 1430 |      |      |
| ARUF37D14 |                 | 1170 | 1170 | 1170 | 1170 | 1345 |      | 1345 |      |
| ARUF43D14 |                 | 1170 | 1170 | 1170 | 1170 | 1345 |      | 1345 |      |
| ARUF47D14 |                 | 1170 | 1170 | 1170 | 1170 | 1345 |      | 1345 |      |
| ARUF49D14 |                 | 1240 | 1240 | 1240 | 1240 | 1520 |      | 1520 |      |
| ARUF61D14 |                 | 1590 | 1590 | 1590 | 1590 | 1715 |      | 1715 | 1715 |
| ASPT61D14 |                 | 1590 | 1590 | 1590 | 1590 | 1715 |      | 1715 | 1715 |

# PRODUCT DESIGN

This section gives a basic description of cooling unit operation, its various components and their basic operation. Ensure your system is properly sized for heat gain and loss according to methods of the Air Conditioning Contractors Association (ACCA) or equivalent.

## CONDENSING UNIT

The condenser air is pulled through the condenser coil by a direct drive propeller fan. This condenser air is then discharged out of the top of the cabinet. These units are designed for free air discharge, so no additional resistance, like duct work, shall be attached.

The suction and liquid line connections on present models are of the sweat type for field piping with refrigerant type copper. Front seating valves are factory installed to accept the field run copper. The total refrigerant charge for a normal installation is factory installed in the condensing unit.

GSX, GSZ, ASX, ASZ, SSX, SSZ, DSX, DSZ, VSX, and VSZ models are available in 1 1/2 through 5 ton sizes and use R-410A refrigerant. They are designed for 208/230 volt single phase applications.

GSX/GSZ \*\*\*\*\*2 models are available in 2 and 3 ton sizes and use R-410A refrigerant. They are designed for 220/240 volt single phase applications.

GSX/GSZ \*\*\*\*\*3 models are available in 3, 4, and 5 ton sizes and use R-410A refrigerant. They are designed for 208/230 volt 3-phase applications.

GSX/GSZ \*\*\*\*\*4 models are available in 3, 4, and 5 ton sizes and use R-410A refrigerant. They are designed for 380/420 volt 3-phase applications.

GSX/GSZ \*\*\*\*\*5 models are available in 3, 4, and 5 ton sizes and use R-410A refrigerant. They are designed for 380/420 volt 3-phase applications.

ASX, ASZ, DSX and DSZ R-410A model units use the Copeland Scroll "Ultratech" Series compressors which are specifically designed for R-410A refrigerant. These units also have Copeland® ComfortAlert diagnostics.

GSX, GSZ, SSX, SSZ, VSX, and VSZ R-410A model units, except for GSX130181C\*, VSX130181B\*, VSX130241E\*, VSX130421B\*, and VSX130481B\*, use the Copeland Scroll "Ultratech" Series compressors which are specifically designed for R-410A refrigerant.

ASXC, ASZC, DSXC, DSZC models are available in 2 through 5 ton sizes and use R-410A refrigerant. They are designed for 208/230 volt single phase applications.

ASXC, ASZC, DSXC, DSZC R-410A model units use the Copeland Scroll "Ultratech" Series compressors which are specifically designed for R-410A refrigerant. These units also have Copeland® ComfortAlert diagnostics. The Copeland® ComfortAlert diagnostics are integrated into the unitary (UC) control. These models are ComfortNet™ ready.

There are a number of design characteristics which are different from the traditional reciprocating and/or scroll compressors.

"Ultratech" Series scroll compressors will not have a discharge thermostat. Some of the early model scroll compressors required discharge thermostat.

"Ultratech" Series scroll compressors use "POE" or polyolester oil which is **NOT** compatible with mineral oil based lubricants like 3GS. "POE" oil must be used if additional oil is required.

## COILS AND BLOWER COILS - LEGACY MODELS

MBR/MBE/MBVC blower cabinets are designed to be used as a two-piece blower and coil combination. MBR/MBE/MBVC blower sections can be attached to cased evaporator coil. This two-piece arrangement allows for a variety of mix-matching possibilities providing greater flexibility. The MBE/MBVC blower cabinets use a variable speed motor that maintains a constant airflow with a higher duct static.

MBE/MBVC blower cabinets are approved for applications with cooling coils of up to 0.8 inches W.C. external static pressure. The MBE models includes a feature that allows airflow to be changed by +10% or -15%. The MBVC models allow airflow trimming of +/-10%.

The MBR blower cabinet uses a PSC motor. It is approved for applications with cooling coils of up to 0.5 inches W.C. external static pressure.

The MBR/MBE/MBVC blower cabinets with proper coil matches can be positioned for upflow, counterflow, horizontal right or horizontal left operation. All units are constructed with R-4.2 insulation. In areas of extreme humidity (greater than 80% consistently), insulate the exterior of the blower with insulation having a vapor barrier equivalent to ductwork insulation, providing local codes permit.

The CAUF, CAPF and CAPT coils are designed for upflow and counterflow applications. The CACF and CHPF coils are designed for horizontal applications.

## Communicating Unitary Control (UC) PCB

The Communicating System Unitary Control PCB is a micro-processor-based control for heat pump and air conditioning condensing units with single-phase compressors up to 5 ton capacity operating on standard residential or Delta and Wye commercial power. The control incorporates the basic functionality of existing defrost controls, outdoor thermostats, contactors, compressor staging controls, short cycle controls, line voltage monitors, Comfort Alert™ or CoreSense Module (dependent upon which module you are using), two speed condenser fan relays and the Active Protection component of enabled thermostats. The control is designed to work as part of a fully communicating HVAC system with 4 wires. The control also supports legacy 24VAC thermostat inputs for Y1, Y2, O and 24VAC outputs for RVS, W1, and L for non-communicating systems. Outputs include compressor power, compressor stage select, and outdoor fan high and outdoor fan low speed. System inputs include high/low pressure switches, as well as thermistor inputs for outdoor coil temperature and outdoor air temperature.

# PRODUCT DESIGN

The ASX & ASXC [16 & 18], ASZ & ASZC [16 & 18], DSX & DSXC [16 & 18] and DSZ & DSZC [16 & 18] series split system units use a two-stage scroll compressor. The two-step modulator has an internal unloading mechanism that opens a bypass port in the first compression pocket, effectively reducing the displacement of the scroll. The opening and closing of the bypass port is controlled by an internal electrically operated solenoid.

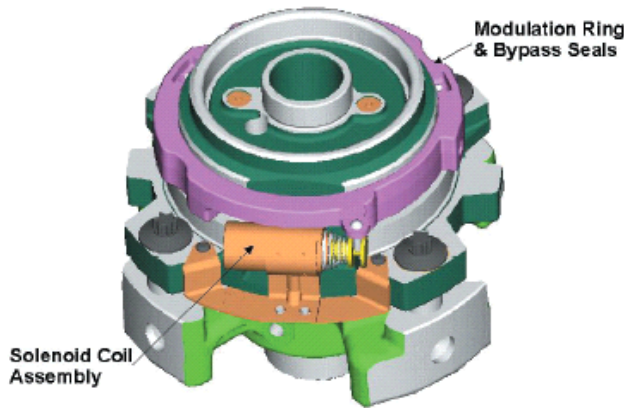

The ZPS/ZRS two-step modulated scroll uses a single step of unloading to go from full capacity to approximately 67% capacity. A single speed, high efficiency motor continues to run while the scroll modulates between the two capacity steps.

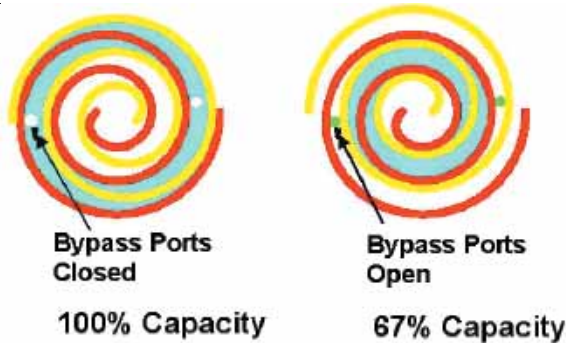
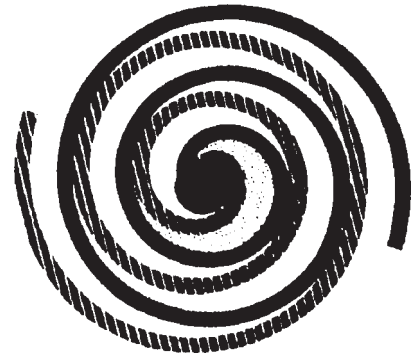

FIGURE A

A scroll is an involute spiral which, when matched with a mating scroll form as shown, generates a series of crescent shaped gas pockets between the two members.

During compression, one scroll remains stationary (fixed scroll) while the other form (orbiting scroll) is allowed to orbit (but not rotate) around the first form.



As this motion occurs, the pockets between the two forms are slowly pushed to the center of the two scrolls while simultaneously being reduced in volume. When the pocket reaches the center of the scroll form, the gas, which is now at a high pressure, is discharged out of a port located at the center.

During compression, several pockets are being compressed simultaneously, resulting in a very smooth process. Both the suction process (outer portion of the scroll members) and the discharge process (inner portion) are continuous.

Some design characteristics of the Compliant Scroll compressor are:

- Compliant Scroll compressors are more tolerant of liquid refrigerant.
- **NOTE:** Even though the compressor section of a Scroll compressor is more tolerant of liquid refrigerant, continued floodback or flooded start conditions may wash oil from the bearing surfaces causing premature bearing failure.
- "Ultratech" Series scroll compressors use "POE" or polyolester oil which is **NOT** compatible with mineral oil based lubricants like 3GS. "POE" oil must be used if additional oil is required.
- Compliant scroll compressors perform "quiet" shutdowns that allow the compressor to restart immediately without the need for a time delay. This compressor will restart even if the system has not equalized.

**NOTE:** Operating pressures and amp draws may differ from standard reciprocating compressors. This information can be found in the unit's Technical Information Manual.

# PRODUCT DESIGN

## CAPACITY CONTROL - LEGACY MODELS

During the compression process, there are several pockets within the scroll that are compressing gas. Modulation is achieved by venting a portion of the gas in the first suction pocket back to the low side of the compressor thereby reducing the effective displacement of the compressor. See Figure A. Full capacity is achieved by blocking these vents, increasing the displacement to 100%. A solenoid in the compressor, controlled by an external 24-volt ac signal, moves the slider ring that covers and uncovers these vents. The vent covers are arranged in such a manner that the compressor operates somewhere around 67% capacity when the solenoid is not energized and 100% capacity when the solenoid is energized. The loading and unloading of the two step scroll is done “on the fly” without shutting off the motor between steps. See Figure B below. The unloaded mode default was chosen for two reasons:

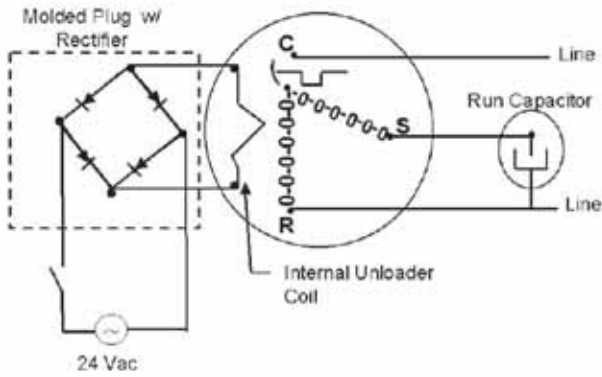

FIGURE B

1. It is expected that the majority of run hours will be in the low capacity, unloaded mode.
2. It allows a simple two-stage thermostat to control capacity through the second stage in both cooling and possibly heating if desired.

## UNLOADER SOLENOID

A nominal 24-volt direct current coil activates the internal unloader solenoid. The input control circuit voltage must be 18 to 28 volt ac. The coil power requirement is 20 VA. The external electrical connection is made with a molded plug assembly. This plug is connected to the Comfort Alert™ or CoreSense™ Module (dependent upon which module you are using) which contains a full wave rectifier to supply direct current to the unloader coil.

## CAPACITY CONTROL - COMFORTNET™ MODELS

During the compression process, there are several pockets within the scroll that are compressing gas. Modulation is achieved by venting a portion of the gas in the first suction pocket back to the low side of the compressor thereby reducing the effective displacement of the compressor. See Figure A. Full capacity is achieved by blocking these vents, increasing the displacement to 100%. A solenoid in the compressor, controlled by an external 24-volt ac signal, moves the slider ring that covers and uncovers these vents. The vent covers are arranged in such a manner that the compressor operates somewhere around 67% capacity when the solenoid is not energized and 100% capacity when the solenoid is energized. The loading and unloading of the two step scroll is done “on the fly” without shutting off the motor between steps. See Figure C below. The unloaded mode default was chosen for two reasons:

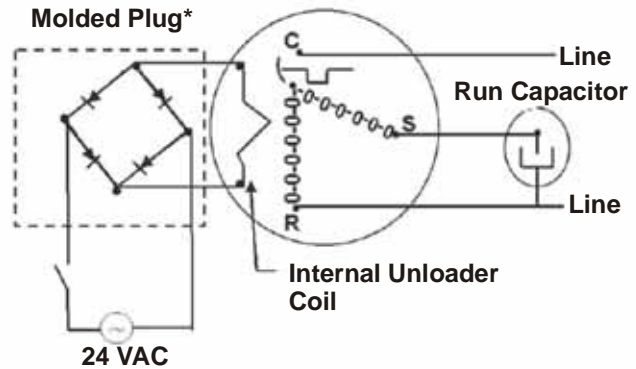

\*Rectifier is integrated on the UC PCB

FIGURE C

1. It is expected that the majority of run hours will be in the low capacity, unloaded mode.
2. It allows a simple two-stage thermostat to control capacity through the second stage in both cooling and possibly heating if desired.

## UNLOADER SOLENOID

A nominal 24-volt direct current coil activates the internal unloader solenoid. The input control circuit voltage must be 18 to 28 volt ac. The coil power requirement is 20 VA. The external electrical connection is made with a molded plug assembly. This plug is connected to the Communicating Unitary Control PCB (UC PCB) which contains a full wave rectifier to supply direct current to the unloader coil.

# SYSTEM OPERATION

## COOLING

The refrigerant used in the system is R-410A. It is a clear, colorless, non-toxic and non-irritating liquid. R-410A is a 50:50 blend of R-32 and R-125. The boiling point at atmospheric pressure is **-62.9°F**.

A few of the important principles that make the refrigeration cycle possible are: heat always flows from a warmer to a cooler body. Under lower pressure, a refrigerant will absorb heat and vaporize at a low temperature. The vapors may be drawn off and condensed at a higher pressure and temperature to be used again.

The indoor evaporator coil functions to cool and dehumidify the air conditioned spaces through the evaporative process taking place within the coil tubes.

**NOTE:** The pressures and temperatures shown in the refrigerant cycle illustrations on the following pages are for demonstration purposes only. Actual temperatures and pressures are to be obtained from the "Expanded Performance Chart".

Liquid refrigerant at condensing pressure and temperatures, (270 psig and 122°F), leaves the outdoor condensing coil through the drier and is metered into the indoor coil through the metering device. As the cool, low pressure, saturated refrigerant enters the tubes of the indoor coil, a portion of the liquid immediately vaporizes. It continues to soak up heat and vaporizes as it proceeds through the coil, cooling the indoor coil down to about 48°F.

Heat is continually being transferred to the cool fins and tubes of the indoor evaporator coil by the warm system air. This warming process causes the refrigerant to boil. The heat removed from the air is carried off by the vapor.

As the vapor passes through the last tubes of the coil, it becomes superheated. That is, it absorbs more heat than is necessary to vaporize it. This is assurance that only dry gas will reach the compressor. Liquid reaching the compressor can weaken or break compressor valves.

The compressor increases the pressure of the gas, thus adding more heat, and discharges hot, high pressure superheated gas into the outdoor condenser coil.

In the condenser coil, the hot refrigerant gas, being warmer than the outdoor air, first loses its superheat by heat transferred from the gas through the tubes and fins of the coil. The refrigerant now becomes saturated, part liquid, part vapor and then continues to give up heat until it condenses to a liquid alone. Once the vapor is fully liquefied, it continues to give up heat which subcools the liquid, and it is ready to repeat the cycle.

## HEATING

The heating portion of the refrigeration cycle is similar to the cooling cycle. By energizing the reversing valve solenoid coil, the flow of the refrigerant is reversed. The indoor coil now becomes the condenser coil, and the outdoor coil becomes the evaporator coil.

The check valve at the indoor coil will open by the flow of refrigerant letting the now condensed liquid refrigerant bypass the indoor expansion device. The check valve at the outdoor coil will be forced closed by the refrigerant flow, thereby utilizing the outdoor expansion device.

The restrictor orifice used with the CA\*F, CHPF and CH\*\*FCB coils will be forced onto a seat when running in the cooling cycle, only allowing liquid refrigerant to pass through the orifice opening. In the heating cycle, it will be forced off the seat allowing liquid to flow around the restrictor. A check valve is not required in this circuit.

## COOLING CYCLE

For legacy room thermostat: When the room thermostat calls for cool, the contacts of the room thermostat close making terminals R to Y1 & G (if thermostat calls for low stage cool), or R to Y1, Y2 & G (if thermostat calls for high stage cool), the low voltage circuit of the transformer is completed. Current now flows through the magnetic holding coils of the compressor contactor (CC) and fan relay (RFC). If thermostat calls for high stage cool, the microprocessor on the UC board will also energize the compressor high stage solenoid to run the compressor at full capacity.

This draws in the normally open contact CC, starting the compressor and condenser fan motors in either low or high stage depending on the thermostat's demand. At the same time, contacts RFC close, starting the indoor fan motor.

When the thermostat is satisfied, it opens its contacts, breaking the low voltage circuit, causing the compressor contactor and indoor fan relay to open, shutting down the system.

If the room thermostat fan selector switch should be set on the "on" position, then the indoor blower would run continuously rather than cycling with the compressor.

GSZ, ASZ, SSZ, DSZ, and VSZ models energize the reversing valve thorough the "O" circuit in the room thermostat. Therefore, the reversing valve remains energized as long as the thermostat subbase is in the cooling position. The only exception to this is during defrost.

For heat pumps, during cooling cycle the reversing valve is energized as the room thermostat closes "O" terminal to R and the microprocessor on the UC board responds to such a condition by energizing the solenoid coil on the reversing valve.

For communicating room thermostat: When the room thermostat calls for either low stage cool or high stage cool, appropriate commands are sent via the data 1 and data 2 lines to the outdoor unit's UC control. The UC control energizes the on-board compressor relay and the on-board outdoor fan relay. The compressor high stage solenoid is energized if it is a high stage call.

The UC control sends a fan command to the indoor unit (air handler or furnace). The indoor unit operates the indoor blower at the appropriate airflow level. The system operates at the cooling level demanded by the thermostat.

# SYSTEM OPERATION

When the thermostat is satisfied, appropriate commands are sent to the UC control. The compressor relay and outdoor fan relay is de-energized. The compressor high stage solenoid is de-energized if it was energized. The UC control sends an appropriate command to the indoor unit to de-energize the indoor blower motor.

If room thermostat fan status is set to be “on”, then indoor blower would run continuously rather than cycling with the compressor.

For heat pumps, the reversing valve is energized during a cooling cycle. The call for cooling from the communicating thermostat indicates to the control that the reversing valve is to be energized during cooling operation.

## **DEFROST CYCLE - LEGACY MODELS**

The defrosting of the outdoor coil is jointly controlled by the defrost control board and the defrost thermostat.

### ***Solid State Defrost Control***

During operation the power to the circuit board is controlled by a temperature sensor, which is clamped to a return bend (3/8" coils) or a feeder tube (5 mm coils) entering the outdoor coil. Defrost timing periods of 30, 60, or 90 minutes may be selected by connecting the circuit board jumper to 30, 60, or 90 respectively. Accumulation of time for the timing period selected starts when the sensor closes (approximately 31° F), and when the room thermostat calls for heat. At the end of the timing period, the unit's defrost cycle will be initiated provided the sensor remains closed. When the sensor opens (approximately 75° F), the defrost cycle is terminated and the timing period is reset. If the defrost cycle is not terminated due to the sensor temperature, a ten minute override interrupts the unit's defrost period. The new upgraded defrost control has a 12 minute override interrupt.

## **DEFROST CYCLE - COMFORTNET™ MODELS**

The defrosting of the outdoor coil is jointly controlled by the UC PCB and the outdoor coil temperature (OCT) sensor.

The OCT sensor is clamped to a feeder tube entering the outdoor coil. Defrost timing periods of 30, 60, 90 or 120 minutes may be selected via the dipswitch settings on the UC PCB. In a communicating system, the defrost timing periods can also be selected in the communicating thermostat user menu. During operation the microprocessor on the UC checks coil temperature via the OCT sensor every 30, 60, 90, or 120 minutes when there is a call for heating. If by the time the microprocessor checks the coil temperature, and it's low enough (approximately 31°F), and if there is a call for heat from the thermostat, the PCB will initiate a defrost. When the microprocessor detects the coil temperature to be high enough (approximately 75 °F), or 10 minutes of maximum defrost cycle time has elapsed, whichever occurs first, the defrost cycle is terminated and the timing period is reset. The field service personnel can also advance a heat pump to the defrost cycle by simultaneously pressing the “TEST” button and the “RECALL” button on the UC board.

## **HEATING CYCLE**

The reversing valve on the GSZ, SSZ, ASZ and DSZ models is energized in the cooling cycle through the "O" terminal on the room thermostat.

These models have a 24 volt reversing valve coil. When the thermostat selector switch is set in the cooling position, the "O" terminal on the thermostat is energized all the time.

Care must be taken when selecting a room thermostat. Refer to the installation instructions shipped with the product for approved thermostats.

## **HEATING CYCLE**

For legacy room thermostat: When the room thermostat calls for heat, the contacts of the room thermostat close making terminals R to Y & G, the low voltage circuit of the transformer is completed. Current now flows through the magnetic holding coils of the compressor contactor (CC) and fan relay (RFC).

This draws in the normally open contact CC, starting the compressor condenser fan motors. At the same time, contacts RFC close, starting the indoor fan motor.

When the thermostat is satisfied, it opens its contacts, breaking the low voltage circuit, causing the compressor contactor and indoor fan relay to open, shutting down the system.

If the room thermostat fan selector switch should be set to the “on” position, then the indoor blower would run continuously rather than cycling with the compressor.

For communicating room thermostat: When the room thermostat calls for either low stage heat or high stage heat, appropriate commands are sent via the data 1 and data 2 lines to the outdoor unit's UC control. The UC control energizes the on-board compressor relay and the on-board outdoor fan relay. The compressor high stage solenoid is energized if it is a high stage call. The UC control sends a fan command to the indoor unit (air handler or furnace). The indoor unit operates the indoor blower at the appropriate airflow level. The system operates at the cooling level demanded by the thermostat.



# SYSTEM OPERATION

## COOLING CYCLE

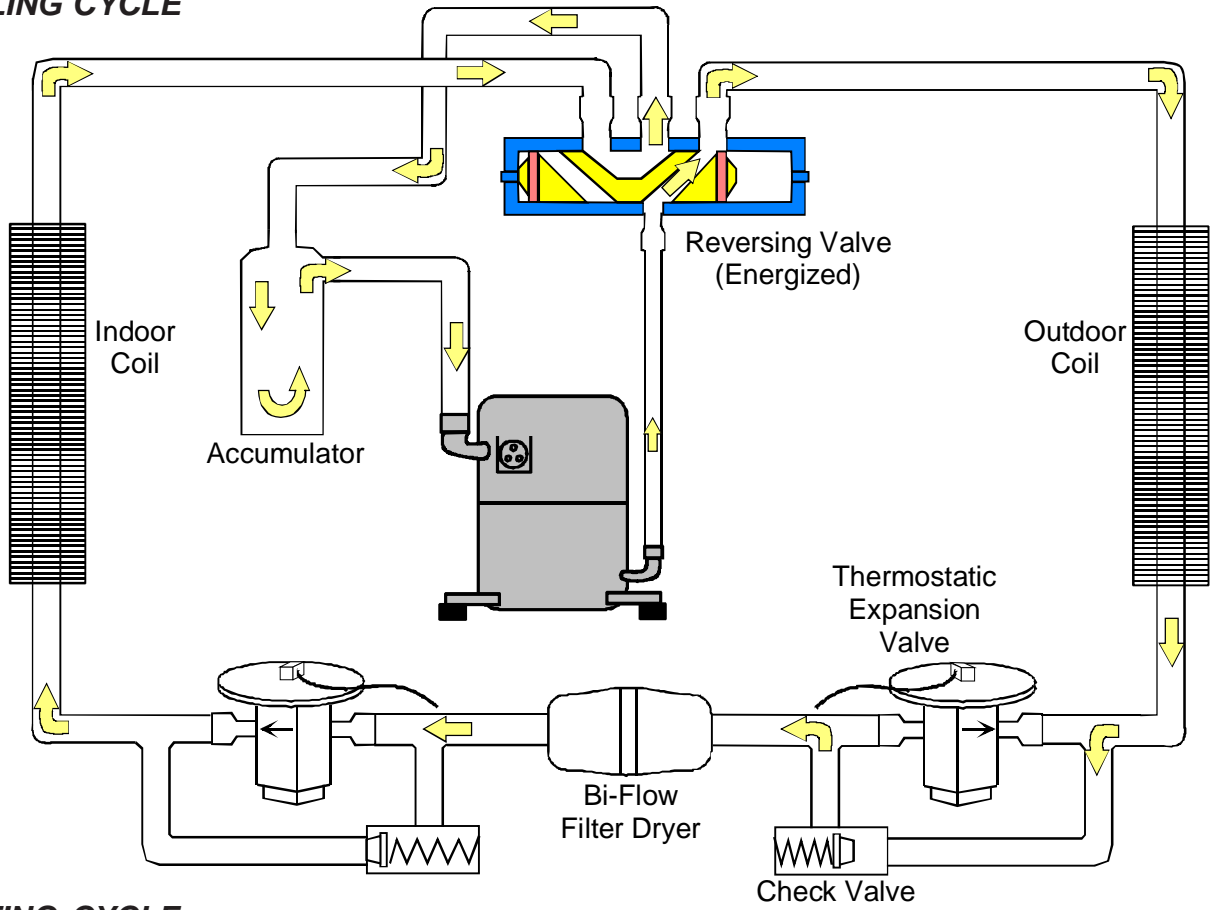

## HEATING CYCLE

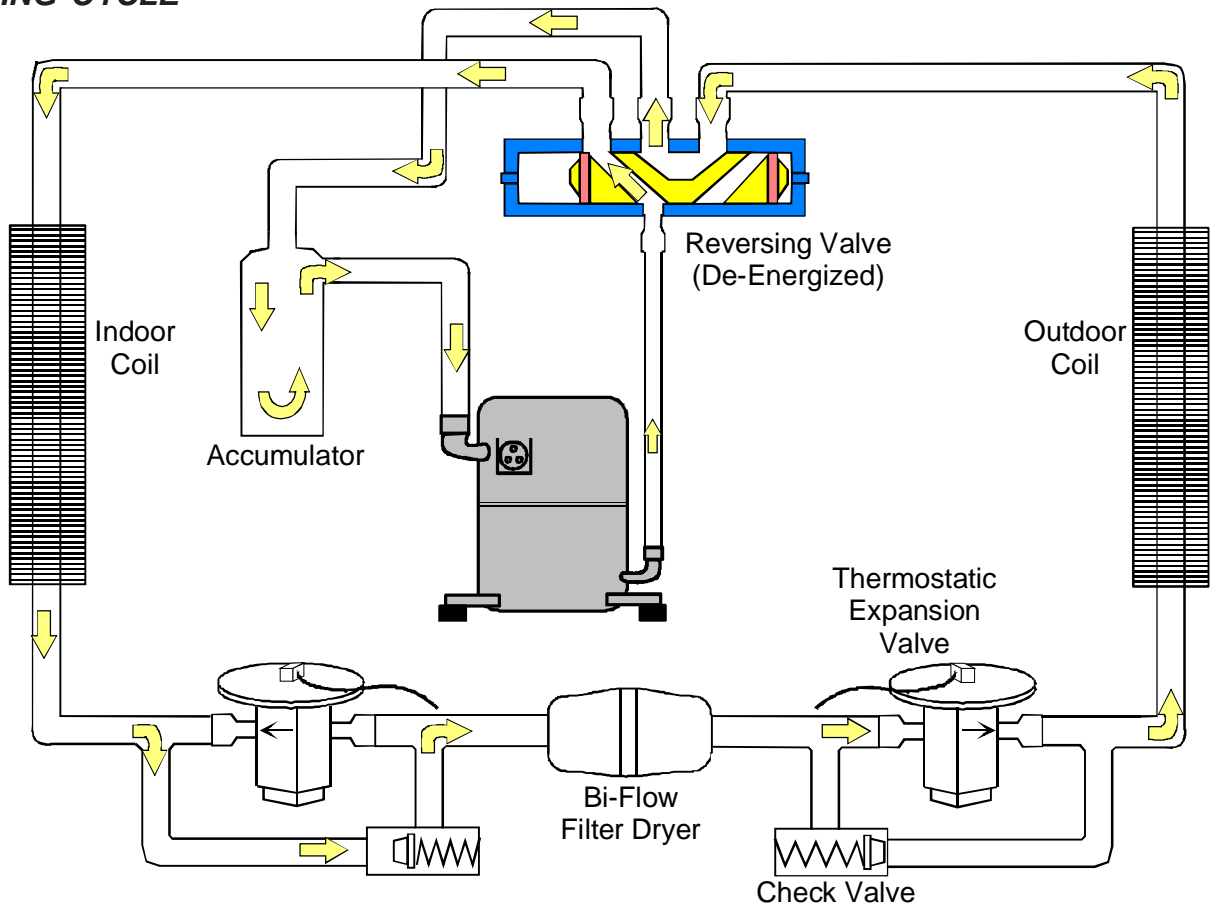

# SYSTEM OPERATION

**EXPANSION VALVE/CHECK VALVE ASSEMBLY  
IN COOLING OPERATION**

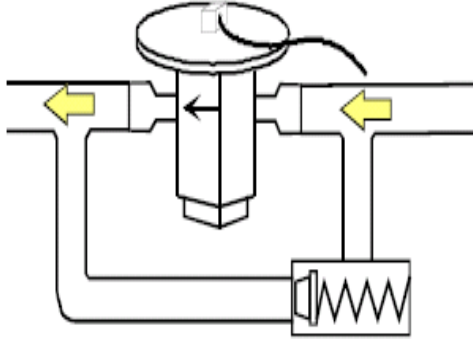

**EXPANSION VALVE/CHECK VALVE ASSEMBLY  
IN HEATING OPERATION**

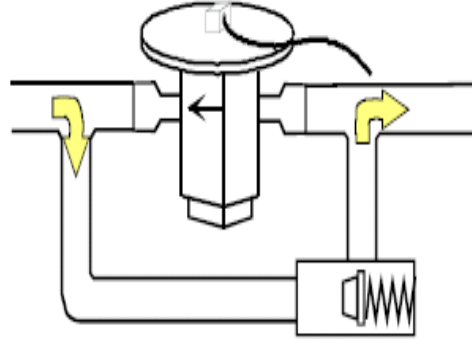

Most expansion valves used in current Amana® Brand Heat Pump products use an internally checked expansion valve. This type of expansion valve does not require an external check valve as shown above. However, the principle of operation is the same.

**RESTRICTOR ORIFICE ASSEMBLY  
IN COOLING OPERATION**

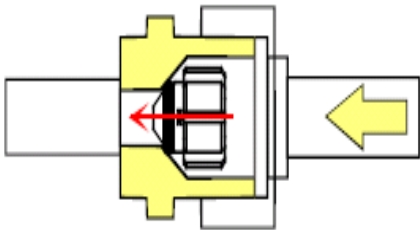

In the cooling mode, the orifice is pushed into its seat, forcing refrigerant to flow through the metered hole in the center of the orifice.

**RESTRICTOR ORIFICE ASSEMBLY  
IN HEATING OPERATION**

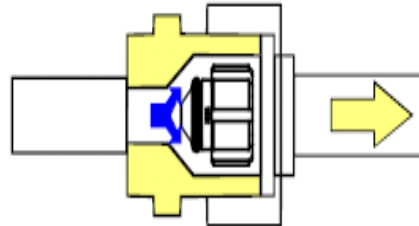

In the heating mode, the orifice moves back off its seat, allowing refrigerant to flow unmetered around the outside of the orifice.

# SYSTEM OPERATION

When the thermostat is satisfied, appropriate commands are sent to the UC control. The compressor relay and outdoor fan relay is de-energized. The compressor high stage solenoid is de-energized if it was energized. The UC control sends an appropriate command to the indoor unit to de-energize the indoor blower motor.

## AFE18-60A CONTROL BOARD



### DESCRIPTION

The AFE18 control is designed for use in heat pump applications where the indoor coil is located above/downstream of a gas or fossil fuel furnace. It will operate with single and two stage heat pumps and single and two stage furnaces. The AFE18 control will turn the heat pump unit off when the furnace is turned on. An anti-short cycle feature is also incorporated which initiates a 3 minute timed off delay when the compressor goes off. On initial power up or loss and restoration of power, this 3 minute timed off delay will be initiated. The compressor won't be allowed to restart until the 3 minute off delay has expired. Also included is a 5 second de-bounce feature on the "Y, E, W1 and O" thermostat inputs. These thermostat inputs must be present for 5 seconds before the AFE18 control will respond to it.

An optional outdoor thermostat, OT18-60A, can be used with the AFE18 to switch from heat pump operation to furnace

operation below a specific ambient temperature setting, i.e. break even temperature during heating. When used in this manner, the "Y" heat demand is switched to the "W1" input to the furnace by the outdoor thermostat and the furnace is used to satisfy the first stage "Y" heat demand. On some controls, if the outdoor thermostat fails closed in this position during the heating season, it will turn on the furnace during the cooling season on a "Y" cooling demand. In this situation, the furnace produces heat and increases the indoor temperature thereby never satisfying the cooling demand. The furnace will continue to operate and can only be stopped by switching the thermostat to the off position or removing power to the unit and then replacing the outdoor thermostat. **When the AFE18 receives a "Y" and "O" input from the indoor thermostat**, it recognizes this as a cooling demand in the cooling mode. If the outdoor thermostat is stuck in the closed position switching the "Y" demand to the "W1" furnace input during the cooling mode as described above, the AFE18 won't allow the furnace to operate. The outdoor thermostat will have to be replaced to restore the unit to normal operation.

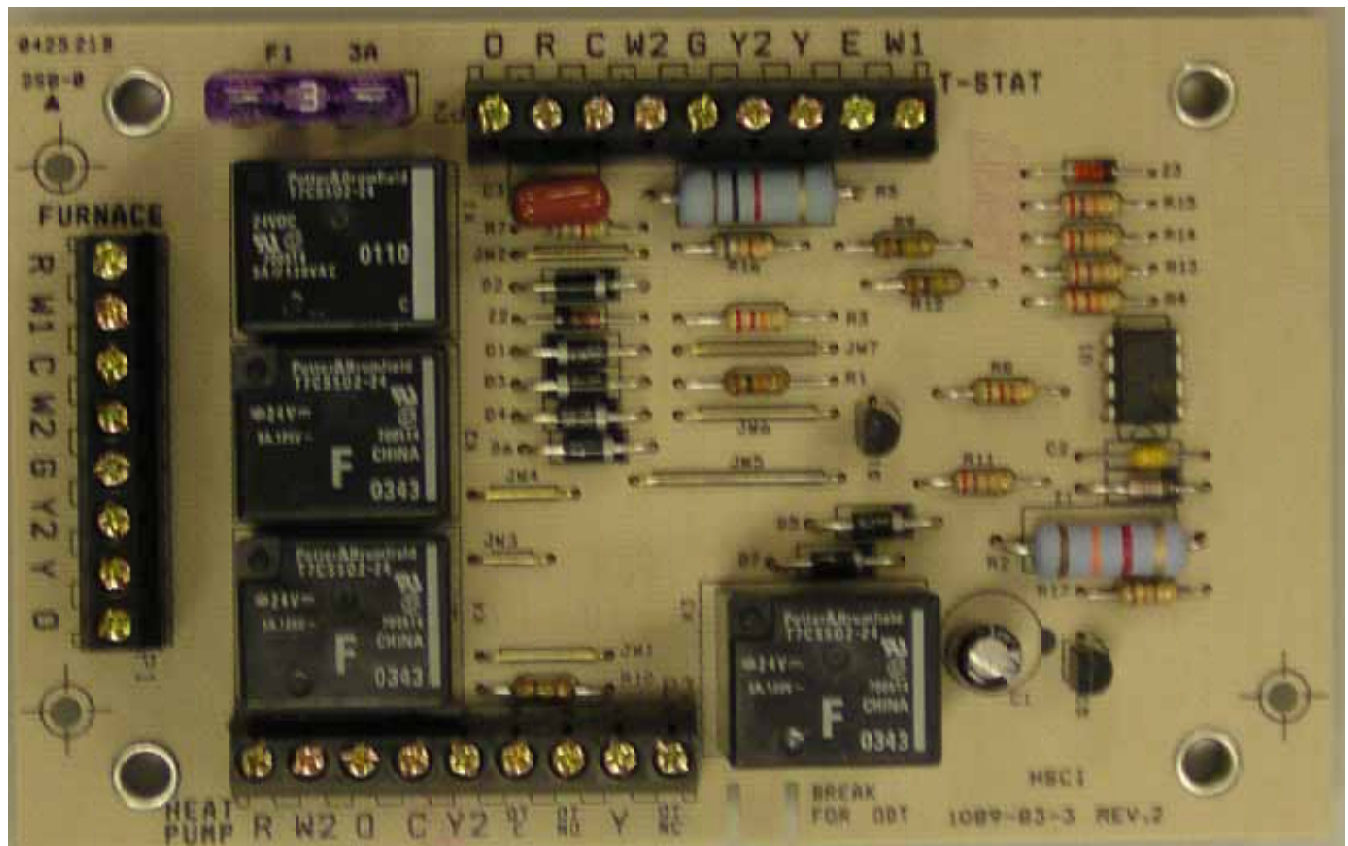
**⚠ WARNING**  
**HIGH VOLTAGE!**  
Disconnect ALL power before servicing or installing. Multiple power sources may be present. Failure to do so may cause property damage, personal injury or death.



# TROUBLESHOOTING CHART

## COOLING/HP ANALYSIS CHART

| Complaint                             | No Cooling |                       |                                      |                                    |                               |                              |  | Unsatisfactory Cooling/Heating |   |                            |                              |   |                     |   | System Operating Pressures      |                       |                      |                   | Test Method Remedy  | See Service Procedure Ref.                     |                       |
|---------------------------------------|------------|-----------------------|--------------------------------------|------------------------------------|-------------------------------|------------------------------|--|--------------------------------|---|----------------------------|------------------------------|---|---------------------|---|---------------------------------|-----------------------|----------------------|-------------------|---------------------|--|-----------------------|
|                                       | SYMPTOM    | System will not start | Compressor will not start - fan runs | Comp. and Cond. Fan will not start | Evaporator fan will not start | Condenser fan will not start | Compressor runs - goes off on overload | Compressor cycles on overload  | System runs continuously - little cooling/htg | Too cool and then too warm | Not cool enough on warm days | Certain areas too cool, others too warm | Compressor is noisy | System runs - blows cold air in heating | Unit will not terminate defrost | Unit will not defrost | Low suction pressure | Low head pressure |                     |  | High suction pressure |
| Power Failure                         | ●          |                       |                                      |                                    |                               |                              |  |                                |   |                            |                              |   |                     |   |                                 |                       |                      |                   |                     | Test Voltage                                   | S-1                   |
| Blown Fuse                            | ●          | ●                     | ●                                    |                                    |                               |                              |  |                                |   |                            |                              |   |                     |   |                                 |                       |                      |                   |                     | Inspect Fuse Size & Type                       | S-1                   |
| Unbalanced Power, 3PH                 |            | ●                     |                                      |                                    |                               | ●                            | ●                                      |                                |   |                            |                              |   |                     |   |                                 |                       |                      |                   |                     | Test Voltage                                   | S-1                   |
| Loose Connection                      | ●          |                       |                                      | ●                                  |                               | ●                            |  |                                |   |                            |                              |   |                     |   |                                 |                       |                      |                   |                     | Inspect Connection - Tighten                   | S-2, S-3              |
| Shorted or Broken Wires               | ●          | ●                     | ●                                    | ●                                  | ●                             | ●                            |  |                                |   |                            |                              |   |                     |   |                                 |                       |                      |                   |                     | Test Circuits With Ohmmeter                    | S-2, S-3              |
| Open Fan Overload                     |            |                       |                                      |                                    | ●                             |                              |  |                                |   |                            |                              |   |                     |   |                                 |                       |                      |                   |                     | Test Continuity of Overload                    | S-17A                 |
| Faulty Thermostat                     | ●          |                       | ●                                    | ●                                  |                               |                              |  | ●                              |   |                            |                              |   |                     |   |                                 |                       |                      |                   |                     | Test Continuity of Thermostat & Wiring         | S-3                   |
| Faulty Transformer                    | ●          | ●                     |                                      |                                    |                               |                              |  |                                |   |                            |                              |   |                     |   |                                 |                       |                      |                   |                     | Check Control Circuit with Voltmeter           | S-4                   |
| Shorted or Open Capacitor             |            | ●                     |                                      | ●                                  | ●                             | ●                            |  |                                |   |                            |                              |   |                     |   |                                 |                       |                      |                   |                     | Test Capacitor                                 | S-15                  |
| Internal Compressor Overload Open     |            | ●                     |                                      |                                    |                               |                              |  |                                |   |                            |                              |   | ◆                   |   |                                 |                       |                      |                   |                     | Test Continuity of Overload                    | S-17A                 |
| Shorted or Grounded Compressor        |            | ●                     |                                      |                                    |                               | ●                            |  |                                |   |                            |                              |   |                     |   |                                 |                       |                      |                   |                     | Test Motor Windings                            | S-17B                 |
| Compressor Stuck                      |            | ●                     |                                      |                                    |                               | ●                            |  |                                |   |                            |                              |   | ◆                   |   |                                 |                       |                      |                   |                     | Use Test Cord                                  | S-17D                 |
| Faulty Compressor Contactor           |            |                       | ●                                    |                                    | ●                             | ●                            |  |                                |   |                            |                              |   |                     |   |                                 |                       |                      |                   |                     | Test Continuity of Coil & Contacts             | S-7, S-8              |
| Faulty Fan Relay                      |            |                       |                                      | ●                                  |                               |                              |  |                                |   |                            |                              |   |                     |   |                                 |                       |                      |                   |                     | Test Continuity of Coil And Contacts           | S-7                   |
| Open Control Circuit                  |            |                       |                                      | ●                                  |                               |                              |  |                                |   |                            |                              |   |                     |   |                                 |                       |                      |                   |                     | Test Control Circuit with Voltmeter            | S-4                   |
| Low Voltage                           |            | ●                     |                                      |                                    |                               | ●                            | ●                                      |                                |   |                            |                              |   |                     |   |                                 |                       |                      |                   |                     | Test Voltage                                   | S-1                   |
| Faulty Evap. Fan Motor                |            |                       |                                      | ●                                  |                               |                              |  |                                |   |                            |                              |   |                     |   |                                 |                       | ●                    | ◆                 | Repair or Replace   | S-16   |                       |
| Shorted or Grounded Fan Motor         |            |                       |                                      |                                    | ●                             |                              |  |                                |   |                            |                              |   |                     |   |                                 |                       |                      |                   | ●                   | Test Motor Windings                            | S-16                  |
| Improper Cooling Anticipator          |            |                       |                                      |                                    |                               |                              | ●                                      | ●                              |   |                            |                              |   |                     |   |                                 |                       |                      |                   |                     | Check Resistance of Anticipator                | S-3B                  |
| Shortage of Refrigerant               |            |                       |                                      |                                    |                               |                              | ●                                      | ●                              |   |                            |                              |   | ◆                   |   |                                 | ●                     | ●                    |                   | ●                   | Test For Leaks, Add Refrigerant                | S-101, 103            |
| Restricted Liquid Line                |            |                       |                                      |                                    |                               |                              | ●                                      | ●                              |   |                            |                              |   |                     |   |                                 | ●                     | ●                    |                   | ●                   | Remove Restriction, Replace Restricted Part    | S-112                 |
| Open Element or Limit on Elec. Heater |            |                       |                                      |                                    |                               |                              |  |                                | ◆   |                            |                              |   | ◆                   |   |                                 |                       |                      |                   |                     | Test Heater Element and Controls               | S-26, S-27            |
| Dirty Air Filter                      |            |                       |                                      |                                    |                               |                              |  | ●                              | ●   | ●                          |                              |   |                     |   |                                 | ●                     |                      |                   | ◆                   | Inspect Filter-Clean or Replace                |                       |
| Dirty Indoor Coil                     |            |                       |                                      |                                    |                               |                              |  | ●                              | ●   | ●                          |                              |   |                     |   |                                 | ●                     |                      |                   | ◆                   | Inspect Coil - Clean                           |                       |
| Not enough air across Indoor Coil     |            |                       |                                      |                                    |                               |                              |  | ●                              | ●   | ●                          |                              |   |                     |   |                                 | ●                     |                      |                   | ◆                   | Check Blower Speed, Duct Static Press, Filter  | S-200                 |
| Too much air across Indoor Coil       |            |                       |                                      |                                    |                               |                              |  |                                |   |                            |                              |   |                     |   |                                 |                       | ◆                    | ●                 | Reduce Blower Speed | S-200  |                       |
| Overcharge of Refrigerant             |            |                       |                                      |                                    |                               | ●                            | ●                                      |                                |   |                            |                              | ●                                       | ◆                   |   |                                 |                       |                      | ●                 | ●                   | Recover Part of Charge                         | S-113                 |
| Dirty Outdoor Coil                    |            |                       |                                      |                                    |                               | ●                            | ●                                      |                                |   |                            | ●                            |   |                     |   |                                 |                       |                      | ◆                 | ●                   | Inspect Coil - Clean                           |                       |
| Noncondensibles                       |            |                       |                                      |                                    |                               |                              | ●                                      |                                |   | ●                          |                              |   | ◆                   |   |                                 |                       |                      |                   | ●                   | Recover Charge, Evacuate, Recharge             | S-114                 |
| Recirculation of Condensing Air       |            |                       |                                      |                                    |                               |                              | ●                                      |                                |   | ●                          |                              |   |                     |   |                                 |                       |                      |                   | ●                   | Remove Obstruction to Air Flow                 |                       |
| Infiltration of Outdoor Air           |            |                       |                                      |                                    |                               |                              | ●                                      |                                | ●   | ●                          |                              |   |                     |   |                                 |                       |                      |                   |                     | Check Windows, Doors, Vent Fans, Etc.          |                       |
| Improperly Located Thermostat         |            |                       |                                      |                                    | ●                             |                              |  |                                | ●   |                            |                              |   |                     |   |                                 |                       |                      |                   |                     | Relocate Thermostat                            |                       |
| Air Flow Unbalanced                   |            |                       |                                      |                                    |                               |                              |  |                                | ●   | ●                          |                              |   |                     |   |                                 |                       |                      |                   |                     | Readjust Air Volume Dampers                    |                       |
| System Undersized                     |            |                       |                                      |                                    |                               |                              |  | ●                              | ●   |                            |                              |   |                     |   |                                 |                       |                      |                   |                     | Refigure Cooling Load                          |                       |
| Broken Internal Parts                 |            |                       |                                      |                                    |                               |                              |  |                                |   |                            |                              | ●                                       | ◆                   |   |                                 |                       |                      |                   |                     | Replace Compressor                             | S-115                 |
| Broken Valves                         |            |                       |                                      |                                    |                               |                              |  |                                |   |                            |                              | ●                                       |                     |   |                                 |                       |                      | ●                 | ●                   | Test Compressor Efficiency                     | S-104                 |
| Inefficient Compressor                |            |                       |                                      |                                    |                               |                              |  |                                |   |                            |                              |   | ◆                   |   |                                 |                       |                      | ●                 | ●                   | Test Compressor Efficiency                     | S-104                 |
| Wrong Type Expansion Valve            |            |                       |                                      |                                    | ●                             | ●                            | ●                                      |                                | ●   |                            |                              |   |                     |   |                                 | ●                     | ●                    |                   | ◆                   | Replace Valve                                  | S-110                 |
| Expansion Device Restricted           |            |                       |                                      |                                    | ●                             | ●                            | ●                                      |                                | ●   |                            |                              |   |                     |   |                                 | ●                     | ●                    |                   | ●                   | Remove Restriction or Replace Expansion Device | S-110                 |
| Oversized Expansion Valve             |            |                       |                                      |                                    |                               |                              |  |                                |   |                            |                              |   |                     |   |                                 |                       |                      |                   | ●                   | Replace Valve                                  |                       |
| Undersized Expansion Valve            |            |                       |                                      |                                    | ●                             | ●                            | ●                                      |                                | ●   |                            |                              |   |                     |   |                                 |                       |                      |                   |                     | Replace Valve                                  |                       |
| Expansion Valve Bulb Loose            |            |                       |                                      |                                    |                               |                              |  |                                |   |                            |                              | ●                                       |                     |   |                                 |                       |                      |                   |                     | Tighten Bulb Bracket                           | S-105                 |
| Inoperative Expansion Valve           |            |                       |                                      |                                    | ●                             |                              |  | ●                              |   |                            |                              |   |                     |   |                                 |                       |                      | ●                 |                     | Check Valve Operation                          | S-110                 |
| Loose Hold-down Bolts                 |            |                       |                                      |                                    |                               |                              |  |                                |   |                            |                              |   | ●                   |   |                                 |                       |                      |                   |                     | Tighten Bolts                                  |                       |
| Faulty Reversing Valve                |            |                       |                                      |                                    | ●                             |                              |  |                                |   |                            |                              |   | ◆                   | ◆                                       | ◆                               |                       |                      | ◆                 | ◆                   | Replace Valve or Solenoid                      | S-21, 122             |
| Faulty Defrost Control                |            |                       |                                      |                                    | ●                             |                              |  |                                |   |                            |                              |   | ◆                   | ◆                                       | ◆                               |                       |                      | ◆                 | ◆                   | Test Control                                   | S-24                  |
| Faulty Defrost Thermostat             |            |                       |                                      |                                    |                               |                              |  |                                |   |                            |                              |   | ◆                   | ◆                                       | ◆                               |                       |                      | ◆                 | ◆                   | Test Defrost Thermostat                        | S-25                  |
| Flow rator Not Seating Properly       |            |                       |                                      |                                    |                               |                              |  | ●                              |   |                            |                              |   |                     |   |                                 |                       |                      | ●                 | ●                   | Check Flow rator & Seat or Replace Flow rator  | S-111                 |

● Cooling or Heating Cycle (Heat Pump)      ◆ Heating Cycle Only (Heat Pump)

# SERVICING

## TABLE OF CONTENTS

|       |   |     |        |  |     |
|-------|---|-----|--------|--|-----|
| S-1   | CHECKING VOLTAGE .....  | 70  | S-17D  | OPERATION TEST .....   | 128 |
| S-2   | CHECKING WIRING .....   | 70  | S-18   | TESTING CRANKCASE HEATER<br>(OPTIONAL ITEM) .....  | 129 |
| S-3   | CHECKING THERMOSTAT, WIRING<br>AND ANTICIPATOR .....                          | 70  | S-21   | CHECKING REVERSING VALVE<br>AND SOLENOID .....   | 129 |
| S-3A  | THERMOSTAT AND WIRING .....   | 70  | S-24   | TESTING DEFROST CONTROL .....  | 129 |
| S-3B  | COOLING ANTICIPATOR .....   | 71  | S-25   | TESTING DEFROST THERMOSTAT .....   | 130 |
| S-3C  | HEATING ANTICIPATOR .....   | 71  | S-26   | TESTING TEMPERATURE SENSORS<br>(COMFORTNET READY MODELS ONLY) .....  | 130 |
| S-3E  | CTK0*** COMFORTNET™ THERMOSTAT .....  | 71  | S-40   | MBR/AR*F ELECTRONIC BLOWER<br>TIME DELAY RELAY .....   | 130 |
| S-4   | CHECKING TRANSFORMER<br>AND CONTROL CIRCUIT .....                             | 73  | S-40A  | AVPTC/MBVC ELECTRONIC BLOWER/HEATER<br>CONTROL .....   | 131 |
| S-5   | CHECKING CYCLE PROTECTOR .....  | 77  | S-50   | CHECKING HEATER LIMIT CONTROL(S) .....   | 145 |
| S-6   | CHECKING TIME DELAY RELAY .....   | 77  | S-52   | CHECKING HEATER ELEMENTS .....   | 145 |
| S-7   | CHECKING CONTACTOR AND/OR RELAYS .....  | 77  | S-60   | ELECTRIC HEATER (OPTIONAL ITEM) .....  | 146 |
| S-8   | CHECKING CONTACTOR CONTACTS .....   | 77  | S-61A  | CHECKING HEATER LIMIT CONTROL(S) .....   | 146 |
| S-8A  | CHECKING UNITARY (UC) CONTROL<br>COMPRESSOR CONTACTOR/RELAY<br>CONTACTS ..... | 78  | S-61B  | CHECKING HEATER FUSE LINK .....  | 147 |
| S-9   | CHECKING FAN RELAY CONTACTS .....   | 78  |        | (OPTIONAL ELECTRIC HEATERS) .....  | 147 |
| S-10  | COPELAND COMFORT ALERT™ .....   | 79  | S-62   | CHECKING HEATER ELEMENTS .....   | 147 |
| S-10A | COPELAND COMFORT ALERT™ -<br>UNITARY (UC) CONTROL DIAGNOSTICS .....           | 84  | S-100  | REFRIGERATION REPAIR PRACTICE .....  | 147 |
| S-10B | COPELAND CORESENSE™ .....   | 98  | S-101  | LEAK TESTING<br>(NITROGEN OR NITROGEN-TRACED) .....  | 148 |
| S-11  | CHECKING LOSS OF CHARGE PROTECTOR ..  | 102 | S-102  | EVACUATION .....   | 148 |
| S-12  | CHECKING HIGH PRESSURE CONTROL .....  | 102 | S-103  | CHARGING .....   | 149 |
| S-13  | CHECKING LOW PRESSURE CONTROL .....   | 102 | S-104  | CHECKING COMPRESSOR EFFICIENCY .....   | 149 |
| S-15  | CHECKING CAPACITOR .....  | 102 | S-105A | PISTON CHART FOR .....   | 150 |
| S-15A | RESISTANCE CHECK .....  | 103 |        | ASX13, ANX13, ANZ13, GSX13, VSX13, SSX14,<br>ASX14, GSX14, ASZ13, GSZ13, GSZ14, VSZ13,<br>SSZ14, ASX16, GSX16, ASZ16 UNITS ..... | 150 |
| S-15B | CAPACITANCE CHECK .....   | 103 | S-105B | THERMOSTATIC EXPANSION VALVE .....   | 157 |
| S-16A | CHECKING FAN AND BLOWER MOTOR<br>WINDINGS (PSC MOTORS) .....                  | 104 | S-106  | OVERFEEDING .....  | 157 |
| S-16B | CHECKING FAN AND BLOWER MOTOR<br>(ECM MOTORS) .....                           | 104 | S-107  | UNDERFEEDING .....   | 157 |
| S-16C | CHECKING ECM MOTOR WINDINGS .....   | 107 | S-108  | SUPERHEAT .....  | 157 |
| S-16D | ECM CFM ADJUSTMENTS MBE / AEPF .....  | 107 | S-109  | CHECKING SUBCOOLING .....  | 160 |
| S-16E | BLOWER PERFORMANCE DATA .....   | 109 | S-109A | TWO SPEED APPLICATION .....  | 160 |
| S-16F | CHECKING HIGH EFFICIENCY MOTORS .....   | 109 | S-110  | CHECKING EXPANSION VALVE OPERATION ....  | 161 |
| S-16G | CHECKING EMERSON ULTRATECH™ ECM<br>MOTORS .....                               | 110 | S-111  | FIXED ORIFICE RESTRICTOR DEVICES .....   | 161 |
| S-16H | ECM CFM ADJUSTMENTS AVPTC/MBVC .....  | 112 | S-112  | CHECKING RESTRICTED LIQUID LINE .....  | 161 |
| S-17  | CHECKING COMPRESSOR .....   | 127 | S-113  | OVERCHARGE OF REFRIGERANT .....  | 161 |
| S-17A | RESISTANCE TEST .....   | 127 | S-202  | DUCT STATIC PRESSURES AND/OR STATIC<br>PRESSURE DROP ACROSS COILS .....  | 162 |
| S-17B | GROUND TEST .....   | 127 | S-203  | AIR HANDLER EXTERNAL STATIC .....  | 162 |
| S-17C | UNLOADER TEST PROCEDURE .....   | 128 | S-204  | COIL STATIC PRESSURE DROP .....  | 162 |



### WARNING

#### HIGH VOLTAGE!

Disconnect ALL power before servicing or installing. Multiple power sources may be present. Failure to do so may cause property damage, personal injury or death.



# SERVICING

## S-1 CHECKING VOLTAGE

1. Remove outer case, control panel cover, etc., from unit being tested.

With power ON:



**WARNING**  
Line Voltage now present.

2. Using a voltmeter, measure the voltage across terminals L1 and L2 of the contactor for the condensing unit or at the field connections for the air handler or heaters.

**ComfortNet™ Ready Condensing Units:** Measure the voltage across the L1 and L2 lugs on the unitary (UC) control.

3. No reading - indicates open wiring, open fuse(s) no power or etc., from unit to fused disconnect service. Repair as needed.
4. With ample voltage at line voltage connectors, energize the unit.
5. Measure the voltage with the unit starting and operating, and determine the unit Locked Rotor Voltage. **NOTE:** If checking heaters, be sure all heating elements are energized.

**Locked Rotor Voltage** is the actual voltage available at the compressor during starting, locked rotor, or a stalled condition. Measured voltage should be above minimum listed in chart below.

To measure Locked Rotor Voltage attach a voltmeter to the run "R" and common "C" terminals of the compressor, or to the T<sub>1</sub> and T<sub>2</sub> terminals of the contactor. Start the unit and allow the compressor to run for several seconds, then shut down the unit. Immediately attempt to restart the unit while measuring the Locked Rotor Voltage.

**ComfortNet Ready Condensing Units:** To measure the Locked Rotor Voltage, attach a voltmeter to the run "R" and common "C" terminals of the compressor or across the "R" and "C" lugs on the unitary (UC) control. Start the unit and allow the compressor to run for several seconds, then shut down the unit. Immediately attempt to restart the unit while measuring the Locked Rotor Voltage.

6. Locked rotor voltage should read within the voltage tabulation as shown. If the voltage falls below the minimum voltage, check the line wire size. Long runs of undersized wire can cause low voltage. If wire size is adequate, notify the local power company in regard to either low or high voltage.

| Unit Supply Voltage |      |     |
|---------------------|------|-----|
| Voltage             | Min. | Max |
| 208/230             | 197  | 253 |
| 460                 | 414  | 506 |

**NOTE:** When operating electric heaters on voltages other than 240 volts, refer to the System Operation section on electric heaters to calculate temperature rise and air flow. Low voltage may cause insufficient heating.

## S-2 CHECKING WIRING



**WARNING**  
**HIGH VOLTAGE!**  
Disconnect ALL power before servicing or installing. Multiple power sources may be present. Failure to do so may cause property damage, personal injury or death.



1. Check wiring visually for signs of overheating, damaged insulation and loose connections.
2. Use an ohmmeter to check continuity of any suspected open wires.
3. If any wires must be replaced, replace with comparable gauge and insulation thickness.

## S-3 CHECKING THERMOSTAT, WIRING, AND ANTICIPATOR

| THERMOSTAT WIRE SIZING CHART |                              |
|------------------------------|------------------------------|
| LENGTH OF RUN                | MIN. COPPER WIRE GAUGE (AWG) |
| 25 feet                      | 18                           |
| 50 feet                      | 16                           |
| 75 feet                      | 14                           |
| 100 feet                     | 14                           |
| 125 feet                     | 12                           |
| 150 feet                     | 12                           |

### ComfortNet Ready Models

1. Legacy Thermostat Wiring: The maximum wire length for 18 AWG thermostat wire is 100 feet.
2. Communicating Thermostat Wiring: The maximum wire length for 18 AWG thermostat wire is 100 feet.

## S-3A THERMOSTAT AND WIRING



**WARNING**  
Line Voltage now present.

With power ON, thermostat calling for cooling

1. Use a voltmeter to check for 24 volts at thermostat wires C and Y in the condensing unit control panel.
2. No voltage indicates trouble in the thermostat, wiring or external transformer source.
3. Check the continuity of the thermostat and wiring. Repair or replace as necessary.

# SERVICING

## Indoor Blower Motor

With power ON:



**WARNING**  
Line Voltage now present.

1. Set fan selector switch at thermostat to "ON" position.
2. With voltmeter, check for 24 volts at wires C and G.
3. No voltage indicates the trouble is in the thermostat or wiring.
4. Check the continuity of the thermostat and wiring. Repair or replace as necessary.

### Resistance Heaters

1. Set room thermostat to a higher setting than room temperature so both stages call for heat.
2. With voltmeter, check for 24 volts at each heater relay. Note: BBA/BBC heater relays are DC voltage.
3. No voltage indicates the trouble is in the thermostat or wiring.
4. Check the continuity of the thermostat and wiring. Repair or replace as necessary.

**NOTE:** Consideration must be given to how the heaters are wired (O.D.T. and etc.). Also safety devices must be checked for continuity.

### S-3B COOLING ANTICIPATOR

The cooling anticipator is a small heater (resistor) in the thermostat. During the "off" cycle, it heats the bimetal element helping the thermostat call for the next cooling cycle. This prevents the room temperature from rising too high before the system is restarted. A properly sized anticipator should maintain room temperature within 1 1/2 to 2 degree range.

The anticipator is supplied in the thermostat and is not to be replaced. If the anticipator should fail for any reason, the thermostat must be changed.

### S-3C HEATING ANTICIPATOR

The heating anticipator is a wire wound adjustable heater which is energized during the "ON" cycle to help prevent overheating of the conditioned space.

The anticipator is a part of the thermostat and if it should fail for any reason, the thermostat must be replaced. See the following tables for recommended heater anticipator setting in accordance to the number of electric heaters installed.

### S-3E CTK0\*\*\* COMFORTNET™ THERMOSTAT

#### OVERVIEW

The ComfortNet system (or CT system) is a system that includes a ComfortNet compatible modular blower and air conditioner or heat pump with a CTK0\* thermostat. Any other system configurations are considered invalid ComfortNet

systems and must be connected as a traditional (or legacy) system. The table below compares the valid CT systems.

|  |                                      |   |
|--|--------------------------------------|---|
| <i>CT compatible Air Handler or Modular Blower</i> | <i>CT compatible Air Conditioner</i> | <i>Full CT system benefits &amp; features</i> |
| <i>CT compatible Air Handler or Modular Blower</i> | <i>CT compatible Heat Pump</i>       | <i>Full CT system benefits &amp; features</i> |

A ComfortNet heating/air conditioning system differs from a legacy/traditional system in the manner in which the indoor unit, outdoor unit and thermostat interact with one another. In a traditional system, the thermostat sends commands to the indoor and outdoor units via analog 24 VAC signals. It is a one-way communication path in that the indoor and outdoor units typically do not return information to the thermostat.

On the other hand, the indoor unit, outdoor unit, and thermostat comprising a ComfortNet system "communicate" digitally with one another. It is now a two-way communications path. The thermostat still sends commands to the indoor and outdoor units. However, the thermostat may also request and receive information from both the indoor and outdoor units. This information may be displayed on the CT thermostat. The indoor and outdoor units also interact with one another. The outdoor unit may send commands to or request information from the indoor unit. This two-way digital communications between the thermostat and subsystems (indoor/outdoor unit) and between subsystems is the key to unlocking the benefits and features of the ComfortNet system.

Two-way digital communications is accomplished using only two wires. The thermostat and subsystem controls are powered with 24 VAC. Thus, a maximum of 4 wires between the equipment and thermostat is all that is required to operate the system.

### CTK0\* WIRING

**NOTE:** A removable plug connector is provided with the control to make thermostat wire connections. This plug may be removed, wire connections made to the plug, and replaced. It is **strongly** recommended that multiple wires into a single terminal be twisted together prior to inserting into the plug connector. Failure to do so may result in intermittent operation.

Typical 18 AWG thermostat wire may be used to wire the system components. However, communications reliability may be improved by using a high quality, shielded, twisted pair cable for the data transmission lines. In either case, 100 feet is the maximum length of wire between indoor unit and outdoor unit, or between indoor unit and thermostat.

### FOUR-WIRE INDOOR AND OUTDOOR WIRING

Typical wiring will consist of four wires between the indoor unit and outdoor unit and between the indoor unit and thermostat. The required wires are: (a) data lines, 1 and 2; (b) thermostat "R" (24 VAC hot) and "C" (24 VAC common).

# SERVICING

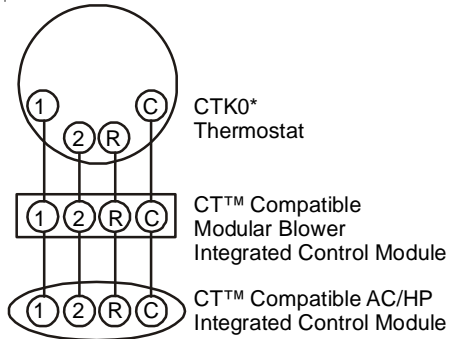

## System Wiring Using Four-Wires

### TWO-WIRE OUTDOOR, FOUR-WIRE INDOOR WIRING

Two wires only may be utilized between the indoor and outdoor units. For this wiring scheme, only the data lines, 1 and 2, are required between the indoor and outdoor units. A 40VA, 208/230 VAC to 24 VAC transformer must be installed in the outdoor unit to provide 24 VAC power to the outdoor unit's electronic control. The transformer is included with the CTK0\* kit. See kit instructions for mounting and wiring instructions. Four wires are required between the indoor unit and thermostat.

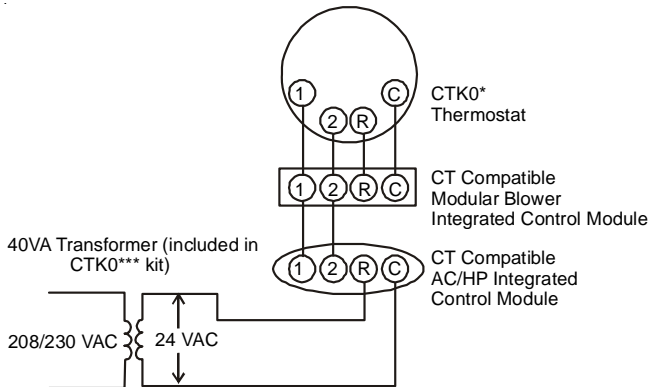

### System Wiring using Two-Wires between Furnace and AC/HP and Four-Wires between Furnace and Thermostat

### COMFORTNET™ SYSTEM ADVANCED FEATURES

The ComfortNet system permits access to additional system information, advanced setup features, and advanced diagnostic/troubleshooting features. These advanced features are organized into a menu structure. The menus are accessed and navigated as described as follows.

#### ACCESSING AND NAVIGATING THE ADVANCED FEATURES MENUS

The advanced system features are accessed using the ComfortNet™ thermostat. These advanced features are accessed as follows:

- On the CT thermostat Home Screen Display, touch the **Menu** key to display additional key choices.

- Touch and hold the **Installer Config** key for approximately 3 seconds to enter the Thermostat Options Configuration menu.
- Touch and hold the **Installer Config** key again for approximately 3 seconds to enter the Advanced Installer Configuration menu.

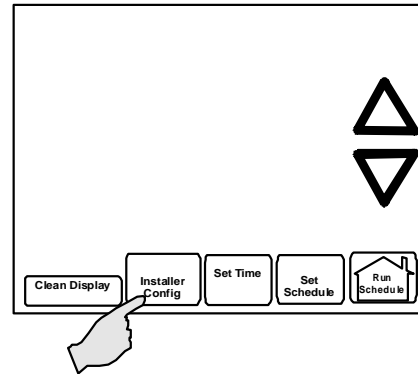

Upon entering the advanced menus, the Advanced Fault Menu is displayed. The display will change to the Fault Screen and indicate any faults that may be present in the indoor or outdoor equipment. If a fault is present, the Fault Screen will show the equipment and an error code with a description of the fault. Touch  $\triangleleft$  or  $\triangleright$  keys to view the fault status of any remaining equipment. The text **"NO FAULTS"** will be scrolled if no errors are present.

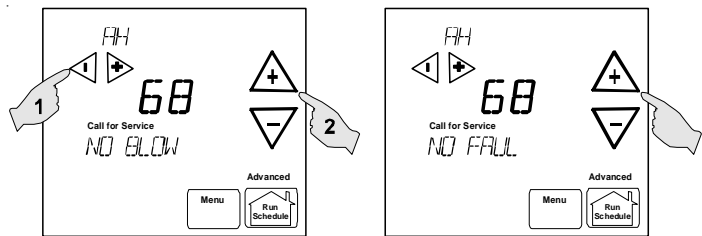

Touch the  $\triangle$  or  $\nabla$  to step through the list of installed equipment, including the thermostat. Touch the **Installer Config** key to enter the submenus for the equipment displayed. The text **"WORKING"** will be displayed in the scrolling display area while the data is being retrieved. The first sub-menu is then displayed. See tables below for listing of modular blower submenus.

Touch the  $\triangle$  or  $\nabla$  to step through the list of submenus and view settings. If a setting can be adjusted,  $\triangleleft$  and  $\triangleright$  keys will appear. Use the  $\triangleleft$  or  $\triangleright$  keys to adjust the setting to the desired value. Touch the  $\triangle$  or  $\nabla$  to step to the next item. **"WORKING"** will appear as the settings are being updated. **"DONE"** will appear to indicate the change was accepted. If the change is not accepted, the display will show **"FAIL"** then revert to the Fault Screen.



Some parameters being displayed switch between the item name and the item value. Touch the **Hold** key to momentarily stop the display from switching.



# SERVICING

To exit an equipment submenu and revert back to the equipment menus, touch the **Menu** key. Touch Menu again to revert back to the Thermostat Options Menu. Touch the **Run Schedule** key to step out of all menus and back to the CT thermostat Home Screen Display.

## S-4 CHECKING TRANSFORMER AND CONTROL CIRCUIT

**WARNING**  
**HIGH VOLTAGE!**  
Disconnect ALL power before servicing or installing. Multiple power sources may be present. Failure to do so may cause property damage, personal injury or death.

A step-down transformer (208/240 volt primary to 24 volt secondary) is provided with each indoor unit. This allows ample capacity for use with resistance heaters. The outdoor sections do not contain a transformer (see note below).

**NOTE:** ComfortNet™ ready condensing units may have an optional 240VAC to 24VAC transformer installed. This transformer provides 24VAC power to the unitary (UC) control in some communicating system installation scenarios.

**WARNING**  
Disconnect ALL power before servicing.

1. Remove control panel cover, or etc., to gain access to transformer.

With power ON:

**WARNING**  
Line Voltage now present.

2. Using a voltmeter, check voltage across secondary voltage side of transformer (R to C).
3. No voltage indicates faulty transformer, bad wiring, or bad splices.
4. Check transformer primary voltage at incoming line voltage connections and/or splices.
5. If line voltage available at primary voltage side of transformer and wiring and splices good, transformer is inoperative. Replace.

# SERVICING

## AVPTC AND MBVC ADVANCED USER MENUS

| CONFIGURATION                    |   |
|----------------------------------|---|
| Submenu Item                     | Indication (for Display Only; not User Modifiable)        |
| Electric Heat Size (HTR KW)      | Displays the size in kW of the selected electric heaters. |
| Motor HP (1/2, 3/4, or 1 MTR HP) | Displays the indoor blower motor horsepower.              |
| Heat ON Delay (HT ON)            | Displays the electric heat indoor blower ON delay.        |
| Heat OFF Delay (HT OFF)          | Displays the electric heat indoor blower OFF delay.       |

| DIAGNOSTICS                 |                                    |  |
|-----------------------------|------------------------------------|--|
| Submenu Item                | Indication/User Modifiable Options | Comments                                 |
| Fault 1 (FAULT #1)          | Most recent fault                  | For display only                         |
| Fault 2 (FAULT #2)          | Next most recent fault             | For display only                         |
| Fault 3 (FAULT #3)          | Next most recent fault             | For display only                         |
| Fault 4 (FAULT #4)          | Next most recent fault             | For display only                         |
| Fault 5 (FAULT #5)          | Next most recent fault             | For display only                         |
| Fault 6 (FAULT #6)          | Least recent fault                 | For display only                         |
| Clear Fault History (CLEAR) | NO or YES                          | Selecting "YES" clears the fault history |

**NOTE:** Consecutively repeated faults are shown a maximum of 3 times

| IDENTIFICATION          |  |
|-------------------------|--|
| Submenu Item            | Indication (for Display Only; not User Modifiable) |
| Model Number (MOD NUM)  | Displays the model number                          |
| Serial Number (SER NUM) | Displays the serial number (Optional)              |
| Software (SOFTWARE)     | Displays the application software revision         |

| SET-UP                     |  |  |
|----------------------------|--|--|
| Submenu Item               | User Modifiable Options                      | Comments   |
| Heat Airflow Trim (HT TRM) | -10% to +10% in 2% increments, default is 0% | Trims the electric heating airflow by the selected amount. |

| STATUS       |   |
|--------------|---|
| Submenu Item | Indication (for Display Only; not User Modifiable)  |
| Mode (MODE)  | Displays the current operating mode                 |
| CFM (CFM)    | Displays the airflow for the current operating mode |

# SERVICING

## ASXC/ASZC AND DSXC/DSZC ADVANCED USER MENUS

| CONFIGURATION                |   |
|------------------------------|---|
| Submenu Item                 | Indication (for Display Only; not User Modifiable)                |
| Number of AC Stages (CL STG) | Displays the number of air conditioning stages; applies to AC and |
| Number of HP Stages (HT STG) | Displays the number of heat pump stages; applies to HP only.      |
| AC Tonnage (TONS)            | Displays the air conditioning tonnage; applies to AC and HP.      |

| DIAGNOSTICS                 |                                    |  |
|-----------------------------|------------------------------------|--|
| Submenu Item                | Indication/User Modifiable Options | Comments                                 |
| Fault 1 (FAULT #1)          | Most recent AC/HP fault            | For display only                         |
| Fault 2 (FAULT #2)          | Next most recent AC/HP fault       | For display only                         |
| Fault 3 (FAULT #3)          | Next most recent AC/HP fault       | For display only                         |
| Fault 4 (FAULT #4)          | Next most recent AC/HP fault       | For display only                         |
| Fault 5 (FAULT #5)          | Next most recent AC/HP fault       | For display only                         |
| Fault 6 (FAULT #6)          | Least recent AC/HP fault           | For display only                         |
| Clear Fault History (CLEAR) | NO or YES                          | Selecting "YES" clears the fault history |

**NOTE:** Consecutively repeated faults are shown a maximum of 3 times

| IDENTIFICATION          |  |
|-------------------------|--|
| Submenu Item            | Indication (for Display Only; not User Modifiable)                 |
| Model Number (MOD NUM)  | Displays the air conditioner or heat pump model number             |
| Serial Number (SER NUM) | Displays the air conditioner or heat pump serial number (Optional) |
| Software (SOFTWARE)     | Displays the application software revision                         |

| SENSORS                             |                                       |   |
|-------------------------------------|---------------------------------------|---|
| Submenu Item                        | User Modifiable Options               | Comments  |
| Outdoor Air Temperature (AIR TMP)   | Displays the outdoor air temperature  | Sensor may or may not be available on an air conditioner. Check air conditioner instructions for details. |
| Outdoor Coil Temperature (COIL TMP) | Displays the outdoor coil temperature | Required for heat pump operation.   |

# SERVICING

## ASXC/ASZC AND DSXC/DSZC ADVANCED USER MENUS, CONT'D

| COOL SET-UP                     |   |  |
|---------------------------------|---|--|
| Submenu Item                    | User Modifiable Options                           | Comments   |
| Cool Airflow Trim (CL TRM)      | -10% to +10% in 2% increments, default is 0%      | Selects the airflow trim amount; applies to air conditioner only.  |
| Cool Airflow Profile (CL PRFL)  | A, B, C, or D, default is A                       | Selects the airflow profile; applies to air conditioner only.  |
| Cool ON Delay (CL ON)           | 5, 10, 20, or 30 seconds, default is 5 seconds    | Selects the indoor blower ON delay; applies to air conditioner only.   |
| Cool OFF Delay (CL OFF)         | 30, 60, 90, or 120 seconds, default is 30 seconds | Selects the indoor blower OFF delay; applies to air conditioner only.  |
| Dehumidification Select (DEHUM) | ON or OFF (default is OFF)                        | Selecting "OFF" disables dehumidification; selecting "ON" enables dehumidification; applies to air conditioner only. |

| STATUS       |   |
|--------------|---|
| Submenu Item | Indication (for Display Only; not User Modifiable)  |
| Mode (MODE)  | Displays the current air conditioner operating mode |
| CFM (CFM)    | Displays the airflow for the current operating mode |

| HEAT SET-UP                |  |   |
|----------------------------|--|---|
| Submenu Item               | User Modifiable Options                            | Comments  |
| Heat Airflow Trim (HT TRM) | -10% to +10% in 2% increments, default is 0%       | Selects the airflow trim amount; applies to heat pump only.                               |
| Heat ON Delay (HT ON)      | 5, 10, or 15 seconds, default is 5 seconds         | Selects the indoor blower heat ON delay; applies to heat pump only.                       |
| Heat OFF Delay (HT OFF)    | 30, 50, 70, or 90 seconds, default is 30 seconds   | Selects the indoor blower heat OFF delay; applies to heat pump only.                      |
| Defrost Interval (DEFROST) | 30, 60, 90, or 120 minutes, default is 30 minutes. | Selects the time interval between defrosts; applies to heat pump only.                    |
| Compressor Delay (CMP DLY) | 0, 5, 15, or 30 seconds, default is 5 seconds      | Selects the compressor off time after a reversing valve shift; applies to heat pump only. |

# SERVICING

## S-5 CHECKING CYCLE PROTECTOR

Some models feature a solid state, delay-on make after break time delay relay installed in the low voltage circuit. This control is used to prevent short cycling of the compressor under certain operating conditions.

The component is normally closed ( $R_1$  to  $Y_1$ ). A power interruption will break circuit ( $R_1$  to  $Y_1$ ) for approximately three minutes before resetting.

1. Remove wire from  $Y_1$  terminal.
2. Wait for approximately four (4) minutes if machine was running.

With power ON:



### WARNING

Line Voltage now present.

1. Apply 24 VAC to terminals  $R_1$  and  $R_2$ .
2. Should read 24 VAC at terminals  $Y_1$  and  $Y_2$ .
3. Remove 24 VAC at terminals  $R_1$  and  $R_2$ .
4. Should read 0 VAC at  $Y_1$  and  $Y_2$ .
5. Reapply 24 VAC to  $R_1$  and  $R_2$  - within approximately three (3) to four (4) minutes should read 24 VAC at  $Y_1$  and  $Y_2$ .

If not as above - replace relay.

## S-6 CHECKING TIME DELAY RELAY

Time delay relays are used in some of the blower cabinets to improve efficiency by delaying the blower off time. Time delays are also used in electric heaters to sequence in multiple electric heaters.



### WARNING

Disconnect ALL power before servicing.

1. Tag and disconnect all wires from male spade connections of relay.
2. Using an ohmmeter, measure the resistance across terminals H1 and H2. Should read approximately 150 ohms.
3. Using an ohmmeter, check for continuity across terminals 3 and 1, and 4 and 5.
4. Apply 24 volts to terminals H1 and H2. Check for continuity across other terminals - should test continuous. If not as above - replace.

**NOTE:** The time delay for the contacts to make will be approximately 20 to 50 seconds and to open after the coil is de-energized is approximately 40 to 90 seconds.

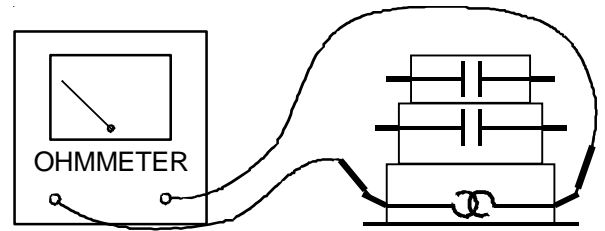

TESTING COIL CIRCUIT

## S-7 CHECKING CONTACTOR AND/OR RELAYS



### WARNING

HIGH VOLTAGE!

Disconnect ALL power before servicing or installing. Multiple power sources may be present. Failure to do so may cause property damage, personal injury or death.



The compressor contactor and other relay holding coils are wired into the low or line voltage circuits. When the control circuit is energized, the coil pulls in the normally open contacts or opens the normally closed contacts. When the coil is de-energized, springs return the contacts to their normal position.

**NOTE:** Most single phase contactors break only one side of the line (L1), leaving 115 volts to ground present at most internal components.

**NOTE:** The compressor contactor/relay in ComfortNet™ ready equipment is fully integrated into the unitary (UC) control. The compressor contactor/relay coil on the UC control is non-serviceable.

1. Remove the leads from the holding coil.
2. Using an ohmmeter, test across the coil terminals.

If the coil does not test continuous, replace the relay or contactor.

## S-8 CHECKING CONTACTOR CONTACTS



### WARNING

Disconnect ALL power before servicing.

#### SINGLE PHASE:

1. Disconnect the wire leads from the terminal (T) side of the contactor.
2. With power ON, energize the contactor.



### WARNING

Line Voltage now present.

# SERVICING

3. Using a voltmeter, test across terminals.

A. L2 - T1 - No voltage indicates CC1 contacts open.

If a no voltage reading is obtained - replace the contactor.

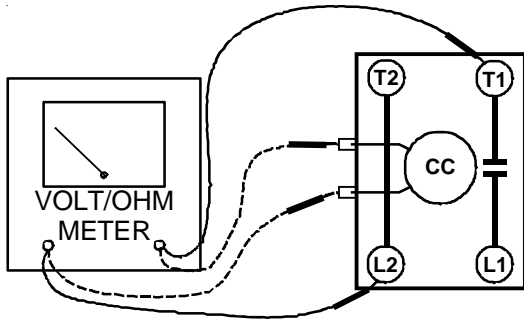

----- Ohmmeter for testing holding coil  
 — Voltmeter for testing contacts

## TESTING COMPRESSOR CONTACTOR (Single Phase)

### THREE PHASE

Using a voltmeter, test across terminals:

- A. L1-L2, L1-L3, and L2-L3 - If voltage is present, proceed to B. If voltage is not present, check breaker or fuses on main power supply..
- B. T1-T2, T1-T3, and T2-T3 - If voltage readings are not the same as in "A", replace contactor.

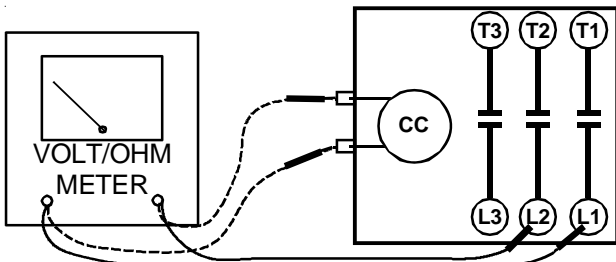

----- Ohmmeter for testing holding coil  
 — Voltmeter for testing contacts

## TESTING COMPRESSOR CONTACTOR (Three-phase)

### S-8A CHECKING UNITARY (UC) CONTROL COMPRESSOR CONTACTOR/RELAY CONTACTS

**⚠ WARNING**  
 Disconnect ALL power before servicing.

- 1. Connect voltmeter to lugs (L2) and (C).
- 2. With power ON, provide a call for cool or heat pump to energize the on-board compressor contactor/relay.

**⚠ WARNING**  
 Line Voltage now present.

3. Measure voltage across on-board compressor contactor/ relay contacts.

A. No voltage indicates the contacts are closed and the contactor/relay is functioning properly.

B. A reading of approximately half of the supply voltage (example: 115VAC for 230VAC) indicates the relay is open. Replace UC control if relay does not close.

NOTE: The unitary (UC) control has a built-in short cycle delay. Ensure short cycle delay has elapsed before making voltage measurements.

### S-9 CHECKING FAN RELAY CONTACTS

**⚠ WARNING**  
**HIGH VOLTAGE!**  
 Disconnect ALL power before servicing or installing. Multiple power sources may be present. Failure to do so may cause property damage, personal injury or death.



- 1. Disconnect wire leads from terminals 2 and 4 of Fan Relay Cooling and 2 and 4, 5 and 6 of Fan Relay Heating.
- 2. Using an ohmmeter, test between 2 and 4 - should read open. Test between 5 and 6 - should read continuous.
- 3. With power ON, energize the relays.

**⚠ WARNING**  
 Line Voltage now present.

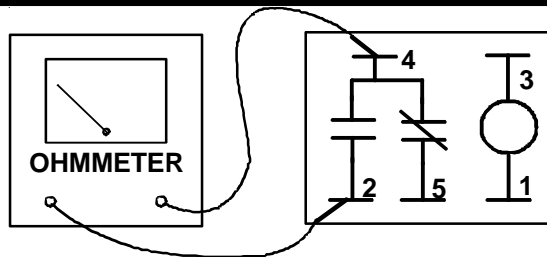

### TESTING FAN RELAY

- 4. Using an ohmmeter, test between 2 and 4 - should read continuous . Test between 5 and 6 - should read open.
- 5. If not as above, replace the relay.

**FAN RELAY CONTACTS - UNITARY (UC) CONTROL**  
*Applies to ASXC/ASZC and DSXC/DSZC Models*

# SERVICING

Condenser fan control for the ASXC/ASZC and DSXC/DSZC models is fully integrated into the UC control. The control supports one- or two-speed PSC condenser fan motors and one- or two-speed ECM condenser fan motors.

The fan motor is controlled by two on-board relays. Connection to the fan motor is via a 6-circuit plug connector. Wiring to the connector is dependant upon the type of condenser fan motor used. See unit wiring diagram for details.

## CHECKING RELAY CONTACTS - PSC FAN MOTOR

 **WARNING**  
**HIGH VOLTAGE!**  
Disconnect ALL power before servicing or installing. Multiple power sources may be present. Failure to do so may cause property damage, personal injury or death.



1. Disconnect the motor leads from 6-circuit fan motor wire harness.
2. Connect a voltmeter between circuit 3 and circuits 2 (low speed) or 1 (high speed).

**NOTE:** Circuit 3 is connected directly to L2.

3. Energize the system at low or high stage.

 **WARNING**  
Line Voltage now present.

4. The measured voltage between circuit 3 and circuits 2 or 1 should be approximately 0VAC, which indicates the relay contacts are closed. A voltage measurement of approximately 115VAC indicates the relay is open. Replace the control if the relay checks open when it should be closed. See notes and cautions below.

**NOTE:** Ensure any ON delays have expired before making voltage measurements

**CAUTION:** Prolonged operation with the condenser fan motor disconnected will cause the high pressure switch to trip.

## CHECKING RELAY CONTACTS - ECM FAN MOTOR

 **WARNING**  
**HIGH VOLTAGE!**  
Disconnect ALL power before servicing or installing. Multiple power sources may be present. Failure to do so may cause property damage, personal injury or death.



1. Disconnect the motor leads from 6-circuit fan motor wire harness.

2. Connect a voltmeter between circuit 6 and circuits 3 (low speed) or 1 (high speed).

**NOTE:** Circuit 6 is connected directly to 24VAC.

3. Energize the system at low or high stage.

 **WARNING**  
Line Voltage now present.

4. The measured voltage between circuit 6 and circuits 3 or 1 should be approximately 0VAC, which indicates the relay contacts are closed. A voltage measurement of approximately 24VAC indicates the relay is open. Replace the control if the relay checks open when it should be closed. See notes and cautions below.

5. Circuit 5 is connected to 24VAC common. The measured voltage between circuits 6 and 5 should be 24VAC.

**NOTE:** Ensure any ON delays have expired before making voltage measurements

**CAUTION:** Prolonged operation with the condenser fan motor disconnected will cause the high pressure switch to trip.

## S-10 COPELAND COMFORT ALERT™

### DIAGNOSTICS - 3-WIRE MODULE

*Applies to ASX /ASZ and DSX/DSZ units*

 **WARNING**  
**HIGH VOLTAGE**  
Disconnect ALL power before servicing or installing this unit. Multiple power sources may be present. Failure to do so may cause property damage, personal injury or death.



Comfort Alert™ is self-contained with no required external sensors and is designed to install directly into the electrical box of any residential condensing unit that has a Copeland Scroll™ compressor inside.

Once attached, Comfort Alert provides around-the-clock monitoring for common electrical problems, compressor defects and broad system faults. If a glitch is detected, an LED indicator flashes the proper alert codes to help you quickly pinpoint the problem. *See Diagnostic Table: 3-Wire Comfort Alert Module on previous page.)*

# SERVICING

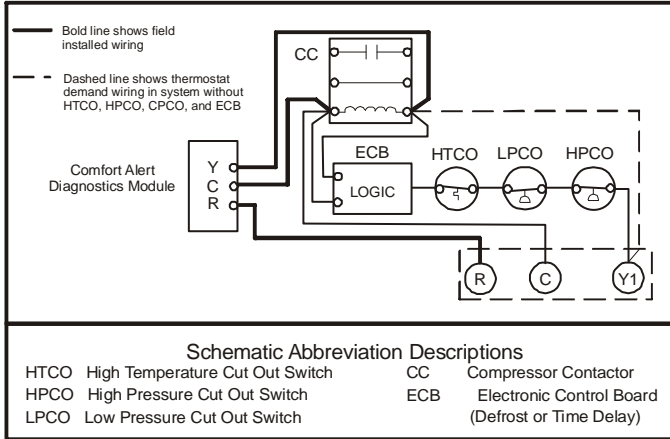

## Wiring Schematic - 3-Wire Comfort Alert Module

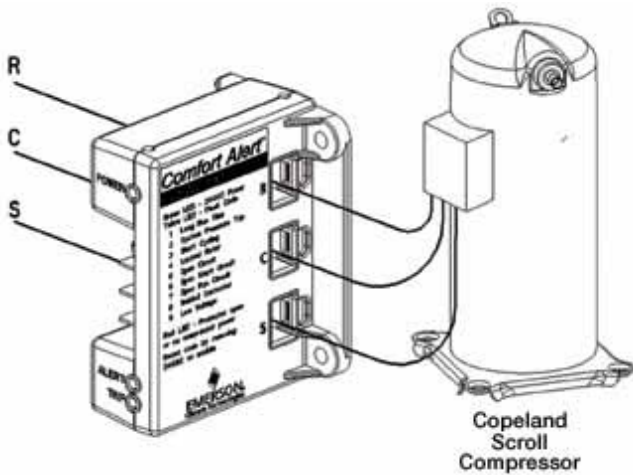



# SERVICING

## DIAGNOSTICS TABLE: 3-WIRE COMFORT ALERT™ MODULE

| Status LED                             | Status LED Description  | Status LED Troubleshooting Information   |
|--|---|--|
| <b>Green “POWER”</b>                   | <b>Module has power</b>   | Supply voltage is present at module terminals  |
| <b>Red “TRIP”</b>                      | Thermostat demand signal Y1 is present, but the compressor is not running                           | <ol style="list-style-type: none"> <li>1. Compressor protector is open</li> <li>2. Outdoor unit power disconnect is open</li> <li>3. Compressor circuit breaker or fuse(s) is open</li> <li>4. Broken wire or connector is not making contact</li> <li>5. Low pressure switch open if present in system</li> <li>6. Compressor contactor has failed open</li> </ol>  |
| <b>Yellow “ALERT”<br/>Flash Code 1</b> | <b>Long Run Time</b><br>Compressor is running extremely long run cycles                             | <ol style="list-style-type: none"> <li>1. Low refrigerant charge</li> <li>2. Evaporator blower is not running</li> <li>3. Evaporator coil is frozen</li> <li>4. Faulty metering device</li> <li>5. Condenser coil is dirty</li> <li>6. Liquid line restriction (filter drier blocked if present in system)</li> <li>7. Thermostat is malfunctioning</li> </ol>   |
| <b>Yellow “ALERT”<br/>Flash Code 2</b> | <b>System Pressure Trip</b><br>Discharge or suction pressure out of limits or compressor overloaded | <ol style="list-style-type: none"> <li>1. High head pressure</li> <li>2. Condenser coil poor air circulation (dirty, blocked, damaged)</li> <li>3. Condenser fan is not running</li> <li>4. Return air duct has substantial leakage</li> <li>5. If low pressure switch present in system, check Flash Code 1 information</li> </ol>  |
| <b>Yellow “ALERT”<br/>Flash Code 3</b> | <b>Short Cycling</b><br>Compressor is running only briefly  | <ol style="list-style-type: none"> <li>1. Thermostat demand signal is intermittent</li> <li>2. Time delay relay or control board defective</li> <li>3. If high pressure switch present go to Flash Code 2 information</li> <li>4. If low pressure switch present go to Flash Code 1 information</li> </ol>   |
| <b>Yellow “ALERT”<br/>Flash Code 4</b> | <b>Locked Rotor</b>   | <ol style="list-style-type: none"> <li>1. Run capacitor has failed</li> <li>2. Low line voltage (contact utility if voltage at disconnect is low)</li> <li>3. Excessive liquid refrigerant in compressor</li> <li>4. Compressor bearings are seized</li> </ol>   |
| <b>Yellow “ALERT”<br/>Flash Code 5</b> | <b>Open Circuit</b>   | <ol style="list-style-type: none"> <li>1. Outdoor unit power disconnect is open</li> <li>2. Compressor circuit breaker or fuse(s) is open</li> <li>3. Compressor contactor has failed open</li> <li>4. High pressure switch is open and requires manual reset</li> <li>5. Open circuit in compressor supply wiring or connections</li> <li>6. Unusually long compressor protector reset time due to extreme ambient temperature</li> <li>7. Compressor windings are damaged</li> </ol> |
| <b>Yellow “ALERT”<br/>Flash Code 6</b> | <b>Open Start Circuit</b><br>Current only in run circuit  | <ol style="list-style-type: none"> <li>1. Run capacitor has failed</li> <li>2. Open circuit in compressor start wiring or connections</li> <li>3. Compressor start winding is damaged</li> </ol>   |
| <b>Yellow “ALERT”<br/>Flash Code 7</b> | <b>Open Run Circuit</b><br>Current only in start circuit  | <ol style="list-style-type: none"> <li>1. Open circuit in compressor run wiring or connections</li> <li>2. Compressor run winding is damaged</li> </ol>  |
| <b>Yellow “ALERT”<br/>Flash Code 8</b> | <b>Welded Contactor</b><br>Compressor always runs   | <ol style="list-style-type: none"> <li>1. Compressor contactor has failed closed</li> <li>2. Thermostat demand signal not connected to module</li> </ol>   |
| <b>Yellow “ALERT”<br/>Flash Code 9</b> | <b>Low Voltage</b><br>Control circuit < 17VAC   | <ol style="list-style-type: none"> <li>1. Control circuit transformer is overloaded</li> <li>2. Low line voltage (contact utility if voltage at disconnect is low)</li> </ol>  |

- Flash Code number corresponds to a number of LED flashes, followed by a pause and then repeated
- TRIP and ALERT LEDs flashing at same time means control circuit voltage is too low for operation.
- Reset ALERT Flash code by removing 24VAC power from module
- Last ALERT Flash code is displayed for 1 minute after module is powered on.

# SERVICING

## DIAGNOSTICS - 2-WIRE MODULE

Applies to ASX130[18-60]CA, ASX140[18-36]1CA, ASX140421DA, and ASX140[48-60]1BA units

**WARNING**

**HIGH VOLTAGE**  
Disconnect ALL power before servicing or installing this unit. Multiple power sources may be present. Failure to do so may cause property damage, personal injury or death.



Comfort Alert™ is self-contained with no required external sensors and is designed to install directly into the electrical box of any residential condensing unit that has a Copeland Scroll™ compressor inside.

Once attached, Comfort Alert™ provides around-the-clock monitoring for common electrical problems, compressor defects and broad system faults. If a glitch is detected, an LED indicator flashes the proper alert codes to help you quickly pinpoint the problem. (See *Diagnostic Table: 2-Wire Comfort Alert™ Module* on previous page.)

**NOTE:** The 2-wire Comfort Alert™ module does not provide a diagnostic code 8, Welded Contactor. Additionally, the 2-wire module does not require a manual reset to clear alert codes.

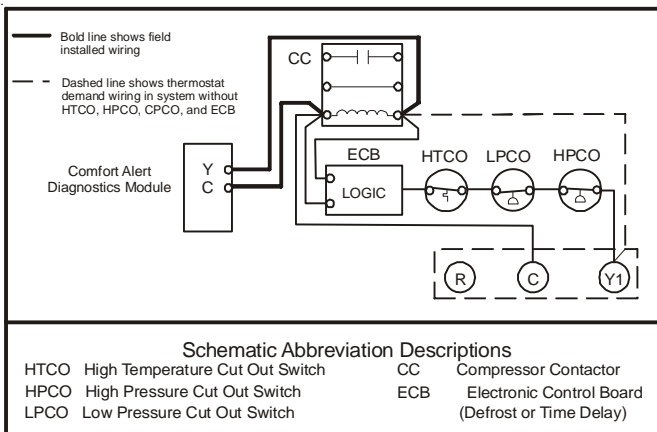
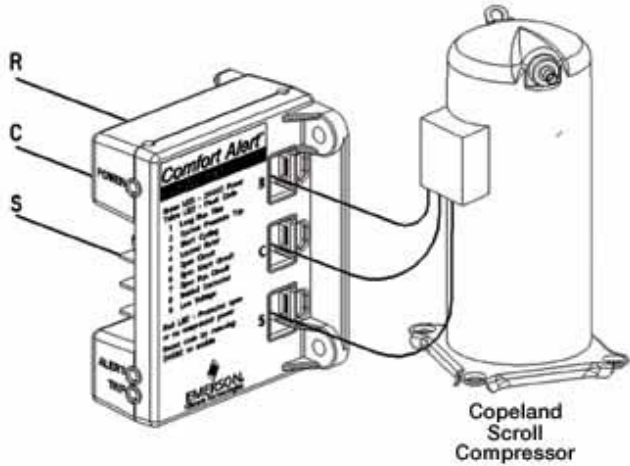

### Wiring Schematic - 2-Wire Comfort Alert™ Module



# SERVICING

## DIAGNOSTICS TABLE: 2-WIRE COMFORT ALERT™ MODULE

| Status LED                             | Status LED Description  | Status LED Troubleshooting Information   |
|--|---|--|
| <b>Green “POWER”</b>                   | <b>Module has power</b>   | Supply voltage is present at module terminals  |
| <b>Red “TRIP”</b>                      | Thermostat demand signal Y1 is present, but the compressor is not running                           | <ol style="list-style-type: none"> <li>1. Compressor protector is open</li> <li>2. Outdoor unit power disconnect is open</li> <li>3. Compressor circuit breaker or fuse(s) is open</li> <li>4. Broken wire or connector is not making contact</li> <li>5. Low pressure switch open if present in system</li> <li>6. Compressor contactor has failed open</li> </ol>  |
| <b>Yellow “ALERT”<br/>Flash Code 1</b> | <b>Long Run Time</b><br>Compressor is running extremely long run cycles                             | <ol style="list-style-type: none"> <li>1. Low refrigerant charge</li> <li>2. Evaporator blower is not running</li> <li>3. Evaporator coil is frozen</li> <li>4. Faulty metering device</li> <li>5. Condenser coil is dirty</li> <li>6. Liquid line restriction (filter drier blocked if present in system)</li> <li>7. Thermostat is malfunctioning</li> </ol>   |
| <b>Yellow “ALERT”<br/>Flash Code 2</b> | <b>System Pressure Trip</b><br>Discharge or suction pressure out of limits or compressor overloaded | <ol style="list-style-type: none"> <li>1. High head pressure</li> <li>2. Condenser coil poor air circulation (dirty, blocked, damaged)</li> <li>3. Condenser fan is not running</li> <li>4. Return air duct has substantial leakage</li> <li>5. If low pressure switch present in system, check Flash Code 1 information</li> </ol>  |
| <b>Yellow “ALERT”<br/>Flash Code 3</b> | <b>Short Cycling</b><br>Compressor is running only briefly  | <ol style="list-style-type: none"> <li>1. Thermostat demand signal is intermittent</li> <li>2. Time delay relay or control board defective</li> <li>3. If high pressure switch present go to Flash Code 2 information</li> <li>4. If low pressure switch present go to Flash Code 1 information</li> </ol>   |
| <b>Yellow “ALERT”<br/>Flash Code 4</b> | <b>Locked Rotor</b>   | <ol style="list-style-type: none"> <li>1. Run capacitor has failed</li> <li>2. Low line voltage (contact utility if voltage at disconnect is low)</li> <li>3. Excessive liquid refrigerant in compressor</li> <li>4. Compressor bearings are seized</li> </ol>   |
| <b>Yellow “ALERT”<br/>Flash Code 5</b> | <b>Open Circuit</b>   | <ol style="list-style-type: none"> <li>1. Outdoor unit power disconnect is open</li> <li>2. Compressor circuit breaker or fuse(s) is open</li> <li>3. Compressor contactor has failed open</li> <li>4. High pressure switch is open and requires manual reset</li> <li>5. Open circuit in compressor supply wiring or connections</li> <li>6. Unusually long compressor protector reset time due to extreme ambient temperature</li> <li>7. Compressor windings are damaged</li> </ol> |
| <b>Yellow “ALERT”<br/>Flash Code 6</b> | <b>Open Start Circuit</b><br>Current only in run circuit  | <ol style="list-style-type: none"> <li>1. Run capacitor has failed</li> <li>2. Open circuit in compressor start wiring or connections</li> <li>3. Compressor start winding is damaged</li> </ol>   |
| <b>Yellow “ALERT”<br/>Flash Code 7</b> | <b>Open Run Circuit</b><br>Current only in start circuit  | <ol style="list-style-type: none"> <li>1. Open circuit in compressor run wiring or connections</li> <li>2. Compressor run winding is damaged</li> </ol>  |
| <b>Yellow “ALERT”<br/>Flash Code 9</b> | <b>Low Voltage</b><br>Control circuit < 17VAC   | <ol style="list-style-type: none"> <li>1. Control circuit transformer is overloaded</li> <li>2. Low line voltage (contact utility if voltage at disconnect is low)</li> </ol>  |

- Flash Code number corresponds to a number of LED flashes, followed by a pause and then repeated
- TRIP and ALERT LEDs flashing at same time means control circuit voltage is too low for operation.
- Last ALERT Flash code is displayed for 1 minute after module is powered on.



# SERVICING

## S-10A COPELAND COMFORT ALERT™ -

### UNITARY (UC) CONTROL DIAGNOSTICS

*Applies to ASXC, ASZC, DSXC, and DSZC models*

The diagnostic tables on following pages provide detailed information regarding the system symptoms, indicators (LED and thermostat), potential problem(s), and corrective actions. The diagnostic information applies to systems wired as 24VAC traditional (legacy) systems and systems wired as communicating systems with the CTK0\* communicating thermostat.

**WARNING**  
**HIGH VOLTAGE!**  
Disconnect ALL power before servicing or installing. Multiple power sources may be present. Failure to do so may cause property damage, personal injury or death.  

The Copeland Comfort Alert™ diagnostics are fully integrated into the unitary (UC) control. The UC control and integrated Comfort Alert™ diagnostics provide around-the-clock monitoring for common electrical problems, compressor defects and broad system faults. If a problem is detected, LED indicators flash the proper alert codes to help you quickly pinpoint the problem.

# SERVICING

| Symptoms of Abnormal Operation<br>(Legacy & ComfortNet™ Thermostat)   | Diagnostic/Status LED Codes |         |     |                                       | Fault Description   | ComfortNet™<br>Thermostat Only |      | Possible Causes  | Corrective Actions  | Notes & Cautions  |
|---|-----------------------------|---------|-----|---------------------------------------|---|--------------------------------|------|--|---|---|
|   | Green                       | Yellow  | Red | Red/Y1                                |   | Message                        | Code |  |   |   |
| <ul style="list-style-type: none"> <li>Very long run time.</li> <li>Four consecutive compressor or protector trips with average run time between trips greater than 3 hours.</li> <li>Compressor or operating at high speed and outdoor fan operating at low speed</li> <li>Integrated control module diagnostic/status LED's display the indicated code.</li> </ul>  | OFF                         | 1 Flash | OFF | ON if call present;<br>OFF if no call | <ul style="list-style-type: none"> <li>Low Side Fault.</li> </ul>         | LOW SIDE<br>FAULT              | 01   | <ul style="list-style-type: none"> <li>Low refrigerant charge.</li> <li>Restriction in liquid line.</li> <li>Indoor blower motor failure.</li> <li>Indoor thermostat set extremely low.</li> </ul> | <ul style="list-style-type: none"> <li>Verify refrigerant charge; adjust as needed.</li> <li>Check for restricted liquid line; repair/replace as needed.</li> <li>Check indoor blower motor; repair/replace as needed.</li> <li>Check indoor thermostat setting.</li> </ul>   | <ul style="list-style-type: none"> <li>Turn power OFF prior to repair.</li> <li>Fault will clear after 30 consecutive normal cycles.</li> <li>Fault may be cleared by cycling 24VAC to control.</li> <li>Replace with correct replacement part(s).</li> </ul> |
| <ul style="list-style-type: none"> <li>Compressor and outdoor fan are off.</li> <li>Thermostat demand is present.</li> <li>Integrated control module diagnostic/status LED's display the indicated code.</li> </ul>   | ON                          | 1 Flash | OFF | ON if call present;<br>OFF if no call | <ul style="list-style-type: none"> <li>Low Pressure CO Trip.</li> </ul>   | LPS OPEN                       | 01   | <ul style="list-style-type: none"> <li>Low refrigerant charge.</li> <li>Restriction in liquid line.</li> <li>Indoor blower motor failure.</li> <li>Indoor thermostat set extremely low.</li> </ul> | <ul style="list-style-type: none"> <li>Verify refrigerant charge; adjust as needed.</li> <li>Check for restricted liquid line; repair/replace as needed.</li> <li>Check indoor blower motor; repair/replace as needed.</li> <li>Check low pressure switch; repair/replace as needed.</li> <li>Check indoor thermostat setting.</li> </ul> | <ul style="list-style-type: none"> <li>Turn power OFF prior to repair.</li> <li>Replace with correct replacement part(s).</li> </ul>  |
| <ul style="list-style-type: none"> <li>Compressor and outdoor fan are off.</li> <li>Low pressure switch trip 3 times within same thermostat demand.</li> <li>Thermostat demand is present.</li> <li>Integrated control module diagnostic/status LED's display the indicated code.</li> <li>ComfortNet™ thermostat "Call for Service" icon illuminated.</li> <li>ComfortNet™ thermostat scrolls "Check Air Conditioner" or "Check Heat Pump" message.</li> </ul> | ON                          | 1 Flash | ON  | ON if call present;<br>OFF if no call | <ul style="list-style-type: none"> <li>LPCO Lockout (3 Trips).</li> </ul> | LPS<br>LOCKOUT                 | 01   | <ul style="list-style-type: none"> <li>Low refrigerant charge.</li> <li>Restriction in liquid line.</li> <li>Indoor blower motor failure.</li> <li>Indoor thermostat set extremely low.</li> </ul> | <ul style="list-style-type: none"> <li>Verify refrigerant charge; adjust as needed.</li> <li>Check for restricted liquid line; repair/replace as needed.</li> <li>Check indoor blower motor; repair/replace as needed.</li> <li>Check low pressure switch; repair/replace as needed.</li> <li>Check indoor thermostat setting.</li> </ul> | <ul style="list-style-type: none"> <li>Turn power OFF prior to repair.</li> <li>Must clear fault by cycling 24VAC to control.</li> <li>Replace with correct replacement part(s).</li> </ul>   |

# SERVICING

| Symptoms of Abnormal Operation<br>(Legacy & ComfortNet™ Thermostat)   | Diagnostic/Status LED Codes |              |     | Fault Description  | ComfortNet™ Thermostat Only |      | Possible Causes   | Corrective Actions  | Notes & Cautions   |
|---|-----------------------------|--------------|-----|--|-----------------------------|------|---|---|--|
|   | Green                       | Yellow       | Red |  | Message                     | Code |   |   |  |
| <ul style="list-style-type: none"> <li>Four consecutive compressor protector trips with average run time between trips greater than 1 minute and less than 15 minutes.</li> <li>Low pressure and high pressure switches are closed.</li> <li>Integrated control module diagnostic/status LED's display the indicated code.</li> </ul>   | OFF                         | 2<br>Flashes | OFF | <ul style="list-style-type: none"> <li>High Side Fault</li> </ul>        | <i>HIGH SIDE FAULT</i>      | 02   | <ul style="list-style-type: none"> <li>Blocked condenser coil.</li> <li>Outdoor fan not running.</li> </ul>         | <ul style="list-style-type: none"> <li>Check and clean condenser coil.</li> <li>Check outdoor fan motor; repair/replace as needed.</li> <li>Check outdoor fan motor wiring; repair/replace as needed.</li> <li>Check outdoor fan motor capacitor; replace as needed.</li> </ul> | <ul style="list-style-type: none"> <li>Turn power OFF prior to repair.</li> <li>Fault will clear after 4 consecutive normal cycles.</li> <li>Fault may be cleared by cycling 24VAC to control.</li> <li>Replace with correct replacement part(s).</li> </ul> |
| <ul style="list-style-type: none"> <li>Compressor and outdoor fan are off.</li> <li>Thermostat demand is present.</li> <li>Integrated control module diagnostic/status LED's display the indicated code.</li> </ul>   | ON                          | 2<br>Flashes | OFF | <ul style="list-style-type: none"> <li>High Pressure CO Trip</li> </ul>  | <i>HPS OPEN</i>             | 02   | <ul style="list-style-type: none"> <li>Blocked condenser coil.</li> <li>Outdoor fan not running.</li> </ul>         | <ul style="list-style-type: none"> <li>Check and clean condenser coil.</li> <li>Check outdoor fan motor; repair/replace as needed.</li> <li>Check outdoor fan motor wiring; repair/replace as needed.</li> <li>Check outdoor fan motor capacitor; replace as needed.</li> </ul> | <ul style="list-style-type: none"> <li>Turn power OFF prior to repair.</li> <li>Replace with correct replacement part(s).</li> </ul>   |
| <ul style="list-style-type: none"> <li>Compressor and outdoor fan are off.</li> <li>Low pressure switch trip 3 times within same thermostat demand.</li> <li>Thermostat demand is present.</li> <li>Integrated control module diagnostic/status LED's display the indicated code.</li> <li>ComfortNet™ thermostat "Call for Service" icon illuminated.</li> <li>ComfortNet™ thermostat scrolls "Check Air Conditioner" or "Check Heat Pump" message.</li> </ul> | ON                          | 2<br>Flashes | ON  | <ul style="list-style-type: none"> <li>HFCO Lockout (3 Trips)</li> </ul> | <i>HPS LOCKOUT</i>          | 02   | <ul style="list-style-type: none"> <li>Blocked condenser coil.</li> <li>Outdoor fan not running.</li> </ul>         | <ul style="list-style-type: none"> <li>Check and clean condenser coil.</li> <li>Check outdoor fan motor; repair/replace as needed.</li> <li>Check outdoor fan motor wiring; repair/replace as needed.</li> <li>Check outdoor fan motor capacitor; replace as needed.</li> </ul> | <ul style="list-style-type: none"> <li>Turn power OFF prior to repair.</li> <li>Must clear fault by cycling 24VAC to control.</li> <li>Replace with correct replacement part(s).</li> </ul>  |
| <ul style="list-style-type: none"> <li>Run time for last 4 cycles is less than 3 minutes each.</li> <li>Compressor protector has not tripped.</li> <li>Low pressure and high pressure switches are closed.</li> <li>Integrated control module diagnostic/status LED's display the indicated code.</li> </ul>  | OFF                         | 3<br>Flashes | OFF | <ul style="list-style-type: none"> <li>Short Cycling</li> </ul>          | <i>CM PRS HRT CYCLE</i>     | 03   | <ul style="list-style-type: none"> <li>Intermittent thermostat demand.</li> <li>Faulty compressor relay.</li> </ul> | <ul style="list-style-type: none"> <li>Check thermostat and thermostat wiring; repair/replace as needed.</li> <li>Check compressor or relay operation; replace control as needed.</li> </ul>  | <ul style="list-style-type: none"> <li>Turn power OFF prior to repair.</li> <li>Fault will clear after 4 consecutive normal cycles.</li> <li>Fault may be cleared by cycling 24VAC to control.</li> <li>Replace with correct replacement part(s).</li> </ul> |

# SERVICING

| Symptoms of Abnormal Operation<br>(Legacy & ComfortNet™ Thermostat)  | Diagnostic/Status LED Codes |              |     |                                       | Fault Description  | ComfortNet™ Thermostat Only |      | Possible Causes   | Corrective Actions   | Notes & Cautions  |
|--|-----------------------------|--------------|-----|---------------------------------------|--|-----------------------------|------|---|--|---|
|  | Green                       | Yellow       | Red | Red Y1                                |  | Message                     | Code |   |  |   |
|  | OFF                         | 4<br>Flashes | ON  | ON if call present;<br>OFF if no call |  | Locked Rotor                | 04   |   |  |   |
| <ul style="list-style-type: none"> <li>Compressor and outdoor fan are off.</li> <li>Compressor protector trips four consecutive times.</li> <li>Average run time between trips is less than 15 seconds.</li> <li>Integrated control module diagnostic/status LED's display the indicated code.</li> <li>ComfortNet™ thermostat "Call for Service" icon illuminated.</li> <li>ComfortNet™ thermostat scrolls "Check Air Conditioner" or "Check Heat Pump" message.</li> </ul>                                   | OFF                         | 4<br>Flashes | ON  | ON if call present;<br>OFF if no call | <ul style="list-style-type: none"> <li>Locked Rotor</li> </ul>               | LOCKED<br>ROTOR             | 04   | <ul style="list-style-type: none"> <li>Compressor bearings are seized.</li> <li>Failed compressor run capacitor.</li> <li>Faulty run capacitor wiring.</li> <li>Low line voltage.</li> </ul>  | <ul style="list-style-type: none"> <li>Check compressor operation; repair/replace as needed.</li> <li>Check run capacitor; replace as needed.</li> <li>Check wiring; repair/replace as needed.</li> <li>Verify line voltage is within range on rating plate; contact local utility is out of range.</li> </ul> | <ul style="list-style-type: none"> <li>Turn power OFF prior to repair.</li> <li>Must clear fault by cycling 24VAC to control.</li> <li>Replace with correct replacement part(s).</li> </ul>   |
| <ul style="list-style-type: none"> <li>Compressor and outdoor fan are off for greater than 4 hours.</li> <li>Low pressure and high pressure switches are closed.</li> <li>Integrated control module diagnostic/status LED's display the indicated code.</li> <li>ComfortNet™ thermostat "Call for Service" icon illuminated.</li> <li>ComfortNet™ thermostat scrolls "Check Air Conditioner" or "Check Heat Pump" message.</li> </ul>  | OFF                         | 5<br>Flashes | OFF | ON if call present;<br>OFF if no call | <ul style="list-style-type: none"> <li>Open Circuit</li> </ul>               | OPEN<br>CIRCUIT             | 05   | <ul style="list-style-type: none"> <li>Power is disconnected.</li> <li>Failed compressor protector.</li> <li>Compressor not properly wired to control.</li> </ul>   | <ul style="list-style-type: none"> <li>Check circuit breakers and fuses.</li> <li>Check wiring to unit; repair/replace as needed.</li> <li>Check compressor; repair/replace as needed.</li> <li>Check compressor wiring; repair/replace as needed.</li> </ul>  | <ul style="list-style-type: none"> <li>Turn power OFF prior to repair.</li> <li>Fault will clear after 1 normal cycle.</li> <li>Fault may be cleared by cycling 24VAC to control.</li> <li>Replace with correct replacement part(s).</li> </ul> |
| <ul style="list-style-type: none"> <li>Compressor and outdoor fan are off.</li> <li>Low pressure and high pressure switches are closed.</li> <li>Integrated control module diagnostic/status LED's display the indicated code.</li> <li>ComfortNet™ thermostat "Call for Service" icon illuminated.</li> <li>ComfortNet™ thermostat scrolls "Check Air Conditioner" or "Check Heat Pump" message.</li> </ul>   | OFF                         | 6<br>Flashes | OFF | ON if call present;<br>OFF if no call | <ul style="list-style-type: none"> <li>Open Start Circuit</li> </ul>         | OPEN START                  | 06   | <ul style="list-style-type: none"> <li>Compressor start winding is open.</li> <li>Failed compressor run capacitor.</li> <li>Faulty run capacitor wiring.</li> <li>Compressor not properly wired to control.</li> <li>Faulty compressor wiring.</li> </ul> | <ul style="list-style-type: none"> <li>Check compressor; repair/replace as needed.</li> <li>Check run capacitor; replace as needed.</li> <li>Check wiring; repair/replace as needed.</li> </ul>  | <ul style="list-style-type: none"> <li>Turn power OFF prior to repair.</li> <li>Fault will clear after 1 normal cycle.</li> <li>Fault may be cleared by cycling 24VAC to control.</li> <li>Replace with correct replacement part(s).</li> </ul> |
| <ul style="list-style-type: none"> <li>Compressor and outdoor fan are off.</li> <li>Low pressure and high pressure switches are closed.</li> <li>Open start circuit has been detected 4 times with 5 minute delay between each detection.</li> <li>Integrated control module diagnostic/status LED's display the indicated code.</li> <li>ComfortNet™ thermostat "Call for Service" icon illuminated.</li> <li>ComfortNet™ thermostat scrolls "Check Air Conditioner" or "Check Heat Pump" message.</li> </ul> | OFF                         | 6<br>Flashes | ON  | ON if call present;<br>OFF if no call | <ul style="list-style-type: none"> <li>Open Start Circuit Lockout</li> </ul> | OPEN START<br>LOCK          | 06   | <ul style="list-style-type: none"> <li>Compressor start winding is open.</li> <li>Failed compressor run capacitor.</li> <li>Faulty run capacitor wiring.</li> <li>Compressor not properly wired to control.</li> <li>Faulty compressor wiring.</li> </ul> | <ul style="list-style-type: none"> <li>Check compressor; repair/replace as needed.</li> <li>Check run capacitor; replace as needed.</li> <li>Check wiring; repair/replace as needed.</li> </ul>  | <ul style="list-style-type: none"> <li>Turn power OFF prior to repair.</li> <li>Must clear fault by cycling 24VAC to control.</li> <li>Replace with correct replacement part(s).</li> </ul>   |

# SERVICING

| Symptoms of Abnormal Operation<br>(Legacy & ComfortNet™ Thermostat)  | Diagnostic/Status LED Codes |          |     |                                       |                   | Fault Description | ComfortNet™ Thermostat Only   |   | Possible Causes  | Corrective Actions | Notes & Cautions |
|--|-----------------------------|----------|-----|---------------------------------------|-------------------|-------------------|---|---|--|--------------------|------------------|
|  | Green                       | Yellow   | Red | Red Y1                                | Message           |                   | Code  |   |  |                    |                  |
|  | OFF                         | 7 Hashes | OFF | ON if call present;<br>OFF if no call | OPEN/RUN          |                   | 07  |   |  |                    |                  |
| <ul style="list-style-type: none"> <li>Compressor and outdoor fan are off.</li> <li>Low pressure and high pressure switches are closed.</li> <li>Integrated control module diagnostic/status LED's display the indicated code.</li> <li>ComfortNet™ thermostat "Call for Service" icon illuminated.</li> <li>ComfortNet™ thermostat scrolls "Check Air Conditioner" or "Check Heat Pump" message.</li> </ul>   | OFF                         | 7 Hashes | OFF | ON if call present;<br>OFF if no call | OPEN/RUN          | 07                | <ul style="list-style-type: none"> <li>Compressor run winding is open.</li> <li>Compressor not properly wired to control.</li> <li>Faulty compressor wiring.</li> </ul> | <ul style="list-style-type: none"> <li>Check compressor; repair/replace as needed.</li> <li>Check wiring; repair/replace as needed.</li> </ul>  | <ul style="list-style-type: none"> <li>Turnpower OFF prior to repair.</li> <li>Fault will clear after 1 normal cycle.</li> <li>Fault may be cleared by cycling 24VAC to control.</li> <li>Replace with correct replacement part(s).</li> </ul> |                    |                  |
| <ul style="list-style-type: none"> <li>Compressor and outdoor fan are off.</li> <li>Low pressure and high pressure switches are closed.</li> <li>Open run circuit has been detected 4 times with 5 minute delay between each detection.</li> <li>Integrated control module diagnostic/status LED's display the indicated code.</li> <li>ComfortNet™ thermostat "Call for Service" icon illuminated.</li> <li>ComfortNet™ thermostat scrolls "Check Air Conditioner" or "Check Heat Pump" message.</li> </ul> | OFF                         | 7 Hashes | ON  | ON if call present;<br>OFF if no call | OPEN/RUN<br>LOCK  | 07                | <ul style="list-style-type: none"> <li>Compressor run winding is open.</li> <li>Compressor not properly wired to control.</li> <li>Faulty compressor wiring.</li> </ul> | <ul style="list-style-type: none"> <li>Check compressor; repair/replace as needed.</li> <li>Check wiring; repair/replace as needed.</li> </ul>  | <ul style="list-style-type: none"> <li>Turnpower OFF prior to repair.</li> <li>Must clear fault by cycling 24VAC to control.</li> <li>Replace with correct replacement part(s).</li> </ul>   |                    |                  |
| <ul style="list-style-type: none"> <li>Air conditioner/heat pump may appear to be operating normally.</li> <li>Compressor protector may be open (compressor and outdoor fan off).</li> <li>Integrated control module diagnostic/status LED's display the indicated code.</li> </ul>  | OFF                         | 8 Hashes | OFF | ON if call present;<br>OFF if no call | LOWLINE<br>VOLT   | 08                | <ul style="list-style-type: none"> <li>Low line voltage.</li> </ul>   | <ul style="list-style-type: none"> <li>Check circuit breakers and fuses.</li> <li>Verify unit is connected to power supply as specified on rating plate.</li> <li>Correct low line voltage condition; contact local utility if needed.</li> </ul>                                     | <ul style="list-style-type: none"> <li>Turnpower OFF prior to repair.</li> <li>Control detects line voltage less than 185 VAC.</li> </ul>  |                    |                  |
| <ul style="list-style-type: none"> <li>Air conditioner/heat pump may appear to be operating normally.</li> <li>Compressor protector may be open (compressor and outdoor fan off).</li> <li>Integrated control module diagnostic/status LED's display the indicated code.</li> </ul>  | ON                          | 8 Hashes | OFF | ON if call present;<br>OFF if no call | HIGH LINE<br>VOLT | 08                | <ul style="list-style-type: none"> <li>High line voltage.</li> </ul>  | <ul style="list-style-type: none"> <li>Correct high line voltage condition; contact local utility if needed.</li> <li>Verify unit is connected to power supply as specified on rating plate.</li> <li>Correct low line voltage condition; contact local utility if needed.</li> </ul> | <ul style="list-style-type: none"> <li>Turnpower OFF prior to repair.</li> <li>Control detects line voltage greater than 255 VAC.</li> </ul>   |                    |                  |



# SERVICING

| Symptoms of Abnormal Operation<br>(Legacy & CmfortNet™ Thermostat)  | Diagnostic Status LED Codes |          |     |                                       | Fault Description   | CmfortNet™ Thermostat Only |               | Possible Causes   | Corrective Actions   | Notes & Cautions   |
|---|-----------------------------|----------|-----|---------------------------------------|---|----------------------------|---------------|---|--|--|
|   | Green                       | Yellow   | Red | Red Y1                                |   | Message                    | Code          |   |  |  |
|   |                             |          |     |                                       |   |                            |               |   |  |  |
| <ul style="list-style-type: none"> <li>Air conditioner/heat pump may appear to be operating normally.</li> <li>Integrated control module diagnostic/status LED's display the indicated code.</li> </ul> | OFF                         | 9 Hashes | OFF | ON if call present;<br>OFF if no call | <ul style="list-style-type: none"> <li>Low Pilot Voltage</li> </ul>   | LOW SECOND VOLT            | 09            | <ul style="list-style-type: none"> <li>Control detects secondary voltage less than 18 VAC</li> <li>Transformer overloaded</li> <li>Low line voltage.</li> </ul>   | <ul style="list-style-type: none"> <li>Check fuse</li> <li>Correct low secondary voltage condition</li> <li>Check transformer; replace if needed</li> </ul>                                    | <ul style="list-style-type: none"> <li>Turnpower OFF prior to repair.</li> <li>Fault will clear if secondary voltage rises above 21 VAC.</li> <li>Replace with correct replacement part(s).</li> </ul>   |
| <ul style="list-style-type: none"> <li>Compressor is off.</li> <li>Integrated control module diagnostic/status LED's display the indicated code.</li> </ul>   | OFF                         | ON       | ON  | ON if call present;<br>OFF if no call | <ul style="list-style-type: none"> <li>Comp Protector Open</li> </ul> | Not displayed              | Not displayed | <ul style="list-style-type: none"> <li>No current through run or start windings</li> <li>Compressor run winding is open</li> <li>Compressor not properly wired to control.</li> <li>Faulty compressor wiring</li> <li>Failed compressor run capacitor.</li> <li>Faulty run capacitor wiring.</li> </ul> | <ul style="list-style-type: none"> <li>Check compressor; repair/replace as needed.</li> <li>Check wiring; repair/replace as needed.</li> <li>Check run capacitor; replace as needed</li> </ul> | <ul style="list-style-type: none"> <li>Turnpower OFF prior to repair.</li> <li>Fault will clear after 1 normal cycle.</li> <li>Fault may be cleared by cycling 24VAC to control.</li> <li>Replace with correct replacement part(s).</li> </ul> |

## SYSTEM TROUBLESHOOTING

| UNITARY DIAGNOSTIC CODES  |                                     |         |         |   |                             |      |   |  |  |
|---|-------------------------------------|---------|---------|---|-----------------------------|------|---|--|--|
| Symptoms of Abnormal Operation (Legacy & ComfortNet™ Thermostat)  | Diagnostic/Status LED Display Codes |         |         | Fault Description   | ComfortNet™ Thermostat Only |      | Possible Causes   | Corrective Actions   | Notes & Cautions   |
|   | Digit 3                             | Digit 2 | Digit 1 |   | Message                     | Code |   |  |  |
| <ul style="list-style-type: none"> <li>Integrated control module diagnostic/status LED display shows the indicated code.</li> <li>ComfortNet™ thermostat displays '---' in the temperature display area.</li> </ul>   | BLANK                               | A       | 2       | <ul style="list-style-type: none"> <li>Outdoor air temp sensor fault</li> </ul>                                     | AIR SENSOR FLT              | A2   | <ul style="list-style-type: none"> <li>Shorted sensor.</li> <li>Open sensor.</li> <li>Sensor disconnected.</li> <li>Sensor out of range.</li> </ul>   | <ul style="list-style-type: none"> <li>Check sensor connection.</li> <li>Replace open/shorted sensor.</li> </ul>   | <ul style="list-style-type: none"> <li>Turn power OFF prior to repair.</li> <li>Replace with correct replacement part.</li> </ul>  |
| <ul style="list-style-type: none"> <li>Heat pump fails to operate in heating mode.</li> <li>Integrated control module diagnostic/status LED display shows the indicated code.</li> <li>ComfortNet™ thermostat displays error message.</li> </ul>  | BLANK                               | A       | 3       | <ul style="list-style-type: none"> <li>Outdoor coil temp sensor fault</li> </ul>                                    | COIL SENSOR FLT             | A3   | <ul style="list-style-type: none"> <li>Shorted sensor</li> <li>Open sensor.</li> <li>Sensor disconnected.</li> <li>Sensor out of range.</li> </ul>  | <ul style="list-style-type: none"> <li>Check sensor connection.</li> <li>Replace open/shorted sensor.</li> </ul>   | <ul style="list-style-type: none"> <li>Turn power OFF prior to repair.</li> <li>Replace with correct replacement part.</li> </ul>  |
| <ul style="list-style-type: none"> <li>Air conditioner/heat pump fails to operate.</li> <li>Integrated control module diagnostic/status LED display shows the indicated code.</li> </ul>  | BLANK                               | E       | 5       | <ul style="list-style-type: none"> <li>Open fuse</li> </ul>   | BLOWN FUSE                  | E5   | <ul style="list-style-type: none"> <li>Short in low voltage wiring.</li> </ul>  | <ul style="list-style-type: none"> <li>Locate and correct short in low voltage wiring.</li> </ul>  | <ul style="list-style-type: none"> <li>Turn power OFF prior to repair.</li> <li>Replace fuse with 3-amp automotive type.</li> </ul>  |
| <ul style="list-style-type: none"> <li>Air conditioner/heat pump fails to operate.</li> <li>Integrated control module diagnostic/status LED display shows the indicated code.</li> </ul>  | BLANK                               | E       | E       | <ul style="list-style-type: none"> <li>Board mis-operation</li> </ul>   | INTERNAL FAULT              | EE   | <ul style="list-style-type: none"> <li>Compressor relay contacts welded.</li> </ul>   | <ul style="list-style-type: none"> <li>Replace control.</li> </ul>   | <ul style="list-style-type: none"> <li>Turn power OFF prior to repair</li> <li>Replace with correct replacement part.</li> </ul>   |
| <ul style="list-style-type: none"> <li>Air conditioner/heat pump fails to operate.</li> <li>Integrated control module diagnostic/status LED display shows the indicated code.</li> <li>ComfortNet™ thermostat displays error message.</li> </ul>  | BLANK                               | b       | 0       | <ul style="list-style-type: none"> <li>Circulator blower motor is not running when it should be running.</li> </ul> | MOTOR NOT RUN               | b0   | <ul style="list-style-type: none"> <li>Indoor blower motor problem.</li> <li>Communications error between indoor and outdoor unit.</li> </ul>   | <ul style="list-style-type: none"> <li>Check indoor blower motor.</li> <li>Check indoor blower motor wiring.</li> <li>Check indoor unit control.</li> <li>Repair/ replace any faulty wiring.</li> <li>Repair/ replace indoor blower motor or control.</li> </ul> | <ul style="list-style-type: none"> <li>Turn power OFF prior to repair.</li> <li>Applies only to fully communicating system using ComfortNet™ thermostat.</li> <li>Replace with correct replacement part.</li> </ul>  |
| <ul style="list-style-type: none"> <li>Air conditioner/heat pump operates at reduced performance.</li> <li>Air conditioner/heat pump operating at low stage when expected to operate at high stage.</li> <li>Integrated control module diagnostic/status LED display shows the indicated code.</li> </ul> | BLANK                               | b       | 9       | <ul style="list-style-type: none"> <li>Airflow is lower than demanded</li> </ul>                                    | LOW ID AIRFLOW              | b9   | <ul style="list-style-type: none"> <li>Indoor blower motor problem</li> <li>Blocked filters.</li> <li>Restrictive/ undersized ductwork</li> <li>Indoor/ outdoor unit miss-match.</li> </ul> | <ul style="list-style-type: none"> <li>Check indoor blower motor.</li> <li>Check filters; clean/replace as needed.</li> <li>Check ductwork; resize as needed.</li> <li>Verify indoor and outdoor units are properly matched.</li> </ul>                          | <ul style="list-style-type: none"> <li>Turn power OFF prior to repair.</li> <li>Applies only to fully communicating system using ComfortNet™ thermostat.</li> <li>Replace with correct replacement part. See specification sheet(s) for airflow requirements and maximum external static pressure.</li> <li>See specification sheets for approved system matches.</li> </ul> |

| UNITARY DIAGNOSTIC CODES  |                                     |         |         |   |                             |      |   |  |   |
|---|-------------------------------------|---------|---------|---|-----------------------------|------|---|--|---|
| Symptoms of Abnormal Operation (Legacy & ComfortNet™ Thermostat)  | Diagnostic/Status LED Display Codes |         |         | Fault Description   | ComfortNet™ Thermostat Only |      | Possible Causes   | Corrective Actions   | Notes & Cautions  |
|   | Digit 3                             | Digit 2 | Digit 1 |   | Message                     | Code |   |  |   |
| <ul style="list-style-type: none"> <li>Air conditioner/heat pump fails to operate.</li> <li>Integrated control module diagnostic/status LED display shows the indicated code.</li> <li>ComfortNet™ thermostat displays error message.</li> </ul>  | BLANK                               | d       | 0       | <ul style="list-style-type: none"> <li>Data not yet on Network</li> </ul> | NO NET DATA                 | d0   | <ul style="list-style-type: none"> <li>Air conditioner/heat pump is wired as part of a communicating system and integrated control module does not contain any shared data.</li> </ul>  | <ul style="list-style-type: none"> <li>Verify system type (communicating or legacy)</li> <li>Populate shared data using memory card</li> <li>Wire system as legacy system</li> </ul>   | <ul style="list-style-type: none"> <li>Turn power OFF prior to repair.</li> <li>Use memory card for your specific model.</li> <li>Insert memory card BEFORE turning power ON. Memory card may be removed after data is loaded. Turn power OFF before removing memory card.</li> <li>Error code will be cleared once data is loaded. Applies only to fully communicating system using ComfortNet™ thermostat.</li> </ul> |
| <ul style="list-style-type: none"> <li>Air conditioner/heat pump fails to operate.</li> <li>Integrated control module diagnostic/status LED display shows the indicated code.</li> <li>ComfortNet™ thermostat displays error message.</li> </ul>  | BLANK                               | d       | 1       | <ul style="list-style-type: none"> <li>Invalid Data on Network</li> </ul> | INVALID DATA                | d1   | <ul style="list-style-type: none"> <li>Air conditioner/heat pump is wired as part of a communicating system and integrated control module contains invalid shared data or network data is invalid for the integrated control module.</li> </ul>                                     | <ul style="list-style-type: none"> <li>Verify system type (communicating or legacy).</li> <li>Populate correct shared data using memory card.</li> <li>Wire system as legacy system.</li> </ul>                                      | <ul style="list-style-type: none"> <li>Turn power OFF prior to repair.</li> <li>Use memory card for your specific model.</li> <li>Insert memory card BEFORE turning power ON. Memory card may be removed after data is loaded. Turn power OFF before removing memory card.</li> <li>Error code will be cleared once data is loaded. Applies only to fully communicating system using ComfortNet™ thermostat.</li> </ul> |
| <ul style="list-style-type: none"> <li>Air conditioner/heat pump fails to operate.</li> <li>Air conditioner/heat pump operating at reduced performance.</li> <li>Air conditioner/heat pump operating at low stage when expected to operate at high stage.</li> <li>Integrated control module diagnostic/status LED display shows the indicated code.</li> <li>ComfortNet™ thermostat displays error message.</li> </ul> | BLANK                               | d       | 2       | <ul style="list-style-type: none"> <li>System Mis-Match</li> </ul>        | INVALID SYSTEM              | d2   | <ul style="list-style-type: none"> <li>Air conditioner/heat pump is wired as part of a communicating system and outdoor unit requires airflow greater than indoor unit's airflow capability.</li> <li>Shared data is incompatible with the system or missing parameters.</li> </ul> | <ul style="list-style-type: none"> <li>Verify system type (communicating or legacy).</li> <li>Verify shared data is correct for your specific model; re-populate data if required.</li> <li>Wire system as legacy system.</li> </ul> | <ul style="list-style-type: none"> <li>Turn power OFF prior to repair.</li> <li>Use memory card for your specific model.</li> <li>Insert memory card BEFORE turning power ON. Memory card may be removed after data is loaded. Turn power OFF before removing memory card.</li> <li>Error code will be cleared once data is loaded. Applies only to fully communicating system using ComfortNet™ thermostat.</li> </ul> |

| UNITARY DIAGNOSTIC CODES   |                                     |         |         |   |                             |      |  |   |   |
|--|-------------------------------------|---------|---------|---|-----------------------------|------|--|---|---|
| Symptoms of Abnormal Operation (Legacy & ComfortNet™ Thermostat)   | Diagnostic/Status LED Display Codes |         |         | Fault Description   | ComfortNet™ Thermostat Only |      | Possible Causes  | Corrective Actions  | Notes & Cautions  |
|  | Digit 3                             | Digit 2 | Digit 1 |   | Message                     | Code |  |   |   |
| <ul style="list-style-type: none"> <li>Air conditioner/heat pump fails to operate.</li> <li>Integrated control module diagnostic/status LED display shows the indicated code.</li> <li>ComfortNet™ thermostat displays error message.</li> </ul>   | BLANK                               | d       | 3       | <ul style="list-style-type: none"> <li>Configuration Mis-match</li> </ul>   | INVALID CONFIG              | d3   | <ul style="list-style-type: none"> <li>Shared data sent to integrated control module does not match hardware configuration.</li> </ul>   | <ul style="list-style-type: none"> <li>Verify system type (communicating or legacy).</li> <li>Verify shared data is correct for your specific model; re-populate data if required.</li> <li>Wire system as legacy system.</li> </ul>  | <ul style="list-style-type: none"> <li>Turn power OFF prior to repair.</li> <li>Use memory card for your specific model.</li> <li>Insert memory card BEFORE turning power ON. Memory card may be removed after data is loaded. Turn power OFF before removing memory card.</li> <li>Error code will be cleared once data is loaded. Applies only to fully communicating system using ComfortNet™ thermostat.</li> </ul> |
| <ul style="list-style-type: none"> <li>Air conditioner/heat pump fails to operate.</li> <li>Integrated control module diagnostic/status LED display shows the indicated code.</li> <li>ComfortNet™ thermostat displays error message.</li> </ul>   | BLANK                               | d       | 4       | <ul style="list-style-type: none"> <li>Invalid Memory Card Data</li> </ul>  | INVALID MC DATA             | d4   | <ul style="list-style-type: none"> <li>Shared data on memory card has been rejected.</li> </ul>  | <ul style="list-style-type: none"> <li>Verify system type (communicating or legacy).</li> <li>Verify shared data is correct for your specific model; re-populate data if required.</li> <li>Wire system as legacy system.</li> </ul>  | <ul style="list-style-type: none"> <li>Turn power OFF prior to repair.</li> <li>Use memory card for your specific model.</li> <li>Insert memory card BEFORE turning power ON. Memory card may be removed after data is loaded. Turn power OFF before removing memory card.</li> <li>Error code will be cleared once data is loaded.</li> </ul>  |
| <ul style="list-style-type: none"> <li>Very long run time.</li> <li>Four consecutive compressor protector trips with average run time between trips greater than 3 hours.</li> <li>Compressor operating at high speed and outdoor fan operating at low speed</li> <li>Integrated control module diagnostic/status LED display shows the indicated code.</li> </ul> | BLANK                               | 0       | 1       | <ul style="list-style-type: none"> <li>Low Side Fault</li> </ul>            | LOW SIDE FAULT              | 01   | <ul style="list-style-type: none"> <li>Low refrigerant charge.</li> <li>Restriction in liquid line.</li> <li>Indoor blower motor failure.</li> <li>Indoor thermostat set extremely low.</li> </ul> | <ul style="list-style-type: none"> <li>Verify refrigerant charge; adjust as needed.</li> <li>Check for restricted liquid line; repair/replace as needed.</li> <li>Check indoor blower motor; repair/replace as needed.</li> <li>Check indoor thermostat setting.</li> </ul>   | <ul style="list-style-type: none"> <li>Turn power OFF prior to repair.</li> <li>Fault will clear after 30 consecutive normal cycles.</li> <li>Fault may be cleared by cycling 24VAC to control.</li> <li>Replace with correct replacement part(s).</li> </ul>   |
| <ul style="list-style-type: none"> <li>Compressor and outdoor fan are off.</li> <li>Thermostat demand is present.</li> <li>Integrated control module diagnostic/status LED display shows the indicated code.</li> </ul>  | BLANK                               | 0       | 1       | <ul style="list-style-type: none"> <li>Low Pressure Cut Out Trip</li> </ul> | LPS OPEN                    | 01   | <ul style="list-style-type: none"> <li>Low refrigerant charge.</li> <li>Restriction in liquid line.</li> <li>Indoor blower motor failure.</li> <li>Indoor thermostat set extremely low.</li> </ul> | <ul style="list-style-type: none"> <li>Verify refrigerant charge; adjust as needed.</li> <li>Check for restricted liquid line; repair/replace as needed.</li> <li>Check indoor blower motor; repair/replace as needed.</li> <li>Check low pressure switch; repair/replace as needed.</li> <li>Check indoor thermostat setting.</li> </ul> | <ul style="list-style-type: none"> <li>Turn power OFF prior to repair.</li> <li>Replace with correct replacement part(s).</li> </ul>  |

| UNITARY DIAGNOSTIC CODES  |                                     |         |         |   |                             |      |  |   |  |
|---|-------------------------------------|---------|---------|---|-----------------------------|------|--|---|--|
| Symptoms of Abnormal Operation (Legacy & ComfortNet™ Thermostat)  | Diagnostic/Status LED Display Codes |         |         | Fault Description   | ComfortNet™ Thermostat Only |      | Possible Causes  | Corrective Actions  | Notes & Cautions   |
|   | Digit 3                             | Digit 2 | Digit 1 |   | Message                     | Code |  |   |  |
| <ul style="list-style-type: none"> <li>Compressor and outdoor fan are off .</li> <li>Low pressure switch trip 3 times within same thermostat demand.</li> <li>Thermostat demand is present.</li> <li>Integrated control module diagnostic/status LED display shows the indicated code.</li> <li>ComfortNet™ thermostat displays error message.</li> </ul> | BLANK                               | L       | 1       | <ul style="list-style-type: none"> <li>Low Pressure Cut Out Lockout (3 Trips)</li> </ul>  | LPS LOCKOUT                 | 01   | <ul style="list-style-type: none"> <li>Low refrigerant charge.</li> <li>Restriction in liquid line.</li> <li>Indoor blower motor failure.</li> <li>Indoor thermostat set extremely low.</li> </ul> | <ul style="list-style-type: none"> <li>Verify refrigerant charge; adjust as needed.</li> <li>Check for restricted liquid line; repair/replace as needed.</li> <li>Check indoor blower motor; repair/replace as needed.</li> <li>Check low pressure switch; repair/replace as needed.</li> <li>Check indoor thermostat setting.</li> </ul> | <ul style="list-style-type: none"> <li>Turn power OFF prior to repair.</li> <li>Must clear fault by cycling 24VAC to control.</li> <li>Replace with correct replacement part(s).</li> </ul>  |
| <ul style="list-style-type: none"> <li>Four consecutive compressor protector trips with average run time between trips greater than 1 minute and less than 15 minutes.</li> <li>Low pressure and high pressure switches are closed.</li> <li>Integrated control module diagnostic/status LED display shows the indicated code.</li> </ul>                 | BLANK                               | 0       | 2       | <ul style="list-style-type: none"> <li>High Side Fault</li> </ul>                         | HIGH SIDE FAULT             | 02   | <ul style="list-style-type: none"> <li>Blocked condenser coil.</li> <li>Outdoor fan not running.</li> </ul>  | <ul style="list-style-type: none"> <li>Check and clean condenser coil.</li> <li>Check outdoor fan motor; repair/replace as needed.</li> <li>Check outdoor fan motor wiring; repair/replace as needed.</li> <li>Check outdoor fan motor capacitor; replace as needed.</li> </ul>   | <ul style="list-style-type: none"> <li>Turn power OFF prior to repair.</li> <li>Fault will clear after 4 consecutive normal cycles.</li> <li>Fault may be cleared by cycling 24VAC to control.</li> <li>Replace with correct replacement part(s).</li> </ul> |
| <ul style="list-style-type: none"> <li>Compressor and outdoor fan are off .</li> <li>Thermostat demand is present.</li> <li>Integrated control module diagnostic/status LED display shows the indicated code.</li> </ul>  | BLANK                               | 0       | 2       | <ul style="list-style-type: none"> <li>High Pressure Cut Out Trip</li> </ul>              | HPS OPEN                    | 02   | <ul style="list-style-type: none"> <li>Blocked condenser coil.</li> <li>Outdoor fan not running.</li> </ul>  | <ul style="list-style-type: none"> <li>Check and clean condenser coil.</li> <li>Check outdoor fan motor; repair/replace as needed.</li> <li>Check outdoor fan motor wiring; repair/replace as needed.</li> <li>Check outdoor fan motor capacitor; replace as needed.</li> </ul>   | <ul style="list-style-type: none"> <li>Turn power OFF prior to repair.</li> <li>Replace with correct replacement part(s).</li> </ul>   |
| <ul style="list-style-type: none"> <li>Compressor and outdoor fan are off .</li> <li>Low pressure switch trip 3 times within same thermostat demand.</li> <li>Thermostat demand is present.</li> <li>Integrated control module diagnostic/status LED display shows the indicated code.</li> <li>ComfortNet™ thermostat displays error message.</li> </ul> | BLANK                               | L       | 2       | <ul style="list-style-type: none"> <li>High Pressure Cut Out Lockout (3 Trips)</li> </ul> | HPS LOCKOUT                 | 02   | <ul style="list-style-type: none"> <li>Blocked condenser coil.</li> <li>Outdoor fan not running.</li> </ul>  | <ul style="list-style-type: none"> <li>Check and clean condenser coil.</li> <li>Check outdoor fan motor; repair/replace as needed.</li> <li>Check outdoor fan motor wiring; repair/replace as needed.</li> <li>Check outdoor fan motor capacitor; replace as needed.</li> </ul>   | <ul style="list-style-type: none"> <li>Turn power OFF prior to repair.</li> <li>Must clear fault by cycling 24VAC to control.</li> <li>Replace with correct replacement part(s).</li> </ul>  |

| UNITARY DIAGNOSTIC CODES   |                                     |         |         |                      |                             |      |   |  |  |
|--|-------------------------------------|---------|---------|----------------------|-----------------------------|------|---|--|--|
| Symptoms of Abnormal Operation (Legacy & ComfortNet™ Thermostat)   | Diagnostic/Status LED Display Codes |         |         | Fault Description    | ComfortNet™ Thermostat Only |      | Possible Causes   | Corrective Actions   | Notes & Cautions   |
|  | Digit 3                             | Digit 2 | Digit 1 |                      | Message                     | Code |   |  |  |
| <ul style="list-style-type: none"> <li>Run time for last 4 cycles is less than 3 minutes each.</li> <li>Compressor protector has not tripped.</li> <li>Low pressure and high pressure switches are closed.</li> <li>Integrated control module diagnostic/status LED display shows the indicated code.</li> </ul>   | BLANK                               | 0       | 3       | • Short Cycling      | CMPR SHRT CYCLE             | 03   | <ul style="list-style-type: none"> <li>Intermittent thermostat demand.</li> <li>Faulty compressor relay.</li> </ul>   | <ul style="list-style-type: none"> <li>Check thermostat and thermostat wiring; repair/replace as needed.</li> <li>Check compressor relay operation; replace control as needed.</li> </ul>  | <ul style="list-style-type: none"> <li>Turn power OFF prior to repair.</li> <li>Fault will clear after 4 consecutive normal cycles.</li> <li>Fault may be cleared by cycling 24VAC to control.</li> <li>Replace with correct replacement part(s).</li> <li>Minimum compressor run time is changed from 30 seconds to 3 minutes.</li> </ul> |
| <ul style="list-style-type: none"> <li>Compressor and outdoor fan are off .</li> <li>Compressor protector trips four consecutive times.</li> <li>Average run time between trips is less than 15 seconds.</li> <li>Integrated control module diagnostic/status LED display shows the indicated code.</li> <li>ComfortNet™ thermostat displays error message.</li> </ul> | BLANK                               | 0       | 4       | • Locked Rotor       | LOCKED ROTOR                | 04   | <ul style="list-style-type: none"> <li>Compressor bearings are seized.</li> <li>Failed compressor run capacitor.</li> <li>Faulty run capacitor wiring.</li> <li>Low line voltage.</li> </ul>  | <ul style="list-style-type: none"> <li>Check compressor operation; repair/replace as needed.</li> <li>Check run capacitor; replace as needed.</li> <li>Check wiring; repair/replace as needed.</li> <li>Verify line voltage is within range on rating plate; contact local utility is out of range.</li> </ul> | <ul style="list-style-type: none"> <li>Turn power OFF prior to repair.</li> <li>Must clear fault by cycling 24VAC to control.</li> <li>Replace with correct replacement part(s).</li> </ul>  |
| <ul style="list-style-type: none"> <li>Compressor and outdoor fan are off f or greater than 4 hours.</li> <li>Low pressure and high pressure switches are closed.</li> <li>Integrated control module diagnostic/status LED display shows the indicated code.</li> <li>ComfortNet™ thermostat displays error message.</li> </ul>  | BLANK                               | 0       | 5       | • Open Circuit       | OPEN CIRCUIT                | 05   | <ul style="list-style-type: none"> <li>Power is disconnected.</li> <li>Failed compressor protector.</li> <li>Compressor not properly wired to control.</li> </ul>   | <ul style="list-style-type: none"> <li>Check circuit breakers and fuses.</li> <li>Check wiring to unit; repair/replace as needed.</li> <li>Check compressor; repair/replace as needed</li> <li>Check compressor wiring; repair/replace as needed.</li> </ul>   | <ul style="list-style-type: none"> <li>Turn power OFF prior to repair.</li> <li>Fault will clear after 1 normal cycle.</li> <li>Fault may be cleared by cycling 24VAC to control.</li> <li>Replace with correct replacement part(s).</li> </ul>  |
| <ul style="list-style-type: none"> <li>Compressor and outdoor fan are off .</li> <li>Low pressure and high pressure switches are closed.</li> <li>Integrated control module diagnostic/status LED display shows the indicated code.</li> <li>ComfortNet™ thermostat displays error message.</li> </ul>   | BLANK                               | 0       | 6       | • Open Start Circuit | OPEN START                  | 06   | <ul style="list-style-type: none"> <li>Compressor start winding is open.</li> <li>Failed compressor run capacitor.</li> <li>Faulty run capacitor wiring.</li> <li>Compressor not properly wired to control.</li> <li>Faulty compressor wiring.</li> </ul> | <ul style="list-style-type: none"> <li>Check compressor; repair/replace as needed.</li> <li>Check run capacitor; replace as needed.</li> <li>Check wiring; repair/replace as needed.</li> </ul>  | <ul style="list-style-type: none"> <li>Turn power OFF prior to repair.</li> <li>Fault will clear after 1 normal cycle.</li> <li>Fault may be cleared by cycling 24VAC to control.</li> <li>Replace will correct replacement part(s).</li> </ul>  |

| UNITARY DIAGNOSTIC CODES   |                                     |         |         |  |                             |      |   |   |  |
|--|-------------------------------------|---------|---------|--|-----------------------------|------|---|---|--|
| Symptoms of Abnormal Operation (Legacy & ComfortNet™ Thermostat)   | Diagnostic/Status LED Display Codes |         |         | Fault Description  | ComfortNet™ Thermostat Only |      | Possible Causes   | Corrective Actions  | Notes & Cautions   |
|  | Digit 3                             | Digit 2 | Digit 1 |  | Message                     | Code |   |   |  |
| <ul style="list-style-type: none"> <li>Compressor and outdoor fan are off .</li> <li>Low pressure and high pressure switches are closed.</li> <li>Open start circuit has been detected 4 times with 5 minute delay between each detection.</li> <li>Integrated control module diagnostic/status LED display shows the indicated code.</li> <li>ComfortNet™ thermostat displays error message.</li> </ul> | BLANK                               | L       | 6       | <ul style="list-style-type: none"> <li>Open Start Circuit Lockout</li> </ul> | OPEN START LOCK             | 06   | <ul style="list-style-type: none"> <li>Compressor start winding is open.</li> <li>Failed compressor run capacitor.</li> <li>Faulty run capacitor wiring.</li> <li>Compressor not properly wired to control.</li> <li>Faulty compressor wiring.</li> </ul> | <ul style="list-style-type: none"> <li>Check compressor; repair/replace as needed.</li> <li>Check run capacitor; replace as needed.</li> <li>Check wiring repair/replaced as needed.</li> </ul>   | <ul style="list-style-type: none"> <li>Turn power OFF prior to repair</li> <li>Must clear fault by cycling 24VAC to control.</li> <li>Replace with correct replacement part(s).</li> </ul>   |
| <ul style="list-style-type: none"> <li>Compressor and outdoor fan are off .</li> <li>Low pressure and high pressure switches are closed.</li> <li>Integrated control module diagnostic/status LED display shows the indicated code.</li> <li>ComfortNet™ thermostat displays error message.</li> </ul>   | BLANK                               | 0       | 7       | <ul style="list-style-type: none"> <li>Open Run Circuit</li> </ul>           | OPEN RUN                    | 07   | <ul style="list-style-type: none"> <li>Compressor run winding is open.</li> <li>Compressor not properly wired to control.</li> <li>Faulty compressor wiring.</li> </ul>   | <ul style="list-style-type: none"> <li>Check compressor; repair/replace as needed.</li> <li>Check wiring; repair/replace as needed.</li> </ul>  | <ul style="list-style-type: none"> <li>Turn power OFF prior to repair.</li> <li>Fault will clear after 1 normal cycle.</li> <li>Fault may be cycling 24VAC to control.</li> <li>Replace with correct replacement part(s).</li> </ul> |
| <ul style="list-style-type: none"> <li>Compressor and outdoor fan are off .</li> <li>Low pressure and high pressure switches are closed.</li> <li>Open run circuit has been detected 4 times with 5 minute delay between each detection.</li> <li>Integrated control module diagnostic/status LED display shows the indicated code.</li> <li>ComfortNet™ thermostat displays error message.</li> </ul>   | BLANK                               | L       | 7       | <ul style="list-style-type: none"> <li>Open Run Circuit Lockout</li> </ul>   | OPEN RUN LOCK               | 07   | <ul style="list-style-type: none"> <li>Compressor run winding is open.</li> <li>Compressor not properly wired to control.</li> <li>Faulty compressor wiring.</li> </ul>   | <ul style="list-style-type: none"> <li>Check compressor; repair/replace as needed.</li> <li>Check wiring; repair/replace as needed.</li> </ul>  | <ul style="list-style-type: none"> <li>Turn power OFF prior to repair.</li> <li>Must clear fault by cycling 24VAC to control.</li> <li>Replace with correct replacement part(s).</li> </ul>  |
| <ul style="list-style-type: none"> <li>Air conditioner/heat pump may appear to be operating normally.</li> <li>Compressor protector may be open (compressor and outdoor fan off).</li> <li>Integrated control module diagnostic/status LED display shows the indicated code.</li> </ul>  | BLANK                               | L       | 8       | <ul style="list-style-type: none"> <li>Low Line Voltage</li> </ul>           | LOW LINE VOLT               | 08   | <ul style="list-style-type: none"> <li>Low line voltage.</li> </ul>   | <ul style="list-style-type: none"> <li>Check circuit breakers and fuses.</li> <li>Verify unit is connected to power supply as specified on rating plate.</li> <li>Correct low line voltage condition; contact local utility if needed.</li> </ul> | <ul style="list-style-type: none"> <li>Turn power OFF prior to repair.</li> <li>Control detects line voltage less than 185 VAC.</li> <li>Fault will clear if line voltage increases above 185 VAC.</li> </ul>                        |

| UNITARY DIAGNOSTIC CODES  |                                     |         |         |   |                             |               |  |   |   |
|---|-------------------------------------|---------|---------|---|-----------------------------|---------------|--|---|---|
| Symptoms of Abnormal Operation (Legacy & ComfortNet™ Thermostat)  | Diagnostic/Status LED Display Codes |         |         | Fault Description   | ComfortNet™ Thermostat Only |               | Possible Causes  | Corrective Actions  | Notes & Cautions  |
|   | Digit 3                             | Digit 2 | Digit 1 |   | Message                     | Code          |  |   |   |
| <ul style="list-style-type: none"> <li>Air conditioner/heat pump may appear to be operating normally.</li> <li>Compressor protector may be open (compressor and outdoor fan off).</li> <li>Integrated control module diagnostic/status LED display shows the indicated code.</li> </ul> | BLANK                               | H       | 8       | <ul style="list-style-type: none"> <li>High Line Voltage</li> </ul>   | HIGH LINE VOLT              | 08            | <ul style="list-style-type: none"> <li>High line voltage</li> </ul>  | <ul style="list-style-type: none"> <li>Correct high line voltage condition; contact local utility if needed.</li> <li>Verify unit is connected to power supply as specified on rating plate.</li> </ul> | <ul style="list-style-type: none"> <li>Turn power OFF prior to repair.</li> <li>Control detects line voltage greater than 255 VAC.</li> <li>Fault will clear if line voltage decreases below 255 VAC.</li> </ul>                                |
| <ul style="list-style-type: none"> <li>Air conditioner/heat pump may appear to be operating normally.</li> <li>Integrated control module diagnostic/status LED display shows the indicated code.</li> </ul>   | BLANK                               | 0       | 9       | <ul style="list-style-type: none"> <li>Low Pilot Voltage</li> </ul>   | LOW SECOND VOLT             | 09            | <ul style="list-style-type: none"> <li>Control detects secondary voltage less than 18 VAC.</li> <li>Transformer overloaded.</li> <li>Low line voltage.</li> </ul>  | <ul style="list-style-type: none"> <li>Check fuse.</li> <li>Correct low secondary voltage condition.</li> <li>Check transformer; replace if needed.</li> </ul>  | <ul style="list-style-type: none"> <li>Turn power OFF prior to repair.</li> <li>Fault will clear if secondary voltage rises above 21VAC.</li> <li>Replace with correct replacement part(s).</li> </ul>  |
| <ul style="list-style-type: none"> <li>Compressor is off .</li> <li>Integrated control module diagnostic/status LED display shows the indicated code.</li> </ul>  | BLANK                               | P       | 0       | <ul style="list-style-type: none"> <li>Comp Protector Open</li> </ul> | Not displayed               | Not displayed | <ul style="list-style-type: none"> <li>No current through run or start windings.</li> <li>Compressor run winding is open.</li> <li>Compressor not properly wired to control.</li> <li>Faulty compressor wiring.</li> <li>Failed compressor run capacitor.</li> <li>Faulty run capacitor wiring.</li> </ul> | <ul style="list-style-type: none"> <li>Check compressor; repair/replace as needed.</li> <li>Check wiring; repair/replace as needed.</li> <li>Check run capacitor; replace as needed.</li> </ul>         | <ul style="list-style-type: none"> <li>Turn power OFF prior to repair.</li> <li>Fault will clear after 1 normal cycle.</li> <li>Fault may be cleared by cycling 24VAC to control.</li> <li>Replace with correct replacement part(s).</li> </ul> |
| <ul style="list-style-type: none"> <li>Air conditioner/heat pump may appear to be operating normally.</li> <li>Compressor protector may be open (compressor and outdoor fan off).</li> <li>Integrated control module diagnostic/status LED display shows the indicated code.</li> </ul> | BLANK                               | 0       | 8       | <ul style="list-style-type: none"> <li>No Line Voltage</li> </ul>     | NO LINE VOLTAGE             | 08            | <ul style="list-style-type: none"> <li>No Line Voltage</li> </ul>  | <ul style="list-style-type: none"> <li>Check circuit breaker and fuses.</li> <li>Verify unit is connected to power supply as specified on rating plate.</li> </ul>                                      | <ul style="list-style-type: none"> <li>Turn power OFF prior to repair.</li> <li>Control detects line voltage less than 185 VAC.</li> <li>Fault will clear if line voltage increases above 185 VAC.</li> </ul>                                   |



| 7 SEGMENT LED (DS2) | 7 SEGMENT LED (DS1) | DESCRIPTION OF CONDITION         |
|---------------------|---------------------|----------------------------------|
| 0                   | n                   | Standby                          |
| 0                   | 1                   | Low Pressure CO Trip             |
| 0                   | 1                   | Low Side Fault                   |
| 0                   | 2                   | High Pressure CO Trip            |
| 0                   | 2                   | High Side Fault                  |
| 0                   | 3                   | Short Cycling                    |
| 0                   | 4                   | Locked Rotor                     |
| 0                   | 5                   | Open Circuit                     |
| 0                   | 6                   | Open Start Circuit               |
| 0                   | 7                   | Open Run Circuit                 |
| 0                   | 8                   | No Line Voltage                  |
| 0                   | 9                   | Low Pilot Voltage                |
| 8                   | 8                   | Power Up                         |
| A                   | 2                   | Outdoor Air Temp Sensor Fault    |
| A                   | 3                   | Outdoor Coil Temp Sensor Fault * |
| b                   | 0                   | No Indoor Airflow                |
| b                   | 9                   | Inadequate Airflow               |
| C                   | 3                   | Cool Mode Short Cycle Timer      |
| C                   | 1                   | Low Cool                         |
| C                   | 2                   | High Cool                        |
| d                   | F                   | Defrost *                        |
| d                   | t                   | Max Defrost Time *               |
| d                   | E                   | Forced Defrost *                 |
| d                   | 0                   | Data not yet on Netw ork         |
| d                   | 1                   | Invalid Data on Netw ork         |
| d                   | 2                   | System Mis-Match                 |
| d                   | 3                   | Configuration Mis-Match          |
| d                   | 4                   | Invalid Memory Card Data         |
| E                   | E                   | Board Misoperation               |
| E                   | 5                   | Open Fuse                        |
| F                   | t                   | Field Test Mode                  |
| H                   | 8                   | High Line Voltage                |
| L                   | 1                   | LPCO Lockout (3 Trips)           |
| L                   | 2                   | HPCO Lockout (3 Trips)           |
| L                   | 6                   | Open Start Circuit Lockout       |
| L                   | 7                   | Open Run Circuit Lockout         |
| L                   | 8                   | Low Line Voltage                 |
| P                   | 3                   | Heat Mode Short Cycle Timer *    |
| P                   | 1                   | Low Heat *                       |
| P                   | 2                   | High Heat *                      |
| P                   | 0                   | Comp Protector Open              |
| P                   | d                   | Pump Dow n                       |

\* CODE USED ON HEAT PUMP MODELS ONLY  
 NOTE 1: DS1, DS2 AND DS3 ARE LABELED ON THE CONTROL ABOVE EACH 7 SEGMENT LED DISPLAY  
 NOTE 2: 7 SEGMENT LED DISPLAY DS3 IS NOT USED



0140M00407-A

# SERVICING

## S-10B COPELAND CORESENSE™

### DIAGNOSTICS - 3-WIRE MODULE

Applies to ASX /ASZ and DSX/DSZ units

**WARNING**

**HIGH VOLTAGE**  
Disconnect ALL power before servicing or installing this unit. Multiple power sources may be present. Failure to do so may cause property damage, personal injury or death.



The CoreSense™ module is self-contained with no required external sensors and works with any residential condensing unit that has a Copeland Scroll™ compressor inside.

Once attached, CoreSense provides around-the-clock monitoring for common electrical problems, compressor defects and broad system faults. If a glitch is detected, an LED indicator flashes the proper alert codes to help you quickly pinpoint the problem. See *Diagnostic Table: 3-Wire CoreSense™ Module* on following pages.)

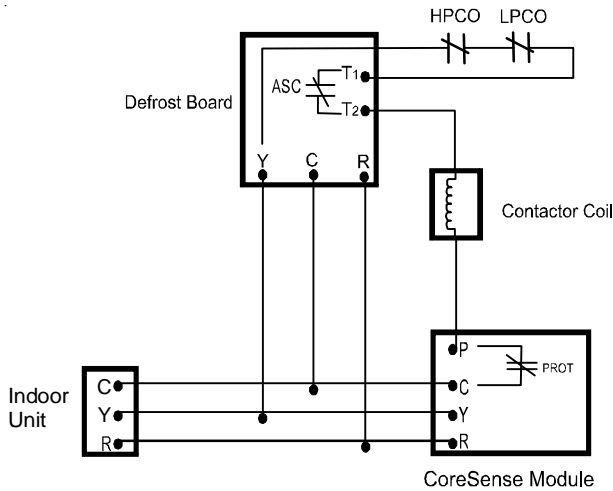

Schematic Abbreviation Descriptions

|      |                                 |     |  |
|------|---------------------------------|-----|--|
| HTCO | High Temperature Cut Out Switch | CC  | Compressor Contactor                             |
| HPCO | High Pressure Cut Out Switch    | ECB | Electronic Control Board (Defrost or Time Delay) |
| LPCO | Low Pressure Cut Out Switch     |     |  |

### Wiring Schematic - 3-Wire CoreSense™ Alert Module

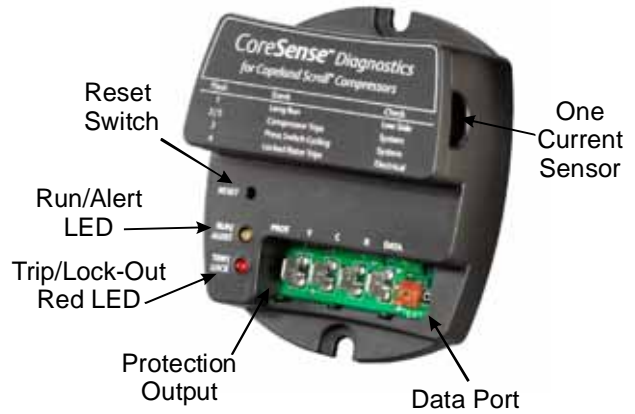

### DIAGNOSTICS - 2-WIRE MODULE

Applies to ASX130[18-60]CA, ASX140[18-36]1CA, ASX140421DA, and ASX140[48-60]1BA units

**WARNING**

**HIGH VOLTAGE**  
Disconnect ALL power before servicing or installing this unit. Multiple power sources may be present. Failure to do so may cause property damage, personal injury or death.



The CoreSense™ module is self-contained with no required external sensors and works with any residential condensing unit that has a Copeland Scroll™ compressor inside.

Once attached, CoreSense™ provides around-the-clock monitoring for common electrical problems, compressor defects and broad system faults. If a glitch is detected, an LED indicator flashes the proper alert codes to help you quickly pinpoint the problem. See *Diagnostic Table: 2-Wire Comfort Alert™ Module* on following pages.)

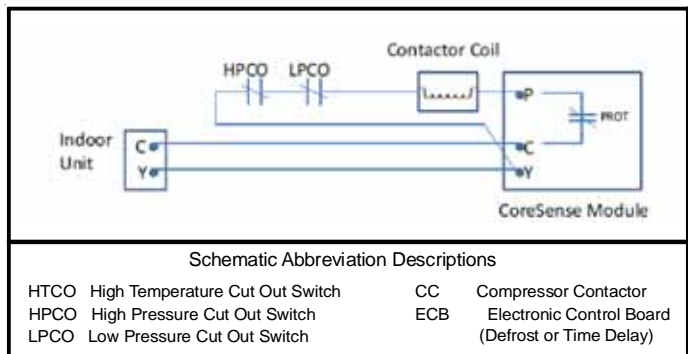

Schematic Abbreviation Descriptions

|      |                                 |     |  |
|------|---------------------------------|-----|--|
| HTCO | High Temperature Cut Out Switch | CC  | Compressor Contactor                             |
| HPCO | High Pressure Cut Out Switch    | ECB | Electronic Control Board (Defrost or Time Delay) |
| LPCO | Low Pressure Cut Out Switch     |     |  |

### Wiring Schematic - 2-Wire CoreSense™ Module

# SERVICING

## DIAGNOSTICS TABLE: CORESENSE™ MODULE

Flash code number corresponds to the number of LED flashes, followed by a pause and then repeated. TRIP and ALERT LEDs flashing at the same time mean control circuit voltage is too low for operation.

| Status                      | Description  | Troubleshooting Information   |
|-----------------------------|--|---|
| Solid Yellow "RUN"          | Module has power and operating normally  | Supply voltage is present at module terminals   |
| Solid Red "TRIP"            | Thermostat demand signal Y is present, but the compressor is not running   | <ol style="list-style-type: none"> <li>Compressor protector is open <ul style="list-style-type: none"> <li>Check for high head pressure</li> <li>Check compressor supply voltage</li> </ul> </li> <li>Outdoor unit power disconnect is open</li> <li>Compressor circuit breaker or fuse(s) is open</li> <li>Broken wire or connector is not making contact</li> <li>High pressure switch open if present in system</li> <li>Compressor contactor has failed open</li> </ol>   |
| <b>"ALERT" Flash Codes</b>  |  |   |
| Yellow "ALERT" Flash Code 1 | Long Run Time; Compressor is running extremely long run cycles indicative of low capacity due to a system low-side fault | <ol style="list-style-type: none"> <li>Low refrigerant charge</li> <li>Evaporator blower is not running <ul style="list-style-type: none"> <li>Check blower relay coil and contacts</li> <li>Check blower motor capacitor</li> <li>Check blower motor for failure or blockage</li> <li>Check evaporator blower wiring and connectors</li> <li>Check indoor blower control board</li> <li>Check thermostat wiring for open circuit</li> </ul> </li> <li>Evaporator coil is frozen <ul style="list-style-type: none"> <li>Check for low suction pressure</li> <li>Check for excessively low thermostat setting</li> <li>Check evaporator airflow (coil blockages or return air filter)</li> <li>Check ductwork or registers for blockage</li> </ul> </li> <li>Faulty metering device <ul style="list-style-type: none"> <li>Check TXV bulb installation (size, location and contact)</li> <li>Check if TXV/fixed orifice is stuck closed or defective</li> </ul> </li> <li>Liquid line restriction (filter drier blocked if present in system)</li> <li>Thermostat is malfunctioning <ul style="list-style-type: none"> <li>Check thermostat sub-base or wiring for short circuit</li> <li>Check thermostat installation (location, level)</li> </ul> </li> </ol> |
| Yellow "ALERT" Flash Code 2 | Compressor (Pressure) Trip; Discharge pressure out of limits or compressor overloaded                                    | <ol style="list-style-type: none"> <li>Condenser fan is not running <ul style="list-style-type: none"> <li>Check fan capacitor</li> <li>Check fan wiring and connectors</li> <li>Check fan motor for failure or blockage</li> </ul> </li> <li>High head pressure <ul style="list-style-type: none"> <li>Check high pressure switch if present in system</li> <li>Check if system is overcharged with refrigerant</li> <li>Check for non-condensable in system</li> </ul> </li> <li>Condenser coil poor air circulation (dirty, blocked, damaged)</li> </ol>   |
| Yellow "ALERT" Flash Code 3 | Short Cycling; Compressor is running only briefly  | <ol style="list-style-type: none"> <li>Thermostat demand signal is intermittent</li> <li>Time delay relay or control board defective</li> <li>Low or high pressure switch is cycling</li> </ol>   |

# SERVICING

## DIAGNOSTICS TABLE: CORESENSE™ MODULE (cont.)

Flash code number corresponds to the number of LED flashes, followed by a pause and then repeated.

TRIP and ALERT LEDs flashing at the same time mean control circuit voltage is too low for operation.

| Status                                   | Description  | Troubleshooting Information  |
|--|--|--|
| Yellow "ALERT"<br>Flash Code 4           | Locked Rotor   | <ol style="list-style-type: none"> <li>1. Run capacitor has failed</li> <li>2. Low line voltage (contact utility if voltage at disconnect is low) <ul style="list-style-type: none"> <li>• Check wiring connections</li> </ul> </li> <li>3. Excessive liquid refrigerant in compressor</li> <li>4. Compressor bearings are seized <ul style="list-style-type: none"> <li>• Measure compressor oil level</li> </ul> </li> </ol>   |
| Yellow "ALERT"<br>Flash Code 5           | Compressor (Moderate Run)<br>Trip  | <ol style="list-style-type: none"> <li>1. Evaporator blower is not running <ul style="list-style-type: none"> <li>• Check blower relay coil and contacts</li> <li>• Check blower motor capacitor</li> <li>• Check blower motor for failure or blockage</li> <li>• Check evaporator blower wiring and connectors</li> <li>• Check indoor blower control board</li> <li>• Check thermostat wiring for open circuit</li> </ul> </li> <li>2. Faulty metering device <ul style="list-style-type: none"> <li>• Check TXV bulb installation (size, location and contact)</li> <li>• Check if TXV/fixed orifice is stuck closed or defective</li> </ul> </li> <li>3. Condenser coil poor air circulation (dirty, blocked, damaged)</li> <li>4. Low refrigerant charge</li> </ol> |
| <b>"LOCK" Flash Codes</b>                |  |  |
| Red "LOCK"<br>Flash Code 2<br>Yellow Off | Compressor (Pressure) Trip;<br>Compressor is locked out<br>after 4 consecutive or 10 total<br>compressor (pressure) trip<br>events         | <ol style="list-style-type: none"> <li>1. Condenser fan is not running <ul style="list-style-type: none"> <li>• Check fan capacitor</li> <li>• Check fan wiring and connectors</li> <li>• Check fan motor for failure or blockage</li> </ul> </li> <li>2. High head pressure <ul style="list-style-type: none"> <li>• Check high pressure switch if present in system</li> <li>• Check if system is overcharged with refrigerant</li> <li>• Check for non-condensable in system</li> </ul> </li> <li>3. Condenser coil poor air circulation (dirty, blocked, damaged)</li> </ol>   |
| Red "LOCK"<br>Flash Code 3<br>Yellow Off | Short Cycling: Compressor is<br>locked out after 10 consecutive<br>short cycling events  | <ol style="list-style-type: none"> <li>1. Thermostat demand signal is intermittent</li> <li>2. Time delay relay or control board defective</li> <li>3. If high pressure switch present go to Flash Code 2 information</li> </ol>   |
| Red "LOCK"<br>Flash Code 4<br>Yellow Off | Locked Rotor; Compressor is<br>locked out after 10 consecutive<br>locked rotor events  | <ol style="list-style-type: none"> <li>1. Run capacitor has failed</li> <li>2. Low line voltage (contact utility if voltage at disconnect is low) <ul style="list-style-type: none"> <li>• Check wiring connections</li> </ul> </li> <li>3. Excessive liquid refrigerant in compressor</li> <li>4. Compressor bearings are seized <ul style="list-style-type: none"> <li>• Measure compressor oil level</li> </ul> </li> </ol>   |
| Red "LOCK"<br>Flash Code 5<br>Yellow Off | Compressor (Moderate Run)<br>Trip; Compressor is locked out<br>after 4 consecutive or 10 total<br>compressor (moderate run) trip<br>events | <ol style="list-style-type: none"> <li>1. Evaporator blower is not running <ul style="list-style-type: none"> <li>• Check blower relay coil and contacts</li> <li>• Check blower motor capacitor</li> <li>• Check blower motor for failure or blockage</li> <li>• Check evaporator blower wiring and connectors</li> <li>• Check indoor blower control board</li> <li>• Check thermostat wiring for open circuit</li> </ul> </li> <li>2. Faulty metering device <ul style="list-style-type: none"> <li>• Check TXV bulb installation (size, location and contact)</li> <li>• Check if TXV/fixed orifice is stuck closed or defective</li> </ul> </li> <li>3. Condenser coil poor air circulation (dirty, blocked, damaged)</li> <li>4. Low refrigerant charge</li> </ol> |

# SERVICING

Table 1 - Quick Reference Table

| Alert Code                 | Alert Condition   | Lock Level                     | Lock Indication             |
|----------------------------|---|--------------------------------|-----------------------------|
| Normal Run<br>Solid Yellow | Normal operation, no trip.  | N/A                            | N/A                         |
| Code1<br>Yellow Flash 1    | Long run time. Compressor is on running for more than 18 hours. (Code1 is disabled in Heat Pump mode.)                              | N/A                            | N/A                         |
| Code2<br>Yellow Flash 2    | Compressor (pressure) trip. Compressor runs for 12 sec to 15 min followed by a compressor trip condition lasting longer than 7 min. | 4x consecutive                 | Red: Flash 2<br>Yellow: Off |
| Code3<br>Yellow Flash 3    | Pressure switch cycling. Compressor runs for 12 sec to 15 min followed by a compressor trip lasting between 35 sec to 7 min.        | 4x consecutive<br>or 10x total | Red: Flash 3<br>Yellow: Off |
| Code4<br>Yellow Flash 4    | Locked rotor. Compressor trips within a compressor run time of 12 sec and does not start within 35 sec.                             | 10x consecutive                | Red: Flash 4<br>Yellow: Off |
| Code5<br>Yellow Flash 5    | Compressor (moderate run) trip. Compressor runs for 15 min to 18 hrs followed by a compressor trip lasting longer than 7 min.       | 4x consecutive<br>or 10x total | Red: Flash 5<br>Yellow: Off |
| Code9<br>Red Flash 9       | The current to the PROT terminal is greater than 2A   | Current >2A<br>for 40ms        | Red: Flash 9<br>Yellow: Off |
| Trip<br>Solid Red          | Demand is present, but compressor is not running  | N/A                            | N/A                         |

# SERVICING

## S-11 CHECKING LOSS OF CHARGE PROTECTOR

*(Heat Pump Models)*

The loss of charge protector senses the pressure in the liquid line and will open its contacts on a drop in pressure. The low pressure control will automatically reset itself with a rise in pressure.

The low pressure control is designed to cut-out (open) at approximately 21 PSIG. It will automatically cut-in (close) at approximately 50 PSIG. Test for continuity using a VOM and if not as above, replace the control.

## S-12 CHECKING HIGH PRESSURE CONTROL

**⚠ WARNING**

**HIGH VOLTAGE!**  
Disconnect ALL power before servicing or installing. Multiple power sources may be present. Failure to do so may cause property damage, personal injury or death.



The high pressure control capillary senses the pressure in the compressor discharge line. If abnormally high condensing pressures develop, the contacts of the control open, breaking the control circuit before the compressor motor overloads. This control is automatically reset.

1. Using an ohmmeter, check across terminals of high pressure control, with wire removed. If not continuous, the contacts are open.
2. Attach a gauge to the dill valve port on the base valve.

With power ON:

**⚠ WARNING**

**Line Voltage now present.**

3. Start the system and place a piece of cardboard in front of the condenser coil, raising the condensing pressure.
4. Check pressure at which the high pressure control cuts-out. If it cuts-out at 610 PSIG  $\pm$  10 PSIG, it is operating normally (See causes for high head pressure in Service Problem Analysis Guide). If it cuts out below this pressure range, replace the control.

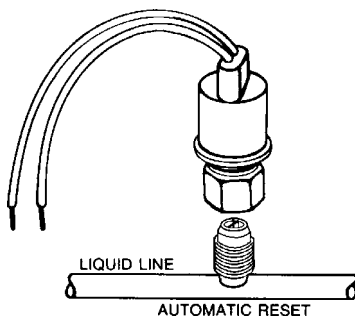

## S-13 CHECKING LOW PRESSURE CONTROL

The low pressure control senses the pressure in the suction line and will open its contacts on a drop in pressure. The low pressure control will automatically reset itself with a rise in pressure.

The low pressure control is designed to cut-out (open) at approximately 21 PSIG for heat pumps and 55 PSIG for air conditioners. It will automatically cut-in (close) at approximately 50 PSIG for heat pumps and 95 PSIG for air conditioners.

Test for continuity using a VOM and if not as above, replace the control.

## S-15 CHECKING CAPACITOR CAPACITOR, RUN

A run capacitor is wired across the auxiliary and main windings of a single phase permanent split capacitor motor. The capacitor's primary function is to reduce the line current while greatly improving the torque characteristics of a motor. This is accomplished by using the 90° phase relationship between the capacitor current and voltage in conjunction with the motor windings, so that the motor will give two phase operation when connected to a single phase circuit. The capacitor also reduces the line current to the motor by improving the power factor.

The line side of this capacitor is marked with "COM" and is wired to the line side of the circuit.

## CAPACITOR, START

### SCROLL COMPRESSOR MODELS

In most cases hard start components are not required on Scroll compressor equipped units due to a non-replaceable check valve located in the discharge line of the compressor. However, in installations that encounter low lock rotor voltage, a hard start kit can improve starting characteristics and reduce light dimming within the home. Only hard start kits approved by Amana® brand or Copeland should be used. "Kick Start" and/or "Super Boost" kits are not approved start assist devices.

The discharge check valve closes off high side pressure to the compressor after shut down allowing equalization through the scroll flanks. Equalization requires only about 1/2 second.

To prevent the compressor from short cycling, a Time Delay Relay (Cycle Protector) has been added to the low voltage circuit.

# SERVICING

## RELAY, START

A potential or voltage type relay is used to take the start capacitor out of the circuit once the motor comes up to speed. This type of relay is position sensitive. The normally closed contacts are wired in series with the start capacitor and the relay holding coil is wired parallel with the start winding. As the motor starts and comes up to speed, the increase in voltage across the start winding will energize the start relay holding coil and open the contacts to the start capacitor.

Two quick ways to test a capacitor are a resistance and a capacitance check.

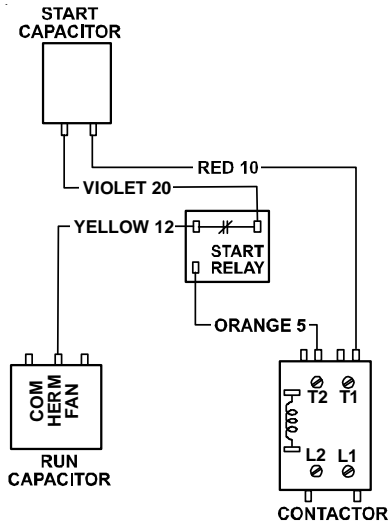

## HARD START KIT WIRING

### S-15A RESISTANCE CHECK

**⚠ WARNING**

**HIGH VOLTAGE!**  
Disconnect ALL power before servicing or installing. Multiple power sources may be present. Failure to do so may cause property damage, personal injury or death.

1. Discharge capacitor and remove wire leads.

**⚠ WARNING**

Discharge capacitor through a 20 to 30 OHM resistor before handling.

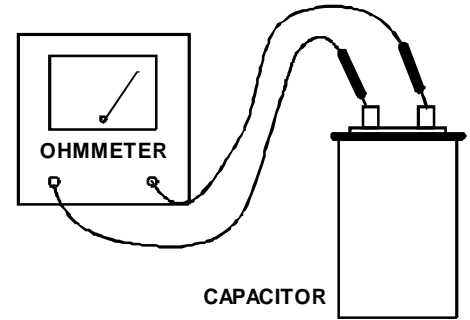

### TESTING CAPACITOR RESISTANCE

2. Set an ohmmeter on its highest ohm scale and connect the leads to the capacitor -
  - A. Good Condition - indicator swings to zero and slowly returns to infinity. (Start capacitor with bleed resistor will not return to infinity. It will still read the resistance of the resistor).
  - B. Shorted - indicator swings to zero and stops there - replace.
  - C. Open - no reading - replace. (Start capacitor would read resistor resistance.)

### S-15B CAPACITANCE CHECK

Using a hookup as shown below, take the amperage and voltage readings and use them in the formula:

$$\text{Capacitance (MFD)} = \frac{2650 \times \text{Amperage}}{\text{Voltage}}$$

**⚠ WARNING**

Discharge capacitor through a 20 to 30 OHM resistor before handling.

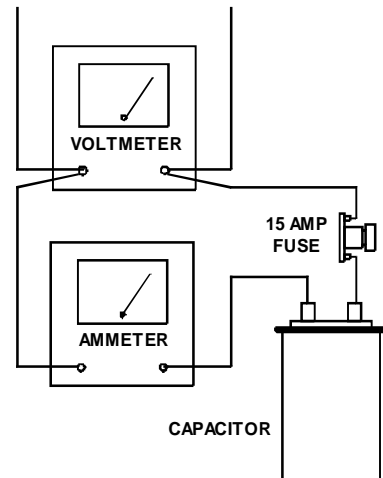

### TESTING CAPACITANCE

# SERVICING

## S-16A CHECKING FAN AND BLOWER MOTOR WINDINGS (PSC MOTORS)

The auto reset fan motor overload is designed to protect the motor against high temperature and high amperage conditions by breaking the common circuit within the motor, similar to the compressor internal overload. However, heat generated within the motor is faster to dissipate than the compressor, allow at least 45 minutes for the overload to reset, then retest.



**WARNING**  
**HIGH VOLTAGE!**  
 Disconnect ALL power before servicing or installing. Multiple power sources may be present. Failure to do so may cause property damage, personal injury or death.

1. Remove the motor leads from its respective connection points and capacitor (if applicable).
2. Check the continuity between each of the motor leads.
3. Touch one probe of the ohmmeter to the motor frame (ground) and the other probe in turn to each lead.

If the windings do not test continuous or a reading is obtained from lead to ground, replace the motor.

## S-16B CHECKING FAN AND BLOWER MOTOR (ECM MOTORS)

An ECM is an *Electronically Commutated Motor* which offers many significant advantages over PSC motors. The ECM has near zero rotor loss, synchronous machine operation, variable speed, low noise, and programmable air flow. Because of the sophisticated electronics within the ECM motor, some technicians are intimidated by the ECM motor; however, these fears are unfounded. GE offers two ECM motor testers, and with a VOM meter, one can easily perform basic troubleshooting on ECM motors. An ECM motor requires power (line voltage) and a signal (24 volts) to operate. The ECM motor stator contains permanent magnet. As a result, the shaft feels "rough" when turned by hand. This is a characteristic of the motor, not an indication of defective bearings.



**WARNING**  
 Line Voltage now present.

1. Disconnect the 5-pin connector from the motor.
2. Using a volt meter, check for line voltage at terminals #4 & #5 at the power connector. If no voltage is present:
3. Check the unit for incoming power See section S-1.
4. Check the control board, See section S-40.
5. If line voltage is present, reinsert the 5-pin connector and remove the 16-pin connector.

6. Check for signal (24 volts) at the transformer.
7. Check for signal (24 volts) from the thermostat to the "G" terminal at the 16-pin connector.
8. Using an ohmmeter, check for continuity from the #1 & #3 (common pins) to the transformer neutral or "C" thermostat terminal. If you do not have continuity, the motor may function erratically. Trace the common circuits, locate and repair the open neutral.
9. Set the thermostat to "Fan-On". Using a voltmeter, check for 24 volts between pin # 15 (G) and common.
10. Disconnect power to compressor. Set thermostat to call for cooling. Using a voltmeter, check for 24 volts at pin # 6 and/or #14.
11. Set the thermostat to a call for heating. Using a voltmeter, check for 24 volts at pin #2 and/or #11.

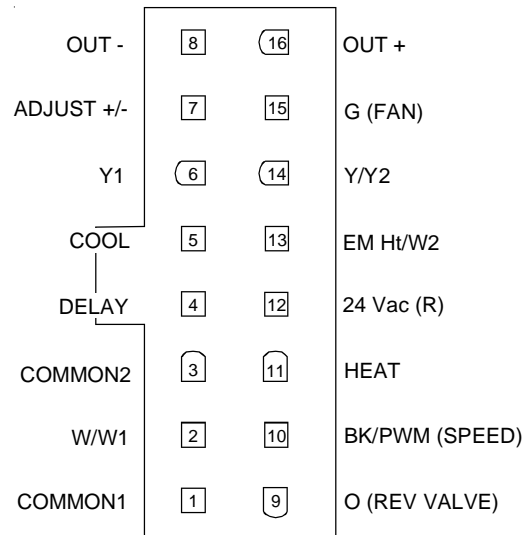
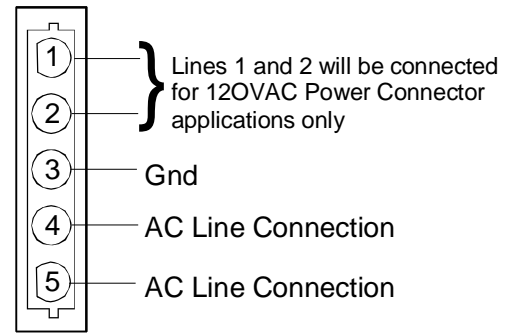

16-PIN ECM HARNESS CONNECTOR

If you do not read voltage and continuity as described, the problem is in the control or interface board, but not the motor. If you register voltage as described, the ECM power head is defective and must be replaced.



# SERVICING

| Troubleshooting Chart for GE/Regal-Beloit ECM Variable Speed Air Circulator Blower Motors |  |   |  |
|---|--|---|--|
| Symptom   | Fault Description(s)   | Possible Causes   | Corrective Action  |
| - Motor rocks slightly when starting.   | - This is normal start-up for variable speed motor.          | ----  | ----   |
| - Motor won't start.  | - No movement.   | - Manual disconnect switch off or door switch open.<br>- Blown fuse or circuit breaker.<br>- 24 Vac wires miswired.<br>- Unseated pins in wiring harness connectors.<br>- Bad motor/control module.<br>- Moisture present in motor or control module. | - Check 230 Vac power at motor.<br>- Check low voltage (24 Vac R to C) at motor.<br>- Check low voltage connections (G, Y, W, R, C) at motor.<br>- Check for unseated pins in connectors on motor harness.<br>- Test with a temporary jumper between R - G.          |
| - Motor starts, but runs erratically.   | - Motor rocks, but won't start.                              | - Loose motor mount.<br>- Blower wheel not tight on motor shaft.<br>- Bad motor/control module.   | - Turn power OFF prior to repair.<br>Wait 5 minutes after disconnecting power before opening motor.<br>- Handle electronic motor/control with care.  |
| - Motor oscillates up & down while being tested off of blower.                            | - It is normal for motor to oscillate with no load on shaft. | ----  | ----   |
| - Motor starts, but runs erratically.   | - Varies up and down or intermittent.                        | - Variation in 230 Vac to motor.<br>- Unseated pins in wiring harness connectors.<br>- Erratic CFM command from "BK" terminal.<br>- Improper thermostat connection or setting.<br>- Moisture present in motor/control module.                         | - Check line voltage for variation or "sag".<br>- Check low voltage connections (G, Y, W, R, C) at motor, unseated pins in motor harness connectors.<br>- Check-out system controls - Thermostat.<br>- Perform Moisture Check.*<br>- Turn power OFF prior to repair. |
|   | - "Hunts" or "puffs" at high CFM (speed).                    | - Incorrect or dirty filter(s).<br>- Incorrect supply or return ductwork.<br>- Incorrect blower speed setting.  | - Does removing panel or filter reduce "puffing"?<br>- Check/replace filter.<br>- Check/correct duct restrictions.<br>- Adjust to correct blower speed setting.<br>- Turn power OFF prior to repair.   |

### \*Moisture Check

- Connectors are oriented "down" (or as recommended by equipment manufacturer).
- Is condensate drain plugged?
- Check for uncharged condensation.

**Note:** You must use the correct replacement control/motor module since they are factory programmed for specific operating modes. Even though they look alike, different modules may have completely different functionality. The ECM variable speed motors are c

**Important Note:** Using the wrong motor/control module voids all product warranties and may produce unexpected results.

**CHART CONTINUED ON NEXT PAGE**

## CHART CONTINUED FROM PREVIOUS PAGE.

### Troubleshooting Chart for GE/Regal-Beloit ECM Variable Speed Air Circulator Blower Motors

| Symptom                                   | Fault Description(s)   | Possible Causes   | Corrective Action  | Cautions and Notes   |
|---|--|---|--|--|
| - Motor starts, but runs erratically.     | - Stays at low CFM despite system call for cool or heat CFM.         | - 24 Vac wires miswired or loose.<br>- "R" missing/not connected at motor.<br>- Fan in delay mode.  | - Check low voltage (Thermostat) wires and connections.<br>- Verify fan is not in delay mode - wait until delay complete.<br>- Perform motor/control replacement check, ECM motors only. | - Turn power OFF prior to repair. Wait 5 minutes after disconnecting power before opening motor.<br>- Handle electronic motor/control with care. |
| - Motor starts, but runs erratically.     | - Stays at high CFM.   | - "R" missing/not connected at motor.<br>- Fan in delay mode.   | - Is fan in delay mode? - wait until delay time complete.<br>- Perform motor/control replacement check, ECM motors only.   | - Turn power OFF prior to repair. Wait 5 minutes after disconnecting power before opening motor.<br>- Handle electronic motor/control with care. |
| - Blower won't shut off.                  | - Blower won't shut off.   | - Current leakage from controls into G, Y, or W.  | - Check for Triac switched stat or solid state relay.  | - Turn power OFF prior to repair.  |
| - Air noise.                              | - Air noise.   | - High static creating high blower speed.<br>- Incorrect supply or return ductwork.<br>- Incorrect or dirty filter(s).<br>- Incorrect blower speed setting. | - Check/replace filter.<br>- Check/correct duct restrictions.<br>- Adjust to correct blower speed setting.   | - Turn power OFF prior to repair.  |
| - Excessive noise.                        | - Noisy blower or cabinet.   | - Loose blower housing, panels, etc.<br>- High static creating high blower speed.<br>- Air leaks in ductwork, cabinets, or panels.                          | - Check for loose blower housing, panels, etc.<br>- Check for air whistling thru seams in ducts, cabinets or panels.<br>- Check for cabinet/duct deformation.                            | - Turn power OFF prior to repair.  |
| - "Hunts" or "puffs" at high CFM (speed). | - "Hunts" or "puffs" at high CFM (speed).                            | - High static creating high blower speed.<br>- Incorrect or dirty filter(s).<br>- Incorrect supply or return ductwork.<br>- Incorrect blower speed setting. | - Does removing panel or filter reduce "puffing"?<br>- Check/replace filter.<br>- Check/correct duct restrictions.<br>- Adjust to correct blower speed setting.                          | - Turn power OFF prior to repair.  |
| - Evidence of Moisture.                   | - Motor failure or malfunction has occurred and moisture is present. | - Moisture in motor/control module.   | - Replace motor and perform Moisture Check.*   | - Turn power OFF prior to repair. Wait 5 minutes after disconnecting power before opening motor.<br>- Handle electronic motor/control with care. |

#### \*Moisture Check

- Connectors are oriented "down" (or as recommended by equipment manufacturer).
- Is condensate drain plugged?
- Check for uncharged condensation.

**Note:** You must use the correct replacement control/motor module since they are factory programmed for specific operating modes. Even though they look alike, different modules may have completely different functionality. The ECM variable speed motors are c

**Important Note:** Using the wrong motor/control module voids all product warranties and may produce unexpected results.

# SERVICING

## S-16C CHECKING ECM MOTOR WINDINGS



**WARNING**  
**HIGH VOLTAGE!**  
 Disconnect ALL power before servicing or installing. Multiple power sources may be present. Failure to do so may cause property damage, personal injury or death.

1. Disconnect the 5-pin and the 16-pin connectors from the ECM power head.
2. Remove the 2 screws securing the ECM power head and separate it from the motor.
3. Disconnect the 3-pin motor connector from the power head and lay it aside.
4. Using an ohmmeter, check the motor windings for continuity to ground (pins to motor shell). If the ohmmeter indicates continuity to ground, the motor is defective and must be replaced.
5. Using an ohmmeter, check the windings for continuity (pin to pin). If no continuity is indicated, the thermal limit (over load) device may be open. Allow motor to cool and retest.

retest.

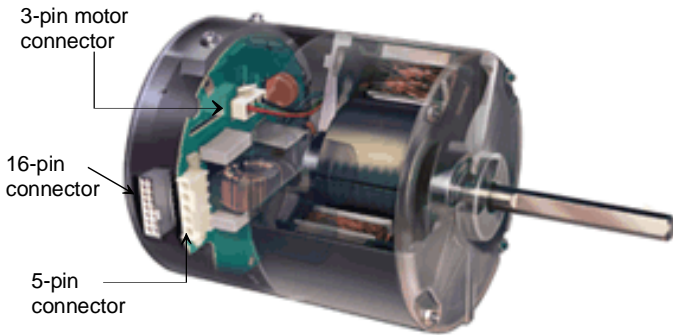

## S-16D ECM CFM ADJUSTMENTS MBE / AEPF

### MBE MOTOR

This section references the operation characteristics of the MBE/AEPF models motor only. The ECM control board is factory set with the dipswitch #4 in the "ON" position and all other dipswitches are factory set in the "OFF" position. When MBE/AEPF are used with 2-stage cooling units, dipswitch #4 should be in the "OFF" position.

**For most applications, the settings are to be changed according to the electric heat size and the outdoor unit selection.**

The MBE/AEPF products use a General Electric ECM™ motor. This motor provides many features not available on the traditional PSC motor. These features include:

- Improved Efficiency
- Constant CFM
- Soft Start and Stop
- Improved Humidity Control

### MOTOR SPEED ADJUSTMENT

Each ECM™ blower motor has been preprogrammed for operation at 4 distinct airflow levels when operating in Cooling/Heat Pump mode or Electric Heat mode. These 4 distinct levels may also be adjusted slightly lower or higher if desired. The adjustment between levels and the trim adjustments are made by changing the dipswitch(s) either to an "OFF" or "ON" position.

### DIPSWITCH FUNCTIONS

The MBE / AEPF air handler motors have an electronic control that contains an eight (8) position dip switch. The function of these dipswitches are shown in **Table 1**.

| Dipswitch Number | Function                |
|------------------|-------------------------|
| 1                | Electric Heat           |
| 2                |                         |
| 3                | N/A                     |
| 4                | Indoor Thermostat       |
| 5                | Cooling & Heat Pump CFM |
| 6                |                         |
| 7                | CFM Trim Adjust         |
| 8                |                         |

**Table 1**

### CFM DELIVERY

Tables 2, 3, 5 and 6 show the CFM output for dipswitch combinations 1-2, and 5-6.

### Electric Heat Operation

| Model   | Switch 1 | Switch 2 | CFM   |
|---------|----------|----------|-------|
| MBE1200 | OFF      | OFF      | 1,200 |
|         | ON       | OFF      | 1,000 |
|         | OFF      | ON       | 800   |
|         | ON       | ON       | 600   |
| MBE1600 | OFF      | OFF      | 1,600 |
|         | ON       | OFF      | 1,400 |
|         | OFF      | ON       | 1,200 |
|         | ON       | ON       | 1,000 |
| MBE2000 | OFF      | OFF      | 2,000 |
|         | ON       | OFF      | 1,800 |
|         | OFF      | ON       | 1,600 |
|         | ON       | ON       | 1,200 |

**Table 2**

# SERVICING

**Cooling/Heat Pump Operation**

| Model   | Switch 5 | Switch 6 | CFM   |
|---------|----------|----------|-------|
| MBE1200 | OFF      | OFF      | 1,200 |
|         | ON       | OFF      | 1,000 |
|         | OFF      | ON       | 800   |
|         | ON       | ON       | 600   |
| MBE1600 | OFF      | OFF      | 1,600 |
|         | ON       | OFF      | 1,400 |
|         | OFF      | ON       | 1,200 |
|         | ON       | ON       | 1,000 |
| MBE2000 | OFF      | OFF      | 2,000 |
|         | ON       | OFF      | 1,800 |
|         | OFF      | ON       | 1,600 |
|         | ON       | ON       | 1,200 |

**Table 3**

**THERMOSTAT “FAN ONLY” MODE**

During Fan Only Operations, the CFM output is 30% of the cooling setting.



**WARNING**

Hermetic compressor electrical terminal venting can be dangerous. When insulating material which supports a hermetic compressor or electrical terminal suddenly disintegrates due to physical abuse or as a result of an electrical short between the terminal and the compressor housing, the terminal may be expelled, venting the vapor and liquid contents of the compressor housing and system.

If the compressor terminal PROTECTIVE COVER and gasket (if required) are not properly in place and secured, there is a remote possibility if a terminal vents, that the vaporous and liquid discharge can be ignited, spouting flames several feet, causing potentially severe or fatal injury to anyone in its path.

This discharge can be ignited external to the compressor if the terminal cover is not properly in place and if the discharge impinges on a sufficient heat source.

Ignition of the discharge can also occur at the venting terminal or inside the compressor, if there is sufficient contaminant air present in the system and an electrical arc occurs as the terminal vents.

Ignition cannot occur at the venting terminal without the presence of contaminant air, and cannot occur externally from the venting terminal without the presence of an external ignition source.

Therefore, proper evacuation of a hermetic system is essential at the time of manufacture and during servicing.

To reduce the possibility of external ignition, all open flame, electrical power, and other heat sources should be extinguished or turned off prior to servicing a system.

If the following test indicates shorted, grounded or open windings, see procedures S-19 for the next steps to be taken.

# SERVICING

## S-16E BLOWER PERFORMANCE DATA

| SPEED  | STATIC | MBR800**-*<br>SCFM | MBR1200**-*<br>SCFM | MBR1600**-*<br>SCFM | MBR2000**-*<br>SCFM |
|--------|--------|--------------------|---------------------|---------------------|---------------------|
| HIGH   | 0.1    | 1,240              | 1,500               | 1,800               | 2,160               |
|        | 0.2    | 1,170              | 1,460               | 1,740               | 2,080               |
|        | 0.3    | 1,120              | 1,360               | 1,680               | 1,990               |
|        | 0.4    | 1,060              | 1,280               | 1,610               | 1,890               |
|        | 0.5    | 980                | 1,200               | 1,520               | 1,790               |
|        | 0.6    | 900                | 1,110               | 1,430               | 1,690               |
| MEDIUM | 0.1    | 900                | 1,380               | 1,540               | 1,730               |
|        | 0.2    | 850                | 1,320               | 1,490               | 1,670               |
|        | 0.3    | 790                | 1,270               | 1,450               | 1,590               |
|        | 0.4    | 740                | 1,200               | 1,400               | 1,520               |
|        | 0.5    | 680                | 1,140               | 13,560              | 1,420               |
|        | 0.6    | 605                | 1,040               | 1,280               | 1,320               |
| LOW    | 0.1    | 650                | 1,170               | 1,130               | 1,520               |
|        | 0.2    | 590                | 1,130               | 1,100               | 1,450               |
|        | 0.3    | 540                | 1,080               | 1,070               | 1,360               |
|        | 0.4    | 500                | 1,020               | 1,030               | 1,290               |
|        | 0.5    | 430                | 950                 | 990                 | 1,200               |
|        | 0.6    | 330                | 830                 | 930                 | 1,090               |

**NOTE:** External static is for blower @ 230 Volts. It does not include Coil, Air Filter or Electric Heaters.

### S-16F CHECKING HIGH EFFICIENCY MOTORS

The motor is a one piece, fully encapsulated, 3 phase brushless DC (single phase AC input) motor with ball bearing construction.

1. Using a voltmeter, check for 230 volts to the motor connections L and N. If 230 volts is present, proceed to step 2. If 230 volts is not present, check the line voltage circuit to the motor.
2. Using a voltmeter, check for 24 volts from terminal C to either terminal 1, 2, 3, 4, or 5, depending on which tap is being used, at the motor. If voltage present, proceed to step 3. If no voltage, check 24 volt circuit to motor.
3. If voltage was present in steps 1 and 2, the motor has failed and will need to be replaced.

**Note:** When replacing motor, ensure the belly band is between the vents on the motor and the wiring has the proper drip loop to prevent condensate from entering the motor.

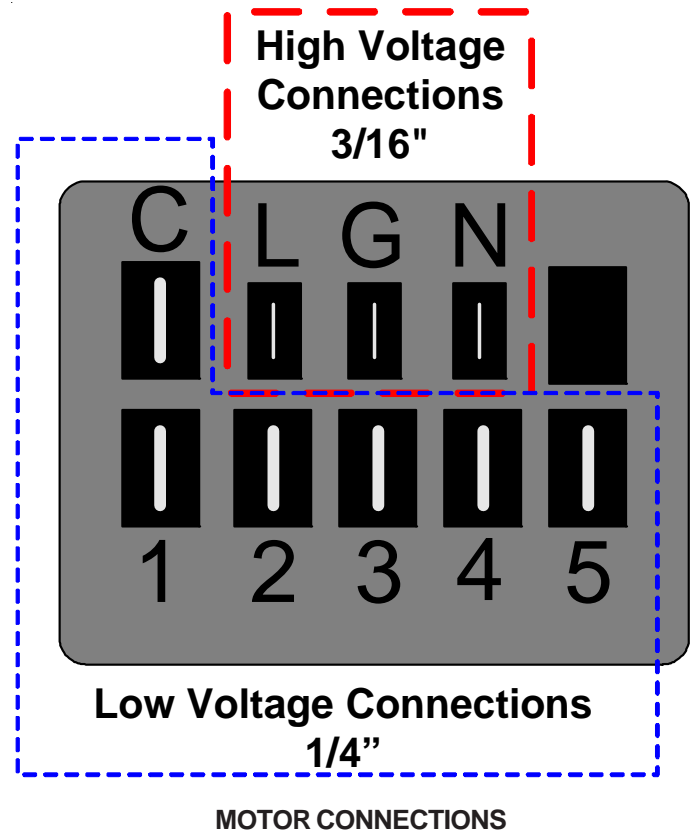

# SERVICING

## S-16G CHECKING EMERSON ULTRATECH™ ECM MOTORS

### DESCRIPTION

The AVPTC and MBVC models utilize an Emerson, 4-wire variable speed ECM blower motor. The ECM blower motor provides constant CFM.

The motor is a serially communicating variable speed motor. Only four wires are required to control the motor: +Vdc, Common, Receive, and Transmit.

The +Vdc and Common wires provide power to the motor's low voltage control circuits. Typical supply voltage is 9-15 volts DC.

### GENERAL CHECKS/CONSIDERATIONS

1. Check power supply to the air handler or modular blower. Ensure power supply is within the range specified on rating plate. See section S-1.
2. Check motor power harness. Ensure wires are continuous and make good contact when seated in the connectors. Repair or replace as needed.
3. Check motor control harness. Ensure wires are continuous and make good contact when seated in the connectors. Repair or replace as needed.
4. Check thermostat and thermostat wiring. Ensure thermostat is providing proper cooling/heating/continuous fan demands. Repair or replace as needed.
5. Check blower wheel. Confirm wheel is properly seated on motor shaft. Set screw must be on shaft flat and torqued to 165 in-lbs minimum. Confirm wheel has no broken or loose blades. Repair or replace as needed.
6. Ensure motor and wheel turn freely. Check for interference between wheel and housing or wheel and motor. Repair or replace as needed.
7. Check housing for cracks and/or corrosion. Repair or replace as needed.
8. Check motor mounting bracket. Ensure mounting bracket is tightly secured to the housing. Ensure bracket is not cracked or broken.

### Emerson UltraCheck-EZ™ Diagnostic Tool

The Emerson UltraCheck-EZ™ diagnostic tool may be used to diagnose the ECM motor.



**WARNING**

**HIGH VOLTAGE!**  
 Disconnect ALL power before servicing or installing. Multiple power sources may be present. Failure to do so may cause property damage, personal injury or death.



To use the diagnostic tool, perform the following steps:

1. Disconnect power to the air handler.
2. Disconnect the 4-circuit control harness from the motor.
3. Plug the 4-circuit connector from the diagnostic tool into the motor control connector.
4. Connect one alligator clip from the diagnostic tool to a ground source.
5. Connect the other alligator clip to a 24VAC source.

**NOTE:** The alligator clips are NOT polarized.

**NOTE:** The UltraCheck-EZ™ diagnostic tool is equipped with a nonreplaceable fuse. Connecting the tool to a source other than 24VAC could damage the tool and cause the fuse to open. Doing so will render the diagnostic tool inoperable.

6. Turn on power to air handler or modular blower.



**WARNING**

**Line Voltage now present.**

7. Depress the orange power button on the diagnostic tool to send a run signal to the motor. Allow up to 5 seconds for the motor to start.

**NOTE:** If the orange power button does not illuminate when depressed, the tool either has an open fuse or is not properly connected to a 24VAC source.

8. The green LED on the diagnostic tool will blink indicating communications between the tool and motor. See table below for indications of tool indicators and motor actions. Replace or repair as needed.

| Power Button | Green LED | Motor Action | Indication(s)   |
|--------------|-----------|--------------|---|
| OFF          | OFF       | Not Rotating | Confirm 24VAC to UltraCheck-EZ™ tool. If 24VAC is confirmed, diagnostic tool is inoperable. |
| ON           | Blinking  | Rotating     | Motor and control/end bell are functioning properly.  |
| ON           | OFF       | Rotating     | Replace motor control/end bell.   |
| ON           | Blinking  | Not Rotating | Check motor (see <i>Motor Checks</i> below).  |
| ON           | OFF       | Not Rotating | Replace motor control/end bell; verify motor (see <i>Motor Checks</i> below).               |

9. Depress the orange power button to turn off motor.
10. Disconnect power. Disconnect diagnostic tool.

# SERVICING

11. Reconnect the 4-wire harness from control board to motor.

## Electrical Checks - High Voltage Power Circuits



**WARNING**  
**HIGH VOLTAGE!**  
 Disconnect ALL power before servicing or installing. Multiple power sources may be present. Failure to do so may cause property damage, personal injury or death.



1. Disconnect power to air handler or modular blower.
2. Disconnect the 5-circuit power connector to the ECM motor.
3. Turn on power to air handler or modular.



**WARNING**  
**Line Voltage now present.**

4. Measure voltage between pins 4 and 5 on the 5-circuit connector. Measured voltage should be the same as the supply voltage to the air handler or modular.

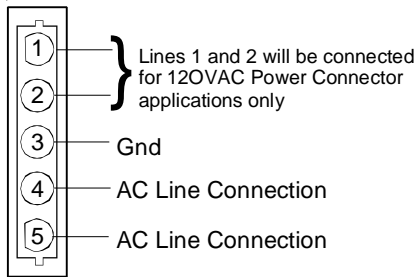

5. Measure voltage between pins 4 and 3. Voltage should be approximately half of the voltage measured in step 4.
6. Measure voltage between pins 5 and 3. Voltage should be approximately half of the voltage measured in step 4.
7. If no voltage is present, check supply voltage to air handler or modular blower. See section S-1.
8. Disconnect power to air handler or modular blower. Reconnect the 5-circuit power harness disconnected in step 2.

## Electrical Checks - Low Voltage Control Circuits

1. Turn on power to air handler or modular.



**WARNING**  
**Line Voltage now present.**

2. Check voltage between pins 1 and 4 on the 4-wire motor control harness between the motor and control board. Voltage should be between 9 and 15 VDC.
3. If no voltage is present, check control board. See section S-40A.

## Motor Control/End Bell Checks



**WARNING**  
**HIGH VOLTAGE!**  
 Disconnect ALL power before servicing or installing. Multiple power sources may be present. Failure to do so may cause property damage, personal injury or death.



1. Disconnect power to air handler or modular blower.
- NOTE:** Motor contains capacitors that can hold a charge for several minutes after disconnecting power. Wait 5 minutes after removing power to allow capacitors to discharge.
2. Disconnect the motor control harness and motor power harness.
  3. Remove the blower assembly from the air handler or modular blower.
  4. Remove the (3) screws securing the control/end bell to the motor. Separate the control/end bell. Disconnect the 3-circuit harness from the control/end bell to remove the control/end bell from the motor.
  5. Inspect the NTC thermistor inside the control/end bell (see figure below). Replace control/end bell if thermistor is cracked or broken.

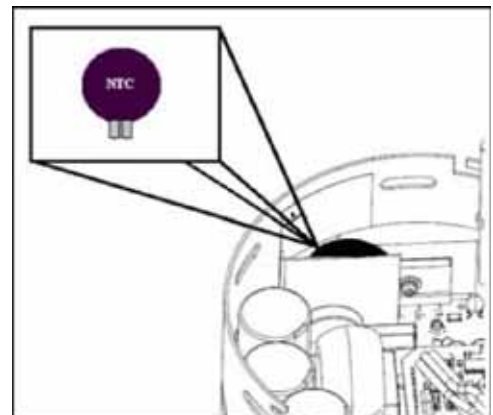

6. Inspect the large capacitors inside the control/end bell (see figure below). Replace the control/end bell if any of the capacitors are bulging or swollen.

# SERVICING

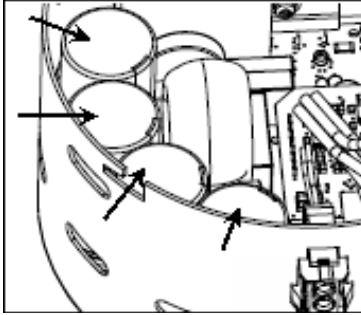

7. Locate the 3-circuit connector in the control/end bell. Using an ohmmeter, check the resistance between each terminal in the connector. If the resistance is 100kΩ or greater, the control/end bell is functioning properly. Replace the control/end bell if the resistance is lower than 100kΩ.
8. Reassemble motor and control/end bell in reverse of disassembly. Replace blower assembly into air handler or modular blower.

## Motor Checks

**⚠ WARNING**  
**HIGH VOLTAGE!**  
 Disconnect ALL power before servicing or installing. Multiple power sources may be present. Failure to do so may cause property damage, personal injury or death.

1. Disconnect power to air handler or modular blower.
- NOTE:** Motor contains capacitors that can hold a charge for several minutes after disconnecting power. Wait 5 minutes after removing power to allow capacitors to discharge.
2. Disassemble motor as described in steps 2 through 4 above.
  3. Locate the 3-circuit harness from the motor. Using an ohmmeter, measure the resistance between each motor phase winding. The resistance levels should be equal. Replace the motor if the resistance levels are unequal, open circuited or short circuited.
  4. Measure the resistance between each motor phase winding and the motor shell. Replace the motor if any phase winding is short circuited to the motor shell.
  5. Reassemble motor and control/end bell in reverse of disassembly. Replace blower assembly into air handler or modular blower.

## S-16H ECM CFM ADJUSTMENTS AVPTC/MBVC

This section references the operation characteristics of the MBVC models. The MBVC models utilize an integrated air handler control. The air handler control provides ECM blower motor control and includes all dipswitches necessary to set up the cooling, heat pump and electric airflow characteristics.

The control has three banks of dipswitches: a bank for cooling airflow and trim adjustment, a bank for selecting one of (4) enhancement profiles and enabling dehumidification, and a bank for selecting the installed electric heater kit size. Adjustments are made by selecting the appropriate ON/OFF combinations of the dipswitches. The dipswitches along with their functions are shown in the figures below.

*Cooling Airflow Dipswitches* - Used to set the desired cooling airflow

| Tap A   | Tap B                      | Tap C                                 | Tap D*                     |
|---|----------------------------|---------------------------------------|----------------------------|
| OFF ON  | OFF ON                     | OFF ON                                | OFF ON                     |
| 1 <input checked="" type="checkbox"/>                   | 1 <input type="checkbox"/> | 1 <input checked="" type="checkbox"/> | 1 <input type="checkbox"/> |
| 2 <input checked="" type="checkbox"/>                   | 2 <input type="checkbox"/> | 2 <input checked="" type="checkbox"/> | 2 <input type="checkbox"/> |
| Cooling Airflow Speed Tap (* indicates factory setting) |                            |                                       |                            |

*Airflow Adjust Dipswitches* - Used to adjust the airflow +/-10%

| Normal*   | +10%                       | -10%                                  | Normal                     |
|---|----------------------------|---------------------------------------|----------------------------|
| OFF ON  | OFF ON                     | OFF ON                                | OFF ON                     |
| 3 <input checked="" type="checkbox"/>             | 3 <input type="checkbox"/> | 3 <input checked="" type="checkbox"/> | 3 <input type="checkbox"/> |
| 4 <input checked="" type="checkbox"/>             | 4 <input type="checkbox"/> | 4 <input checked="" type="checkbox"/> | 4 <input type="checkbox"/> |
| Airflow Adjust Taps (* indicates factory setting) |                            |                                       |                            |

*Ramping Profile Dipswitches* - Used to select a comfort profile for the cooling mode.

| Tap A*   | Tap B                      | Tap C                                 | Tap D                      |
|--|----------------------------|---------------------------------------|----------------------------|
| OFF ON   | OFF ON                     | OFF ON                                | OFF ON                     |
| 5 <input checked="" type="checkbox"/>                          | 5 <input type="checkbox"/> | 5 <input checked="" type="checkbox"/> | 5 <input type="checkbox"/> |
| 6 <input checked="" type="checkbox"/>                          | 6 <input type="checkbox"/> | 6 <input checked="" type="checkbox"/> | 6 <input type="checkbox"/> |
| Cooling Airflow Ramping Profiles (* indicates factory setting) |                            |                                       |                            |



# SERVICING

**Dehumidification Disable/Enable Dipswitch** - Reduces cooling airflow by ~ 15% when enabled AND when used with a humidistat (such as DEHUM1). Airflow is reduced when a call for cooling is present and the humidistat is open.

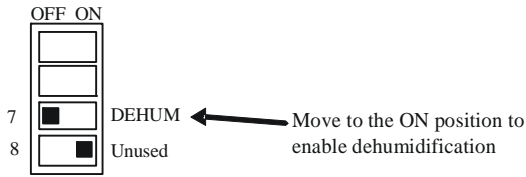

**Electric Heater Airflow** - Airflow for installed electric heaters is set by adjusting the dipswitches to the appropriate heater size.

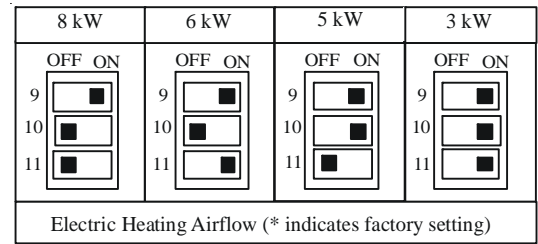
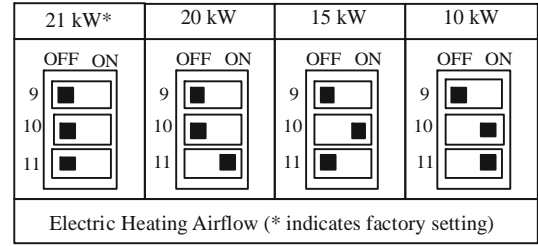

The table below indicates the airflow that corresponds to the available dipswitch settings.

**MBVC Airflow Table**

| Speed Selection Dip Switches  |                         |     |                           |     |                            |     |            | Htr Kw     | 9              | 10  | 11              | MBVC1200* | MBVC16000* | MBVC2000* |
|---|-------------------------|-----|---------------------------|-----|----------------------------|-----|------------|------------|----------------|-----|-----------------|-----------|------------|-----------|
|   | Cool Selection Switches |     | Adjust Selection Switches |     | Profile Selection Switches |     |            | 3          | ON             | ON  | ON              | 600       | 800        | 800       |
|   |                         |     |                           |     |                            |     | 5          | ON         | ON             | OFF | 600             | 800       | 800        |           |
| TAP   | 1                       | 2   | 3                         | 4   | 5                          | 6   | 6          | ON         | OFF            | ON  | 635             | 800       | 800        |           |
| A   | OFF                     | OFF | OFF                       | OFF | OFF                        | OFF | 8          | ON         | OFF            | OFF | 740             | 1000      | 1000       |           |
| B   | ON                      | OFF | ON                        | OFF | ON                         | OFF | 10         | OFF        | ON             | ON  | 1000            | 1000      | 1200       |           |
| C   | OFF                     | ON  | OFF                       | ON  | OFF                        | ON  | 15         | OFF        | ON             | OFF | 1400            | 1500      | 1500       |           |
| D   | ON                      | ON  | ON                        | ON  | ON                         | ON  | 20         | OFF        | OFF            | ON  | NR              | NR        | 2000       |           |
| Profiles  | Pre-Run                 |     | Short-Run                 |     | OFF Delay                  |     | Model      | Tap        | Low Stage Cool |     | High Stage Cool |           |            |           |
| A   | -----                   |     | -----                     |     | 60 sec/100%                |     | MBVC1200 * | A          | 400            |     | 600             |           |            |           |
| B   | -----                   |     | 30 sec/50%                |     | 60 sec/100%                |     |            | B          | 540            |     | 800             |           |            |           |
| C   | -----                   |     | 7.5 min/82%               |     | 60 sec/100%                |     |            | C          | 670            |     | 1000            |           |            |           |
| D   | 30 sec/50%              |     | 7.5 min/82%               |     | 30 sec/50%                 |     |            | D          | 800            |     | 1200            |           |            |           |
| To set airflow: (1) Select model and desired high stage cooling airflow. Determine the corresponding tap (A, B, C, or D). Set dip switches 1 and 2 to the appropriate ON / OFF positions. (2) Select model and installed electric heater size. Set switches 9, 10, and 11 to the appropriate ON/OFF positions. (3) Select the airflow adjustment factor tap. A and D are 0%; Tap B is +10%; Tap C -10%. Set dip switches 3 and 4 to the appropriate ON / OFF positions. |                         |     |                           |     |                            |     |            | MBVC1600 * |                | A   | 670             |           | 1000       |           |
|   |                         |     |                           |     |                            |     |            |            |                | B   | 800             |           | 1200       |           |
|   |                         |     |                           |     |                            |     |            |            |                | C   | 940             |           | 1400       |           |
|   |                         |     |                           |     |                            |     |            |            |                | D   | 1070            |           | 1600       |           |
| To set Comfort Mode: Select desired Comfort Mode profile (see profiles above). Set switches 5 and 6 to the appropriate ON / OFF positions.  |                         |     |                           |     |                            |     |            | MBVC2000 * |                | A   | 800             |           | 1200       |           |
|   |                         |     |                           |     |                            |     |            |            |                | B   | 1070            |           | 1600       |           |
|   |                         |     |                           |     |                            |     |            |            |                | C   | 1200            |           | 1800       |           |
|   |                         |     |                           |     |                            |     |            |            |                | D   | 1340            |           | 2000       |           |

# SERVICING

## AVPTC Airflow Table

**Speed Selection Dip Switches**

| Tap | 1   | 2   |
|-----|-----|-----|
| A   | OFF | OFF |
| B   | ON  | OFF |
| C   | OFF | ON  |
| D   | ON  | ON  |

| TRIM  | 3   | 4   |
|-------|-----|-----|
| 0%    | OFF | OFF |
| + 10% | ON  | OFF |
| - 10% | OFF | ON  |
| 0%    | ON  | ON  |

**TO SET AIRFLOW:**

- Select appropriate model from Cooling/Heat Pump Airflow Table. Based on desired Airflow for your application select corresponding tap (A,B,C or D). Set dip switches 1 & 2 to the appropriate ON/OFF positions.
- Select appropriate Airflow adjustment factor for application (0%, +10%, -10%). Set dip switches 3 & 4 to the appropriate ON/OFF positions.
- If installed with Heater Kit:*  
Using Electric Heat Airflow Table, set dip switches 9, 10 and 11 to the appropriate ON/OFF positions based on Heater kit installed.  
*If installed without Heater Kit:*  
Ensure dip switches 9, 10 and 11 are set to a valid heater kit selection. Example: The only valid heater kits for AVPTC183014\* applications are 3, 5, 6, 8 and 10 kW.  
*Failure to do so will result in a Heater Kit error code.*

**TO SET COMFORT MODE:**  
Select desired Comfort Mode profile (see profiles above). Set switches 5 and 6 to the appropriate ON/OFF positions.

|          |            | Profile Selection Switches |             |     |     |
|----------|------------|----------------------------|-------------|-----|-----|
| Profiles | Pre-Run    | Short-Run                  | Off Delay   | 5   | 6   |
| A        | -----      | -----                      | 60 sec/100% | OFF | OFF |
| B        | -----      | 30 sec/50%                 | 60 sec/100% | ON  | OFF |
| C        | -----      | 7.5 mins/82%               | 60 sec/100% | OFF | ON  |
| D        | 30 sec/50% | 7.5 mins/82%               | 30 sec/50%  | ON  | ON  |

| Cooling/Heat Pump Airflow Table |     |                |                 |
|---------------------------------|-----|----------------|-----------------|
| Model                           | Tap | Low Stage Cool | High Stage Cool |
| AVPTC183014*                    | A   | 420            | 630             |
|                                 | B   | 560            | 840             |
|                                 | C   | 700            | 1040            |
| AVPTC313714*                    | A   | 410            | 610             |
|                                 | B   | 560            | 830             |
|                                 | C   | 700            | 1040            |
|                                 | D   | 830            | 1240            |
| AVPTC426014*                    | A   | 810            | 1210            |
|                                 | B   | 940            | 1410            |
|                                 | C   | 1050           | 1560            |
|                                 | D   | 1210           | 1800            |

NOTE: Airflow data shown applies to non-communicating mode operation only. For a fully communicating system, please see the outdoor unit's installation instructions for cooling and heat pump airflow data. See *ComfortNet™ System - Airflow Consideration section for details.*

| Electric Heat Airflow Table |     |     |     |               |               |               |
|-----------------------------|-----|-----|-----|---------------|---------------|---------------|
| Htr kW                      | 9   | 10  | 11  | AVPTC 183014* | AVPTC 313714* | AVPTC 426014* |
| 3                           | ON  | ON  | ON  | 630           | 610           | 600           |
| 5                           | ON  | ON  | OFF | 730           | 710           | 680           |
| 6                           | ON  | OFF | ON  | 840           | 840           | 790           |
| 8                           | ON  | OFF | OFF | 1080          | 1060          | 990           |
| 10                          | OFF | ON  | ON  | 1270          | 1260          | 1190          |
| 15                          | OFF | ON  | OFF | NR            | 1470          | 1390          |
| 20                          | OFF | OFF | ON  | NR            | NR            | 1580          |
| 21                          | OFF | OFF | OFF | NR            | NR            | 1580          |

NOTE: Airflow data shown applies to the emergency heat mode (electric heat only) in either non-communicating mode operation or fully communicating mode operation.

**NOTE:** When 8kW and 10kW heat kits are used with an AVPTC1830 and AVPTC313, matched with 2-ton outdoor unit, see Note 1 below.

- Set Heater Kit dip switches 9, 10 and 11 to 6kW setting (9-ON, 10-OFF, 11-ON) to obtain 840 CFM.

# SERVICING

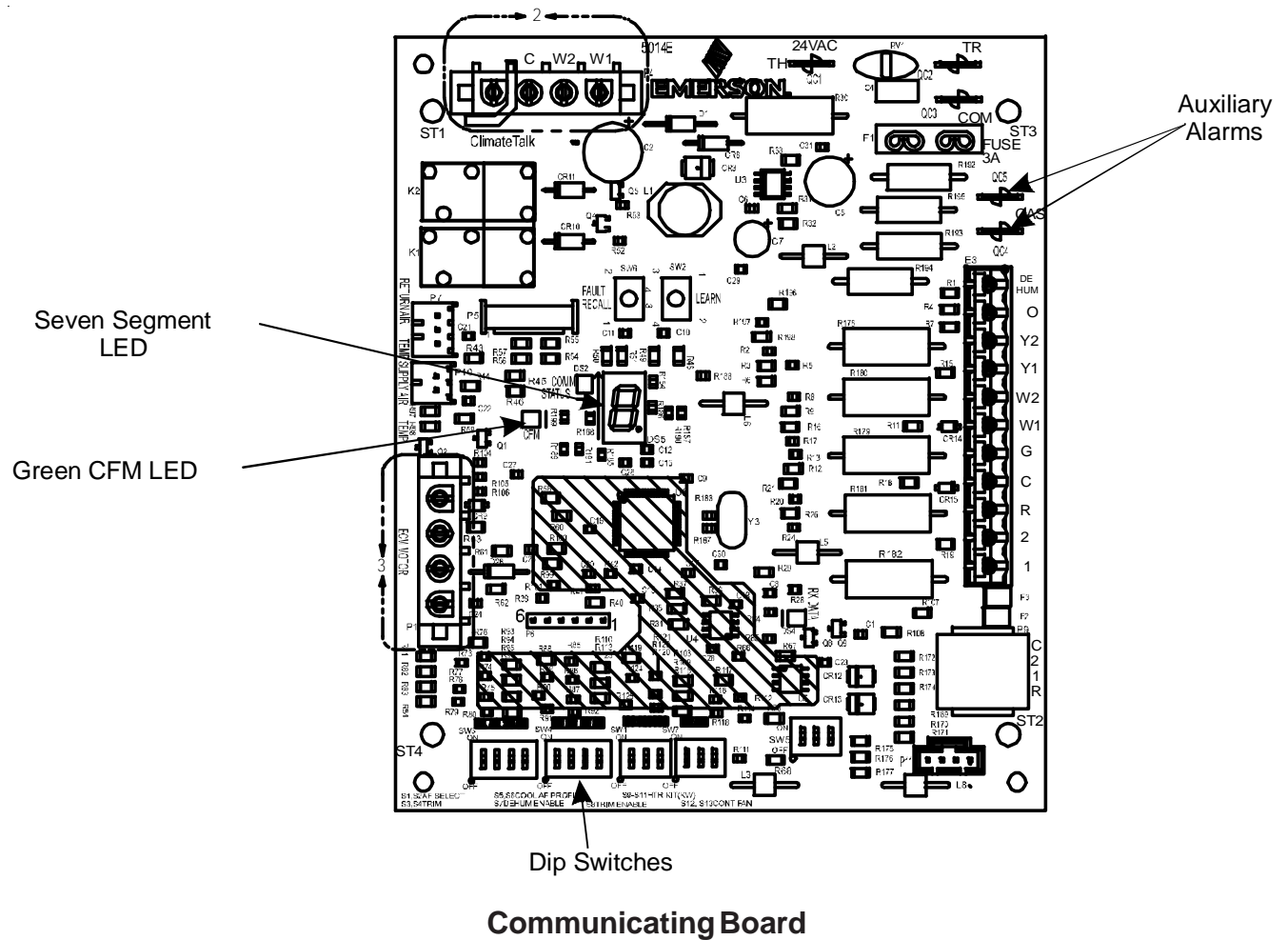

## CIRCULATOR BLOWER

This air handler is equipped with a multi-speed circulator blower. This blower provides ease in adjusting blower speeds. The Specification Sheet applicable to your model provides an airflow table, showing the relationship between airflow (CFM) and external static pressure (E.S.P.), for the proper selection of heating and cooling speeds. The heating blower speed is shipped set at 21kW or 25kW, and the cooling blower speed is set at “D”. These blower speeds should be adjusted by the installer to match the installation requirements so as to provide the correct electric heating CFM and correct cooling CFM.

Use the CFM LED (green) to obtain an approximate airflow quantity. The green CFM LED blinks once for each 100 CFM of airflow.

1. Determine the tonnage of the cooling system installed with the air handler. If the cooling capacity is in BTU/hr divide it by 12,000 to convert capacity to TONS.

**Example:** Cooling Capacity of 30,000 BTU/hr.  
 $30,000/12,000 = 2.5$  Tons

2. Determine the proper air flow for the cooling system. Most cooling systems are designed to work with air flows between 350 and 450 CFM per ton. Most manufacturers recommend an air flow of about 400 CFM per ton.

**Example:** 2.5 tons X 400 CFM per ton = 1000 CFM

The cooling system manufacturer’s instructions must be checked for required air flow. Any electronic air cleaners or other devices may require a specific airflow; consult installation instructions of those devices for requirements.

3. Knowing the air handler model, locate the high stage cooling air flow charts in the Specification Sheet applicable to your model. Look up the cooling air flow determined in step 2 and find the required cooling speed and adjustment setting.

**Example:** An AVPTC30C14 air handler installed with a 2.5 ton air conditioning system. The air flow needed is 1000 CFM. Looking at the cooling speed chart for AVPTC30C14, find the air flow closest to 1000 CFM. A cooling airflow of 1000 CFM can be attained by setting the cooling speed to “C” and the adjustment to “0” (no adjustment).

# SERVICING

4. Locate the blower speed selection DIP switches on the integrated control module. Select the desired “cooling” speed tap by positioning switches 1 and 2 appropriately. If airflow adjustment is required, set dip switch S8 (trim enable) to ON (trim enable default is off). Then select the desired “adjust” tap by positioning switches 3 and 4 appropriately. Refer to the following *Dipswitches - Cooling Airflow and Airflow Adjust Taps* figure for switch positions and their corresponding taps. Verify CFM by counting the number of times the green CFM LED blinks.

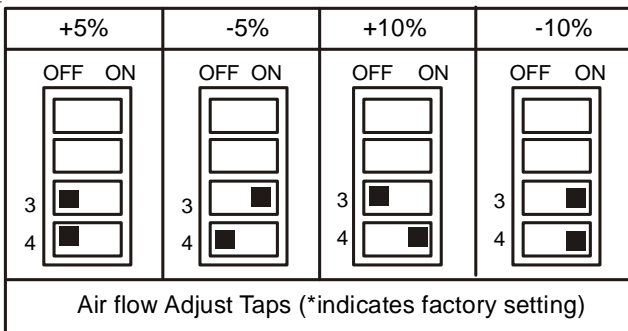
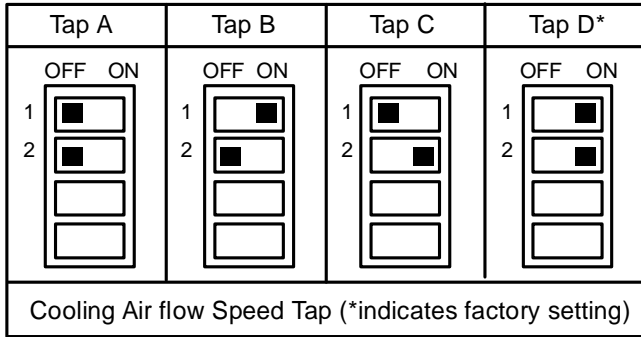

## Dip Switches - Cooling Airflow and Airflow Adjust Taps

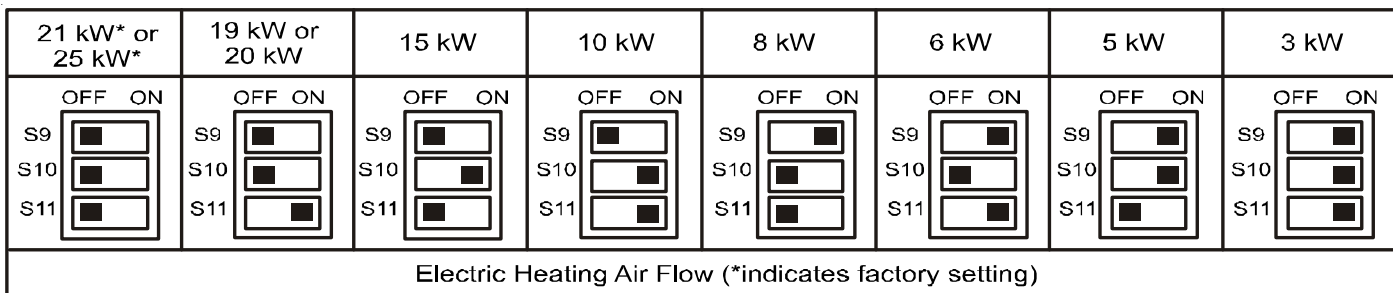

5. Continuous fan speeds that provide 25, 50, 75, and 100% of the furnace’s maximum airflow capability are selectable via dip switches S12 and S13.

If the furnace’s maximum airflow capability is 2000 CFM and 25% continuous fan speed is selected, the continuous fan speed will be  $0.25 \times 2000 \text{ CFM} = 500 \text{ CFM}$ .

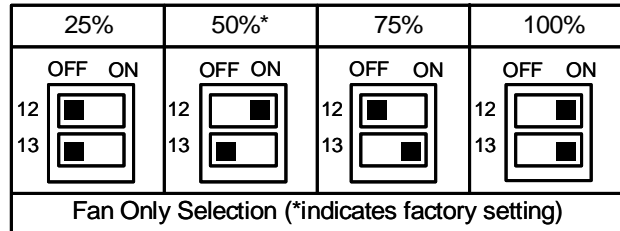

6. The multi-speed circulator blower also offers several custom ON/OFF ramping profiles. These profiles may be used to enhance cooling performance and increase comfort level. The ramping profiles are selected using DIP switches 5 and 6. Refer to the following *Dipswitches - Cooling Airflow Ramping Profiles* figure for switch positions and their corresponding taps. Refer to the bullet points below for a description of each ramping profile. Verify profile selection by counting the green CFM LED blinks and timing each step of the ramping profile.

**NOTE:** Upon start up in communicating mode the circuit board may display an “Ec” error. This is an indication that the dip switches on the control board need to be configured in accordance with the Electric Heating Airflow Table. Configuring the dip switches and resetting power to the unit will clear the error code.

Within the thermostat user menu, CTK0\* communicating thermostat will display 20 kW for OFF-OFF-ON dip switch selection and 21 kW for OFF-OFF-OFF dip switch selection.

# SERVICING

- Profile A provides only an OFF delay of one (1) minute at 100% of the cooling demand airflow.

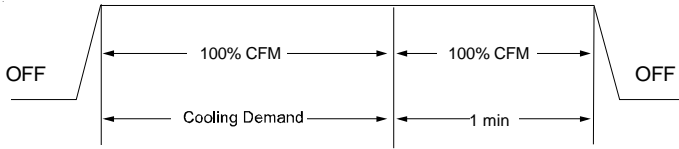

- Profile B ramps up to full cooling demand airflow by first stepping up to 50% of the full demand for 30 seconds. The motor then ramps to 100% of the required airflow. A one (1) minute OFF delay at 100% of the cooling airflow.



- Profile C ramps up to 82% of the full cooling demand airflow and operates there for approximately 7 1/2 minutes. The motor then steps up to the full demand airflow. Profile C also has a one (1) minute 100% OFF delay.

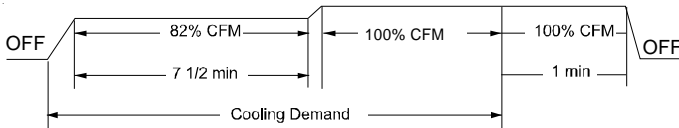

- Profile D ramps up to 50% of the demand for 1/2 minute, then ramps to 82% of the full cooling demand airflow and operates there for approximately 7 1/2 minutes. The motor then steps up to the full demand airflow. Profile D has a 1/2 minute at 50% airflow OFF delay.

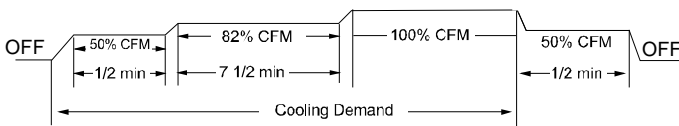

7. If an electric heater kit has been installed, determine the heater kilowatt (kW) rating. Find the heater size in the table below. Set dip switches 9, 10, and 11 for the installed heater as shown in the *Dipswitches - Electric Heat Airflow* table on the previous page. The adjust setting (already established by the cooling speed selection) also applies to the electric heater kit airflow. Thus, the electric heater airflow is adjusted by the same amount. Verify selected CFM by counting the green CFM LED blinks.

If an electric heater kit has not been installed, set dip switches 9, 10, and 11 to any valid heater kit setting (see airflow table for valid settings). This will prevent an Ec Error code from being displayed.

**NOTE: For installations not indicated in the preceding Temperature Rise Tables, the following formula is to be used:**

$$TR = (kW \times 3412) \times (\text{Voltage Correction}) \times (1.08 \times CFM)$$

Where: TR = Temperature Rise

kW = Heater Kit Actual kW

3412 = Btu per kW

Voltage Correction = .96 (230 Supply Volts)

= .92 (220 Supply Volts)

= .87 (208 Supply Volts)

1.08 = Constant

CFM = Measured Airflow

**NOTE:** The Temperature Rise Tables can also be used to determine the air handler airflow delivery. When using these tables for this purpose set the room thermostat to maximum heat and allow the system to reach steady state conditions. Insert two thermometers, one in the return air and one in the supply air. The temperature rise is the supply air temperature minus the room air temperature.

Use HKR specification sheets to determine the HKR available for a given air handler.

| Tap A*   | Tap B   | Tap C  | Tap D   |
|--|---|--|---|
| OFF ON<br>S5 <input checked="" type="checkbox"/><br>S6 <input checked="" type="checkbox"/> | OFF ON<br>S5 <input type="checkbox"/><br>S6 <input checked="" type="checkbox"/> | OFF ON<br>S5 <input checked="" type="checkbox"/><br>S6 <input checked="" type="checkbox"/> | OFF ON<br>S5 <input type="checkbox"/><br>S6 <input checked="" type="checkbox"/> |
| Cooling Air flow Ramping Profiles (*indicates factory setting)                             |   |  |   |

## Dipswitches - Cooling Airflow Ramping Profiles

# SERVICING

## Speed Selection Dip Switches

| TAP | Cool Selection Switches |     | Adjust Selection Switches |     | Profile Selection Switches |     | Continuous Fan Speed |     |
|-----|-------------------------|-----|---------------------------|-----|----------------------------|-----|----------------------|-----|
|     | S1                      | S2  | S3                        | S4  | S5                         | S6  | S12                  | S13 |
| A   | OFF                     | OFF | OFF                       | OFF | OFF                        | OFF | OFF                  | OFF |
| B   | ON                      | OFF | ON                        | OFF | ON                         | OFF | ON                   | OFF |
| C   | OFF                     | ON  | OFF                       | ON  | OFF                        | ON  | OFF                  | ON  |
| D   | ON                      | ON  | ON                        | ON  | ON                         | ON  | ON                   | ON  |

| Profiles | Pre-Run    | Short-Run   | OFF Delay   |
|----------|------------|-------------|-------------|
| A        | -----      | -----       | 60 sec/100% |
| B        | -----      | 30 sec/50%  | 60 sec/100% |
| C        | -----      | 7.5 min/82% | 60 sec/100% |
| D        | 30 sec/50% | 7.5 min/82% | 30 sec/50%  |

**To set Airflow:** (1) Select model and desired High Stage Cooling Airflow. Determine the corresponding tap (A, B, C, D). Set dip switches S1 and S2 to the appropriate ON / OFF positions. (2) Select model and installed electric heater size. Set dip switches S9, S10, and S11 to the appropriate ON / OFF positions. (3) If airflow adjustment is required set Trim Enable Switch **S8** to ON (OFF = 0% Trim) and set S3 and S4 to appropriate ON / OFF positions. Tap A is +5%, Tap B is -5%, Tap C is +10%, Tap D is -10%.

**To Set Comfort mode:** Select desired Comfort Mode Profile (see profiles above). Set dip switches S5 and S6 to appropriate ON / OFF positions.

**Dehumidification:** To enable, set dip switch S7 to ON. Cooling airflow will be reduced to 85% of nominal value during cool call when Dehum command is present. To disable, set S7 to OFF.

**Continuous Fan Speed:** Use dip switches S12 and S13 to select one of 4 continuous fan speeds, Tap A is 25%. Tap B is 50%, Tap C is 75%, Tap D is 100%.

**Notes:**

- Airflow data shown applies to legacy mode operation only. For a fully communicating system, please see the outdoor unit's installation instructions for cooling and heat pump airflow data. See *ComfortNet System-Airflow Consideration* section for details.
- Airflow blink codes are approximations of actual airflow.

## Cooling/Heat Pump Airflow Table

| Model        | Speed tap | Low stage (CFM) | High stage (CFM) |
|--------------|-----------|-----------------|------------------|
| AVPTC24B14** | A         | 410             | 610              |
|              | B         | 565             | 835              |
|              | C         | 660             | 970              |
|              | D         | 765             | 1125             |
| AVPTC30C14** | A         | 440             | 610              |
|              | B         | 605             | 835              |
|              | C         | 740             | 1020             |
|              | D         | 885             | 1225             |
| AVPTC36C14** | A         | 500             | 725              |
|              | B         | 700             | 1000             |
|              | C         | 930             | 1330             |
|              | D         | 1120            | 1600             |
| AVPTC48C14** | A         | 500             | 725              |
|              | B         | 700             | 1000             |
|              | C         | 930             | 1330             |
|              | D         | 1120            | 1600             |
| AVPTC42D14** | A         | 560             | 800              |
|              | B         | 763             | 1090             |
|              | C         | 994             | 1420             |
|              | D         | 1225            | 1750             |
| AVPTC48D14** | A         | 900             | 1350             |
|              | B         | 1035            | 1550             |
|              | C         | 1140            | 1700             |
|              | D         | 1200            | 1800             |
| AVPTC60D14** | A         | 1210            | 1610             |
|              | B         | 1365            | 1815             |
|              | C         | 1450            | 1920             |
|              | D         | 1525            | 2025             |

**NOTE:** Airflow blink codes are approximations of actual airflow. Airflows provided are at 0.3 static.

# SERVICING

| ELECTRIC HEAT AIRFLOW TABLE |     |     |     |              |              |              |             |               |                |                 |
|-----------------------------|-----|-----|-----|--------------|--------------|--------------|-------------|---------------|----------------|-----------------|
| Htr kW                      | 9   | 10  | 11  | AVPTC24B14A* | AVPTC30C14A* | AVPTC36C14A* | AVPTC48C14* | AVPTC42D14A** | AVPTC48D14A*** | AVPTC60D14A**** |
| 3                           | ON  | ON  | ON  | 550          | 600          | NR           | NR          | 850**         | NR             | NR              |
| 5                           | ON  | ON  | OFF | 650          | 700          | 850          | 850         | 1250          | 1250           | 1250            |
| 6                           | ON  | OFF | ON  | 700          | 750          | 900          | 900         | 1300          | 1300           | 1300            |
| 8                           | ON  | OFF | OFF | 800          | 875          | 1000         | 1000        | 1500          | 1500           | 1500            |
| 10                          | OFF | ON  | ON  | 850          | 950          | 1200         | 1200        | 1550          | 1550           | 1550            |
| 15                          | OFF | ON  | OFF | NR           | NR           | 1440         | 1440        | 1720          | 1720           | 1780            |
| 19*                         | OFF | OFF | ON  | NR           | NR           | 1500         | 1500        | NR            | NR             | NR              |
| 20                          | OFF | OFF | ON  | NR           | NR           | 1500         | 1500        | 1800          | 1815           | 1850            |
| 21 or 25*                   | OFF | OFF | OFF | NR           | NR           | NR           | NR          | NR            | 1850           | 1850            |

**NOTE:** Airflow data shown applies to the electric heat only in either legacy mode or communicating mode operation.

\* Within thermostat user menu, CTK0\* communicating thermostat will display 20 kW for OFF-OFF-ON dip switch selection and 21 kW for OFF- OFF-OFF dip switch selection.

NR- Not rated

\*For match up with a 2 ton outdoor unit: Heater kit application shall not exceed 10 kW.

Airflow for 5 kW up to 10 kW heater kits shall be set to 850 cfm speed tap of ON-ON-ON.

\*\*For match up with a 3 ton outdoor unit: Heater kit application shall not exceed 15 kW.

Airflow for 5 kW up to 15 kW heater kits shall be set to 1300 cfm speed tap of ON-OFF-ON.

\*\*\*For match up with a 3.5 ton outdoor unit: Heater kit application shall not exceed 20 kW.

Airflow for 5 kW up to 20 kW heater kits shall be set to 1500 cfm speed tap of ON-OFF-OFF

\*\* 3 kW heater kit is not applicable for this indoor application.

## Heat Kit Selection

| Models       | HKX03XC | HKX05XC | HKX08XC | HKX08XC | HKX10XC | HKX15XF* | HKX20XF* | HKSC05XC | HKSC08XC | HKSC10XC | HKSC15XA | HKSC15XB | HKSC15XF | HKSC19CA | HKSC19CB | HKSC20DA | HKSC20DB | HKSC20XF* | HKSC25XF | HKSC25DC |
|--------------|---------|---------|---------|---------|---------|----------|----------|----------|----------|----------|----------|----------|----------|----------|----------|----------|----------|-----------|----------|----------|
| AVPTC24B14A* | X       | X       | X       | X       | X       |          |          | X        | X        | X        |          |          |          |          |          |          |          |           |          |          |
| AVPTC30C14A* | X       | X       | X       | X       | X       |          |          | X        | X        | X        |          |          |          |          |          |          |          |           |          |          |
| AVPTC36C14A* |         | X       | X       | X       | X       | X        | X        | X        | X        | X        | X        | X        | X        | X        | X        |          |          | X         | X        |          |
| AVPTC48C14A* |         | X       | X       | X       | X       | X        | X        | X        | X        | X        | X        | X        | X        | X        | X        |          |          | X         | X        |          |
| AVPTC42D14A* |         | X       | X       | X       | X       | X        | X        | X        | X        | X        | X        | X        | X        |          |          | X        | X        | X         | X        |          |
| AVPTC48D14A* |         | X       | X       | X       | X       | X        | X        | X        | X        | X        | X        | X        | X        |          |          | X        | X        | X         | X        | X        |
| AVPTC60D14A* |         | X       | X       | X       | X       | X        | X        | X        | X        | X        | X        | X        | X        |          |          | X        | X        | X         | X        | X        |

\* Revision level that may or may not be designated.

C Circuit breaker option.

**NOTE:** Airflow selection should meet the minimum requirements as mentioned in Table 5.

# SERVICING

## TROUBLESHOOTING

### ELECTROSTATIC DISCHARGE (ESD) PRECAUTIONS

**NOTE:** Discharge body's static electricity before touching unit. An electrstaic can adversely affect electrical components.

Use the following precautions during air handler installation and servicing to protect the integrated control module from damage. By putting the air handler, the control, and ther person at the same electrostatic potential, these steps will help avoid exposing the integrated control module to electrostatic discharge. This procedure is applicable to both installed and uninstalled (ungrounded) blowers.

1. Disconnect all power to the blower. Do not touch the integrated control module or any wire connected to the control prior to discharging your body's electrostatic charge to ground.
2. Firmly touch a clean, unpainted, metal surface of the air handler blower near the control. Any tools held in a person's hand during grounding will be discharged.
3. Service integrated control module or connecting wiring following the discharge process in step 2. Use caution not to recharge your body with static electricity; (i.e., do not move or shuffle your feet, do not touch ungrounded objects, etc.). If you come in contact with an ungrounded object, repeat step 2 before touching control or wires.
4. Discharge your body to ground before removing a new control from its container. Follow steps 1 through 3 if installing the control on a blower. Return any old or new controls to their containers before touching any ungrounded object.

## DIAGNOSTIC CHART

 **WARNING**

**HIGH VOLTAGE!**

TO AVOID PERSONAL INJURY OR DEATH DUE TO ELECTRICAL SHOCK, DISCONNECT ELECTRICAL POWER BEFORE PERFORMING ANY SERVICE OR MAINTENANCE.



Refer to the *Troubleshooting Chart* at the end of this manual for assistance in determining the source of unit operational problems. The 7 segment LED display will provide any active fault codes. An arrow printed next to the display indicates proper orientation (arrow points to top of display). See following image.

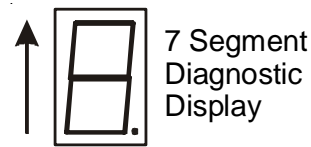



# SERVICING

## COMMUNICATIONS TROUBLESHOOTING CHART

| LED                    | LED Status     | Indication   | Possible Causes   | Corrective Action(s)  | Notes & Cautions  |
|------------------------|----------------|--|---|---|---|
| Red Communications LED | Off            | <ul style="list-style-type: none"> <li>Normal condition</li> </ul>                       | <ul style="list-style-type: none"> <li>None</li> </ul>  | <ul style="list-style-type: none"> <li>None</li> </ul>  | <ul style="list-style-type: none"> <li>None</li> </ul>  |
|                        | 1 Flash        | <ul style="list-style-type: none"> <li>Communications Failure</li> </ul>                 | <ul style="list-style-type: none"> <li>Communications Failure</li> </ul>  | <ul style="list-style-type: none"> <li>Depress Learn Button</li> <li>Verify that bus BIAS and TERM dipswitches are in the ON position.</li> </ul>   | <ul style="list-style-type: none"> <li>Depress once quickly for a power-up reset</li> <li>Depress and hold for 2 seconds for an out-of-box reset</li> </ul>   |
|                        | 2 Flashes      | <ul style="list-style-type: none"> <li>Out-of-box reset</li> </ul>                       | <ul style="list-style-type: none"> <li>Control power up</li> <li>Learn button depressed</li> </ul>  | <ul style="list-style-type: none"> <li>None</li> </ul>  | <ul style="list-style-type: none"> <li>None</li> </ul>  |
| Green Receive LED      | Off            | <ul style="list-style-type: none"> <li>No power</li> <li>Communications error</li> </ul> | <ul style="list-style-type: none"> <li>No power to air handler</li> <li>Open fuse</li> <li>Communications error</li> </ul>  | <ul style="list-style-type: none"> <li>Check fuses and circuit breakers; replace/reset</li> <li>Replace blown fuse</li> <li>Check for shorts in low voltage wiring in air handler/system</li> <li>Reset network by depressing learn button</li> <li>Check data 1/ data 2 voltages</li> </ul>  | <ul style="list-style-type: none"> <li>Turn power OFF prior to repair</li> </ul>  |
|                        | 1 Steady Flash | <ul style="list-style-type: none"> <li>No network found</li> </ul>                       | <ul style="list-style-type: none"> <li>Broken/ disconnected data wire(s)</li> <li>Air handler is installed as a non-communicating/ traditional system</li> </ul>  | <ul style="list-style-type: none"> <li>Check communications wiring (data 1/ data 2 wires)</li> <li>Check wire connections at terminal block</li> <li>Verify air handler installation type (non-communicating/ traditional or communicating)</li> <li>Check data 1/ data 2 voltages</li> </ul> | <ul style="list-style-type: none"> <li>Turn power OFF prior to repair</li> <li>Verify wires at terminal blocks are securely twisted together prior to inserting into terminal block</li> <li>Verify data1 and data voltages as described above</li> </ul> |
|                        | Rapid Flashing | <ul style="list-style-type: none"> <li>Normal network traffic</li> </ul>                 | <ul style="list-style-type: none"> <li>Control is "talking" on network as expected</li> </ul>   | <ul style="list-style-type: none"> <li>None</li> </ul>  | <ul style="list-style-type: none"> <li>None</li> </ul>  |
|                        | On Solid       | <ul style="list-style-type: none"> <li>Data 1/ Data 2 miss-wire</li> </ul>               | <ul style="list-style-type: none"> <li>Data 1 and data 2 wires reversed at air handler, thermostat, or ComfortNet™ compatible outdoor AC/HP</li> <li>Short between data 1 and data 2 wires</li> <li>Short between data 1 or data 2 wires and R (24VAC) or C (24VAC common)</li> </ul> | <ul style="list-style-type: none"> <li>Check communications wiring (data 1/ data 2 wires)</li> <li>Check wire connections at terminal block</li> <li>Check data 1/ data 2 voltages</li> </ul>   | <ul style="list-style-type: none"> <li>Turn power OFF prior to repair</li> <li>Verify wires at terminal blocks are securely twisted together prior to inserting into terminal block</li> <li>Verify data1 and data voltages as described above</li> </ul> |

# SERVICING

## DIAGNOSTIC CODES for PCBJA103 Board

| 7 SEGMENT LED<br>(characters will alternate)  | DESCRIPTION OF CONDITION  |
|---|---|
| (no display)  | INTERNAL CONTROL FAULT / NO POWER   |
| On  | STANDBY, WAITING FOR INPUTS   |
| Ec  | HEATER KIT TOO LARGE, TOO SMALL, OR NO MATCH  |
| E5  | FUSE OPEN   |
| EF  | AUXILIARY SWITCH OPEN   |
| d0  | DATA NOT ON NETWORK   |
| d1  | INVALID DATA ON NETWORK   |
| d4  | INVALID MEMORY CARD DATA  |
| b0  | BLOWER MOTOR NOT RUNNING  |
| b1  | BLOWER MOTOR COMMUNICATION ERROR  |
| b2  | BLOWER MOTOR HP MISMATCH  |
| b3  | BLOWER MOTOR OPERATING IN POWER, TEMP., OR SPEED LIMIT                                    |
| b4  | BLOWER MOTOR CURRENT TRIP OR LOST ROTOR   |
| b5  | BLOWER MOTOR ROTOR LOCKED   |
| b6  | OVER/UNDER VOLTAGE TRIP OR OVER TEMPERATURE TRIP  |
| b7  | INCOMPLETE PARAMETER SENT TO MOTOR  |
| b9  | LOW INDOOR AIRFLOW  |
| C1  | LOW STAGE COOL - LEGACY MODE ONLY   |
| C2  | HIGH STAGE COOL - LEGACY MODE ONLY  |
| P1  | LOW STAGE HEAT PUMP HEAT - LEGACY MODE ONLY   |
| P2  | HIGH STAGE HEAT PUMP HEAT - LEGACY MODE ONLY  |
| h1  | EMERGENCY HEAT LOW - COMMUNICATING MODE ONLY  |
| h2  | EMERGENCY HEAT HIGH - COMMUNICATING MODE ONLY   |
| FC  | FAN COOL - COMMUNICATING MODE ONLY  |
| FH  | FAN HEAT - COMMUNICATING MODE ONLY  |
| F   | FAN ONLY  |
| H1  | ELECTRIC HEAT LOW   |
| H2  | ELECTRIC HEAT HIGH  |
| dF  | DEFROST - COMMUNICATING MODE ONLY<br>(Note: defrost is displayed as H1 in a legacy setup) |
| <p>GREEN CFM LED - EACH FLASH REPRESENTS 100CFM (USE FOR AIRFLOW APPROXIMATION ONLY) - EXAMPLE: 8 FLASHES = 800CFM</p> <p style="text-align: right;">0140A00070-A</p> |   |

# SERVICING

| 7-Segment LED Codes Characters W11 Alternate   |                     | ComfortNet™ Thermostat Only   |                                  | Possible Causes   |   | Corrective Actions   |  | Notes & Cautions |  |
|--|---------------------|---|----------------------------------|---|---|--|--|------------------|--|
| Symptoms of Abnormal Operation (Legacy & ComfortNet™ Thermostat)   |                     | Fault Description   |                                  | Message   |   | Code   |  |                  |  |
| <ul style="list-style-type: none"> <li>LED display is ON continuously</li> <li>Electric heaters fail to energize on a call for W1 or Auxiliary/Emergency heat</li> <li>Integrated control module LED display provides the indicated error code.</li> <li>ComfortNet™ thermostat "Call for Service" icon illuminated</li> <li>ComfortNet™ thermostat scrolls "Check Air Handler" message</li> </ul> | <p>ON</p> <p>EC</p> | <ul style="list-style-type: none"> <li>Normal operation</li> <li>Heater kit selected via dipswitches is too large for heater kits specified in shared data set</li> </ul> | <p>None</p> <p>HTR TOO LARGE</p> | <ul style="list-style-type: none"> <li>Normal operation</li> <li>Heater kit selected via dipswitches is too large for heater kits in shared data set</li> </ul> | <p>None</p> <ul style="list-style-type: none"> <li>Verify electric heat dipswitch settings</li> <li>Verify the installed electric heater is valid for the air handler blower. Check nameplate or Specification Sheet applicable to your model* for allowable heater kit(s).</li> <li>Verify shared data set is correct for the specific model. Re-populate data using correct memory card if required.</li> </ul> | <ul style="list-style-type: none"> <li>Normal operation</li> <li>Turn power OFF prior to repair.</li> <li>Use memory card for the specific model.</li> <li>Insert memory card BEFORE turning power ON. Memory cards may be removed after data is loaded.</li> <li>Turn power off before removing memory card.</li> </ul> |  |                  |  |
| <ul style="list-style-type: none"> <li>Electric heat airflow is higher than expected on a call for W1 or Auxiliary/Emergency heat</li> <li>Integrated control module LED display provides the indicated error code.</li> </ul>   | <p>EC</p>           | <ul style="list-style-type: none"> <li>Heater kit selected via dipswitches is too small for heater kits specified in shared data set</li> </ul>                           | <p>HTR TOO SMALL</p>             | <ul style="list-style-type: none"> <li>Heater kit selected via dipswitches is too small for heater kits in shared data set</li> </ul>                           | <ul style="list-style-type: none"> <li>Verify electric heat dipswitch settings</li> <li>Verify the installed electric heater is valid for the air handler blower. Check nameplate or Specification Sheet applicable to your model* for allowable heater kit(s).</li> <li>Verify shared data set is correct for the specific model. Re-populate data using correct memory card if required.</li> </ul>             | <ul style="list-style-type: none"> <li>Turn power OFF prior to repair.</li> <li>Use memory card for the specific model.</li> <li>Insert memory card BEFORE turning power ON. Memory cards may be removed after data is loaded.</li> <li>Turn power off before removing memory card.</li> </ul>                           |  |                  |  |
| <ul style="list-style-type: none"> <li>Electric heat airflow is higher than expected on a call for W1 or Auxiliary/Emergency heat</li> <li>Integrated control module LED display provides the indicated error code.</li> </ul>   | <p>EC</p>           | <ul style="list-style-type: none"> <li>Heater kit selected via dipswitches does not heater kits specified in shared data set</li> </ul>                                   | <p>NO HTR MATCH</p>              | <ul style="list-style-type: none"> <li>Heater kit selected via dipswitches is doesn't match heater kits in shared data set</li> </ul>                           | <ul style="list-style-type: none"> <li>Verify electric heat dipswitch settings</li> <li>Verify the installed electric heater is valid for the air handler blower. Check nameplate or Specification Sheet applicable to your model* for allowable heater kit(s).</li> <li>Verify shared data set is correct for the specific model. Re-populate data using correct memory card if required.</li> </ul>             | <ul style="list-style-type: none"> <li>Turn power OFF prior to repair.</li> <li>Use memory card for the specific model.</li> <li>Insert memory card BEFORE turning power ON. Memory cards may be removed after data is loaded.</li> <li>Turn power off before removing memory card.</li> </ul>                           |  |                  |  |
| <ul style="list-style-type: none"> <li>Integrated control module LED display EF error code.</li> <li>ComfortNet™ thermostat "Call for Service"</li> </ul>  | <p>EF</p>           | <ul style="list-style-type: none"> <li>Aux switch open</li> </ul>   | <p>Aux Alarm Fault</p>           | <ul style="list-style-type: none"> <li>High water level in the evaporation coil.</li> </ul>   | <ul style="list-style-type: none"> <li>Check overflow pan and service</li> </ul>  | <ul style="list-style-type: none"> <li>Turn power OFF prior to service.</li> </ul>   |  |                  |  |

# SERVICING

| Symptoms of Abnormal Operation (Legacy & ComfortNet™ Thermostat)   | 7-Segment LED Codes Characters Will Alternate | Fault Description   | ComfortNet™ Thermostat Only Message Code | Possible Causes  | Corrective Actions   | Notes & Cautions   |
|--|---|---|--|--|--|--|
| <ul style="list-style-type: none"> <li>Air handler blower fails to operate</li> <li>Integrated control module LED display provides no signal.</li> <li>ComfortNet™ thermostat "Call for Service" icon illuminated</li> <li>ComfortNet™ thermostat scrolls "Check Air Handler" message</li> </ul>                             | No Display                                    | <ul style="list-style-type: none"> <li>No 208/230 volt power to air handler blower or no 24 volt power to integrated control module</li> <li>Blown fuse or circuit breaker</li> <li>Integrated control module has an internal fault.</li> </ul> | INTERNAL FAULT<br>EE                     | <ul style="list-style-type: none"> <li>Manual disconnect switch OFF or 24 volt wire improperly connected or loose</li> <li>Blown fuse or circuit breaker</li> <li>Integrated control module has an internal fault</li> </ul> | <ul style="list-style-type: none"> <li>Assure 208/230 volt and 24 volt power to air handler blower and integrated control module.</li> <li>Check integrated control module fuse (3A). Replace if necessary.</li> <li>Check for possible shorts in 208/230 volt and 24 volt circuits. Repair as necessary.</li> <li>Replace bad integrated control module.</li> </ul> | <ul style="list-style-type: none"> <li>Turn power OFF prior to repair.</li> <li>Replace integrated control module fuse with 3A automotive fuse.</li> <li>Replace integrated control module with correct replacement part</li> <li>Read precautions in "Electrostatic Discharge" section of manual.</li> </ul>  |
| <ul style="list-style-type: none"> <li>Air handler blower fails to operate.</li> <li>Integrated control module LED display provides indicated error code.</li> <li>ComfortNet™ thermostat "Call for Service" icon illuminated.</li> <li>ComfortNet™ thermostat scrolls "Check Air Handler" message.</li> </ul>               | d0  | Data not yet on network.  | NO NET DATA<br>d0                        | <ul style="list-style-type: none"> <li>Air handler blower does not contain any shared data.</li> </ul>   | <ul style="list-style-type: none"> <li>Populate shared data set using memory card.</li> </ul>  | <ul style="list-style-type: none"> <li>Turn power OFF prior to repair</li> <li>Use memory card for the specific model.</li> <li>Insert memory card BEFORE turning power ON. Memory card may be removed after data is loaded.</li> <li>Error code will be cleared once data is loaded.</li> <li>Turn power off before removing memory card</li> </ul> |
| <ul style="list-style-type: none"> <li>Air handler blower fails to operate.</li> <li>Integrated control module LED display provides indicated error code.</li> <li>ComfortNet™ thermostat "Call for Service" icon illuminated.</li> <li>ComfortNet™ thermostat scrolls "Check Air Handler" message.</li> </ul>               | d1  | Invalid data on network.  | INVALID DATA<br>d1                       | <ul style="list-style-type: none"> <li>Air handler blower does not contain an appropriate shared data set.</li> </ul>  | <ul style="list-style-type: none"> <li>Populate correct shared data set using memory card.</li> </ul>  | <ul style="list-style-type: none"> <li>Turn power OFF prior to repair</li> <li>Use memory card for the specific model.</li> <li>Insert memory card BEFORE turning power ON. Memory card may be removed after data is loaded.</li> <li>Error code will be cleared once data is loaded.</li> <li>Turn power off before removing memory card</li> </ul> |
| <ul style="list-style-type: none"> <li>Operation different than expected or no operation.</li> <li>Integrated control module LED display provides indicated error code.</li> <li>ComfortNet™ thermostat "Call for Service" icon illuminated.</li> <li>ComfortNet™ thermostat scrolls "Check Air Handler" message.</li> </ul> | d4  | Invalid memory card data.   | INVALID MC DATA<br>d4                    | <ul style="list-style-type: none"> <li>Shared data set on memory card has been rejected by integrated control module</li> </ul>  | <ul style="list-style-type: none"> <li>Verify shared data set is correct for the specific model. Re-populate data using correct memory card if required.</li> </ul>  | <ul style="list-style-type: none"> <li>Turn power OFF prior to repair</li> <li>Use memory card for the specific model.</li> <li>Insert memory card BEFORE turning power ON. Memory card may be removed after data is loaded.</li> <li>Error code will be cleared once data is loaded.</li> <li>Turn power off before removing memory card</li> </ul> |

# SERVICING

| 7-Segment LED Codes Characters WMI Alternates  |    | ComfortNet™ Thermostat Only Message Code   |                | Possible Causes              |  | Corrective Actions  |   | Notes & Cautions   |  |                  |  |
|--|----|--|----------------|------------------------------|--|---|---|--------------------|--|------------------|--|
| Symptoms of Abnormal Operation (Legacy & ComfortNet™ Thermostat)   |    | Fault Description  |                | Thermostat Only Message Code |  | Possible Causes   |   | Corrective Actions |  | Notes & Cautions |  |
| <ul style="list-style-type: none"> <li>Air handler blower fails to operate.</li> <li>Integrated control module LED display provides indicated error code.</li> <li>ComfortNet™ thermostat "Call for Service" icon illuminated.</li> <li>ComfortNet™ thermostat scrolls "Check Air Handler" message.</li> </ul> | b0 | <ul style="list-style-type: none"> <li>Circulator blower motor is not running when it should be running.</li> </ul>  | MOTOR NOT RUN  | b0                           | <ul style="list-style-type: none"> <li>Loose wiring connection at circulator motor power leads or circulator motor power leads disconnected.</li> <li>Failed circulator blower motor.</li> </ul>   | <ul style="list-style-type: none"> <li>Tighten or correct wiring connection.</li> <li>Check circulator blower motor. Replace if necessary.</li> </ul>   | <ul style="list-style-type: none"> <li>Turn power OFF prior to repair.</li> <li>Replace circulator motor with correct replacement part.</li> </ul>  |                    |  |                  |  |
| <ul style="list-style-type: none"> <li>Air handler blower fails to operate.</li> <li>Integrated control module LED display provides indicated error code.</li> <li>ComfortNet™ thermostat "Call for Service" icon illuminated.</li> <li>ComfortNet™ thermostat scrolls "Check Air Handler" message.</li> </ul> | b1 | <ul style="list-style-type: none"> <li>Integrated control module has lost communications with circulator blower motor.</li> </ul>                            | MOTOR COMM     | b1                           | <ul style="list-style-type: none"> <li>Loose wiring connection at circulator motor control leads.</li> <li>Failed circulator blower motor.</li> <li>Failed integrated control module.</li> </ul>   | <ul style="list-style-type: none"> <li>Tighten or correct wiring connection.</li> <li>Check circulator blower motor. Replace if necessary.</li> <li>Check integrated control module. Replace if necessary.</li> </ul>   | <ul style="list-style-type: none"> <li>Turn power OFF prior to repair.</li> <li>Replace circulator motor with correct replacement part.</li> <li>Replace integrated control module with correct replacement part.</li> </ul>  |                    |  |                  |  |
| <ul style="list-style-type: none"> <li>Air handler blower fails to operate.</li> <li>Integrated control module LED display provides indicated error code.</li> <li>ComfortNet™ thermostat "Call for Service" icon illuminated.</li> <li>ComfortNet™ thermostat scrolls "Check Air Handler" message.</li> </ul> | b2 | <ul style="list-style-type: none"> <li>Circulator blower motor horse power in shared data set does not match circulator blower motor horse power.</li> </ul> | MOTOR MISMATCH | b2                           | <ul style="list-style-type: none"> <li>Incorrect circulator blower motor in air handler blower.</li> <li>Incorrect shared data set in integrated control module.</li> </ul>  | <ul style="list-style-type: none"> <li>Verify circulator blower motor horse power is the same specified for the specific air handler blower model. Replace is necessary.</li> <li>Verify shared data set is correct for the specific model. Re-populate data using correct memory card if required.</li> </ul>  | <ul style="list-style-type: none"> <li>Turn power OFF prior to repair.</li> <li>Replace motor with correct replacement part.</li> <li>Use memory card for the specific model.</li> <li>Insert memory card BEFORE turning power ON. Memory card may be removed after data is loaded.</li> <li>Error code will be cleared once shared data and motor horse power match.</li> <li>Turn power off before removing memory card.</li> </ul> |                    |  |                  |  |
| <ul style="list-style-type: none"> <li>Air handler blower operates at reduced performance.</li> <li>Airflow delivered is less than expected.</li> <li>Integrated control module LED display provides b3 error code.</li> </ul>   | b3 | <ul style="list-style-type: none"> <li>Circulator blower motor is operating in a power, temperature, or speed limiting condition.</li> </ul>                 | MOTOR LIMITS   | b3                           | <ul style="list-style-type: none"> <li>Blocked filters.</li> <li>Restrictive ductwork.</li> <li>Undersized ductwork.</li> <li>High ambient temperatures.</li> </ul>  | <ul style="list-style-type: none"> <li>Check filters for blockage. Clean filters or remove obstruction.</li> <li>Check ductwork for blockage. Remove obstruction. Verify all registers are fully open.</li> <li>Verify ductwork is appropriately sized for system. Resize/replace ductwork if necessary.</li> <li>See "Installation Instructions" for installation requirements.</li> </ul> | <ul style="list-style-type: none"> <li>Turn power OFF prior to repair.</li> </ul>   |                    |  |                  |  |
| <ul style="list-style-type: none"> <li>Air handler blower fails to operate.</li> <li>Integrated control module LED display provides indicated error code.</li> <li>ComfortNet™ thermostat "Call for Service" icon illuminated.</li> <li>ComfortNet™ thermostat scrolls "Check Air Handler" message.</li> </ul> | b4 | <ul style="list-style-type: none"> <li>Circulator blower motor senses a loss rotor control.</li> <li>Circulator blower motor senses high current.</li> </ul> | MOTOR TRIPS    | b4                           | <ul style="list-style-type: none"> <li>Abnormal motor loading, sudden change in speed or torque, sudden blockage of air handler blower coil air inlet or outlet.</li> <li>High loading conditions, blocked filters, very restrictive ductwork, blockage of air handler blower coil air inlet or outlet.</li> </ul> | <ul style="list-style-type: none"> <li>Check filters, filter grilles/registers, duct system, and air handler blower coil air inlet/outlet for blockages.</li> </ul>   | <ul style="list-style-type: none"> <li>Turn power OFF prior to repair.</li> </ul>   |                    |  |                  |  |

# SERVICING

| 7-Segment LED Codes Characters W/W Alternates                    |  | ComfortNet™ Thermostat Only Message Code   |                      | Possible Cause    |  | Corrective Actions  |   | Notes & Cautions  |  |
|--|--|--|----------------------|-------------------|--|---|---|---|--|
| Symptoms of Abnormal Operation (Legacy & ComfortNet™ Thermostat) |  |  |                      | Fault Description |  | Message Code  |   |   |  |
| b5   | <ul style="list-style-type: none"> <li>Air handler blower fails to operate.</li> <li>Integrated control module LED display provides indicated error code.</li> <li>ComfortNet™ thermostat "Call for Service" icon illuminated.</li> <li>ComfortNet™ thermostat scrolls "Check Air Handler" message.</li> </ul> | <ul style="list-style-type: none"> <li>Circulator blower motor fails to start 10 consecutive times.</li> </ul>   | MTR<br>LCKD<br>ROTOR | b6                | <ul style="list-style-type: none"> <li>Obstruction in circulator blower housing.</li> <li>Seized circulator blower motor bearings.</li> <li>Failed circulator blower motor.</li> </ul> | <ul style="list-style-type: none"> <li>Check circulator blower for obstructions. Remove and repair/replace wheel/motor if necessary.</li> <li>Check circulator blower motor shaft rotation and motor. Replace motor if necessary.</li> </ul>  | <ul style="list-style-type: none"> <li>Turn power OFF prior to repair.</li> <li>Replace motor with correct replacement part.</li> <li>Replace wheel with correct replacement part.</li> </ul>   | <ul style="list-style-type: none"> <li>Turn power OFF prior to repair.</li> </ul> |  |
| b6   | <ul style="list-style-type: none"> <li>Air handler blower fails to operate.</li> <li>Integrated control module LED display provides indicated error code.</li> <li>ComfortNet™ thermostat "Call for Service" icon illuminated.</li> <li>ComfortNet™ thermostat scrolls "Check Air Handler" message.</li> </ul> | <ul style="list-style-type: none"> <li>Circulator blower motor shuts down for over or under voltage condition.</li> <li>Circulator blower motor shuts down due to over temperature condition on power module.</li> </ul> | MOTOR<br>VOLTS       | b6                | <ul style="list-style-type: none"> <li>High AC line voltage to air handler blower.</li> <li>Low AC line voltage to air handler blower.</li> <li>High ambient temperatures.</li> </ul>  | <ul style="list-style-type: none"> <li>Check power to air handler blower. Verify line voltage to blower is within the range specified on the air handler blower rating plate.</li> <li>See "Installation Instructions" for installation requirements.</li> </ul>  | <ul style="list-style-type: none"> <li>Turn power OFF prior to repair.</li> </ul>   | <ul style="list-style-type: none"> <li>Turn power OFF prior to repair.</li> </ul> |  |
| b7   | <ul style="list-style-type: none"> <li>Air handler blower fails to operate.</li> <li>Integrated control module LED display provides indicated error code.</li> <li>ComfortNet™ thermostat "Call for Service" icon illuminated.</li> <li>ComfortNet™ thermostat scrolls "Check Air Handler" message.</li> </ul> | <ul style="list-style-type: none"> <li>Circulator blower motor does not have enough information to operate properly. Motor fails to start 40 consecutive times.</li> </ul>   | MOTOR<br>PARAMS      | b7                | <ul style="list-style-type: none"> <li>Error with integrated control module.</li> <li>Motor has a locked rotor condition.</li> </ul>   | <ul style="list-style-type: none"> <li>Check integrated control module. Verify control is populated with correct shared data set. See data errors above for details.</li> <li>Check for locked rotor condition (see error code above for details).</li> </ul>   | <ul style="list-style-type: none"> <li>Turn power OFF prior to repair.</li> <li>Replace with correct replacement part(s).</li> <li>Use memory card for the specific model.</li> <li>Insert memory card BEFORE turning power ON.</li> <li>Memory card may be removed after data is loaded.</li> <li>Turn power off before removing memory card.</li> </ul> | <ul style="list-style-type: none"> <li>Turn power OFF prior to repair.</li> </ul> |  |
| b9   | <ul style="list-style-type: none"> <li>Air handler blower operates at reduced performance or operates on low stage when high stage is expected.</li> <li>Integrated control module LED display provides indicated error code.</li> </ul>   | <ul style="list-style-type: none"> <li>Airflow is lower than demanded.</li> </ul>  | LOW ID<br>AIRFLOW    | b9                | <ul style="list-style-type: none"> <li>Blocked filters.</li> <li>Restrictive ductwork.</li> <li>Undersized ductwork.</li> </ul>  | <ul style="list-style-type: none"> <li>Check filters for blockage. Clean filters or remove obstruction.</li> <li>Check ductwork for blockage. Remove obstruction. Verify all registers are fully open.</li> <li>Verify ductwork is appropriately sized for system. Resize/replace ductwork if necessary.</li> </ul> | <ul style="list-style-type: none"> <li>Turn power OFF prior to repair.</li> </ul>   | <ul style="list-style-type: none"> <li>Turn power OFF prior to repair.</li> </ul> |  |

# SERVICING

## S-17 CHECKING COMPRESSOR

### WARNING

Hermetic compressor electrical terminal venting can be dangerous. When insulating material which supports a hermetic compressor or electrical terminal suddenly disintegrates due to physical abuse or as a result of an electrical short between the terminal and the compressor housing, the terminal may be expelled, venting the vapor and liquid contents of the compressor housing and system.

If the compressor terminal PROTECTIVE COVER and gasket (if required) are not properly in place and secured, there is a remote possibility if a terminal vents, that the vaporous and liquid discharge can be ignited, spouting flames several feet, causing potentially severe or fatal injury to anyone in its path.

This discharge can be ignited external to the compressor if the terminal cover is not properly in place and if the discharge impinges on a sufficient heat source.

Ignition of the discharge can also occur at the venting terminal or inside the compressor, if there is sufficient contaminant air present in the system and an electrical arc occurs as the terminal vents.

Ignition cannot occur at the venting terminal without the presence of contaminant air, and cannot occur externally from the venting terminal without the presence of an external ignition source.

Therefore, proper evacuation of a hermetic system is essential at the time of manufacture and during servicing.

To reduce the possibility of external ignition, all open flame, electrical power, and other heat sources should be extinguished or turned off prior to servicing a system.

If the following test indicates shorted, grounded or open windings, see procedures S-19 for the next steps to be taken.

### S-17A RESISTANCE TEST

Each compressor is equipped with an internal overload.

The line break internal overload senses both motor amperage and winding temperature. High motor temperature or amperage heats the disc causing it to open, breaking the common circuit within the compressor on single phase units.

Heat generated within the compressor shell, usually due to recycling of the motor, high amperage or insufficient gas to cool the motor, is slow to dissipate. Allow at least three to four hours for it to cool and reset, then retest.

Fuse, circuit breaker, ground fault protective device, etc. has not tripped -

### WARNING

**HIGH VOLTAGE!**  
Disconnect ALL power before servicing or installing. Multiple power sources may be present. Failure to do so may cause property damage, personal injury or death.



1. Remove the leads from the compressor terminals.

### WARNING

See warnings S-17 before removing compressor terminal cover.

2. Using an ohmmeter, test continuity between terminals S-R, C-R, and C-S, on single phase units or terminals T2, T2 and T3, on 3 phase units.

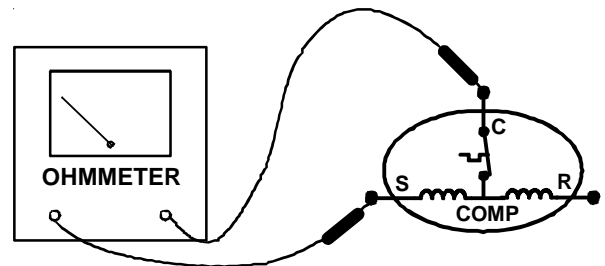

### TESTING COMPRESSOR WINDINGS

If either winding does not test continuous, replace the compressor.

**NOTE:** If an open compressor is indicated, allow ample time for the internal overload to reset before replacing compressor.

### S-17B GROUND TEST

If fuse, circuit breaker, ground fault protective device, etc., has tripped, this is a strong indication that an electrical problem exists and must be found and corrected. The circuit protective device rating must be checked, and its maximum rating should coincide with that marked on the equipment nameplate.

With the terminal protective cover in place, it is acceptable to replace the fuse or reset the circuit breaker ONE TIME ONLY to see if it was just a nuisance opening. If it opens again, DO NOT continue to reset.

**Disconnect all power to unit**, making sure that all power legs are open.

1. DO NOT remove protective terminal cover. Disconnect the three leads going to the compressor terminals at the nearest point to the compressor.
2. Identify the leads and using an ohmmeter on the R x 10,000 scale or the highest resistance scale on your ohmmeter check the resistance between each of the three leads separately to ground (such as an unpainted tube on the compressor).

## SERVICING

3. If a ground is indicated, then carefully remove the compressor terminal protective cover and inspect for loose leads or insulation breaks in the lead wires.
4. If no visual problems indicated, carefully remove the leads at the compressor terminals.
5. Carefully retest for ground, directly between compressor terminals and ground.
6. If ground is indicated, replace the compressor. The resistance reading should be infinity. If there is any reading on meter, there is some continuity to ground and compressor should be considered defective.

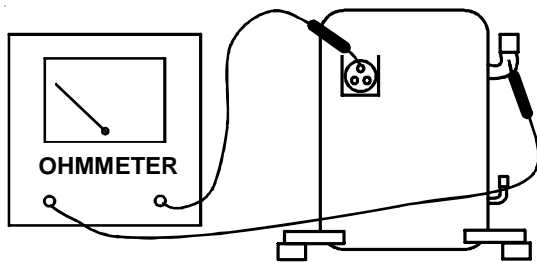

### WARNING

Damage can occur to the glass embedded terminals if the leads are not properly removed. This can result in terminal and hot oil discharging.

### S-17C UNLOADER TEST PROCEDURE

A nominal 24-volt direct current coil activates the internal unloader solenoid. The input control circuit voltage must be 18 to 28 volt ac. The coil power requirement is 20 VA. The external electrical connection is made with a molded plug assembly. This plug contains a full wave rectifier to supply direct current to the unloader coil.



UNLOADER SOLENOID  
(Molded Plug)

### Unloader Test Procedure

If it is suspected that the unloader is not working, the following methods may be used to verify operation.

1. Operate the system and measure compressor current. Cycle the unloader ON and OFF at 10 second intervals. The compressor amperage should go up or down at least 25 percent.
2. If step one does not give the expected results, shut unit off. Apply 18 to 28 volt ac to the unloader molded plug leads and listen for a click as the solenoid pulls in. Remove power and listen for another click as the unloader returns to its original position.
3. If clicks can't be heard, shut off power and remove the control circuit molded plug from the compressor and measure the unloader coil resistance. The resistance should be 32 to 60 ohms, depending on compressor temperature.
4. Next check the molded plug.
  - A. Voltage check: Apply control voltage to the plug wires (18 to 28 volt ac). The measured dc voltage at the female connectors in the plug should be around 15 to 27 vdc.
  - B. Resistance check: Measure the resistance from the end of one molded plug lead to either of the two female connectors in the plug. One of the connectors should read close to zero ohms while the other should read infinity. Repeat with other wire. The same female connector as before should read zero while the other connector again reads infinity. Reverse polarity on the ohmmeter leads and repeat. The female connector that read infinity previously should now read close to zero ohms.
  - C. Replace plug if either of these test methods doesn't show the desired results.

### S-17D OPERATION TEST

If the voltage, capacitor, overload and motor winding test fail to show the cause for failure:



### WARNING

**HIGH VOLTAGE!**  
Disconnect ALL power before servicing or installing. Multiple power sources may be present. Failure to do so may cause property damage, personal injury or death.



1. Remove unit wiring from disconnect switch and wire a test cord to the disconnect switch.
- NOTE:** The wire size of the test cord must equal the line wire size and the fuse must be of the proper size and type.
2. With the protective terminal cover in place, use the three leads to the compressor terminals that were disconnected at the nearest point to the compressor and connect the common, start and run clips to the respective leads.
  3. Connect good capacitors of the right MFD and voltage rating into the circuit as shown.



## SERVICING

4. With power ON, close the switch.

 **WARNING**  
Line Voltage now present.

- A. If the compressor starts and continues to run, the cause for failure is somewhere else in the system.
- B. If the compressor fails to start - replace.

### COPELAND COMPRESSOR

|      |       |                  |       |
|------|-------|------------------|-------|
| 03   | A     | 12345            | L     |
|      |       |                  |       |
| YEAR | MONTH | SERIAL<br>NUMBER | PLANT |

### S-17E CHECKING 3-PHASE SCROLL COMPRESSOR ROTATION

Verify the proper rotation of Copeland scroll compressors as follows:

**NOTE:** The compressor may run backwards (noisy operation) for 1 or 2 seconds at shutdown. This is normal and does not harm the compressor.

1. Install gauges and verify that the suction pressure drops while the discharge pressure increases.
2. Listen for normal compressor sound levels. Reverse rotation results in elevated or unusual sound levels.
3. Reverse rotation will result in substantially reduced amp draw from tabulated values.

To correct improper rotation, switch any two power supply leads at the outdoor unit contactor.

The 3-phase scroll compressors are direction of rotation sensitive. They will rotate in either direction depending on the phasing of the power. There is no negative impact on durability caused by operating 3-phase compressors in reversed rotation. The compressor's internal protector will trip, de-energizing the compressor. Continued operation of 3-phase scroll compressors with the rotation reversed will contribute to compressor failure. All 3-phase scroll compressors should be checked for correct phase rotation.

### S-18 TESTING CRANKCASE HEATER (OPTIONAL ITEM)

*The crankcase heater must be energized a minimum of four (4) hours before the condensing unit is operated.*

Crankcase heaters are used to prevent migration or accumulation of refrigerant in the compressor crankcase during the off cycles and prevents liquid slugging or oil pumping on start up.

*A crankcase heater will not prevent compressor damage due to a floodback or over charge condition.*

 **WARNING**  
Disconnect ALL power before servicing.

1. Disconnect the heater lead in wires.
2. Using an ohmmeter, check heater continuity - should test continuous. If not, replace.

**NOTE:** The positive temperature coefficient crankcase heater is a 40 watt 265 voltage heater. The cool resistance of the heater will be approximately 1800 ohms. The resistance will become greater as the temperature of the compressor shell increases.

### S-21 CHECKING REVERSING VALVE AND SOLENOID

Occasionally the reversing valve may stick in the heating or cooling position or in the mid-position.

When stuck in the mid-position, part of the discharge gas from the compressor is directed back to the suction side, resulting in excessively high suction pressure. An increase in the suction line temperature through the reversing valve can also be measured. Check operation of the valve by starting the system and switching the operation from COOLING to HEATING cycle.

If the valve fails to change its position, test the voltage (24V) at the valve coil terminals, while the system is on the COOLING cycle.

**All heat pumps and ComfortNet™ heat pumps wired in legacy** - If no voltage is registered at the coil terminals, check the operation of the thermostat and the continuity of the connecting wiring from the "O" terminal of the thermostat to the unit.

**ComfortNet heat pumps only** - Check voltage (24VAC) at the non-insulated terminal E22 on the UC control board (RVS on silkscreen) and "C" terminal on the 7-pin or 4-pin connector on the UC control

If voltage is registered at the coil, tap the valve body lightly while switching the system from HEATING to COOLING, etc. If this fails to cause the valve to switch positions, remove the coil connector cap and test the continuity of the reversing valve solenoid coil. If the coil does not test continuous - replace it.

If the coil test continuous and 24 volts is present at the coil terminals, the valve is inoperative - replace it.

### S-24 TESTING DEFROST CONTROL

#### LEGACY MODELS:

To check the defrost control for proper sequencing, proceed as follows: With power ON; unit not running.

1. Jumper defrost thermostat by placing a jumper wire across the terminals "DFT" and "R"/"R-DFT" at defrost control board.
2. Connect jumper across test pins on defrost control board.

# SERVICING

- Set thermostat to call for heating. System should go into defrost within 21 seconds.
- Immediately remove jumper from test pins.
- Using VOM check for voltage across terminals "C & O". Meter should read 24 volts.
- Using VOM check for voltage across fan terminals DF1 and DF2 on the board. You should read line voltage (208-230 VAC) indicating the relay is open in the defrost mode.
- Using VOM check for voltage across "W"/"W2" & "C" terminals on the board. You should read 24 volts.
- If not as above, replace control board.
- Set thermostat to off position and disconnect power before removing any jumpers or wires.

NOTE: Remove jumper across defrost thermostat before returning system to service.

## COMFORTNET™ UNITS:

To check the defrost control for proper sequencing, proceed as follows: With power ON; unit not running.

- Set thermostat to call for heating.
- Press **TEST** and **RECALL** buttons simultaneously for approximately 3 seconds, then release them. System should go into defrost immediately.
- Using VOM check for voltage across terminals "C & O". Meter should read 24 volts (skip this step if system a fully communicating system)
- Visually inspect to see that the frost is gradually melting on the coil and the compressor is running.
- Using VOM check for voltage across "W2 & C" terminals on the board. You should read 24 volts.
- If not as above, replace control board.
- Set thermostat to off position and disconnect power before removing any jumpers or wires.

## S-25 TESTING DEFROST THERMOSTAT

### LEGACY MODELS ONLY:

- Install a thermocouple type temperature test lead on the tube adjacent to the defrost control. Insulate the lead point of contact.
- Check the temperature at which the control closes its contacts by lowering the temperature of the control. Part # 0130M00009P which is used on 2 and 2.5 ton units should close at 34°F ± 5°F. Part # 0130M00001P or B1370803 which is used on 3 thru 5 ton units should close at 31°F ± 3°F.
- Check the temperature at which the control closes its contacts by lowering the temperature of the control. Part # 0130M000085, which is used on units with 5 mm coils, should close at 30°F ± 5°F.
- Check the temperature at which the control opens its contacts by raising the temperature of the control. Part #0130M00009P which is used on 2 and 2.5 ton units should open at 60°F ± 5°F. Part # 0130M00001P or

B1370803 which is used on 3 thru 5 ton units should open at 75°F ± 6°F.

- Check the temperature at which the control opens its contacts by raising the temperature of the control. Part # 0130M000085, which is used on units with 5 mm coils, should open at 60°F ± 5°F.
- If not as above, replace control.

## S-26 TESTING TEMPERATURE SENSORS (COMFORTNET READY MODELS ONLY)

The ASXC and DSXC ComfortNet ready air conditioner models are factory equipped with an outdoor air temperature (OAT) sensor. The OAT sensor allows the outdoor air temperature to be displayed on the CTK0\* thermostat when used with the ASXC and DSXC models.

The ASZC and DSZC ComfortNet ready heat pump models are equipped with both an outdoor air temperature (OAT) sensor and an outdoor coil temperature (OCT) sensor. The OAT provides the balance point temperature in heat pump systems (air handler w/electric heat + heat pump) and dual fuel systems. The OCT sensor is provides the outdoor coil temperature and is used in determining defrost cycles.

To check either the outdoor air or outdoor coil temperature sensors:



**WARNING**

**HIGH VOLTAGE!**  
Disconnect ALL power before servicing or installing. Multiple power sources may be present. Failure to do so may cause property damage, personal injury or death.



- Disconnect power to the air conditioner or heat pump.
- Disconnect the sensor from the unitary (UC) control.
- Connect an ohmmeter across the sensor terminals. The ohmmeter should read be 10kΩ, +/-10%, at 75°F. Replace the sensor if the sensor is open, shorted, or outside the valid resistance range.

| Ohm Reading of Communicating Outdoor Unit Sensors |         |       |        |       |        |       |       |       |       |
|---|---------|-------|--------|-------|--------|-------|-------|-------|-------|
| T, °F   | RW@T    | T, °F | RW@T   | T, °F | RW@T   | T, °F | RW@T  | T, °F | RW@T  |
| -40   | 336,000 | 5     | 72,940 | 50    | 19,903 | 95    | 6,530 | 140   | 2,488 |
| -31   | 242,700 | 14    | 55,319 | 59    | 15,714 | 104   | 5,327 | 149   | 2,083 |
| -22   | 177,000 | 23    | 42,324 | 68    | 12,493 | 113   | 4,370 | 158   | 1,752 |
| -13   | 130,400 | 32    | 32,654 | 77    | 10,000 | 122   | 3,603 | 167   | 1,480 |
| -4  | 97,060  | 41    | 25,396 | 86    | 8,056  | 134   | 2,986 | 176   | 1,255 |

## S-40 MBR/AR\*F ELECTRONIC BLOWER TIME DELAY RELAY

The MBR/AR\*F contains an Electronic Blower Time Delay Relay board, B1370735. This board provides on/off time delays for the blower motor in cooling and heat pump heating demands when "G" is energized.

# SERVICING

During a cooling or heat pump heating demand, 24Vac is supplied to terminal “G” of the EBTDR to turn on the blower motor. The EBTDR initiates a 7 second delay on and then energizes it’s onboard relay. The relay on the EBTDR board closes it’s normally open contacts and supplies power to the blower motor. When the “G” input is removed, the EBTDR initiates a 65 second delay off. When the 65 seconds delay expires the onboard relay is de-energized and it’s contacts open and remove power from the blower motor.

During an electric heat only demand, “W1” is energized but “G” is not. The blower motor is connected to the normally closed contacts of the relay on the EBTDR board. The other side of this set of contacts is connected to the heat sequencer on the heater assembly that provides power to the first heater element. When “W1” is energized, the sequencer will close it’s contacts within 10 to 20 seconds to supply power to the first heater element and to the blower motor through the normally closed contacts on the relay on the EBTDR. When the “W1” demand is removed, the sequencer opens it contacts within 30 to 70 seconds and removes power from the heater element and the blower motor.

The EBTDR also contains a speedup terminal to reduce the delays during troubleshooting of the unit. When this terminal is shorted to the common terminal, “C”, on the EBTDR board, the delay ON time is reduced to 3 seconds and the delay OFF time is reduced to 5 second.

Two additional terminals, M1 and M2, are on the EBTDR board. These terminals are used to connect the unused leads from the blower motor and have no affect on the board’s operation.

## S-40A AVPTC/MBVC ELECTRONIC BLOWER/ HEATER CONTROL

### Description

The AVPTC and MBVC models utilize an electronic control that provides ECM blower motor control and control of up to two electric heat sequencers. The control has thermostat inputs for up to two stages of cooling, two stages of electric heat, reversing valve, and dehumidification. Control input is 24VAC.

All dipswitches necessary to setup cooling, heat pump, and electric heat airflow are fully integrated into the control. Dehumidification is enabled/disabled via an on-board dipswitch.

### Features

The new air handler control includes advanced diagnostic features with fault recall, estimated CFM display via on-board LED, and ComfortNet™ ready. Diagnostics includes heater kit selection diagnostics, open fuse, internal control fault, data errors, and blower motor faults. Data errors are not included in the fault recall list. Diagnostic error codes are displayed on a single red LED.

The estimated CFM is displayed on an on-board green LED. The LED flashes once for each 100 CFM.



The AVPTC/MBVC air handlers may be used in a fully communicating ComfortNet system when matched with a compatible outdoor unit and the CTK0\* thermostat. A fully communicating system offers advanced setup and diagnostic features.

### Basic Operation

The air handler control receives thermostat inputs either from a standard 24VAC thermostat or the CTK0\* ComfortNet thermostat. For cooling and heat pump operation, the control operates the variable speed blower motor at the demand as determined from the thermostat input(s). If a demand for electric heat is received, the control will provide a 24VAC output for up to two electric heat sequencers.

### Troubleshooting

#### Motor Control Circuits



**WARNING**  
**HIGH VOLTAGE!**  
Disconnect ALL power before servicing or installing. Multiple power sources may be present. Failure to do so may cause property damage, personal injury or death.

1. Turn on power to air handler or modular.

**WARNING**  
Line Voltage now present.

2. Check voltage between pins 1 and 4 at the 4-wire motor connector on the control board. Voltage should be between 9 and 15 VDC. Replace control if voltage is not as specified.

#### Electric Heat Sequencer Outputs

**WARNING**  
**HIGH VOLTAGE!**  
Disconnect ALL power before servicing or installing. Multiple power sources may be present. Failure to do so may cause property damage, personal injury or death.

1. Turn on power to air handler or modular blower.

**WARNING**  
Line Voltage now present.

2. Disconnect the 4-circuit harness connecting the control to the electric heater kit.

## SERVICING

3. Provide a thermostat demand for low stage auxiliary heat (W1). Measure the voltage between circuits 1 and 3 at the on-board electric heat connector. Voltage should measure 24VAC. Replace control if no voltage is present.

**NOTE:** Allow for any built-in time delays before making voltage measurements. Any electric heater faults that are present may prevent the heater output from energizing. Verify that no heater faults are present before making voltage measurements.

4. Provide a thermostat demand for high stage auxiliary heat (W1 + W2). Measure the voltage between circuits 1 and 3 at the on-board electric heat connector. Measure the voltage between circuits 2 and 3 at the on-board electric heat connector. Voltage should measure 24VAC. Replace control if no voltage is present.

*Communications (Applies only to Systems with Compatible ComfortNet™ Outdoor Unit and CTK0\*Thermostat)*

The integrated air handler control has some on-board tools that may be used to troubleshoot the network. These tools are: red communications LED, green receive (Rx) LED, and learn button. These are described below

- a. Red communications LED – Indicates the status of the network. Refer to the Network Troubleshooting Chart for the LED status and the corresponding potential problem.
- b. Green receive LED – Indicates network traffic. Refer to the Network Troubleshooting Chart for the LED status and the corresponding potential problem.
- c. Learn button – Used to reset the network. Depress the button for approximately 2 seconds to reset the network.

Voltages between the two data lines and between each data line and common may be used to determine if the network is operating properly.

Do the following to measure the voltages on the communications data lines.



### WARNING

Line Voltage now present.

1. Remove communicating wires from outdoor board and thermostat and check bias voltage at the low voltage connections on the air handler control board.
2. DC voltage from C to data 1 should read approximately 1.96vdc.
3. DC voltage from C to data 2 should read approximately 1.36vdc.
4. Difference in voltage should be .6vdc.
5. Reconnect communicating wires from outdoor board and check bias voltage.
6. If voltages do not match the original readings bias switches on outdoor board need to be changed to “off” from the factory setting of “on”.
7. Remove plastic film covering switches with screw driver or knife.
8. Turn both Bias switches to the off position.
9. Recheck DC voltage at indoor unit with wires from outdoor board connected.
10. DC voltage from C to data 1 should read approximately 1.96vdc.
11. DC voltage from C to data 2 should read approximately 1.36vdc.
12. Difference in bias voltage should again be .6vdc.

# SERVICING

## NETWORK TROUBLESHOOTING CHART

| LED                    | LED Status     | Indication  | Possible Causes   | Corrective Action(s)   | Notes & Cautions  |
|------------------------|----------------|---|---|--|---|
| Red Communications LED | Off            | <ul style="list-style-type: none"> <li>Normal condition</li> </ul>                      | <ul style="list-style-type: none"> <li>None</li> </ul>  | <ul style="list-style-type: none"> <li>None</li> </ul>   | <ul style="list-style-type: none"> <li>None</li> </ul>  |
|                        | 1 Flash        | <ul style="list-style-type: none"> <li>Communication Failure</li> </ul>                 | <ul style="list-style-type: none"> <li>Communication Failure</li> </ul>   | <ul style="list-style-type: none"> <li>Depress Learn Button</li> </ul>   | <ul style="list-style-type: none"> <li>Depress once quickly for a power-up reset</li> <li>Depress and hold for 2 seconds for an out-of-box reset</li> </ul>                                     |
|                        | 2 Flashes      | <ul style="list-style-type: none"> <li>Out-of-box reset</li> </ul>                      | <ul style="list-style-type: none"> <li>Control power up</li> <li>Learn button depressed</li> </ul>  | <ul style="list-style-type: none"> <li>None</li> </ul>   | <ul style="list-style-type: none"> <li>None</li> </ul>  |
| Green Receive LED      | Off            | <ul style="list-style-type: none"> <li>No power</li> <li>Communication error</li> </ul> | <ul style="list-style-type: none"> <li>No power to modular blower</li> <li>Open fuse</li> <li>Communication error</li> </ul>  | <ul style="list-style-type: none"> <li>Check fuses and circuit breakers; replace /reset</li> <li>Replace blown fuse</li> <li>Check for shorts in low voltage wiring in modular blower/system</li> <li>Reset network by depressing learn button</li> <li>Check data 1/ data 2 voltages</li> </ul> | <ul style="list-style-type: none"> <li>Turn power OFF prior to repair</li> </ul>  |
|                        | 1 Steady Flash | <ul style="list-style-type: none"> <li>No network found</li> </ul>                      | <ul style="list-style-type: none"> <li>Broken/ disconnected data wire(s)</li> <li>Modular blower is installed as a legacy/ traditional system</li> </ul>  | <ul style="list-style-type: none"> <li>Check communications wiring (data 1/ data 2 wires)</li> <li>Check wire connections at terminal block</li> <li>Verify modular blower installation type (legacy/ traditional or communicating)</li> <li>Check data 1/ data 2 voltages</li> </ul>            | <ul style="list-style-type: none"> <li>Turn power OFF prior to repair</li> <li>Verify wires at terminal blocks are securely twisted together prior to inserting in to terminal block</li> </ul> |
|                        | Rapid Flashing | <ul style="list-style-type: none"> <li>Normal network traffic</li> </ul>                | <ul style="list-style-type: none"> <li>Control is "talking" on network as expected</li> </ul>   | <ul style="list-style-type: none"> <li>None</li> </ul>   | <ul style="list-style-type: none"> <li>None</li> </ul>  |
|                        | On Solid       | <ul style="list-style-type: none"> <li>Data 1/ Data 2 miss-wire</li> </ul>              | <ul style="list-style-type: none"> <li>Data 1 and data 2 wires reversed at modular blower thermostat, or CT™ compatible outdoor AC/HP</li> <li>Short between data 1 and data 2 wires</li> <li>Short between data 1 or data 2 wires and R (24 VAC) or C (24 VAC common)</li> </ul> | <ul style="list-style-type: none"> <li>Check communications wiring (data 1/ data 2 wires)</li> <li>Check wire connections at terminal block</li> <li>Check data 1/ data 2 voltages</li> </ul>  | <ul style="list-style-type: none"> <li>Turn power OFF prior to repair</li> <li>Verify wires at terminal blocks are securely twisted together prior to inserting in to terminal block</li> </ul> |

# SERVICING

## SEQUENCE OF OPERATION

This document covers the basic sequence of operation for a typical application with a mercury bulb thermostat. When a digital/electronic thermostat is used, the on/off staging of the auxiliary heat will vary. **Refer to the installation instructions and wiring diagrams provided with the MBR/AR\*F for specific wiring connections and system configuration.**

### ***MBR/AR\*F WITH SINGLE STAGE CONDENSERS***

#### **1.0 Cooling Operation**

- 1.1 On a demand for cooling, the room thermostat energizes “G” and “Y” and 24Vac is supplied to “Y” at the condensing unit and the “G” terminal on the EBTDR board.
- 1.2 The compressor and condenser fan are turned on and after a 7 second on delay, the relay on the EBTDR board is energized and the blower motor starts.
- 1.3 When the cooling demand “Y” is satisfied, the room thermostat removes the 24Vac from “G” and “Y”.
- 1.4 The compressor and condenser fan are turned off and after a 65 second delay off, the relay on the EBTDR board is de-energized and the blower is turned off.

#### **2.0 Heating Operation**

- 2.1 On a demand for heat, the room thermostat energizes “W1” and 24Vac is supplied to heat sequencer, HR1, on the heater assembly.
- 2.2 The contacts M1 and M2 will close within 10 to 20 seconds and turn on heater element #1. The normally closed contacts on the EBTDR are also connected to terminal M1. When M1 and M2 close, the blower motor will be energized thru the normally closed contacts on the EBTDR board. At the same time, if the heater assembly contains a second heater element, HR1 will contain a second set of contacts, M3 and M4, which will close to turn on heater element #2.

**Note:** If more than two heater elements are on the heater assembly, it will contain a second heat sequencer, HR2, which will control the 3<sup>rd</sup> and 4<sup>th</sup> heater elements if available. If the first stage heat demand, “W1” cannot be satisfied by the heat pump, the temperature indoors will continue to drop. The room thermostat will then energize “W2” and 24Vac will be supplied to HR2 on the heater assembly. When the “W2” demand is satisfied, the room thermostat will remove the 24Vac from HR2. The contacts on HR2 will open between 30 to 70 seconds and heater elements #3 and #4 will be turned off. **On most digital/electronic thermostats, “W2” will remain energized until the first stage demand “W1” is satisfied and then the “W1” and “W2” demands will be removed.**

- 2.3 When the “W1” heat demand is satisfied, the room thermostat will remove the 24Vac from HR1. Both set of contacts on the relay opens within 30 to 70 seconds and turn off the heater element(s) and the blower motor.

### ***MBR/AR\*F WITH SINGLE STAGE HEAT PUMPS***

#### **3.0 Cooling Operation**

On heat pump units, when the room thermostat set to the cooling mode, 24Vac is supplied to “O” which energizes the reversing valve. As long as the thermostat is set for cooling, the reversing valve will be in the energized position for cooling.

- 3.1 On a demand for cooling, the room thermostat energizes “G” and “Y” and 24Vac is supplied to “Y” at the heat pump and the “G” terminal on the EBTDR board.
- 3.2 The heat pump turned on in the cooling mode and after a 7 second on delay, the relay on the EBTDR board is energized and the blower motor starts.
- 3.3 When the cooling demand is satisfied, the room thermostat removes the 24Vac from “G” and “Y”.
- 3.4 The heat pump is turned off and after a 65 second delay off, the relay on the EBTDR board is de-energized and the blower motor is turned off.

#### **4.0 Heating Operation**

On heat pump units, when the room thermostat set to the heating mode, the reversing valve is not energized. As long as the thermostat is set for heating, the reversing valve will be in the de-energized position for heating except during a defrost cycle. Some installations may use one or more outdoor thermostats to restrict the amount of electric heat that is available above a preset ambient temperature. Use of optional controls such as these can change the operation of the electric heaters during the heating mode. This sequence of operation does not cover those applications.

- 4.1 On a demand for first stage heat with heat pump units, the room thermostat energizes “G” and “Y” and 24Vac is supplied to “Y” at the heat pump unit and the “G” terminal on the EBTDR board. The heat pump is turned on in the heating mode and the blower motor starts after a 7 second on delay.
- 4.2 If the first stage heat demand cannot be satisfied by the heat pump, the temperature indoors will continue to drop. The room thermostat will then energize terminal “W2” for second stage heat and 24Vac will be supplied to heat sequencer HR1 on the heater assembly.
- 4.3 HR1 contacts M1 and M2 will close within 10 to 20 seconds and turn on heater element #1. At the same time, if the heater assembly contains a second heater element, HR1 will contain a second set of contacts, M3 and M4, which will close and turn on heater element #2. The blower motor is already on as a result of terminal “G” on the EBTDR board being energized for the first stage heat demand.

**Note:** If more than two heater elements are on the heater assembly, it will contain a second heat sequencer, HR2, which will control the 3<sup>rd</sup> and 4<sup>th</sup> heater elements if available. If the second stage heat demand, “W2” cannot be satisfied by the heat pump, the temperature indoors will continue to drop. The room thermostat will then energize “W3” and 24Vac will be supplied to HR2 on the heater assembly. When

# SERVICING

the “W3” demand is satisfied, the room thermostat will remove the 24Vac from HR2. The contacts on HR2 will open between 30 to 70 seconds and heater elements #3 and #4 will be turned off. **On most digital/electronic thermostats, “W3” will remain energized until the first stage heat demand “Y” is satisfied and then the “G”, “Y”, “W2” and “W3” demands will be removed.**

**4.4** As the temperature indoors increase, it will reach a point where the second stage heat demand, “W2”, is satisfied. When this happens, the room thermostat will remove the 24Vac from the coil of HR1. The contacts on HR1 will open between 30 to 70 seconds and turn off both heater element(s). The heat pump remains on along with the blower motor because the “Y” demand for first stage heat will still be present.

**4.5** When the first stage heat demand “Y” is satisfied, the room thermostat will remove the 24Vac from “G” and “Y”. The heat pump is turned off and the blower motor turns off after a 65 second off delay.

## **5.0 Defrost Operation**

On heat pump units, when the room thermostat is set to the heating mode, the reversing valve is not energized. As long as the thermostat is set for heating, the reversing valve will be in the de-energized position for heating except during a defrost cycle.

**5.1** The heat pump will be on and operating in the heating mode as described the Heating Operation in section 4.

**5.2** The defrost control in the heat pump unit checks to see if a defrost is needed every 30, 60 or 90 minutes of heat pump operation depending on the selectable setting by monitoring the state of the defrost thermostat attached to the outdoor coil.

**5.3** If the temperature of the outdoor coil is low enough to cause the defrost thermostat to be closed when the defrost board checks it, the board will initiate a defrost cycle.

**5.4** When a defrost cycle is initiated, the contacts of the HVDR relay on the defrost board open and turns off the outdoor fan. The contacts of the LVDR relay on the defrost board closes and supplies 24Vac to “O” and “W2”. The reversing valve is energized and the contact on HR1 close and turns on the electric heater(s). The unit will continue to run in this mode until the defrost cycle is completed.

a. For models with defrost control PCBDM133 or PCBDM160, a 30 second compressor delay at defrost initiation/termination is optional. As shipped from the factory, the control is set for the delay (“DLY”), which will turn the compressor off for 30 seconds while the reversing valve shifts to/from the cooling mode position. To bypass the delay, which typically reduces sound levels during defrost mode, change the pin settings from “DLY” to “NORM”.

**5.5** When the temperature of the outdoor coil rises high enough to causes the defrost thermostat to open, the defrost cycle will be terminated. If at the end of the programmed 10 minute override time the defrost thermostat is still closed, the defrost board will automatically terminate the defrost cycle.

**5.6** When the defrost cycle is terminated, the contacts of the HVDR relay will close to start the outdoor fan and the contacts of the LVDR relay will open and turn off the reversing valve and electric heater(s). The unit will now be back in a normal heating mode with a heat pump demand for heating as described in the Heating Operation in section 4. See section 5.4a.

## **MBE/AEPF WITH GSX, SSX, ASX, DSX, VSX**

### **MBE ELECTRONIC BLOWER TIME DELAY RELAY**

#### **AEPF AIR HANDLER**

## **SEQUENCE OF OPERATION**

This document covers the basic sequence of operation for a typical application with a mercury bulb thermostat. When a digital/electronic thermostat is used, the on/off staging of the auxiliary heat will vary. **Refer to the installation instructions and wiring diagrams provided with the MBE/AEPF for specific wiring connections, dip switch settings and system configuration.**

## **MBE/AEPF WITH SINGLE STAGE GSX, ASX, SSX, and VSX CONDENSERS**

When used with a single stage GSX, SSX, ASX, and VSX condensers, dip switch #4 must be set to the on position on the VSTB inside the MBE/AEPF. The “Y” output from the indoor thermostat must be connected to the yellow wire labeled “Y/Y2” inside the wire bundle marked “Thermostat” and the yellow wire labeled “Y/Y2” inside the wire bundle marked “Outdoor Unit” must be connected to “Y” at the condenser. **The orange jumper wire from terminal “Y1” to terminal “O” on the VSTB inside the MBE/AEPF must remain connected.**

## **1.0 Cooling Operation**

**1.1** On a demand for cooling, the room thermostat energizes “G” and “Y” and 24Vac is supplied to “G” and “Y/Y2” of the MBE/AEPF unit. The VSTB inside the MBE/AEPF will turn on the blower motor and the motor will ramp up to the speed programmed in the motor based on the settings for dip switch 5 and 6. The VSTB will supply 24Vac to “Y” at the condenser and the compressor and condenser are turned on.

**1.2** When the cooling demand is satisfied, the room thermostat removes the 24Vac from “G” and “Y”. The MBE/AEPF removes the 24Vac from “Y” at the condenser and the compressor and condenser fan are turned off. The blower motor will ramp down to a complete stop based on the time and rate programmed in the motor.

## **2.0 Heating Operation**

**2.1** On a demand for heat, the room thermostat energizes “W1” and 24Vac is supplied to terminal “E/W1” of the VSTB inside the MBE/AEPF unit. The VSTB will turn on the blower motor and the motor will ramp up to the speed programmed in the motor based on the settings for dip switch 1 and 2. The VSTB will supply 24Vac to heat sequencer HR1 on the electric heater assembly.

**2.2** HR1 contacts M1 and M2 will close within 10 to 20 seconds and turn on heater element #1. At the same

# SERVICING

time, if the heater assembly contains a second heater element, HR1 will contain a second set of contacts, M3 and M4, which will close and turn on heater element #2.

**Note:** If more than two heater elements are on the heater assembly, it will contain a second heat sequencer, HR2, which will control the 3<sup>rd</sup> and 4<sup>th</sup> heater elements if available. **For the 3<sup>rd</sup> and 4<sup>th</sup> heater elements to operate on a second stage heat demand, the PJ4 jumper on the VSTB inside the MBE/AEPF must be cut.** With the PJ4 jumper cut, the VSTB will run the blower motor on low speed on a “W1” only demand. If the first stage heat demand, “W1” cannot be satisfied by the heat pump, the temperature indoors will continue to drop. The room thermostat will then energize “W2” and 24Vac will be supplied to HR2 on the heater assembly and the blower motor will change to high speed. When the “W2” demand is satisfied, the room thermostat will remove the 24Vac from “W2” and the VSTB will remove the 24Vac from HR2. The contacts on HR2 will open between 30 to 70 seconds and heater elements #3 and #4 will be turned off and the blower motor will change to low speed. **On most digital/electronic thermostats, “W2” will remain energized until the first stage demand “W1” is satisfied and then the “W1” and “W2” demands will be removed.**

**2.3** When the “W1” heat demand is satisfied, the room thermostat will remove the 24Vac from “E/W1” and the VSTB removes the 24Vac from HR1. The contacts on HR1 will open between 30 to 70 seconds and turn off the heater element(s) and the blower motor ramps down to a complete stop.

## **MBE/AEPF WITH SINGLE STAGE**

### **GSZ, SSZ, ASZ, and VSZ HEAT PUMPS**

When used with a single stage GSZ, SSZ, ASZ, or VSZ heat pumps, dip switch #4 must be set to the ON position on the VSTB inside the MBE. The “Y” output from the indoor thermostat must be connected to the yellow wire labeled “Y/Y2” inside the wire bundle marked “Thermostat” and the yellow wire labeled “Y/Y2” inside the wire bundle marked “Outdoor Unit” must be connected to “Y” at the heat pump. **The orange jumper wire from terminal “Y1” to terminal “O” on the VSTB inside the MBE/AEPF must be removed.**

## **3.0 COOLING OPERATION**

On heat pump units, when the room thermostat is set to the cooling mode, 24Vac is supplied to terminal “O” of the VSTB inside the MBE/AEPF unit. The VSTB will supply 24Vac to “O” at the heat pump to energize the reversing valve. As long as the thermostat is set for cooling, the reversing valve will be in the energized position for cooling.

**3.1** On a demand for cooling, the room thermostat energizes “G” and “Y” and 24Vac is supplied to terminals “G” and “Y/Y2” of the MBE/AEPF unit. The VSTB will turn on the blower motor and the motor will ramp up to the speed programmed in the motor based on the settings of dip switch 5 and 6. The VSTB will supply 24Vac to “Y” at the heat pump.

**3.2** The heat pump is turned on in the cooling mode.

**3.3** When the cooling demand is satisfied, the room thermostat removes the 24Vac from “G” and “Y/Y2” of the MBE/AEPF and the VSTB removes the 24Vac from “Y” at the heat pump. The heat pump is turned off and the blower motor will ramp down to a complete stop based on the time and rate programmed in the motor.

## **4.0 Heating Operation**

On heat pump units, when the room thermostat is set to the heating mode, the reversing valve is not energized. As long as the thermostat is set for heating, the reversing valve will be in the de-energized position for heating except during a defrost cycle. Some installations may use one or more outdoor thermostats to restrict the amount of electric heat that is available above a preset ambient temperature. Use of optional controls such as these can change the operation of the electric heaters during the heating mode. This sequence of operation does not cover those applications.

**4.1** On a demand for first stage heat with heat pump units, the room thermostat energizes “Y” and “G” and 24Vac is supplied to “G” and “Y/Y2” of the MBE/AEPF. The VSTB will turn on the blower motor and the motor will ramp up to the speed programmed in the motor based on the settings of dip switch 1 and 2. The VSTB will supply 24Vac to “Y” at the heat pump and the heat pump is turned on in the heating mode.

**4.2** If the first stage heat demand cannot be satisfied by the heat pump, the temperature indoors will continue to drop. The room thermostat will then energize terminal “W2” for second stage heat and 24Vac will be supplied to “E/W1” of the MBE/AEPF. The VSTB will supply 24Vac to heat sequencer, HR1, on the electric heater assembly.

**4.3** HR1 contacts M1 and M2 will close within 10 to 20 seconds and turn on heater element #1. At the same time, if the heater assembly contains a second heater element, HR1 will contain a second set of contacts, M3 and M4, which will close to turn on heater element #2.

**Note:** If more than two heater elements are on the heater assembly, it will contain a second heat sequencer, HR2, which will control the 3<sup>rd</sup> and 4<sup>th</sup> heater elements if available. **For the 3<sup>rd</sup> and 4<sup>th</sup> heater elements to operate on a third stage heat demand, the PJ4 jumper on the VSTB inside the MBE/AEPF must be cut.** If the second stage heat demand, “W2”, cannot be satisfied by the heat pump, the temperature indoors will continue to drop. The room thermostat will then energize “W3” and 24Vac will be supplied to “W/W2” of the MBE/AEPF. The VSTB will supply 24Vac to HR2 on the electric heater assembly. When the “W3” demand is satisfied, the room thermostat will remove the 24Vac from “W/W2” of the MBE/AEPF. The contacts on HR2 will open between 30 to 70 seconds and heater elements #3 and #4 will be turned off. **On most digital/electronic thermostats, “W3” will remain energized until the first stage demand “Y” is satisfied and then the “G”, “Y”, “W2” and “W3” demands will be removed.**



# SERVICING

**4.4** As the temperature indoors increase, it will reach a point where the second stage heat demand, “W2”, is satisfied. When this happens, the room thermostat will remove the 24Vac from “E/W1” of the MBE/AEPF. The contacts on HR1 will open between 30 to 70 seconds and turn off both heater element(s). The heat pump remains on along with the blower motor because the “Y” demand for first stage heat will still be present.

**4.5** When the first stage heat demand “Y” is satisfied, the room thermostat will remove the 24Vac from “G” and “Y/Y2” of the MBE/AEPF. The VSTB removes the 24Vac from “Y” at the heat pump and the heat pump is turned off. The blower motor will ramp down to a complete stop based on the time and rate programmed in the motor control.

## 5.0 DEFROST OPERATION

On heat pump units, when the room thermostat is set to the heating mode, the reversing valve is not energized. As long as the thermostat is set for heating, the reversing valve will be in the de-energized position for heating except during a defrost cycle.

5.1 The heat pump will be on and operating in the heating mode as described the Heating Operation in section 4.

5.2 The defrost control in the heat pump unit checks to see if a defrost is needed every 30, 60 or 90 minutes of heat pump operation depending on the selectable setting by monitoring the state of the defrost thermostat attached to the outdoor coil.

5.3 If the temperature of the outdoor coil is low enough to cause the defrost thermostat to be closed when the defrost board checks it, the board will initiate a defrost cycle.

5.4 When a defrost cycle is initiated, the contacts of the HVDR relay on the defrost board open and turns off the outdoor fan. The contacts of the LVDR relay on the defrost board closes and supplies 24Vac to “O” and “W2”. The reversing valve is energized and the contacts on HR1 close and turns on the electric heater(s). The unit will continue to run in this mode until the defrost cycle is completed.

- a. For models with defrost control PCBDM133 or PCBDM160, a 30 second compressor delay at defrost initiation/termination is optional. As shipped from the factory, the control is set for the delay (“DLY”), which will turn the compressor off for 30 seconds while the reversing valve shifts to/from the cooling mode position. To bypass the delay, which typically reduces sound levels during defrost mode, change the pin settings from “DLY” to “NORM”.

5.5 When the temperature of the outdoor coil rises high enough to causes the defrost thermostat to open, the defrost cycle will be terminated. If at the end of the programmed 10 minute override time the defrost thermostat is still closed, the defrost board will automatically terminate the defrost cycle.

5.6 When the defrost cycle is terminated, the contacts of the HVDR relay on the defrost board will close to start the

outdoor fan and the contacts of the LVDR relay will open and turn off the reversing valve and electric heater(s). The unit will now be back in a normal heating mode with a heat pump demand for heating as described in the Heating Operation in section 4. See section 5.4a.

## **SEQUENCE OF OPERATION**

This document covers the basic sequence of operation for a typical application with a mercury bulb thermostat. When a digital/electronic thermostat is used, the on/off staging of the outdoor unit and auxiliary heat will vary. Refer to the installation instructions and wiring diagrams provided with the MBE for specific wiring connections, dip switch settings and system configuration.

## **MBE/AEPF WITH TWO STAGE ASX & DSX CONDENSERS**

### 1.0 COOLING OPERATION

**When used with the ASX & DSX two stage condensers, dip switch #4 must be set to the OFF position on the VSTB inside the MBE/AEPF. The “Y1” output from the indoor thermostat must be connected to the purple wire labeled “Ylow/Y1” inside the wire bundle marked “Thermostat” and the purple wire labeled “Ylow/Y1” inside the wire bundle marked “Outdoor Unit” must be connected to “Ylow/Y1” at the condenser. The “Y2” output from the indoor thermostat must be connected to the yellow wire labeled “Y/Y2” inside the wire bundle marked “Thermostat” and the yellow wire labeled “Y/Y2” inside the wire bundle marked “Outdoor Unit” must be connected to “Y/Y2” at the condenser. **The orange jumper wire from terminal “Y1” to terminal “O” on the VSTB inside the MBE/AEPF must remain connected.****

**1.1** On a demand for cooling, the room thermostat energizes “G” and “Y1” and 24Vac is supplied to “G” and “Ylow/Y1” of the MBE/AEPF unit. The VSTB inside the MBE/AEPF will turn on the blower motor and the motor will ramp up to 60% of the speed programmed in the motor based on the settings for dip switch 5 and 6. The VSTB will supply 24Vac to “Ylow/Y1” at the condenser and the compressor and condenser fan starts in low speed operation.

**1.2** If first stage cooling cannot satisfy the demand, the room thermostat will energize “Y2” and supply 24Vac to the MBE/AEPF unit. The blower motor will change to the cfm for high speed operation and the VSTB will supply 24Vac to “Y/Y2” at the condenser and the compressor and condenser fan will change to high speed operation. When the “Y2” demand is satisfied, the thermostat will remove the “Y2” demand and the VSTB will remove the 24Vac from “Y/Y2” at the condenser. The blower will drop to 60% of the programmed cfm and the compressor and condenser fan will change to low speed. **On most digital/electronic thermostats, “Y2” will remain energized until the first stage cooling demand “Y1” is satisfied and then the “G”, “Y1” and “Y2” demands will be removed.**

**1.3** When the first stage cooling demand, “Y1”, is satisfied, the room thermostat removes the 24Vac from “G” and

# SERVICING

“Y1”. The MBE/AEPF removes the 24Vac from “Ylow/Y1” at the condenser and the compressor and condenser fan are turned off. The blower motor will ramp down to a complete stop based on the time and rate programmed in the motor.

## 2.0 Heating Operation

**2.1** On a demand for heat, the room thermostat energizes “W1” and 24Vac is supplied to terminal “E/W1” of the VSTB inside the MBE/AEPF unit. The VSTB will turn on the blower motor and the motor will ramp up to the speed programmed in the motor based on the settings for dip switch 1 and 2. The VSTB will supply 24Vac to heat sequencer HR1 on the electric heater assembly.

**2.2** HR1 contacts M1 and M2 will close within 10 to 20 seconds and turn on heater element #1. At the same time, if the heater assembly contains a second heater element, HR1 will contain a second set of contacts, M3 and M4, which will close and turn on heater element #2.

**Note:** If more than two heater elements are on the heater assembly, it will contain a second heat sequencer, HR2, which will control the 3<sup>rd</sup> and 4<sup>th</sup> heater elements if available.

**For the 3<sup>rd</sup> and 4<sup>th</sup> heater elements to operate on a second stage heat demand, the PJ4 jumper on the VSTB inside the MBE/AEPF must be cut.** With the PJ4 jumper cut, the VSTB will run the blower motor on low speed on a “W1” only demand. If the first stage heat demand, “W1” cannot be satisfied by the heat pump, the temperature indoors will continue to drop. The room thermostat will then energize “W2” and 24Vac will be supplied to HR2 on the heater assembly and the blower motor will change to high speed. When the “W2” demand is satisfied, the room thermostat will remove the 24Vac from “W2” and the VSTB will remove the 24Vac from HR2. The contacts on HR2 will open between 30 to 70 seconds and heater elements #3 and #4 will be turned off and the blower motor will change to low speed. **On most digital/electronic thermostats, “W2” will remain energized until the first stage demand “W1” is satisfied and then the “W1” and “W2” demands will be removed.**

**2.3** When the “W1” heat demand is satisfied, the room thermostat will remove the 24Vac from “E/W1” and the VSTB removes the 24Vac from HR1. The contacts on HR1 will open between 30 to 70 seconds and turn off the heater element(s) and the blower motor ramps down to a complete stop.

## MBE/AEPF WITH TWO STAGE ASZ & DSZ HEAT PUMP UNITS

### 3.0 Cooling Operation

**When used with the ASZ & DSZ two stage heat pumps, dip switch #4 must be set to the OFF position on the VSTB inside the MBE/AEPF.** The “Y1” output from the indoor thermostat must be connected to the purple wire labeled “Ylow/Y1” inside the wire bundle marked “Thermostat” and the purple wire labeled “Ylow/Y1” inside the wire bundle marked “Outdoor Unit” must be connected to “Y” at the heat pump. The “Y2” output

from the indoor thermostat must be connected to the yellow wire labeled “Y/Y2” inside the wire bundle marked “Thermostat” and the yellow wire labeled “Y/Y2” inside the wire bundle marked “Outdoor Unit” must be connected to “Y/Y2” at the heat pump. **The orange jumper wire from terminal “Y1” to terminal “O” on the VSTB inside the MBE/AEPF must be removed.**

On heat pump units, when the room thermostat is set to the cooling mode, 24Vac is supplied to terminal “O” of the VSTB inside the MBE unit. The VSTB will supply 24Vac to “O” at the heat pump to energize the reversing valve. As long as the thermostat is set for cooling, the reversing valve will be in the energized position for cooling.

**3.1** On a demand for cooling, the room thermostat energizes “G” and “Y1” and 24Vac is supplied to “G” and “Ylow/Y1” of the MBE unit. The VSTB inside the MBE will turn on the blower motor and the motor will ramp up to 60% of the speed programmed in the motor based on the settings for dip switch 5 and 6. The VSTB will supply 24Vac to “Y” at the heat pump and the compressor and outdoor fan starts in low speed operation.

**3.2** If first stage cooling cannot satisfy the demand, the room thermostat will energize “Y2” and supply 24Vac to “Y/Y2” of the MBE unit. The blower motor will change to the cfm for high speed operation and the VSTB will supply 24Vac to “Y2” at the heat pump. The compressor and outdoor fan will change to high speed operation. When the “Y2” demand is satisfied, the thermostat will remove the “Y2” demand and the VSTB will remove the 24Vac from “Y2” at the heat pump. The blower will drop to 60% of the programmed cfm and the compressor and outdoor fan will change to low speed operation. **On most digital/electronic thermostats, “Y2” will remain energized until the first stage cooling demand “Y1” is satisfied and then the “G”, “Y1” and “Y2” demands will be removed.**

**3.3** When the first stage cooling demand, “Y1”, is satisfied, the room thermostat removes the 24Vac from “G” and “Y1”. The VSTB removes the 24Vac from “Y” at the heat pump and the compressor and outdoor fan are turned off. The blower motor will ramp down to a complete stop based on the time and rate programmed in the motor.

### 4.0 Heating Operation

On heat pump units, when the room thermostat is set to the heating mode, the reversing valve is not energized. As long as the thermostat is set for heating, the reversing valve will be in the de-energized position for heating except during a defrost cycle. Some installations may use one or more outdoor thermostats to restrict the amount of electric heat that is available above a preset ambient temperature. Use of optional controls such as these can change the operation of the electric heaters during the heating mode. This sequence of operation does not cover those applications.

**4.1** On a demand for first stage heat with heat pump units, the room thermostat energizes “G” and “Y1” and 24Vac is supplied to “G” and “Ylow/Y1” of the MBE/AEPF. The

# SERVICING

VSTB will turn on the blower motor and the motor will ramp up to 60% of the speed programmed in the motor based on the settings of dip switch 1 and 2. The VSTB will supply 24Vac to “Y” at the heat pump. **The compressor will start on low stage and outdoor fan will start on low speed on a “Y1” heating demand but the blower motor will deliver only 60% of the programmed cfm for high speed heating operation.**

**4.2** If a thermostat that provides a “Y2” demand in heating is used and first stage heating cannot satisfy the demand, the room thermostat will energize “Y2” and supply 24Vac to “Y/Y2” of the MBE unit. The blower motor will change to the cfm for high speed heating operation and the VSTB will supply 24Vac to “Y/Y2” at the heat pump. The outdoor fan will change to high speed operation and compressor will shift to high stage. If the “Y2” demand is present and becomes satisfied, the thermostat will remove the “Y2” demand and the VSTB will remove the 24Vac from “Y/Y2” at the heat pump. The blower will drop to 60% of the programmed cfm and the outdoor fan will change to low speed. On most digital/electronic thermostats, “Y2” will remain energized until the first stage heating demand “Y1” is satisfied and then the “G”, “Y1” and “Y2” demands will be removed.

**4.3** If the heat pump operation cannot satisfy the demand, the room thermostat energizes “W2/W3” and 24Vac is supplied to terminal “E/W1” of the VSTB inside the MBE/AEPF unit. The VSTB will supply 24Vac to heat sequencer HR1 on the electric heater assembly.

**4.4** HR1 contacts M1 and M2 will close within 10 to 20 seconds and turn on heater element #1. At the same time, if the heater assembly contains a second heater element, HR1 will contain a second set of contacts, M3 and M4, which will close and turn on heater element #2.

**Note:** If more than two heater elements are on the heater assembly, it will contain a second heat sequencer, HR2, which will control the 3<sup>rd</sup> and 4<sup>th</sup> heater elements if available.

**For the 3<sup>rd</sup> and 4<sup>th</sup> heater elements to operate on a second stage auxiliary heat demand, the PJ4 jumper on the VSTB inside the MBE/AEPF must be cut.** If the “W2/W3” demand cannot be satisfied by the heat pump, the temperature indoors will continue to drop. The room thermostat will then energize “W3/W4” and 24Vac will be supplied to “W/W2” of the MBE. The VSTB will supply 24Vac to HR2 on the electric heater assembly. When the “W3/W4” demand is satisfied, the room thermostat will remove the 24Vac from “W/W2” of the MBE/AEPF. The contacts on HR2 will open between 30 to 70 seconds and heater elements #3 and #4 will be turned off. **On most digital/electronic thermostats, “W3/W4” will remain energized until the first stage demand “Y1” is satisfied and then the “G”, “Y1”, “Y2” “W2/W3” and “W3/W4” demands will be removed.**

**4.5** As the temperature indoors increase, it will reach a point where the “W2/W3” demand is satisfied. When this happens, the room thermostat will remove the 24Vac from “E/W1” of the MBE/AEPF. The contacts on HR1 will open

between 30 to 70 seconds and turn off the 1<sup>st</sup> and 2<sup>nd</sup> heater elements. If the “Y2” demand is present and becomes satisfied the room thermostat will remove the 24Vac from “Y/Y2” of the MBE and the blower motor will change to 60% of the programmed cfm. The VSTB will remove the 24Vac from “Y/Y2” at the heat pump and the outdoor fan will change to low speed operation. The heat pump remains on along with the blower motor because the “Y1” demand for first stage heat will still be present.

**4.6** When the first stage heat demand “Y1” is satisfied, the room thermostat will remove the 24Vac from “G” and “Ylo/Y1” of the MBE/AEPF. The VSTB removes the 24Vac from “Ylo/Y1” at the heat pump and the compressor and outdoor fan are turned off. The blower motor will ramp down to a complete stop based on the time and rate programmed in the motor control.

## 5.0 Defrost Operation

On heat pump units, when the room thermostat is set to the heating mode, the reversing valve is not energized. As long as the thermostat is set for heating, the reversing valve will be in the de-energized position for heating except during a defrost cycle.

**5.1** The heat pump will be on and operating in the heating mode as described the Heating Operation in section 4.

**5.2** The defrost control in the heat pump unit checks to see if a defrost is needed every 30, 60 or 90 minutes of heat pump operation depending on the selectable setting by monitoring the state of the defrost thermostat attached to the outdoor coil.

**5.3** If the temperature of the outdoor coil is low enough to cause the defrost thermostat to be closed when the defrost board checks it, the board will initiate a defrost cycle.

**5.4** When a defrost cycle is initiated, the contacts of the HVDR relay on the defrost board open and turns off the outdoor fan. The contacts of the LVDR relay on the defrost board closes and supplies 24Vac to “O” and “W2”. The reversing valve is energized and the contacts on HR1 close and turns on the electric heater(s). The unit will continue to run in this mode until the defrost cycle is completed.

a. For models with defrost control PCBDM133 or PCBDM160, a 30 second compressor delay at defrost initiation/termination is optional. As shipped from the factory, the control is set for the delay (“DLY”), which will turn the compressor off for 30 seconds while the reversing valve shifts to/from the cooling mode position. To bypass the delay, which typically reduces sound levels during defrost mode, change the pin settings from “DLY” to “NORM”.

**5.5** When the temperature of the outdoor coil rises high enough to causes the defrost thermostat to open, the defrost cycle will be terminated. If at the end of the programmed 10 minute override time the defrost thermostat is still closed, the defrost board will automatically terminate the defrost cycle.

# SERVICING

DELETED 5.6 - 12/16/14

## SEQUENCE OF OPERATION

### *AVPTC/MBVC with Single Stage Condensers (24VAC Legacy Wired Systems)*

#### 1.0 Cooling Operation

- 1.1 On a demand for single stage cooling operation, the thermostat closes the "G" and "Y" contacts providing 24VAC to the "G", "Y1", and "Y2" terminals at the integrated air handler control. The integrated AH control initiates the selected cooling ramping profile after any blower ON delays have expired. After completing any blower ON delays and ramping profile, the control operates the variable speed ECM motor at the demanded airflow.
- 1.2 The compressor and condenser fan motor is energized by the closing of the thermostat "Y" contacts.
- 1.3 The system operates at single stage cooling.
- 1.4 Upon satisfying the thermostat, the "G" and "Y" thermostat contacts open, removing 24VAC from the both the outdoor condenser and integrated air handler control. The compressor and condenser fan motor are both de-energized immediately. The integrated AH control continues to operate the ECM blower motor for an OFF delay period, then applies the off portion of the selected ramping profile. The ECM blower motor is then de-energized.

#### 2.0 Heating Operation

- 2.1 On a demand for auxiliary heat operation, the thermostat closes the "W1" contacts providing 24VAC to the "W1" terminal at the integrated air handler control. The integrated AH control initiates the heating ramping profile after any blower ON delays have expired. After completing any blower ON delays and ramping profile, the control operates the variable speed ECM motor at the demanded airflow.
- 2.2 The system operates at low stage auxiliary heat.
- 2.3 If the thermostat demand cannot be met on low stage auxiliary heat, the thermostat will close the "W2" contacts, providing 24VAC to the "W2" terminal at the integrated AH control. Thermostat "W1" contacts remain closed.
- 2.4 Upon receiving the high stage auxiliary heat demand, the control operates the ECM blower motor at the demanded airflow.
- 2.5 The system operates at high stage auxiliary heat as demanded by the thermostat.
- 2.6 Upon satisfying the thermostat, the "W1" thermostat contacts (or "W1" and "W2" contacts) open, removing 24VAC from the integrated air handler control. The integrated AH control continues to operate the ECM blower motor for an OFF delay period, then applies the off portion of the heating ramping profile. The ECM blower motor is then de-energized.

#### 3.0 Continuous Fan Operation

- 3.1 On a demand for continuous fan operation, the thermostat closes the "G" contacts providing 24VAC to the "G" terminal at the integrated air handler control. The control energizes the variable speed ECM motor at 30% of the air handler's maximum airflow capability.
- 3.2 Removing the thermostat demand for continuous fan opens the "G" contacts, removing 24VAC from the integrated air handler control. The integrated AH control immediately de-energizes the ECM blower motor.

### *AVPTC/MBVC with Single Stage Heat Pumps (24VAC Legacy Wired Systems)*

#### 1.0 Cooling Operation

- 1.1 On a demand for single stage cooling operation, the thermostat closes the "G", "O", and "Y" contacts providing 24VAC to the "G", "O", "Y1", and "Y2" terminals at the integrated air handler control. The integrated AH control initiates the selected cooling ramping profile after any blower ON delays have expired. After completing any blower ON delays and ramping profile, the control operates the variable speed ECM motor at the demanded airflow.
- 1.2 The compressor and condenser fan motor is energized by the closing of the thermostat "Y" contacts. The reversing valve is energized by the closing of the thermostat "O" contacts.
- 1.3 The system operates at single stage cooling.
- 1.4 Upon satisfying the thermostat, the "G", "O", and "Y" thermostat contacts open, removing 24VAC from the both the outdoor condenser and integrated air handler control. The compressor, condenser fan motor, and reversing valve are de-energized immediately. The integrated AH control continues to operate the ECM blower motor for an OFF delay period, then applies the off portion of the selected ramping profile. The ECM blower motor is then de-energized.

#### 2.0 Heating Operation

- 2.1 On a demand for heat pump heating, the room thermostat closes the "G" and "Y" contacts, providing 24VAC to the "G" and "Y" terminals at the integrated air handler control. The integrated AH control initiates the heat pump heating ramping profile after any blower ON delays have expired. After completing any blower ON delays and ramping profile, the control operates the variable speed ECM motor at the demanded airflow.
- 2.2 The compressor and condenser fan motor are energized by the closing of the thermostat "Y" contacts.
- 2.3 The system operates at single stage heat pump heat.
- 2.4 If the thermostat demand cannot be met with heat pump heating, the thermostat will close the "W1/W2" contacts, providing 24VAC to the "W1" or "W1" and "W2" terminals at the integrated AH control. Thermostat "G" and "Y" contacts remain closed.

# SERVICING

2.5 Upon receiving a demand for auxiliary heat, the control determines the appropriate airflow demand for heat pump + auxiliary heat operation and operates the ECM blower motor at that airflow demand. The control determines which airflow demand is greatest and applies that demand when operating the ECM blower motor.

2.6 The system operates at single stage heat pump heating plus auxiliary heat.

2.5 Upon satisfying the thermostat, the "G" and "Y" thermostat contacts (or "G", "Y" and "W1/W2" contacts) open, removing 24VAC from the integrated air handler control. The integrated AH control continues to operate the ECM blower motor for an OFF delay period, then applies the off portion of the heat pump heating ramping profile. The ECM blower motor is then de-energized.

## **3.0 Continuous Fan Operation**

3.1 On a demand for continuous fan operation, the thermostat closes the "G" contacts providing 24VAC to the "G" terminal at the integrated air handler control. The control energizes the variable speed ECM motor at 30% of the air handler's maximum airflow capability.

3.2 Removing the thermostat demand for continuous fan opens the "G" contacts, removing 24VAC from the integrated air handler control. The integrated AH control immediately de-energizes the ECM blower motor.

## **4.0 Defrost Operation**

4.1 The control in the outdoor unit determines when a defrost cycle is needed. Upon determining that a defrost cycle is needed, the outdoor control de-energizes the condenser fan motor and energizes the reversing valve. A "W1" signal is sent from the outdoor unit control to the integrated air handler control.

4.2 The air handler control energizes the electric heat sequencer output to turn on the electric heaters. The appropriate airflow demand is provided to the motor (greater of heat pump or auxiliary heat).

4.3 At the conclusion of the defrost cycle, the outdoor unit control removes the "W1" output to the integrated air handler control, de-energizes the reversing valve and re-energizes the condenser fan motor.

## **5.0 Emergency Heat Operation**

5.1 On a demand for emergency heat operation, the thermostat closes the "W1/W2" contacts providing 24VAC to the "W1" terminal at the integrated air handler control. The integrated AH control initiates the heating ramping profile after any blower ON delays have expired. After completing any blower ON delays and ramping profile, the control operates the variable speed ECM motor at the demanded airflow.

5.2 The system operates at emergency heat.

5.3 Upon satisfying the thermostat emergency heat demand, the "W1" thermostat contacts open, removing 24VAC from the integrated air handler control. The integrated AH control continues to operate the ECM

blower motor for an OFF delay period, then applies the off portion of the heating ramping profile. The ECM blower motor is then de-energized.

## ***AVPTC/MBVC with 2-Stage Condensers (24VAC Legacy Wired Systems)***

### **1.0 Cooling Operation**

1.1 On a demand for low stage cooling operation, the thermostat closes the "G" and "Y1" contacts providing 24VAC to the "G" and "Y1" terminals at the integrated air handler control. The integrated AH control initiates the selected cooling ramping profile after any blower ON delays have expired. After completing any blower ON delays and ramping profile, the control operates the variable speed ECM motor at the demanded airflow.

1.2 The compressor and condenser fan motor are energized by the closing of the thermostat "Y1" contacts.

1.3 The system operates at low stage cooling.

1.4 If the thermostat demand cannot be met with low stage cooling, the thermostat closes the "Y2" contacts, providing 24VAC to the "Y2" terminal at the AH control. The integrated AH control operates the ECM blower motor at the high stage cooling airflow demand. Thermostat "G" and "Y1" contacts remain closed.

1.5 The compressor and condenser fan motor high stage speeds are energized by the closing of the thermostat "Y2" contacts.

1.6 The system operates at high stage cooling.

1.7 Upon satisfying the thermostat, the "G", "Y1" and "Y2" thermostat contacts open, removing 24VAC from the both the outdoor condenser and integrated air handler control. The compressor and condenser fan motor are both de-energized immediately. The integrated AH control continues to operate the ECM blower motor for an OFF delay period, then applies the off portion of the selected ramping profile. The ECM blower motor is then de-energized.

### **2.0 Heating Operation**

2.1 On a demand for auxiliary heat operation, the thermostat closes the "W1" contacts providing 24VAC to the "W1" terminal at the integrated air handler control. The integrated AH control initiates the heating ramping profile after any blower ON delays have expired. After completing any blower ON delays and ramping profile, the control operates the variable speed ECM motor at the demanded airflow.

2.2 The system operates at low stage auxiliary heat.

2.3 If the thermostat demand cannot be met on low stage auxiliary heat, the thermostat will close the "W2" contacts, providing 24VAC to the "W2" terminal at the integrated AH control. Thermostat "W1" contacts remain closed.

2.4 The system operates on high stage auxiliary heat.

# SERVICING

2.5 Upon receiving the high stage auxiliary heat demand, the control operates the ECM blower motor at the high stage auxiliary heat airflow.

2.6 Upon satisfying the thermostat, the "W1" thermostat contacts (or "W1" and "W2" contacts) open, removing 24VAC from the integrated air handler control and outdoor unit. The compressor and condensor fan motor are immediately de-energized. The integrated AH control continues to operate the ECM blower motor for an OFF delay period, then applies the off portion of the heating ramping profile. The ECM blower motor is then de-energized.

## **3.0 Continuous Fan Operation**

3.1 On a demand for continuous fan operation, the thermostat closes the "G" contacts providing 24VAC to the "G" terminal at the integrated air handler control. The control energizes the variable speed ECM motor at 30% of the air handler's maximum airflow capability.

3.2 Removing the thermostat demand for continuous fan opens the "G" contacts, removing 24VAC from the integrated air handler control. The integrated AH control immediately de-energizes the ECM blower motor.

## **AVPTC/MBVC with 2-Stage Heat Pumps (24VAC Legacy Wired Systems)**

### **1.0 Cooling Operation**

1.1 On a demand for low stage cooling operation, the thermostat closes the "G", "O", and "Y1" contacts providing 24VAC to the "G", "O", and "Y1" terminals at the integrated air handler control. The integrated AH control initiates the selected cooling ramping profile after any blower ON delays have expired. After completing any blower ON delays and ramping profile, the control operates the variable speed ECM motor at the low stage cooling airflow.

1.2 The low stage compressor and condensor fan motor speeds are energized by the closing of the thermostat "Y1" contacts. The reversing valve is energized with the closing of the thermostat "O" contacts.

1.3 The system operates at low stage cooling.

1.4 If the thermostat demand cannot be met with low stage cooling, the thermostat closes the "Y2" contacts, providing 24VAC to the "Y2" terminal at the AH control. The integrated AH control operates the ECM blower motor at the high stage cooling airflow demand. Thermostat "G", "O", and "Y1" contacts remain closed.

1.5 The compressor and condensor fan motor high stage speeds are energized by the closing of the thermostat "Y2" contacts.

1.6 The system operates at high stage cooling.

1.7 Upon satisfying the thermostat, the "G", "O", and "Y1" (or "Y1" and "Y2") thermostat contacts open, removing 24VAC from the both the outdoor condensor and integrated air handler control. The compressor, condensor fan motor, and reversing valve are all de-energized immediately. The integrated AH control

continues to operate the ECM blower motor for an OFF delay period, then applies the off portion of the selected ramping profile. The ECM blower motor is then de-energized.

### **2.0 Heating Operation**

2.1 On a demand for low stage heat pump heating, the room thermostat closes the "G" and "Y1" contacts, providing 24VAC to the "G" and "Y1" terminals at the integrated air handler control. The integrated AH control initiates the heat pump heating profile after any blower ON delays have expired. After completing any blower ON delays and ramping profile, the control operates the variable speed ECM motor at the low stage heat pump airflow.

2.2 The low stage compressor and condensor fan motor speeds are energized by the closing of the thermostat "Y1" contacts.

2.3 The system operates at low stage heat pump heating.

2.4 If the thermostat demand cannot be met with low stage heat pump heating, the thermostat will close the "Y2" contacts, providing 24VAC to the "Y2" terminals at the integrated AH control and heat pump. Thermostat "G" and "Y1" contacts remain closed. The air handler control operates the ECM blower motor at the high stage heat pump heating airflow.

2.5 The system operates at high stage heat pump heating.

2.6 If the thermostat demand cannot be met with high stage heat pump heating, the thermostat will close the "W1/W2" contacts, providing 24VAC to the "W1" or "W1" and "W2" terminals at the integrated AH control. Thermostat "G", "Y1", and "Y2" contacts remain closed.

2.7 Upon receiving a demand for auxiliary heat, the control determines the appropriate airflow demand for high stage heat pump + auxiliary heat operation and operates the ECM blower motor at that airflow demand. The control determines which airflow demand is greatest and applies that demand when operating the ECM blower motor.

2.8 The system operates at high stage heat pump heating plus auxiliary heat.

2.9 Upon satisfying the thermostat, the "G" and "Y1" thermostat contacts (or "G", "Y1", "Y2" and "W1/W2" contacts) open, removing 24VAC from the integrated air handler control. The compressor and condensor fan motor are de-energized immediately. The integrated AH control continues to operate the ECM blower motor for an OFF delay period, then applies the off portion of the heat pump heating ramping profile. The ECM blower motor is then de-energized.

### **3.0 Continuous Fan Operation**

3.1 On a demand for continuous fan operation, the thermostat closes the "G" contacts providing 24VAC to the "G" terminal at the integrated air handler control. The control energizes the variable speed ECM motor at 30% of the air handler's maximum airflow capability.

# SERVICING

3.2 Removing the thermostat demand for continuous fan opens the "G" contacts, removing 24VAC from the integrated air handler control. The integrated AH control immediately de-energizes the ECM blower motor.

## **4.0 Defrost Operation**

4.1 The control in the outdoor unit determines when a defrost cycle is needed. Upon determining that a defrost cycle is needed, the outdoor control de-energizes the condenser fan motor and energizes the reversing valve. A "W1" signal is sent from the outdoor unit control to the integrated air handler control.

4.2 The air handler control energizes the electric heat sequencer output to turn on the electric heaters. The appropriate airflow demand is provided to the motor (greater of heat pump or auxiliary heat).

4.3 At the conclusion of the defrost cycle, the outdoor unit control removes the "W1" output to the integrated air handler control, de-energizes the reversing valve and re-energizes the condenser fan motor.

## **5.0 Emergency Heat Operation**

5.1 On a demand for emergency heat operation, the thermostat closes the "W1/W2" contacts providing 24VAC to the "W1" terminal at the integrated air handler control. The integrated AH control initiates the heating ramping profile after any blower ON delays have expired. After completing any blower ON delays and ramping profile, the control operates the variable speed ECM motor at the emergency heat airflow.

5.2 The system operates at emergency heat.

5.3 Upon satisfying the thermostat emergency heat demand, the "W1" thermostat contacts open, removing 24VAC from the integrated air handler control. The integrated AH control continues to operate the ECM blower motor for an OFF delay period, then applies the off portion of the heating ramping profile. The ECM blower motor is then de-energized.

## **AVPTC/MBVC with ASXC/DSXC Condenser and CTK0\* Communicating Thermostat**

The AVPTC or MBVC air handle/modular blower matched with an ASXC or DSXC condensing unit and CTK0\* communicating thermostat constitute a network. The three components, or subsystems, making up the system communicate with one another with information passed between all three components. This leads to a somewhat non-traditional manner in which the system components receive commands for system operation. All system commands are routed from the component through the network to the appropriate destination component.

**NOTE:** The individual subsystems will cease operation if the request for operation is NOT refreshed after 5 minutes. This is a built-in safe guard to prevent the possibility of runaway operation.

## **1.0 Cooling Operation - Low and High Stage Cool**

1.1 The CTK0\* thermostat sends a request for low stage cooling through the network to the unitary (UC) control

in the condenser. The UC control receives the command and processes any compressor and fan delays.

1.2 The UC control sends a request for low stage fan speed to the air handler/modular blower. The blower energizes the ECM blower motor at the appropriate speed.

1.3 The condenser energizes the compressor and condenser fan motor at the appropriate low stage speeds.

1.4 The system operates at low stage cooling.

1.5 If the thermostat demand cannot be met on low stage cooling, the CTK0\* thermostat sends a request for high stage cooling to the condenser. The condenser in turn sends a request for high stage fan speed to the air handler/modular blower. The blower increases the blower speed to the high stage cooling speed.

1.6 The condenser's unitary control energizes the high stage compressor solenoid and switches the condenser fan motor to high speed.

1.7 The system operates at high stage cooling.

1.8 Once the thermostat demand is satisfied, the CTK0\* thermostat commands the UC control to end cooling operation. The condenser de-energizes the compressor and condenser fan motor. The UC control continues providing a fan request until any cooling blower OFF delays have expired.

## **2.0 Heating Operation - Auxiliary/Emergency Heat**

2.1 The CTK0\* thermostat sends a request for emergency heat to the air handler/modular blower.

2.2 The air handler control energizes the ECM blower motor at the emergency heat speed. The electric heat sequencer outputs are also energized, thus energizing the electric heaters.

2.3 The system operates at emergency heat.

2.4 Once the thermostat demand is satisfied, the CTK0\* thermostat commands the air handler/modular blower to end emergency heat operation. The air handler control de-energizes the electric heat sequencer outputs. The ECM blower motor remains energized until any blower OFF delay timing has expired.

## **3.0 Continuous Fan Operation**

3.1 With a demand for continuous fan operation, the CTK0\* thermostat sends a fan request to the integrated air handler control along with a fan demand. The control energizes the variable speed ECM motor at fan demand provided by the thermostat. The fan demand provided by the thermostat will be 30%, 50%, or 70% of the air handler's maximum airflow capability. The continuous fan demand is set from the thermostat as low, medium, or high.

3.2 If the thermostat demand for continuous fan is removed, the CTK0\* thermostat commands the integrated air handler control to end continuous fan operation. The integrated AH control immediately de-energizes the ECM blower motor.

# SERVICING

## **AVPTC/MBVC with ASZC/DSZC Heat Pump and CTK0\* Communicating Thermostat**

The AVPTC or MBVC air handle/modular blower matched with an ASZC or DSZC condensing unit and CTK0\* communicating thermostat constitute a network. The three components, or subsystems, making up the system communicate with one another with information passed between all three components. This leads to a somewhat non-traditional manner in which the system components receive commands for system operation. All system commands are routed from the component through the network to the appropriate destination component.

**NOTE:** Communicating heat pump systems are designed to utilize a balance point temperature. The balance point temperature in part controls heat pump operation. If the outdoor temperature is below the balance point, the heat pump is disabled and only electric heat is available for heating. The balance point temperature is set via the CTK0\* thermostat in the advanced installer's configuration menu.

The CTK0\* thermostat also allows the user to disable the electric heaters in the air handler/modular blower depending on the outdoor temperature. The electric heaters are disabled if the outdoor temperature is above the set point. All heating is supplied by the heat pump.

The outdoor air temperature is acquired from the outdoor air temperature (OAT) sensor included with the ASZC/DSZC heat pump models. Faults with the sensor will affect heating operation.

**NOTE:** The individual subsystems will cease operation if the request for operation is NOT refreshed after 5 minutes. This is a built-in safe guard to prevent the possibility of runaway operation.

### **1.0 Cooling Operation - Low and High Stage Cool**

- 1.1 The CTK0\* thermostat sends a request for low stage cooling through the network to the unitary (UC) control in the heat pump. The UC control receives the command and processes any compressor and fan delays.
- 1.2 The UC control sends a request for low stage fan speed to the air handler/modular blower. The blower energizes the ECM blower motor at the appropriate speed.
- 1.3 The heat pump energizes the compressor and condenser fan motor at the appropriate low stage speeds. The reversing valve is also energized.
- 1.4 The system operates at low stage cooling.
- 1.5 If the thermostat demand cannot be met on low stage cooling, the CTK0\* thermostat sends a request for high stage cooling to the heat pump. The heat pump in turn sends a request for high stage fan speed to the air handler/modular blower. The AH control increases the blower speed to the high stage cooling speed.
- 1.6 The heat pump's unitary control energizes the high stage compressor solenoid and switches the condenser fan motor to high speed. The reversing valve remains energized.

- 1.7 The system operates at high stage cooling.
- 1.8 Once the thermostat demand is satisfied, the CTK0\* thermostat commands the UC control to end cooling operation. The heat pump de-energizes the compressor, condenser fan motor, and reversing valve. The UC control continues providing a fan request until any cooling blower OFF delays have expired.

### **2.0 Heating Operation**

#### ***Outdoor Temperature Above the Heat Pump Balance Point***

- 2.1 The CTK0\* thermostat sends a request for the outdoor air temperature to the heat pump. The heat pump returns an outdoor air temperature that is above the balance point temperature. Heat pump heating is enabled.
- 2.2 The CTK0\* thermostat sends a request for low stage heat pump heating to the unitary (UC) control in the heat pump. The UC control receives the command and processes any compressor and fan delays.
- 2.3 The UC control sends a request for low stage fan speed to the air handler/modular blower. The blower energizes the ECM blower motor at the appropriate speed.
- 2.4 The condenser energizes the compressor and condenser fan motor at the appropriate low stage speeds.
- 2.5 The system operates at low stage heat pump heating.
- 2.6 If the thermostat demand cannot be met on low stage heat pump heating, the CTK0\* thermostat sends a request for high stage heat pump heating to the heat pump. The heat pump in turn sends a request for high stage fan speed to the air handler/modular blower. The AH control increases the blower speed to the high stage heat pump heating speed.
- 2.7 The heat pump's unitary control energizes the high stage compressor solenoid and switches the condenser fan motor to high speed.
- 2.8 The system operates at high stage heat pump heating.
- 2.9 If the thermostat demand cannot be met on high stage heat pump heating, the CTK0\* thermostat sends a request for auxiliary heat to the air handler/modular blower.
- 2.10 Upon receiving a demand for auxiliary heat, the air handler control determines the appropriate airflow for high stage heat pump + auxiliary heat operation and operates the ECM blower motor at that airflow demand. The air handler control determines which airflow demand is greatest and applies that demand when operating the ECM blower motor.
- 2.11 The system operates at high stage heat pump heating plus auxiliary heat.
- 2.12 Once the thermostat demand is satisfied, the CTK0\* thermostat commands the heat pump to end heat pump heating operation. The compressor and outdoor fan motor are de-energized.



# SERVICING

The air handler/modular blower is commanded to end auxiliary heat operation. The air handler control de-energizes the electric heat sequencer outputs. The ECM blower motor remains energized until any blower OFF delay timing has expired.

## **Outdoor Temperature Below the Heat Pump Balance Point**

- 2.1 The CTK0\*\*\* thermostat sends a request for the outdoor air temperature to the heat pump. The heat pump returns an outdoor air temperature that is below the balance point temperature. Heat pump heating is disabled.
- 2.2 The CTK0\*\*\* thermostat sends a request for auxiliary heat to the air handler/modular blower.
- 2.2 The air handler control energizes the ECM blower motor at the auxiliary heat speed. The electric heat sequencer outputs are also energized, thus energizing the electric heaters.
- 2.3 The system operates at auxiliary heat.
- 2.4 Once the thermostat demand is satisfied, the CTK0\* thermostat commands the air handler/modular blower to end auxiliary heat operation. The air handler control de-energizes the electric heat sequencer outputs. The ECM blower motor remains energized until any blower OFF delay timing has expired.

## **3.0 Continuous Fan Operation**

- 3.1 With a demand for continuous fan operation, the CTK0\* thermostat sends a fan request to the integrated air handler control along with a fan demand. The control adjustable via the CTK0\* thermostat. The compressor delay is intended to eliminate compressor noise during the reversing valve shift.) The compressor will energized (or re-energized) at high stage.
- 3.2 If the thermostat demand for continuous fan is removed, the CTK0\* thermostat commands the integrated air handler control to end continuous fan operation. The integrated AH control immediately de-energizes the ECM blower motor.

## **4.0 Defrost Operation**

- 4.1 While the system is operating in heat pump heating (see **2.0 Heating Operation**), the control in the outdoor unit may determine that a defrost cycle is needed. Upon determining that a defrost cycle is needed, the UC control de-energizes the condenser fan motor and energizes the reversing valve.
- 4.2 The compressor may be de-energized for a short delay during the reversing valve shift. (The delay period is adjustable via the CTK0\* thermostat. The compressor delay is intended to eliminate compressor noise during the reversing valve shift.) The compressor will energize (or re-energize) at high stage.
- 4.3 The UC control sends a request for defrost operation to the integrated air handler control. The air handler control energizes the electric heat sequencer outputs and operates the ECM blower motor at the electric heat speed.

4.4 Once the defrost cycle is terminated, the heat pump commands the air handler/modular blower to end defrost operation.

4.5 The system returns to heat pump heating operation that was in effect prior to the defrost cycle.

## **5.0 Emergency Heat Operation**

- 5.1 The CTK0\* thermostat sends a request for emergency heat to the air handler/modular blower.
- 5.2 The air handler control energizes the ECM blower motor at the emergency heat speed. The electric heat sequencer outputs are also energized, thus energizing the electric heaters.
- 5.3 The system operates at emergency heat.
- 5.4 Once the thermostat demand is satisfied, the CTK0\* thermostat commands the air handler/modular blower to end emergency heat operation. The air handler control de-energizes the electric heat sequencer outputs. The ECM blower motor remains energized until any blower OFF delay timing has expired. energizes the variable speed ECM motor at fan demand provided by the thermostat. The fan demand provided by the thermostat will be 30%, 50%, or 70% of the air handler's maximum airflow capability. The continuous fan demand is set from the thermostat as low, medium, or high.

## **S-50 CHECKING HEATER LIMIT CONTROL(S) (OPTIONAL ELECTRIC HEATERS)**

Each individual heater element is protected with an automatic rest limit control connected in series with each element to prevent overheating of components in case of low airflow. This limit control will open its circuit at approximately 150°F. to 160°F and close at approximately 110°F.



### **WARNING**

**Disconnect ALL power before servicing.**

1. Remove the wiring from the control terminals.
2. Using an ohmmeter test for continuity across the normally closed contacts. No reading indicates the control is open - replace if necessary. Make sure the limits are cool before testing.

**IF FOUND OPEN - REPLACE - DO NOT WIRE AROUND.**

## **S-52 CHECKING HEATER ELEMENTS**

Optional electric heaters may be added, in the quantities shown in the spec sheet for each model unit, to provide electric resistance heating. Under no condition shall more heaters than the quantity shown be installed.

# SERVICING



**⚠ WARNING**  
**HIGH VOLTAGE!**  
 Disconnect ALL power before servicing or installing. Multiple power sources may be present. Failure to do so may cause property damage, personal injury or death.

**NOTE:** The temperature rise table is for sea level installations. The temperature rise at a particular KW and CFM will be greater at high altitudes, while the external static pressure at a particular CFM will be less.

1. Disassemble and remove the heating element(s).
2. Visually inspect the heater assembly for any breaks in the wire or broken insulators.
3. Using an ohmmeter, test the element for continuity - no reading indicates the element is open. Replace as necessary.

## S-60 ELECTRIC HEATER (OPTIONAL ITEM)

Optional electric heaters may be added, in the quantities shown in the specifications section, to provide electric resistance heating. Under no condition shall more heaters than the quantity shown be installed.

The low voltage circuit in the air handler is factory wired and terminates at the location provided for the electric heater(s). A minimum of field wiring is required to complete the installation.

Other components such as a Heating/Cooling Thermostat and Outdoor Thermostats are available to complete the installation.

The system CFM can be determined by measuring the static pressure external to the unit. The installation manual supplied with the blower coil, or the blower performance table in the service manual, shows the CFM for the static measured.

Alternately, the system CFM can be determined by operating the electric heaters and indoor blower WITHOUT having the compressor in operation. Measure the temperature rise as close to the blower inlet and outlet as possible.

If other than a 240V power supply is used, refer to the **BTUH CAPACITY CORRECTION FACTOR** chart below.

| TEMPERATURE RISE (°F) @ 240V |        |        |        |        |         |         |         |         |
|------------------------------|--------|--------|--------|--------|---------|---------|---------|---------|
| CFM                          | 3.0 kW | 4.8 kW | 7.2 kW | 9.6 kW | 14.4 kW | 19.2 kW | 24.0 kW | 28.8 kW |
| 600                          | 16     | 25     | 38     | 51     | -       | -       | -       | -       |
| 700                          | 14     | 22     | 33     | 43     | -       | -       | -       | -       |
| 800                          | 12     | 19     | 29     | 38     | 57      | -       | -       | -       |
| 900                          | 11     | 17     | 26     | 34     | 51      | -       | -       | -       |
| 1000                         | 10     | 15     | 23     | 30     | 46      | -       | -       | -       |
| 1100                         | 9      | 14     | 21     | 27     | 41      | 55      | -       | -       |
| 1200                         | 8      | 13     | 19     | 25     | 38      | 50      | -       | -       |
| 1300                         | 7      | 12     | 18     | 23     | 35      | 46      | -       | -       |
| 1400                         | 7      | 11     | 16     | 22     | 32      | 43      | 54      | 65      |
| 1500                         | 6      | 10     | 15     | 20     | 30      | 40      | 50      | 60      |
| 1600                         | 6      | 9      | 14     | 19     | 28      | 38      | 47      | 57      |
| 1700                         | 6      | 9      | 14     | 18     | 27      | 36      | 44      | 53      |
| 1800                         | 5      | 8      | 13     | 17     | 25      | 34      | 42      | 50      |
| 1900                         | 5      | 8      | 12     | 16     | 24      | 32      | 40      | 48      |
| 2000                         | 5      | 8      | 12     | 15     | 23      | 30      | 38      | 45      |
| 2100                         | 5      | 7      | 11     | 14     | 22      | 29      | 36      | 43      |
| 2200                         | 4      | 7      | 11     | 14     | 21      | 27      | 34      | 41      |
| 2300                         | 4      | 7      | 10     | 13     | 20      | 26      | 33      | 39      |

| ELECTRIC HEATER CAPACITY BTUH |        |        |        |        |        |         |         |         |
|-------------------------------|--------|--------|--------|--------|--------|---------|---------|---------|
| HTR KW                        | 3.0 KW | 4.7 KW | 6.0 KW | 7.0 KW | 9.5 KW | 14.2 KW | 19.5 KW | 21.0 KW |
| BTUH                          | 10200  | 16200  | 20400  | 23800  | 32400  | 48600   | 66500   | 71600   |

### FORMULAS:

Heating Output = KW x 3413 x Corr. Factor

Actual CFM = CFM (from table) x Corr. Factor

BTUH = KW x 3413

BTUH = CFM x 1.08 x Temperature Rise (T)

$$CFM = \frac{KW \times 3413}{1.08 \times T}$$

$$T = \frac{BTUH}{CFM \times 1.08}$$

## S-61A CHECKING HEATER LIMIT CONTROL(S)

Each individual heater element is protected with a limit control device connected in series with each element to prevent overheating of components in case of low airflow. This limit control will open its circuit at approximately 150°F.

| BTUH CAPACITY CORRECTION FACTOR |      |     |     |     |
|---------------------------------|------|-----|-----|-----|
| SUPPLY VOLTAGE                  | 250  | 230 | 220 | 208 |
| MULTIPLICATION FACTOR           | 1.08 | .92 | .84 | .75 |

**EXAMPLE:** Five (5) heaters provide 24.0 KW at the rated 240V. Our actual measured voltage is 220V, and our measured temperature rise is 42°F. Find the actual CFM:

**Answer:** 24.0KW, 42°F Rise, 240 V = 1800 CFM from the **TEMPERATURE RISE** chart on the right.

Heating output at 220 V = 24.0KW x 3.413 x .84 = 68.8 MBH.

Actual CFM = 1800 x .84 Corr. Factor = 1400 CFM.

# SERVICING

 **WARNING**  
**HIGH VOLTAGE!**  
Disconnect ALL power before servicing or installing. Multiple power sources may be present. Failure to do so may cause property damage, personal injury or death.



1. Remove the wiring from the control terminals.
2. Using an ohmmeter, test for continuity across the normally closed contacts. No reading indicates the control is open - replace if necessary.

IF FOUND OPEN - REPLACE - DO NOT WIRE AROUND.

## S-61B CHECKING HEATER FUSE LINK (OPTIONAL ELECTRIC HEATERS)

Each individual heater element is protected with a one time fuse link which is connected in series with the element. The fuse link will open at approximately 333°.

 **WARNING**  
Disconnect ALL power before servicing.

1. Remove heater element assembly so as to expose fuse link.
2. Using an ohmmeter, test across the fuse link for continuity - no reading indicates the link is open. Replace as necessary.

**NOTE:** The link is designed to open at approximately 333°F. DO NOT WIRE AROUND - determine reason for failure.

## S-62 CHECKING HEATER ELEMENTS

 **WARNING**  
Disconnect ALL power before servicing.

1. Disassemble and remove the heating element.
2. Visually inspect the heater assembly for any breaks in the wire or broken insulators.
3. Using an ohmmeter, test the element for continuity - no reading indicates the element is open. Replace as necessary.

## S-100 REFRIGERATION REPAIR PRACTICE

 **DANGER**  
Always remove the refrigerant charge in a proper manner before applying heat to the system.

When repairing the refrigeration system:

 **WARNING**  
**HIGH VOLTAGE!**  
Disconnect ALL power before servicing or installing. Multiple power sources may be present. Failure to do so may cause property damage, personal injury or death.



1. Never open a system that is under vacuum. Air and moisture will be drawn in.
2. Plug or cap all openings.
3. Remove all burrs and clean the brazing surfaces of the tubing with sand cloth or paper. Brazing materials do not flow well on oxidized or oily surfaces.
4. Clean the inside of all new tubing to remove oils and pipe chips.
5. When brazing, sweep the tubing with dry nitrogen to prevent the formation of oxides on the inside surfaces.
6. Complete any repair by replacing the liquid line drier in the system, evacuate and charge.

### **BRAZING MATERIALS**

**IMPORTANT NOTE:** Torch heat required to braze tubes of various sizes is proportional to the size of the tube. Tubes of smaller size require less heat to bring the tube to brazing temperature before adding brazing alloy. Applying too much heat to any tube can melt the tube. Service personnel must use the appropriate heat level for the size of the tube being brazed.

**NOTE:** The use of a heat shield when brazing is recommended to avoid burning the serial plate or the finish on the unit. Heat trap or wet rags should be used to protect heat sensitive components such as service valves and TXV valves.

**Copper to Copper Joints** - Sil-Fos used without flux (alloy of 15% silver, 80% copper, and 5% phosphorous). Recommended heat 1400°F.

**Copper to Steel Joints** - Silver Solder used without a flux (alloy of 30% silver, 38% copper, 32% zinc). Recommended heat - 1200°F.

# SERVICING

## S-101 LEAK TESTING (NITROGEN OR NITROGEN-TRACED)



### WARNING

To avoid the risk of fire or explosion, never use oxygen, high pressure air or flammable gases for leak testing of a refrigeration system.



### WARNING

To avoid possible explosion, the line from the nitrogen cylinder must include a pressure regulator and a pressure relief valve. The pressure relief valve must be set to open at no more than 150 psig.

Pressure test the system using dry nitrogen and soapy water to locate leaks. If you wish to use a leak detector, charge the system to 10 psi using the appropriate refrigerant then use nitrogen to finish charging the system to working pressure, then apply the detector to suspect areas. If leaks are found, repair them. After repair, repeat the pressure test. If no leaks exist, proceed to system evacuation.

## S-102 EVACUATION



### WARNING

**REFRIGERANT UNDER PRESSURE!**  
Failure to follow proper procedures may cause property damage, personal injury or death.

**IMPORTANT NOTE:** Because of the potential damage to compressors, do not allow suction pressure at service valve to drop below 20 PSIG when pumping unit system down for repair. Outdoor section, depending on line set length and amount of charge in system, may not be able to hold the entire system charge.

This is the most important part of the entire service procedure. The life and efficiency of the equipment is dependent upon the thoroughness exercised by the serviceman when evacuating air (non-condensables) and moisture from the system.

Air in a system causes high condensing temperature and pressure, resulting in increased power input and reduced performance.

Moisture chemically reacts with the refrigerant oil to form corrosive acids. These acids attack motor windings and parts, causing breakdown.

The equipment required to thoroughly evacuate the system is a high vacuum pump, capable of producing a vacuum equivalent to 25 microns absolute and a thermocouple vacuum gauge to give a true reading of the vacuum in the system

**NOTE:** Never use the system compressor as a vacuum pump or run when under a high vacuum. Motor damage could occur.



### WARNING

Do not front seat the service valve(s) with the compressor open, with the suction line of the compressor closed or severely restricted.

1. Connect the vacuum pump, vacuum tight manifold set with high vacuum hoses, thermocouple vacuum gauge and charging cylinder as shown.
2. Start the vacuum pump and open the shut off valve to the high vacuum gauge manifold only. After the compound gauge (low side) has dropped to approximately 29 inches of vacuum, open the valve to the vacuum thermocouple gauge. See that the vacuum pump will blank-off to a maximum of 25 microns. A high vacuum pump can only produce a good vacuum if its oil is non-contaminated.

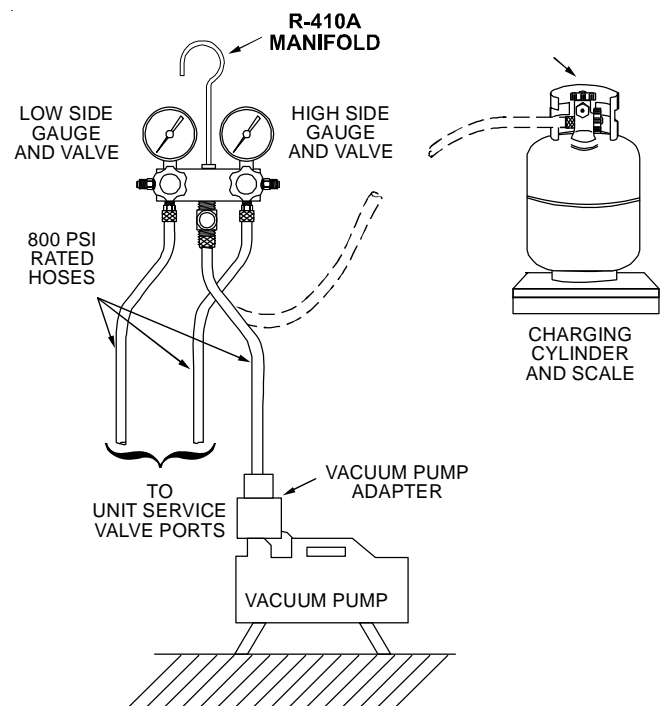

EVACUATION

3. If the vacuum pump is working properly, close the valve to the vacuum thermocouple gauge and open the high and low side valves to the high vacuum manifold set. With the valve on the charging cylinder closed, open the manifold valve to the cylinder.
4. Evacuate the system to at least 29 inches gauge before opening valve to thermocouple vacuum gauge.
5. Continue to evacuate to a maximum of 250 microns. Close valve to vacuum pump and watch rate of rise. If vacuum does not rise above 1500 microns in three to five minutes, system can be considered properly evacuated.
6. If thermocouple vacuum gauge continues to rise and levels off at about 5000 microns, moisture and non-condensables are still present. If gauge continues to rise a leak is present. Repair and re-evacuate.

# SERVICING

7. Close valve to thermocouple vacuum gauge and vacuum pump. Shut off pump and prepare to charge.

## S-103 CHARGING



### WARNING

#### REFRIGERANT UNDER PRESSURE!

- \* Do not overcharge system with refrigerant.
  - \* Do not operate unit in a vacuum or at negative pressure.
- Failure to follow proper procedures may cause property damage, personal injury or death.



### CAUTION

Use refrigerant certified to AHRI standards. Used refrigerant may cause compressor damage and will void the warranty. Most portable machines cannot clean used refrigerant to meet AHRI standards.



### CAUTION

Operating the compressor with the suction valve closed will void the warranty and cause serious compressor damage.

Charge the system with the exact amount of refrigerant.

Refer to the specification section or check the unit nameplates for the correct refrigerant charge.

***An inaccurately charged system will cause future problems.***

1. When using an ambient compensated calibrated charging cylinder, allow liquid refrigerant only to enter the high side.
2. After the system will take all it will take, close the valve on the high side of the charging manifold.
3. Start the system and charge the balance of the refrigerant through the low side.

NOTE: R410A should be drawn out of the storage container or drum in liquid form due to its fractionation properties, but should be "Flashed" to its gas state before entering the system. There are commercially available restriction devices that fit into the system charging hose set to accomplish this. **DO NOT** charge liquid R410A into the compressor.

4. With the system still running, close the valve on the charging cylinder. At this time, you may still have some liquid refrigerant in the charging cylinder hose and will definitely have liquid in the liquid hose. Reseat the liquid line core. Slowly open the high side manifold valve and transfer the liquid refrigerant from the liquid line hose and charging cylinder hose into the suction service valve port. CAREFUL: Watch so that liquid refrigerant does not enter the compressor.

## Final Charge Adjustment

The outdoor temperature must be 60°F or higher. Set the room thermostat to COOL, fan switch to AUTO, and set the temperature control well below room temperature.

After system has stabilized per startup instructions, compare the operating pressures and outdoor unit amp draw to the numbers listed on the performance label on the outdoor unit. If pressures and amp draw are too low, add charge. If pressures and amp draw are too high, remove charge. Check subcooling and superheat as detailed in the following section.

5. With the system still running, remove hose and reinstall both valve caps.
6. Check system for leaks.

Do not charge a remote condensing unit with a non-matching evaporator coil, or a system where the charge quantity is unknown. Do not install or charge R410A condensers matched with coils having capillary tubes or flow control restrictors. AHRI rated Coil combinations with thermostatic expansion valves (TEV's) should be charged by subcooling. See "Checking Subcooling and Superheat" sections in this manual. Subcooling values for "Ultron" system are found in the Technical Information manuals for "Ultron" outdoor units.

Due to their design, Scroll compressors are inherently more tolerant of liquid refrigerant.

**NOTE:** *Even though the compressor section of a Scroll compressor is more tolerant of liquid refrigerant, continued floodback or flooded start conditions may wash oil from the bearing surfaces causing premature bearing failure.*

## S-104 CHECKING COMPRESSOR EFFICIENCY

The reason for compressor inefficiency is broken or damaged scroll flanks on Scroll compressors, reducing the ability of the compressor to pump refrigerant vapor.

The condition of the scroll flanks is checked in the following manner.

1. Attach gauges to the high and low side of the system.
2. Start the system and run a "Cooling Performance Test.

If the test shows:

- a. Below normal high side pressure.
- b. Above normal low side pressure.
- c. Low temperature difference across coil.
- d. Low amp draw at compressor.

And the charge is correct. The compressor is faulty - replace the compressor.

# PISTON KIT CHART

# SERVICING

## S-105A PISTON CHART FOR

ASX13, ANX13, ANZ13, GSX13, VSX13, SSX14, ASX14, GSX14, ASZ13, GSZ13, GSZ14, VSZ13, SSZ14, ASX16, GSX16, ASZ16 UNITS

**WARNING**  
IT IS ESSENTIAL THAT INDOOR AND OUTDOOR UNITS BE PROPERLY MATCHED. FAILURE TO FOLLOW THESE INSTRUCTIONS OR TO PROPERLY MATCH EVAPORATORS AND CONDENSERS CAN RESULT IN UNIT DAMAGE, PROPERTY DAMAGE AND/OR PERSONAL INJURY. NO WARRANTY CLAIM WILL BE HONORED FOR MIX-MATCHED SYSTEMS THAT FAIL TO ADHERE TO THE SPECIFIED PISTON SIZE.

| Outdoor Unit                     |                                  | Indoor Unit |             | Indoor Piston Size | Piston Kit P/N       | Note   |
|----------------------------------|----------------------------------|-------------|-------------|--------------------|----------------------|--------|
| GSX130181(B,C,D,E)*<br>GSX130181 | ASX130181(B,C,D)*<br>ANX130181A* | WAC4318AC*  | WGAC4318AC* | 0.051              | B1789851             | 1      |
| GSX130241(B,C,D)*<br>GSX130241E* | ASX130241(B,C)*<br>VSX130241E*   | WAC4324AB*  | WGAC4324AB* | 0.051<br>0.057     | B1789851<br>B1789857 | 1<br>1 |
| GSX130241                        | ANX130241A*                      |             |             | 0.055              | B1789855             | 1      |
| GSX130242A*                      |                                  |             |             | 0.057              | B1789857             | 1      |
| GSX130301(B,D)*<br>GSX130301     | ASX130301(B,C)*<br>ANX130301A*   | WAC4330AB*  | WGAC4330AB* | 0.055<br>0.061     | B1789855<br>B1789861 | 1<br>1 |
| GSX130361(B,E)*<br>GSX130361     | ASX130361(B,C,D)*<br>ANX130361A* | WAC4336AB*  | WGAC4336AB* | 0.070<br>0.070     | B1789870<br>B1789870 | 1<br>1 |
| GSX130361D*                      | VSX130361D*                      |             |             | 0.067              | B1789867             | 1      |
| GSX130362A*                      |                                  |             |             | 0.065              | B1789865             | 1      |
| GSX130363A*                      |                                  |             |             | 0.070              | B1789870             | 1      |
| GSX130365A*                      |                                  |             |             | 0.065              | B1789865             | 1      |
| GSX130421B*                      | ASX130421(B,C)*<br>ANX130421A*   | WAC4342AB*  | WGAC4342AB* | 0.076<br>0.076     | B1789876<br>B1789876 | 1<br>1 |
| GSX130481B*                      | ASX130481(B,C)*<br>ANX130481A*   | WAC4348AB*  | WGAC4348AB* | 0.080<br>0.080     | B1789880<br>B1789880 | 1<br>1 |
| GSX130483A*                      |                                  |             |             | 0.080              | B1789880             | 1      |
| GSX130484A*                      |                                  |             |             | 0.080              | B1789880             | 1      |
| GSX130485A*                      |                                  |             |             | 0.076              | B1789876             | 1      |
| GSX130601B*                      | ASX130601(B,C)*<br>ANX130601A*   | WAC4360AB*  | WGAC4360AB* | 0.086<br>0.086     | B1789886<br>B1789886 | 1<br>1 |
| GSX130611A*                      | ASX130611A*<br>ANX130611A*       |             |             | 0.082<br>0.086     | B1789882<br>B1789886 | 2<br>1 |
| GSX130611                        |                                  |             |             | 0.086              | B1789886             | 1      |
| GSX130603A*                      |                                  |             |             | 0.086              | B1789886             | 1      |
| GSX130613A*                      |                                  |             |             | 0.082              | B1789882             | 2      |
| GSX130604A*                      |                                  |             |             | 0.086              | B1789886             | 1      |
| GSX130605A*                      |                                  |             |             | 0.086              | B1789886             | 1      |
| GSX130614A*                      |                                  |             |             | 0.082<br>0.086     | B1789882<br>B1789886 | 1<br>2 |

(\*) SIGNIFIES UNIT REVISION.  
 (1) CORRECT PISTON IS SUPPLIED WITH THE OUTDOOR UNIT.  
 (2) CORRECT PISTON IS SUPPLIED IN THE HIGHEST SALES VOLUME TESTED COMBINATION INDOOR UNIT. FOR ALL OTHER INDOOR COMBINATIONS, PISTON MUST BE PURCHASED FROM DISTRIBUTOR.  
 (3) TXV MUST BE PURCHASED SEPARATELY.

# SERVICING

## PISTON KIT CHART



**WARNING**  
IT IS ESSENTIAL THAT INDOOR AND OUTDOOR UNITS BE PROPERLY MATCHED. FAILURE TO FOLLOW THESE INSTRUCTIONS OR TO PROPERLY MATCH EVAPORATORS AND CONDENSERS CAN RESULT IN UNIT DAMAGE, PROPERTY DAMAGE AND/OR PERSONAL INJURY. NO WARRANTY CLAIM WILL BE HONORED FOR MIX-MATCHED SYSTEMS THAT FAIL TO ADHERE TO THE SPECIFIED PISTON SIZE.

|             |             | Outdoor Unit      |            |             | Indoor Unit                            |       | Indoor Piston Size | Piston Kit P/N | Note |
|-------------|-------------|-------------------|------------|-------------|--|-------|--------------------|----------------|------|
| GSX140181A* | SSX140181B* | ASX140181(B,C,D)* | WAC4418AB* | WGAC4418AB* | AWUF31 & 32<br>All other AHRI Matches  | 0.051 | B1789851           | 2              |      |
| GSX140241A* | SSX140241B* | ASX140241(B,C)*   | WAC4424AB* | WGAC4424AB* | AWUF 31<br>All Other AHRI Matches      | 0.052 | B1789852           | 1              |      |
| GSX140301A* | SSX140301B* | ASX140301(B,C)*   | WAC4430AB* | WGAC4430AB* | AWUF 31 & 32<br>All Other AHRI Matches | 0.055 | B1789855           | 2              |      |
| GSX140361A* | SSX140361B* | ASX140361(B,C)*   | WAC4436AB* | WGAC4436AB* | AWUF 31 & 32<br>All Other AHRI Matches | 0.061 | B1789861           | 2              |      |
| GSX140421A* | SSX140421C* | ASX140421(C,D)*   | WAC4442AC* | WGAC4442AC* | All AHRI Matches                       | 0.065 | B1789865           | 1              |      |
| GSX140481A* | SSX140481B* | ASX140481C*       | WAC4448AB* | WGAC4448AB* | All AHRI Matches                       | 0.068 | B1789868           | 1              |      |
| GSX140481A* | SSX140481A* | ASX140481B*       | WAC4448AA* | WGAC4448AA* | All AHRI Matches                       | 0.070 | B1789870           | 1              |      |
| GSX140601A* | SSX140601A* | ASX140601(A,B)*   | WAC4460AA* | WGAC4460AA* | All AHRI Matches                       | 0.078 | B1789878           | 1              |      |
| GSX140181K* | VSX140181A* | ASX140181K*       |            |             | All AHRI Matches                       | 0.079 | B1789879           | 1              |      |
| GSX140181K* | VSX140181A* | ASX140181K*       |            |             | All AHRI Matches                       | 0.088 | B1789888           | 1              |      |
| GSX140191K* | VSX140191A* | ASX140191K*       |            |             | AWUF 31 & 32<br>All other AHRI Matches | 0.051 | B1789851           | 2              |      |
| GSX140241K* | VSX140241A* | ASX140241K*       |            |             | AWUF 31 & 32<br>All other AHRI Matches | 0.051 | B1789851           | 2              |      |
| GSX140251K* | VSX140251A* | ASX140251K*       |            |             | AWUF 31 & 32<br>All other AHRI Matches | 0.052 | B1789852           | 1              |      |
| GSX140301K* | VSX140301A* | ASX140301K*       |            |             | AWUF 31 & 32<br>All other AHRI Matches | 0.051 | B1789851           | 2              |      |
| GSX140311K* | VSX140311A* | ASX140311K*       |            |             | AWUF 31 & 32<br>All other AHRI Matches | 0.051 | B1789851           | 2              |      |
| GSX140361K* | VSX140361A* | ASX140361K*       |            |             | AWUF 31 & 32<br>All other AHRI Matches | 0.051 | B1789851           | 2              |      |
| GSX140371K* | VSX140371A* | ASX140371K*       |            |             | AWUF 31 & 32<br>All other AHRI Matches | 0.053 | B1789853           | 1              |      |
| GSX140421K* | VSX140421A* | ASX140421K*       |            |             | AWUF 31 & 32<br>All other AHRI Matches | 0.051 | B1789851           | 2              |      |
| GSX140481K* | VSX140481A* | ASX140481K*       |            |             | AWUF 31 & 32<br>All other AHRI Matches | 0.051 | B1789851           | 2              |      |
| GSX140601K* | VSX140601A* | ASX140601K*       |            |             | AWUF 31 & 32<br>All other AHRI Matches | 0.053 | B1789853           | 1              |      |
| GSX140601K* | VSX140601A* | ASX140601K*       |            |             | AWUF 31 & 32<br>All other AHRI Matches | 0.057 | B1789857           | 1              |      |
| GSX140601K* | VSX140601A* | ASX140601K*       |            |             | AWUF 31 & 32<br>All other AHRI Matches | 0.057 | B1789857           | 1              |      |
| GSX140601K* | VSX140601A* | ASX140601K*       |            |             | AWUF 31 & 32<br>All other AHRI Matches | 0.061 | B1789861           | 2              |      |
| GSX140601K* | VSX140601A* | ASX140601K*       |            |             | AWUF 31 & 32<br>All other AHRI Matches | 0.061 | B1789861           | 2              |      |
| GSX140601K* | VSX140601A* | ASX140601K*       |            |             | AWUF 31 & 32<br>All other AHRI Matches | 0.065 | B1789865           | 1              |      |
| GSX140601K* | VSX140601A* | ASX140601K*       |            |             | AWUF 31 & 32<br>All other AHRI Matches | 0.065 | B1789865           | 1              |      |
| GSX140601K* | VSX140601A* | ASX140601K*       |            |             | AWUF 31 & 32<br>All other AHRI Matches | 0.061 | B1789861           | 2              |      |
| GSX140601K* | VSX140601A* | ASX140601K*       |            |             | AWUF 31 & 32<br>All other AHRI Matches | 0.063 | B1789863           | 1              |      |
| GSX140601K* | VSX140601A* | ASX140601K*       |            |             | AWUF 31 & 32<br>All other AHRI Matches | 0.061 | B1789861           | 2              |      |
| GSX140601K* | VSX140601A* | ASX140601K*       |            |             | AWUF 31 & 32<br>All other AHRI Matches | 0.068 | B1789868           | 1              |      |
| GSX140601K* | VSX140601A* | ASX140601K*       |            |             | AWUF 31 & 32<br>All other AHRI Matches | 0.068 | B1789868           | 1              |      |
| GSX140601K* | VSX140601A* | ASX140601K*       |            |             | AWUF 31 & 32<br>All other AHRI Matches | 0.071 | B1789871           | 1              |      |
| GSX140601K* | VSX140601A* | ASX140601K*       |            |             | AWUF 31 & 32<br>All other AHRI Matches | 0.071 | B1789871           | 1              |      |
| GSX140601K* | VSX140601A* | ASX140601K*       |            |             | AWUF 31 & 32<br>All other AHRI Matches | 0.074 | B1789874           | 1              |      |
| GSX140601K* | VSX140601A* | ASX140601K*       |            |             | AWUF 31 & 32<br>All other AHRI Matches | 0.074 | B1789874           | 1              |      |
| GSX140601K* | VSX140601A* | ASX140601K*       |            |             | AWUF 31 & 32<br>All other AHRI Matches | 0.078 | B1789878           | 1              |      |
| GSX140601K* | VSX140601A* | ASX140601K*       |            |             | AWUF 31 & 32<br>All other AHRI Matches | 0.078 | B1789878           | 1              |      |
| GSX140601K* | VSX140601A* | ASX140601K*       |            |             | AWUF 31 & 32<br>All other AHRI Matches | 0.088 | B1789888           | 1              |      |
| GSX140601K* | VSX140601A* | ASX140601K*       |            |             | AWUF 31 & 32<br>All other AHRI Matches | 0.088 | B1789888           | 1              |      |

(\*) SIGNIFIES UNIT REVISION.  
 (1) CORRECT PISTON IS SUPPLIED WITH THE OUTDOOR UNIT.  
 (2) CORRECT PISTON IS SUPPLIED IN THE HIGHEST SALES VOLUME TESTED COMBINATION INDOOR UNIT. FOR ALL OTHER INDOOR COMBINATIONS, PISTON MUST BE PURCHASED FROM DISTRIBUTOR.  
 (3) TXV MUST BE PURCHASED SEPARATELY.

**WARNING**  
 IT IS ESSENTIAL THAT INDOOR AND OUTDOOR UNITS BE PROPERLY MATCHED. FAILURE TO FOLLOW THESE INSTRUCTIONS OR TO PROPERLY MATCH EVAPORATORS AND CONDENSERS CAN RESULT IN UNIT DAMAGE, PROPERTY DAMAGE AND/OR PERSONAL INJURY. NO WARRANTY CLAIM WILL BE HONORED FOR MIX-MATCHED SYSTEMS THAT FAIL TO ADHERE TO THE SPECIFIED PISTON SIZE.

| Outdoor Unit     |                  | Indoor Unit      | Indoor Piston Size | Piston Kit P/N | Note |
|------------------|------------------|------------------|--------------------|----------------|------|
| GSX160181F*      | ASX160181**      | All AHRI Matches | TXV/only           | TXV-30         | 3    |
| GSX160241F*      | ASX160241**      | All AHRI Matches | TXV/only           | TXV-30         | 3    |
| GSX160301F*      | ASX160301**      | All AHRI Matches | TXV/only           | TXV-30         | 3    |
| GSX160361F*      | ASX160361**      | All AHRI Matches | TXV/only           | TXV-42         | 3    |
| GSX160421F*      | ASX160421**      | All AHRI Matches | TXV/only           | TXV-42         | 3    |
| GSX160481F*      | ASX160481**      | All AHRI Matches | TXV/only           | TXV-48         | 3    |
| GSX160601F*      | ASX160601**      | All AHRI Matches | TXV/only           | TXV-60         | 3    |
| GSX160181F*      | ASX160181F*      | All AHRI Matches | 0.049              | B1789849       | 1    |
| GSX160241F*      | ASX160241F*      | All AHRI Matches | 0.057              | B1789857       | 1    |
| GSX160301F*      | ASX160301F*      | All AHRI Matches | 0.065              | B1789865       | 1    |
| GSX160361F*      | ASX160361F*      | All AHRI Matches | 0.072              | B1789872       | 1    |
| GSX160421F*      | ASX160421F*      | All AHRI Matches | 0.074              | B1789874       | 1    |
| GSX160481F*      | ASX160481F*      | All AHRI Matches | 0.078              | B1789878       | 1    |
| GSX160601F*      | ASX160601F*      | All AHRI Matches | 0.086              | B1789886       | 1    |
| GSX160611F*      | ASX160611F*      | All AHRI Matches | TXV/only           | TXV-60         | 3    |
| GSX160611F*      | ASX160611F*      | All AHRI Matches | 0.088              | B1789888       | 1    |
| SSX160241B*      | WAC4624AB*       | All AHRI Matches | 0.055              | B1789855       | 1    |
| SSX160301A*      | WAC4630AA*       | All AHRI Matches | 0.062              | B1789862       | 1    |
| SSX160361(A,B)*  | WAC4636AB*       | All AHRI Matches | 0.068              | B1789868       | 1    |
| SSX160421A*      | WAC4642AA*       | All AHRI Matches | 0.070              | B1789870       | 1    |
| SSX160481(A,B)*  | WAC4648(A,B)*    | All AHRI Matches | 0.078              | B1789878       | 1    |
| SSX160591A*      | WAC4659AA*       | All AHRI Matches | TXV/only           | TX5N4          | 3    |
| SSX160601(A,B)*  | WGAC4660A*       | All AHRI Matches | TXV/only           | TX5N4          | 3    |
| DSXC160241A*     | ASXC160241B*     | All AHRI Matches | TXV/only           | TX2N4A         | 3    |
| DSXC160361A*     | ASXC160361B*     | All AHRI Matches | TXV/only           | TX3N4          | 3    |
| DSXC160481(A,B)* | ASXC160481(A,B)* | All AHRI Matches | TXV/only           | TX5N4          | 3    |
| DSXC160601(A,B)* | ASXC160601(A,B)* | All AHRI Matches | TXV/only           | TX5N4          | 3    |
| DSXC180361A*     | ASXC180361A*     | All AHRI Matches | TXV/only           | TX3N4          | 3    |
| DSXC180481A*     | ASXC180481A*     | All AHRI Matches | TXV/only           | TX5N4          | 3    |
| DSXC180601A*     | ASXC180601A*     | All AHRI Matches | TXV/only           | TX5N4          | 3    |

(\*) SIGNIFIES UNIT REVISION.

(1) CORRECT PISTON IS SUPPLIED WITH THE OUTDOOR UNIT.

(2) CORRECT PISTON IS SUPPLIED IN THE HIGHEST SALES VOLUME TESTED COMBINATION INDOOR UNIT. FOR ALL OTHER INDOOR COMBINATIONS, PISTON MUST BE PURCHASED FROM DISTRIBUTOR.  
 (3) TXV MUST BE PURCHASED SEPARATELY.



# SERVICING

## PISTON KIT CHART



### WARNING

IT IS ESSENTIAL THAT INDOOR AND OUTDOOR UNITS BE PROPERLY MATCHED. FAILURE TO FOLLOW THESE INSTRUCTIONS OR TO PROPERLY MATCH EVAPORATORS AND CONDENSERS CAN RESULT IN UNIT DAMAGE, PROPERTY DAMAGE AND/OR PERSONAL INJURY. NO WARRANTY CLAIM WILL BE HONORED FOR MIX-MATCHED SYSTEMS THAT FAIL TO ADHERE TO THE SPECIFIED PISTON SIZE.

| Outdoor Unit          |                 | Indoor Unit             | Indoor Piston Size | Piston Kit P/N | Note |
|-----------------------|-----------------|-------------------------|--------------------|----------------|------|
| GSC130181(B,D,F,G)*   |                 | All AHR I Matches       | 0.055              | B1789855       | 1    |
| GSC130241(D,E)*       |                 | All AHR I Matches       | 0.059              | B1789859       | 1    |
| GSC130241F*           |                 | All AHR I Matches       | 0.061              | B1789861       | 1    |
| GSC130301E*           |                 | All AHR I Matches       | 0.065              | B1789865       | 1    |
| GSC130361(A*,F*,G*)   |                 | All AHR I Matches       | 0.074              | B1789874       | 1    |
| GSC130363(A*, BA, BB) |                 | All AHR I Matches       | 0.074              | B1789874       | 1    |
| GSC130363B*           |                 | All AHR I Matches       | 0.071              | B1789871       | 1    |
| GSC130423(BA, BB)     |                 | All AHR I Matches       | 0.084              | B1789884       | 1    |
| GSC130421C*           |                 | All AHR I Matches       | 0.076              | B1789876       | 1    |
| GSC130481B*           |                 | All AHR I Matches       | 0.088              | B1789888       | 1    |
| GSC130481C*           |                 | All AHR I Matches       | 0.082              | B1789882       | 1    |
| GSC130483B*           |                 | All AHR I Matches       | 0.088              | B1789888       | 1    |
| GSC130483C*           |                 | All AHR I Matches       | 0.082              | B1789882       | 1    |
| GSC130484A*           |                 | All AHR I Matches       | 0.082              | B1789882       | 1    |
| GSC130484(BA, BB)     |                 | All AHR I Matches       | 0.088              | B1789888       | 1    |
| GSC130484B*           |                 | All AHR I Matches       | 0.082              | B1789882       | 1    |
| GSC130601C*           |                 | All AHR I Matches       | 0.093              | B1789893       | 1    |
| GSC130601D*           |                 | All AHR I Matches       | 0.090              | B1789890       | 1    |
| GSC130603B*           |                 | All AHR I Matches       | 0.093              | B1789893       | 1    |
| GSC130603C            |                 | All AHR I Matches       | 0.090              | B1789890       | 1    |
| GSC130604             |                 | All AHR I Matches       | 0.093              | B1789893       | 1    |
| GSC130604B*           |                 | All AHR I Matches       | 0.090              | B1789890       | 1    |
| GSZ130181A*           | VSZ130181A*     | WHP4318AA*              | 0.049              | B1789849       | 4    |
| GSZ130181A*           | VSZ130181A*     | All AHR I Matches       | 0.051              | B1789851       | 1    |
| GSZ130181             | ANZ130181A*     | All AHR I Matches       | 0.051              | B1789851       | 1    |
| GSZ130241(A,B)*       | VSZ130241B*     | WHP43241A               | 0.057              | B1789857       | 1    |
| GSZ130241             | ANZ130241(A,B)* | WGHP4324AA              | 0.057              | B1789857       | 1    |
| GSZ130301A*           | VSZ130301A*     | WHP43301A*              | 0.065              | B1789865       | 1    |
| GSZ130301AE           | VSZ130301AD     | All AHR I Matches       | 0.065              | B1789865       | 1    |
| GSZ130301             | ANZ130301A*     | All AHR I Matches       | 0.065              | B1789865       | 1    |
| GSZ130361B*           | VSZ130361B*     | ARUF36C                 | 0.071              | B1789871       | 2    |
| GSZ130361A*           | VSZ130361A*     | All AHR I Matches       | 0.070              | B1789870       | 1    |
| GSZ130361A*           | VSZ130361A*     | ARUF36C                 | 0.071              | B1789871       | 2    |
| GSZ130361A*           | VSZ130361A*     | AR*F3636                | 0.070              | B1789870       | 2    |
| GSZ130361A*           | VSZ130361A*     | All Other AHR I Matches | 0.068              | B1789868       | 1    |
| GSZ130361             | ANZ130361A*     | ARUF36C                 | 0.071              | B1789871       | 2    |
| GSZ130361             | ANZ130361A*     | AR*F3636                | 0.070              | B1789870       | 2    |
| GSZ130361             | ANZ130361A*     | All Other AHR I Matches | 0.068              | B1789868       | 1    |

(\*) SIGNIFIES UNIT REVISION.

(1) CORRECT PISTON IS SUPPLIED WITH THE OUTDOOR UNIT.

(2) CORRECT PISTON IS SUPPLIED IN THE HIGHEST SALES VOLUME TESTED COMBINATION INDOOR UNIT. FOR ALL OTHER INDOOR COMBINATIONS, PISTON MUST BE PURCHASED FROM DISTRIBUTOR.

(3) TXV MUST BE PURCHASED SEPARATELY.

# SERVICING

## PISTON KIT CHART

**WARNING**  IT IS ESSENTIAL THAT INDOOR AND OUTDOOR UNITS BE PROPERLY MATCHED. FAILURE TO FOLLOW THESE INSTRUCTIONS OR TO PROPERLY MATCH EVAPORATORS AND CONDENSERS CAN RESULT IN UNIT DAMAGE, PROPERTY DAMAGE AND/OR PERSONAL INJURY. NO WARRANTY CLAIM WILL BE HONORED FOR MIX-MATCHED SYSTEMS THAT FAIL TO ADHERE TO THE SPECIFIED PISTON SIZE.

| Outdoor Unit     |             | Indoor Unit | Indoor Piston Size | Piston Kit P/N         | Note       |
|------------------|-------------|-------------|--------------------|------------------------|------------|
| GSZ130363A*      |             |             |                    | AR*F3636               | B1789870 2 |
| GSZ130421A*      | VSZ130421A* | WHP4342AA*  | 0.070              | All Other AHRI Matches | B1789868 1 |
| GSZ130421A*      | VSZ130421A* |             | 0.068              |                        |            |
| GSZ130421A*      | VSZ130421A* |             | 0.074              | All AHRI Matches       | B1789874 6 |
| GSZ130421        | ANZ130421A* |             | 0.072              | All AHRI Matches       | B1789872 1 |
| GSZ130481A*      | VSZ130481A* | WHP4348AA*  | 0.072              |                        | B1789872 1 |
| GSZ130481A*      | VSZ130481A* |             | 0.078              | All AHRI Matches       | B1789878 1 |
| GSZ130481        | ANZ130481A* |             | 0.078              |                        | B1789878 1 |
| GSZ130483A*      |             |             | 0.078              | All AHRI Matches       | B1789878 1 |
| GSZ130484A*      |             |             | 0.078              | All AHRI Matches       | B1789878 1 |
| GSZ130601A*      | VSZ130601A* | WHP4360AA*  | 0.086              | All AHRI Matches       | B1789886 1 |
| GSZ130601        | ANZ130601A* |             | 0.088              | C HPF4860D6D*          | B1789886 1 |
| GSZ130603A*      |             |             | 0.088              | All Other AHRI Matches | B1789888 1 |
| GSZ130604A*      |             |             | 0.088              |                        | B1789888 1 |
|                  |             |             | 0.082              | ASUF49                 | B1789882 2 |
|                  |             |             | 0.086              | CHPF4860D6D*           | B1789886 1 |
|                  |             |             | 0.088              | All Other AHRI Matches | B1789888 1 |
|                  |             |             | 0.082              | ASUF49                 | B1789882 2 |
|                  |             |             | 0.086              | CHPF4860D6D*           | B1789886 1 |
|                  |             |             | 0.088              | All Other AHRI Matches | B1789888 1 |
| GSH130181(B,C)*  |             |             | 0.055              | All AHRI Matches       | B1789855 1 |
| GSH130241(B,C)*  |             |             | 0.061              | All AHRI Matches       | B1789861 1 |
| GSH130301(B,C)*  |             |             | 0.070              | All AHRI Matches       | B1789870 1 |
| GSH130361(A, B)* |             |             | 0.073              | All AHRI Matches       | B1789873 1 |
| GSH130361(CA/CB) |             |             | 0.073              | All AHRI Matches       | B1789873 1 |
| GSH130361 C*     |             |             | 0.071              | All AHRI Matches       | B1789871 1 |
| GSH130363(AA-AE) |             |             | 0.073              | All AHRI Matches       | B1789873 1 |
| GSH130363A*      |             |             | 0.071              | All AHRI Matches       | B1789871 1 |
| GSH130421A*      |             |             | 0.082              | All AHRI Matches       | B1789882 1 |
| GSH130421B*      |             |             | 0.080              | All AHRI Matches       | B1789880 1 |
| GSH130481(A, B)* |             |             | 0.084              | All AHRI Matches       | B1789884 1 |
| GSH130483(A, B)* |             |             | 0.084              | All AHRI Matches       | B1789884 1 |
| GSH130484A*      |             |             | 0.084              | All AHRI Matches       | B1789884 1 |
| GSH130601A*      |             |             | 0.093              | All AHRI Matches       | B1789893 1 |
| GSH130603A*      |             |             | 0.093              | All AHRI Matches       | B1789893 1 |
| GSH130604A*      |             |             | 0.093              | All AHRI Matches       | B1789893 1 |

(\*) SIGNIFIES UNIT REVISION.

(1) CORRECT PISTON IS SUPPLIED WITH THE OUTDOOR UNIT.

(2) CORRECT PISTON IS SUPPLIED IN THE HIGHEST SALES VOLUME TESTED COMBINATION INDOOR UNIT. FOR ALL OTHER INDOOR COMBINATIONS, PISTON MUST BE PURCHASED FROM DISTRIBUTOR.

(3) TXV MUST BE PURCHASED SEPARATELY.

# SERVICING

## PISTON KIT CHART



### WARNING

IT IS ESSENTIAL THAT INDOOR AND OUTDOOR UNITS BE PROPERLY MATCHED. FAILURE TO FOLLOW THESE INSTRUCTIONS OR TO PROPERLY MATCH EVAPORATORS AND CONDENSERS CAN RESULT IN UNIT DAMAGE, PROPERTY DAMAGE AND/OR PERSONAL INJURY. NO WARRANTY CLAIM WILL BE HONORED FOR MIX-MATCHED SYSTEMS THAT FAIL TO ADHERE TO THE SPECIFIED PISTON SIZE.

| Outdoor Unit |             | Indoor Unit | Indoor Piston Size | Piston Kit P/N | Note |
|--------------|-------------|-------------|--------------------|----------------|------|
| GSZ140181K*  | VSZ140181A* | ASZ140181K* | TXV/only           | TX2N4A         | 3    |
|              |             | ANZ140181A* | TXV/only           | TX2N4A         | 3    |
| GSZ140241K*  | VSZ140241A* | ASZ140241K* | TXV/only           | TX2N4A         | 3    |
|              |             | ANZ140241A* | TXV/only           | TX2N4A         | 3    |
| GSZ140301K*  | VSZ140301A* | ASZ140301K* | TXV/only           | TX2N4A         | 3    |
|              |             | ANZ140301A* | TXV/only           | TX2N4A         | 3    |
| GSZ140361K*  | VSZ140361A* | ASZ140361K* | TXV/only           | TX3N4          | 3    |
|              |             | ANZ140361A* | TXV/only           | TX3N4          | 3    |
| GSZ140421K*  | VSZ140421A* | ASZ140421K* | TXV/only           | TX3N4          | 3    |
|              |             | ANZ140421A* | TXV/only           | TX3N4          | 3    |
| GSZ140481K*  | VSZ140481A* | ASZ140481K* | TXV/only           | TX5N4          | 3    |
|              |             | ANZ140481A* | TXV/only           | TX5N4          | 3    |
| GSZ140491K*  | VSZ140491A* | ASZ140491K* | TXV/only           | TX5N4          | 3    |
|              |             | ANZ140491A* | TXV/only           | TX5N4          | 3    |
| GSZ140601K*  | VSZ140601A* | ASZ140601K* | TXV/only           | TXV-61         | 3    |
|              |             | ANZ140601A* | TXV/only           | TXV-61         | 3    |
| GSZ140181K*  | VSZ140181A* | ASZ140181K* | 0.051              | B1789851       | 2    |
|              |             | ANZ140181A* | 0.051              | B1789851       | 2    |
| GSZ140241K*  | VSZ140241A* | ASZ140241K* | 0.059              | B1789859       | 2    |
|              |             | ANZ140241A* | 0.059              | B1789859       | 2    |
| GSZ140301K*  | VSZ140301A* | ASZ140301K* | 0.065              | B1789865       | 2    |
|              |             | ANZ140301A* | 0.065              | B1789865       | 2    |
| GSZ140361K*  | VSZ140361A* | ASZ140361K* | 0.072              | B1789872       | 2    |
|              |             | ANZ140361A* | 0.072              | B1789872       | 2    |
| GSZ140421K*  | VSZ140421A* | ASZ140421K* | 0.078              | B1789878       | 2    |
|              |             | ANZ140421A* | 0.078              | B1789878       | 2    |
| GSZ140481K*  | VSZ140481A* | ASZ140481K* | 0.080              | B1789880       | 2    |
|              |             | ANZ140481A* | 0.080              | B1789880       | 2    |
| GSZ140491K*  | VSZ140491A* | ASZ140491K* | 0.080              | B1789880       | 2    |
|              |             | ANZ140491A* | 0.080              | B1789880       | 2    |

(\*) SIGNIFIES UNIT REVISION.

(1) CORRECT PISTON IS SUPPLIED WITH THE OUTDOOR UNIT.

(2) CORRECT PISTON IS SUPPLIED IN THE HIGHEST SALES VOLUME TESTED COMBINATION INDOOR UNIT. FOR ALL OTHER INDOOR COMBINATIONS, PISTON MUST BE PURCHASED FROM DISTRIBUTOR.

(3) TXV/MUST BE PURCHASED SEPARATELY.

# PISTON KIT CHART



## WARNING

IT IS ESSENTIAL THAT INDOOR AND OUTDOOR UNITS BE PROPERLY MATCHED. FAILURE TO FOLLOW THESE INSTRUCTIONS OR TO PROPERLY MATCH EVAPORATORS AND CONDENSERS CAN RESULT IN UNIT DAMAGE, PROPERTY DAMAGE AND/OR PERSONAL INJURY. NO WARRANTY CLAIM WILL BE HONORED FOR MIX-MATCHED SYSTEMS THAT FAIL TO ADHERE TO THE SPECIFIED PISTON SIZE.

# SERVICING

| Outdoor Unit     |                  | Indoor Unit                            | Indoor Piston Size | Piston Kit P/N     | Note   |
|------------------|------------------|--|--------------------|--------------------|--------|
| SSZ140181A*      |                  | AWUF31<br>All AHRI Matches             | 0.051<br>TXV only  | B1789851<br>TX2N4A | 2<br>3 |
| SSZ140241A*      |                  | AWUF 31 & 32<br>All Other AHRI Matches | 0.057<br>TXV only  | B1789857<br>TX2N4A | 2<br>3 |
| SSZ140301A*      |                  | AWUF 31 & 32<br>All Other AHRI Matches | 0.065<br>TXV only  | B1789865<br>TX3N4  | 2<br>3 |
| SSZ140361(A,B)*  |                  | All AHRI Matches                       | 0.071              | B1789871           | 2      |
| SSZ140381A*      |                  | All AHRI Matches                       | 0.070              | B178970            | 1      |
| SSZ140381A*      | ASZ140381A*      | All AHRI Matches                       | TXV only           | TX3N4              | 3      |
| SSZ140421A*      |                  | All AHRI Matches                       | 0.076              | B1789876           | 2      |
| SSZ140481A*      |                  | All AHRI Matches                       | 0.082              | B1789882           | 2      |
| SSZ140601A*      |                  | All AHRI Matches                       | 0.088              | B1789888           | 2      |
| SSZ160241A*      | ASZ160241(A,K)*  | All AHRI Matches                       | TXV only           | TX2N4A             | 3      |
| SSZ160361A*      | ASZ160361(A,K)*  | All AHRI Matches                       | TXV only           | TX3N4              | 3      |
| SSZ160481A*      | ASZ160481(A,K)*  | All AHRI Matches                       | TXV only           | TX5N4              | 3      |
| SSZ160601(A,B)*  | ASZ160601(A,K)*  | All AHRI Matches                       | TXV only           | TX5N4              | 3      |
| SSZ160601(A,B)*  | ASZ160601(A,B)*  | All AHRI Matches                       | TXV only           | TX5N4              | 3      |
| DSZC160241A*     | ASZC160241A*     | WGHP4624AA*                            | TXV only           | TX2N4A             | 3      |
| DSZC160361A*     | ASZC160361A*     | WGHP4636AA*                            | TXV only           | TX3N4              | 3      |
| DSZC160481A*     | ASZC160481A*     | WGHP4648AA*                            | TXV only           | TX5N4              | 3      |
| DSZC160601(A,B)* | ASZC160601(A,B)* | WGHP4660AB*                            | TXV only           | TX5N4              | 3      |
| DSZC180361A*     | ASZC180361A*     | WGHP4836AA*                            | TXV only           | TX3N4              | 3      |
| DSZC180481A*     | ASZC180481A*     | WGHP4848AA*                            | TXV only           | TX5N4              | 3      |
| DSZC180601(A,B)* | ASZC180601(A,B)* | WGHP4860AB*                            | TXV only           | TX5N4              | 3      |

| Outdoor Unit |  | Indoor Unit      | Indoor Piston Size | Piston Kit P/N | Note |
|--------------|--|------------------|--------------------|----------------|------|
| CKL36-1P*    |  | All AHRI Matches | 0.071              | B1789871       | 1    |
| CKL49-1P*    |  | All AHRI Matches | 0.080              | B1789880       | 1    |
| CKL60-1P*    |  | All AHRI Matches | 0.093              | B1789893       | 1    |
| CK60-3P*     |  | All AHRI Matches | 0.093              | B1789893       | 1    |
| CKF36-2P*    |  | All AHRI Matches | 0.068              | B1789868       | 1    |
| CKF36-5P*    |  | All AHRI Matches | 0.068              | B1789868       | 1    |
| CKF48-5P*    |  | All AHRI Matches | 0.080              | B1789880       | 1    |
| CKF60-5P*    |  | All AHRI Matches | 0.093              | B1789893       | 1    |
| CPKF36-2P*   |  | All AHRI Matches | 0.073              | B1789873       | 1    |
| CPKF36-5P*   |  | All AHRI Matches | 0.073              | B1789873       | 1    |
| CPKF48-5P*   |  | All AHRI Matches | 0.084              | B1789884       | 1    |
| CPKF60-5N*   |  | All AHRI Matches | 0.093              | B1789893       | 1    |
| CPKF60-5P*   |  | All AHRI Matches | 0.093              | B1789893       | 1    |
| CPKF61-5N*   |  | All AHRI Matches | 0.093              | B1789893       | 1    |
| CPKF61-5P*   |  | All AHRI Matches | 0.093              | B1789893       | 1    |

(\*) SIGNIFIES UNIT REVISION.

(1) CORRECT PISTON IS SUPPLIED WITH THE OUTDOOR UNIT.

(2) CORRECT PISTON IS SUPPLIED IN THE HIGHEST SALES VOLUME TESTED COMBINATION INDOOR UNIT. FOR ALL OTHER INDOOR COMBINATIONS, PISTON MUST BE PURCHASED FROM DISTRIBUTOR.

(3) TXV MUST BE PURCHASED SEPARATELY.

# SERVICING

## S-105B THERMOSTATIC EXPANSION VALVE

The expansion valve is designed to control the rate of liquid refrigerant flow into an evaporator coil in exact proportion to the rate of evaporation of the refrigerant in the coil. The amount of refrigerant entering the coil is regulated since the valve responds to temperature of the refrigerant gas leaving the coil (feeler bulb contact) and the pressure of the refrigerant in the coil. This regulation of the flow prevents the return of liquid refrigerant to the compressor.

The illustration below shows typical heatpump TXV/check valve operation in the heating and cooling modes.

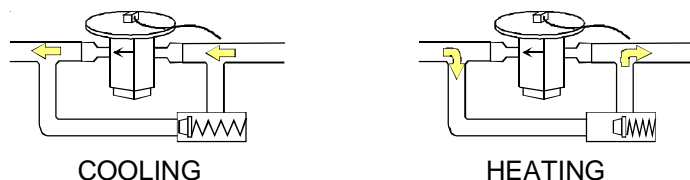

### TXV VALVES

Some TXV valves contain an internal check valve thus eliminating the need for an external check valve and bypass loop. The three forces which govern the operation of the valve are: (1) the pressure created in the power assembly by the feeler bulb, (2) evaporator pressure, and (3) the equivalent pressure of the superheat spring in the valve.

0% bleed type expansion valves are used on indoor and outdoor coils. The 0% bleed valve will not allow the system pressures (High and Low side) to equalize during the shut down period. The valve will shut off completely at approximately 100 PSIG.

30% bleed valves used on some other models will continue to allow some equalization even though the valve has shut-off completely because of the bleed holes within the valve. This type of valve should not be used as a replacement for a 0% bleed valve, due to the resulting drop in performance.

The bulb must be securely fastened with two straps to a clean straight section of the suction line. Application of the bulb to a horizontal run of line is preferred. If a vertical installation cannot be avoided, the bulb must be mounted so that the capillary tubing comes out at the top.

**THE VALVES PROVIDED BY GOODMAN ARE DESIGNED TO MEET THE SPECIFICATION REQUIREMENTS FOR OPTIMUM PRODUCT OPERATION. DO NOT USE SUBSTITUTES.**

## S-106 OVERFEEDING

Overfeeding by the expansion valve results in high suction pressure, cold suction line, and possible liquid slugging of the compressor.

If these symptoms are observed:

1. Check for an overcharged unit by referring to the cooling performance charts in the servicing section.
2. Check the operation of the power element in the valve as explained in S-110 Checking Expansion Valve Operation.
3. Check for restricted or plugged equalizer tube.

## S-107 UNDERFEEDING

Underfeeding by the expansion valve results in low system capacity and low suction pressures.

If these symptoms are observed:

1. Check for a restricted liquid line or drier. A restriction will be indicated by a temperature drop across the drier.
2. Check the operation of the power element of the valve as described in S-110 Checking Expansion Valve Operation.

## S-108 SUPERHEAT

The expansion valves are factory adjusted to maintain 8 to 12 degrees superheat of the suction gas. Before checking the superheat or replacing the valve, perform all the procedures outlined under Air Flow, Refrigerant Charge, Expansion Valve - Overfeeding, Underfeeding. These are the most common causes for evaporator malfunction.

### CHECKING SUPERHEAT

Refrigerant gas is considered superheated when its temperature is higher than the saturation temperature corresponding to its pressure. The degree of superheat equals the degrees of temperature increase above the saturation temperature at existing pressure. See Temperature - Pressure Chart on following pages.



### CAUTION

**To prevent personal injury, carefully connect and disconnect manifold gauge hoses. Escaping liquid refrigerant can cause burns. Do not vent refrigerant to atmosphere. Recover during system repair or final unit disposal.**

1. Run system at least 10 minutes to allow pressure to stabilize.
2. For best results, temporarily install a thermometer on the liquid line at the liquid line service valve and 4-6" from the compressor on the suction line. Ensure the thermometer makes adequate contact and is insulated for best possible readings. Use liquid line temperature to determine sub-cooling and vapor temperature to determine superheat.

NOTE: An optional method is to locate the thermometer at the suction line service valve. Ensure the thermometer makes adequate contact and is insulated for best possible readings.

3. Refer to the superheat table provided for proper system superheat. Add charge to lower superheat or recover charge to raise superheat.

Superheat Formula = Suct. Line Temp. - Sat. Suct. Temp.

### EXAMPLE:

- a. Suction Pressure = 143
- b. Corresponding Temp. °F. = 50
- c. Thermometer on Suction Line = 61°F.

# SERVICING

| Pressure vs. Temperature Chart |       |       |      |       |      |       |       |       |       |       |       |      |    |
|--------------------------------|-------|-------|------|-------|------|-------|-------|-------|-------|-------|-------|------|----|
| R-410A                         |       |       |      |       |      |       |       |       |       |       |       |      |    |
| PSIG                           | °F    | PSIG  | °F   | PSIG  | °F   | PSIG  | °F    | PSIG  | °F    | PSIG  | °F    | PSIG | °F |
| 12                             | -37.7 | 114.0 | 37.8 | 216.0 | 74.3 | 318.0 | 100.2 | 420.0 | 120.7 | 522.0 | 137.6 |      |    |
| 14                             | -34.7 | 116.0 | 38.7 | 218.0 | 74.9 | 320.0 | 100.7 | 422.0 | 121.0 | 524.0 | 137.9 |      |    |
| 16                             | -32.0 | 118.0 | 39.5 | 220.0 | 75.5 | 322.0 | 101.1 | 424.0 | 121.4 | 526.0 | 138.3 |      |    |
| 18                             | -29.4 | 120.0 | 40.5 | 222.0 | 76.1 | 324.0 | 101.6 | 426.0 | 121.7 | 528.0 | 138.6 |      |    |
| 20                             | -36.9 | 122.0 | 41.3 | 224.0 | 76.7 | 326.0 | 102.0 | 428.0 | 122.1 | 530.0 | 138.9 |      |    |
| 22                             | -24.5 | 124.0 | 42.2 | 226.0 | 77.2 | 328.0 | 102.4 | 430.0 | 122.5 | 532.0 | 139.2 |      |    |
| 24                             | -22.2 | 126.0 | 43.0 | 228.0 | 77.8 | 330.0 | 102.9 | 432.0 | 122.8 | 534.0 | 139.5 |      |    |
| 26                             | -20.0 | 128.0 | 43.8 | 230.0 | 78.4 | 332.0 | 103.3 | 434.0 | 123.2 | 536.0 | 139.8 |      |    |
| 28                             | -17.9 | 130.0 | 44.7 | 232.0 | 78.9 | 334.0 | 103.7 | 436.0 | 123.5 | 538.0 | 140.1 |      |    |
| 30                             | -15.8 | 132.0 | 45.5 | 234.0 | 79.5 | 336.0 | 104.2 | 438.0 | 123.9 | 540.0 | 140.4 |      |    |
| 32                             | -13.8 | 134.0 | 46.3 | 236.0 | 80.0 | 338.0 | 104.6 | 440.0 | 124.2 | 544.0 | 141.0 |      |    |
| 34                             | -11.9 | 136.0 | 47.1 | 238.0 | 80.6 | 340.0 | 105.1 | 442.0 | 124.6 | 548.0 | 141.6 |      |    |
| 36                             | -10.1 | 138.0 | 47.9 | 240.0 | 81.1 | 342.0 | 105.4 | 444.0 | 124.9 | 552.0 | 142.1 |      |    |
| 38                             | -8.3  | 140.0 | 48.7 | 242.0 | 81.6 | 344.0 | 105.8 | 446.0 | 125.3 | 556.0 | 142.7 |      |    |
| 40                             | -6.5  | 142.0 | 49.5 | 244.0 | 82.2 | 346.0 | 106.3 | 448.0 | 125.6 | 560.0 | 143.3 |      |    |
| 42                             | -4.5  | 144.0 | 50.3 | 246.0 | 82.7 | 348.0 | 106.6 | 450.0 | 126.0 | 564.0 | 143.9 |      |    |
| 44                             | -3.2  | 146.0 | 51.1 | 248.0 | 83.3 | 350.0 | 107.1 | 452.0 | 126.3 | 568.0 | 144.5 |      |    |
| 46                             | -1.6  | 148.0 | 51.8 | 250.0 | 83.8 | 352.0 | 107.5 | 454.0 | 126.6 | 572.0 | 145.0 |      |    |
| 48                             | 0.0   | 150.0 | 52.5 | 252.0 | 84.3 | 354.0 | 107.9 | 456.0 | 127.0 | 576.0 | 145.6 |      |    |
| 50                             | 1.5   | 152.0 | 53.3 | 254.0 | 84.8 | 356.0 | 108.3 | 458.0 | 127.3 | 580.0 | 146.2 |      |    |
| 52                             | 3.0   | 154.0 | 54.0 | 256.0 | 85.4 | 358.0 | 108.8 | 460.0 | 127.7 | 584.0 | 146.7 |      |    |
| 54                             | 4.5   | 156.0 | 54.8 | 258.0 | 85.9 | 360.0 | 109.2 | 462.0 | 128.0 | 588.0 | 147.3 |      |    |
| 56                             | 5.9   | 158.0 | 55.5 | 260.0 | 86.4 | 362.0 | 109.6 | 464.0 | 128.3 | 592.0 | 147.9 |      |    |
| 58                             | 7.3   | 160.0 | 56.2 | 262.0 | 86.9 | 364.0 | 110.0 | 466.0 | 128.7 | 596.0 | 148.4 |      |    |
| 60                             | 8.6   | 162.0 | 57.0 | 264.0 | 87.4 | 366.0 | 110.4 | 468.0 | 129.0 | 600.0 | 149.0 |      |    |
| 62                             | 10.0  | 164.0 | 57.7 | 266.0 | 87.9 | 368.0 | 110.8 | 470.0 | 129.3 | 604.0 | 149.5 |      |    |
| 64                             | 11.3  | 166.0 | 58.4 | 268.0 | 88.4 | 370.0 | 111.2 | 472.0 | 129.7 | 608.0 | 150.1 |      |    |
| 66                             | 12.6  | 168.0 | 59.0 | 270.0 | 88.9 | 372.0 | 111.6 | 474.0 | 130.0 | 612.0 | 150.6 |      |    |
| 68                             | 13.8  | 170.0 | 59.8 | 272.0 | 89.4 | 374.0 | 112.0 | 476.0 | 130.3 | 616.0 | 151.2 |      |    |
| 70                             | 15.1  | 172.0 | 60.5 | 274.0 | 89.9 | 376.0 | 112.4 | 478.0 | 130.7 | 620.0 | 151.7 |      |    |
| 72                             | 16.3  | 174.0 | 61.1 | 276.0 | 90.4 | 378.0 | 112.6 | 480.0 | 131.0 | 624.0 | 152.3 |      |    |
| 74                             | 17.5  | 176.0 | 61.8 | 278.0 | 90.9 | 380.0 | 113.1 | 482.0 | 131.3 | 628.0 | 152.8 |      |    |
| 76                             | 18.7  | 178.0 | 62.5 | 280.0 | 91.4 | 382.0 | 113.5 | 484.0 | 131.6 | 632.0 | 153.4 |      |    |
| 78                             | 19.8  | 180.0 | 63.1 | 282.0 | 91.9 | 384.0 | 113.9 | 486.0 | 132.0 | 636.0 | 153.9 |      |    |
| 80                             | 21.0  | 182.0 | 63.8 | 284.0 | 92.4 | 386.0 | 114.3 | 488.0 | 132.3 | 640.0 | 154.5 |      |    |
| 82                             | 22.1  | 184.0 | 64.5 | 286.0 | 92.8 | 388.0 | 114.7 | 490.0 | 132.6 | 644.0 | 155.0 |      |    |
| 84                             | 23.2  | 186.0 | 65.1 | 288.0 | 93.3 | 390.0 | 115.0 | 492.0 | 132.9 | 648.0 | 155.5 |      |    |
| 86                             | 24.3  | 188.0 | 65.8 | 290.0 | 93.8 | 392.0 | 115.5 | 494.0 | 133.3 | 652.0 | 156.1 |      |    |
| 88                             | 25.4  | 190.0 | 66.4 | 292.0 | 94.3 | 394.0 | 115.8 | 496.0 | 133.6 | 656.0 | 156.6 |      |    |
| 90                             | 26.4  | 192.0 | 67.0 | 294.0 | 94.8 | 396.0 | 116.2 | 498.0 | 133.9 | 660.0 | 157.1 |      |    |
| 92                             | 27.4  | 194.0 | 67.7 | 296.0 | 95.2 | 398.0 | 116.6 | 500.0 | 134.0 | 664.0 | 157.7 |      |    |
| 94                             | 28.5  | 196.0 | 68.3 | 298.0 | 95.7 | 400.0 | 117.0 | 502.0 | 134.5 | 668.0 | 158.2 |      |    |
| 96                             | 29.5  | 198.0 | 68.9 | 300.0 | 96.2 | 402.0 | 117.3 | 504.0 | 134.8 | 672.0 | 158.7 |      |    |
| 98                             | 30.5  | 200.0 | 69.5 | 302.0 | 96.6 | 404.0 | 117.7 | 506.0 | 135.2 | 676.0 | 159.2 |      |    |
| 100                            | 31.2  | 202.0 | 70.1 | 304.0 | 97.1 | 406.0 | 118.1 | 508.0 | 135.5 | 680.0 | 159.8 |      |    |
| 102                            | 32.2  | 204.0 | 70.7 | 306.0 | 97.5 | 408.0 | 118.5 | 510.0 | 135.8 | 684.0 | 160.3 |      |    |
| 104                            | 33.2  | 206.0 | 71.4 | 308.0 | 98.0 | 410.0 | 118.8 | 512.0 | 136.1 | 688.0 | 160.8 |      |    |
| 106                            | 34.1  | 208.0 | 72.0 | 310.0 | 98.4 | 412.0 | 119.2 | 514.0 | 136.4 | 692.0 | 161.3 |      |    |
| 108                            | 35.1  | 210.0 | 72.6 | 312.0 | 98.9 | 414.0 | 119.6 | 516.0 | 136.7 | 696.0 | 161.8 |      |    |
| 110                            | 35.5  | 212.0 | 73.2 | 314.0 | 99.3 | 416.0 | 119.9 | 518.0 | 137.0 |       |       |      |    |
| 112                            | 36.9  | 214.0 | 73.8 | 316.0 | 99.7 | 418.0 | 120.3 | 520.0 | 137.3 |       |       |      |    |

\*Based on ALLIED SIGNAL Data

# SERVICING

| REQUIRED LIQUID LINE TEMPERATURE           |                                      |     |     |     |     |     |
|--|--------------------------------------|-----|-----|-----|-----|-----|
| LIQUID PRESSURE<br>AT SERVICE VALVE (PSIG) | REQUIRED SUBCOOLING TEMPERATURE (°F) |     |     |     |     |     |
|  | 8                                    | 10  | 12  | 14  | 16  | 18  |
| 189  | 58                                   | 56  | 54  | 52  | 50  | 48  |
| 195  | 60                                   | 58  | 56  | 54  | 52  | 50  |
| 202  | 62                                   | 60  | 58  | 56  | 54  | 52  |
| 208  | 64                                   | 62  | 60  | 58  | 56  | 54  |
| 215  | 66                                   | 64  | 62  | 60  | 58  | 56  |
| 222  | 68                                   | 66  | 64  | 62  | 60  | 58  |
| 229  | 70                                   | 68  | 66  | 64  | 62  | 60  |
| 236  | 72                                   | 70  | 68  | 66  | 64  | 62  |
| 243  | 74                                   | 72  | 70  | 68  | 66  | 64  |
| 251  | 76                                   | 74  | 72  | 70  | 68  | 66  |
| 259  | 78                                   | 76  | 74  | 72  | 70  | 68  |
| 266  | 80                                   | 78  | 76  | 74  | 72  | 70  |
| 274  | 82                                   | 80  | 78  | 76  | 74  | 72  |
| 283  | 84                                   | 82  | 80  | 78  | 76  | 74  |
| 291  | 86                                   | 84  | 82  | 80  | 78  | 76  |
| 299  | 88                                   | 86  | 84  | 82  | 80  | 78  |
| 308  | 90                                   | 88  | 86  | 84  | 82  | 80  |
| 317  | 92                                   | 90  | 88  | 86  | 84  | 82  |
| 326  | 94                                   | 92  | 90  | 88  | 86  | 84  |
| 335  | 96                                   | 94  | 92  | 90  | 88  | 86  |
| 345  | 98                                   | 96  | 94  | 92  | 90  | 88  |
| 354  | 100                                  | 98  | 96  | 94  | 92  | 90  |
| 364  | 102                                  | 100 | 98  | 96  | 94  | 92  |
| 374  | 104                                  | 102 | 100 | 98  | 96  | 94  |
| 384  | 106                                  | 104 | 102 | 100 | 98  | 96  |
| 395  | 108                                  | 106 | 104 | 102 | 100 | 98  |
| 406  | 110                                  | 108 | 106 | 104 | 102 | 100 |
| 416  | 112                                  | 110 | 108 | 106 | 104 | 102 |
| 427  | 114                                  | 112 | 110 | 108 | 106 | 104 |
| 439  | 116                                  | 114 | 112 | 110 | 108 | 106 |
| 450  | 118                                  | 116 | 114 | 112 | 110 | 108 |
| 462  | 120                                  | 118 | 116 | 114 | 112 | 110 |
| 474  | 122                                  | 120 | 118 | 116 | 114 | 112 |
| 486  | 124                                  | 122 | 120 | 118 | 116 | 114 |
| 499  | 126                                  | 124 | 122 | 120 | 118 | 116 |
| 511  | 128                                  | 126 | 124 | 122 | 120 | 118 |

# SERVICING

To obtain the degrees temperature of superheat, subtract 50.0 from 61.0°F.

The difference is 11° Superheat. The 11° Superheat would fall in the ± range of allowable superheat.

## **SUPERHEAT AND SUBCOOLING ADJUSTMENT ON TXV APPLICATIONS**

NOTE: Units mached with indoor coils equipped with nonadjustable TXV should be charged by subcooling only.

1. Run system at least 10 minutes to allow pressure to stabilize.
2. For best results, temporarily install a thermometer on the liquid line at the liquid line service valve and 4-6" from the compressor on the suction line. Ensure the thermometer makes adequate contact and is insulated for best possible readings. Use liquid line temperature to determine sub-cooling and vapor temperature to determine superheat.

NOTE: An optional method is to locate the thermometer at the suction line service valve. Ensure the thermometer makes adequate contact and is insulated for best possible readings.

3. Check subcooling and superheat. Systems with TXV application should have a subcooling of 7 to 9 °F and superheat of 7 to 9 °F.
  - a. If subcooling and superheat are low, **adjust** TXV to 7 to 9 °F superheat, then check subcooling.

**NOTE:** To adjust superheat, turn the valve stem clockwise to increase and counter clockwise to decrease.

  - b. If subcooling is low and superheat is high, **add** charge to raise subcooling to 7 to 9 °F then check superheat.
  - c. If subcooling and superheat are high, **adjust** TXV valve to 7 to 9 °F superheat, then check subcooling.
  - d. If subcooling is high and superheat is low, **adjust** TXV valve to 7 to 9 °F superheat and **remove** charge to lower the subcooling to 7 to 9 °F.

The TXV should **NOT** be adjusted at light load conditions 55° to 60°F, under such conditions only the subcooling can be evaluated. This is because suction pressure is dependent on the indoor coil match, indoor airflow, and wet bulb temperature. **NOTE:** Do **NOT** adjust charge based on suction pressure unless there is a gross undercharge.

4. Disconnect manifold set. Installation is complete.

## **S-109 CHECKING SUBCOOLING**

Refrigerant liquid is considered subcooled when its temperature is lower than the saturation temperature corresponding to its pressure. The degree of subcooling equals the degrees of temperature decrease below the saturation temperature at the existing pressure.

1. Attach an accurate thermometer or preferably a thermocouple type temperature tester to the liquid line as it leaves the condensing unit.
2. Install a high side pressure gauge on the high side (liquid) service valve at the front of the unit.
3. Record the gauge pressure and the temperature of the line.
4. Review the technical information manual or specification sheet for the model being serviced to obtain the design subcooling.
5. Compare the hi-pressure reading to the "Required Liquid Line Temperature" chart (page 108). Find the hi-pressure value on the left column. Follow that line right to the column under the design subcooling value. Where the two intersect is the required liquid line temperature.

Alternately you can convert the liquid line pressure gauge reading to temperature by finding the gauge reading in Temperature - Pressure Chart and reading to the left, find the temperature in the °F. Column.
6. The difference between the thermometer reading and pressure to temperature conversion is the amount of subcooling.

Add charge to raise subcooling. Recover charge to lower subcooling.

**Subcooling Formula = Sat. Liquid Temp. - Liquid Line Temp.**

### **EXAMPLE:**

- a. Liquid Line Pressure = 417
- b. Corresponding Temp. °F. = 120°
- c. Thermometer on Liquid line = 109°F.

To obtain the amount of subcooling subtract 109°F from 120°F.

The difference is 11° subcooling. See the specification sheet or technical information manual for the design subcooling range for your unit.

## **S-109A TWO SPEED APPLICATION**

Run the remote on low stage cooling for 10 minutes until refrigerant pressures stabilize. Follow the guidelines and methods below to check unit operation and ensure that the refrigerant charge is within limits. Charge the unit on low stage.

1. Purge gauge lines. Connect service gauge manifold to base-valve service ports. Run system at least 10 minutes to allow pressure to stabilize.
2. For best results, temporarily install a thermometer on the liquid line at the liquid line service valve and 4-6" from the compressor on the suction line. Ensure the thermometer makes adequate contact and is insulated for best possible readings. Use liquid line temperature to determine sub-cooling and vapor temperature to determine superheat.



# SERVICING

NOTE: An optional method is to locate the thermometer at the suction line service valve. Ensure the thermometer makes adequate contact and is insulated for best possible readings.

3. Check subcooling and superheat. Systems with TXV application should have a subcooling of 7 to 9 °F and superheat of 7 to 9 °F.
  - a. If subcooling and superheat are low, **adjust** TXV to 7 to 9 °F superheat, then check subcooling.

**NOTE:** To adjust superheat, turn the valve stem clockwise to increase and counter clockwise to decrease.
  - b. If subcooling is low and superheat is high, **add** charge to raise subcooling to 7 to 9 °F then check superheat.
  - c. If subcooling and superheat are high, **adjust** TXV valve to 7 to 9 °F superheat, then check subcooling.
  - d. If subcooling is high and superheat is low, **adjust** TXV valve to 7 to 9 °F superheat and **remove** charge to lower the subcooling to 7 to 9 °F.

**NOTE:** Do **NOT** adjust the charge based on suction pressure unless there is a gross undercharge.

4. Disconnect manifold set, installation is complete.

Subcooling Formula = Sat. Liquid Temp. - Liquid Line Temp.

## S-110 CHECKING EXPANSION VALVE OPERATION

1. Remove the remote bulb of the expansion valve from the suction line.
2. Start the system and cool the bulb in a container of ice water, closing the valve. As you cool the bulb, the suction pressure should fall and the suction temperature will rise.
3. Next warm the bulb in your hand. As you warm the bulb, the suction pressure should rise and the suction temperature will fall.
4. If a temperature or pressure change is noticed, the expansion valve is operating. If no change is noticed, the valve is restricted, the power element is faulty, or the equalizer tube is plugged.
5. Capture the charge, replace the valve and drier, evacuate and recharge.

## S-111 FIXED ORIFICE RESTRICTOR DEVICES

The fixed orifice restrictor device (flowrator) used in conjunction with the indoor coil is a predetermined bore (I.D.).

It is designed to control the rate of liquid refrigerant flow into an evaporator coil.

The amount of refrigerant that flows through the fixed orifice restrictor device is regulated by the pressure difference between the high and low sides of the system.

In the cooling cycle when the outdoor air temperature rises, the high side condensing pressure rises. At the same time,

the cooling load on the indoor coil increases, causing the low side pressure to rise, but at a slower rate.

Since the high side pressure rises faster when the temperature increases, more refrigerant flows to the evaporator, increasing the cooling capacity of the system.

When the outdoor temperature falls, the reverse takes place. The condensing pressure falls, and the cooling loads on the indoor coil decreases, causing less refrigerant flow.

A strainer is placed on the entering side of the tube to prevent any foreign material from becoming lodged inside the fixed orifice restriction device.

If a restriction should become evident, proceed as follows:

1. Recover refrigerant charge.
2. Remove the orifice or tube strainer assembly and replace.
3. Replace liquid line drier, evacuate and recharge.

## CHECKING EQUALIZATION TIME

During the "OFF" cycle, the high side pressure bleeds to the low side through the fixed orifice restriction device. Check equalization time as follows:

1. Attach a gauge manifold to the suction and liquid line dill valves.
2. Start the system and allow the pressures to stabilize.
3. Stop the system and check the time it takes for the high and low pressure gauge readings to equalize.

If it takes more than seven (7) minutes to equalize, the restrictor device is inoperative. Replace, install a liquid line drier, evacuate and recharge.

## S-112 CHECKING RESTRICTED LIQUID LINE

When the system is operating, the liquid line is warm to the touch. If the liquid line is restricted, a definite temperature drop will be noticed at the point of restriction. In severe cases, frost will form at the restriction and extend down the line in the direction of the flow.

Discharge and suction pressures will be low, giving the appearance of an undercharged unit. However, the unit will have normal to high subcooling.

Locate the restriction, replace the restricted part, replace drier, evacuate and recharge.

## S-113 OVERCHARGE OF REFRIGERANT

An overcharge of refrigerant is normally indicated by an excessively high head pressure.

An evaporator coil, using an expansion valve metering device, will basically modulate and control a flooded evaporator and prevent liquid return to the compressor.

An evaporator coil, using a capillary tube metering device, could allow refrigerant to return to the compressor under extreme overcharge conditions. Also with a capillary tube metering device, extreme cases of insufficient indoor air can cause icing of the indoor coil and liquid return to the compressor, but the head pressure would be lower.

# SERVICING

## S-202 DUCT STATIC PRESSURES AND/OR STATIC PRESSURE DROP ACROSS COILS

This minimum and maximum allowable duct static pressure for the indoor sections are found in the specifications section.

Tables are also provided for each coil, listing quantity of air (CFM) versus static pressure drop across the coil.

Too great an external static pressure will result in insufficient air that can cause icing of the coil. Too much air can cause poor humidity control and condensate to be pulled off the evaporator coil causing condensate leakage. Too much air can also cause motor overloading and in many cases this constitutes a poorly designed system.

## S-203 AIR HANDLER EXTERNAL STATIC

To determine proper air movement, proceed as follows:

1. Using a draft gauge (inclined manometer), measure the static pressure of the return duct at the inlet of the unit, (Negative Pressure).
2. Measure the static pressure of the supply duct, (Positive Pressure).
3. Add the two readings together.

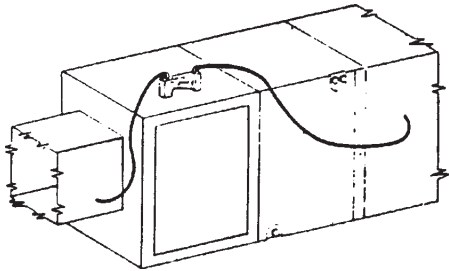

**TOTAL EXTERNAL STATIC**

**NOTE:** Both readings may be taken simultaneously and read directly on the manometer if so desired.

4. Consult proper table for quantity of air.

If external static pressure is being measured on a furnace to determine airflow, supply static must be taken between the "A" coil and the furnace.

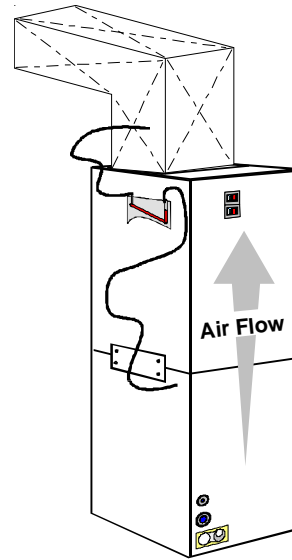

**TOTAL EXTERNAL STATIC**

## S-204 COIL STATIC PRESSURE DROP

1. Using a draft gauge (inclined manometer), connect the positive probe underneath the coil and the negative probe above the coil.
2. A direct reading can be taken of the static pressure drop across the coil.
3. Consult proper table for quantity of air.

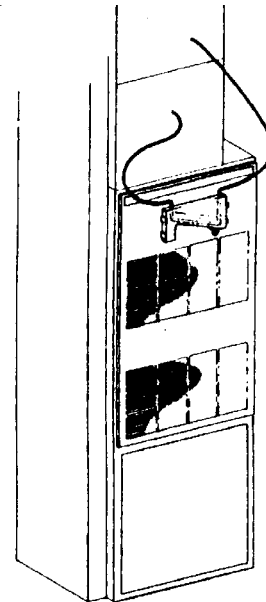

**STATIC PRESSURE DROP**

If the total external static pressure and/or static pressure drop exceeds the maximum or minimum allowable statics, check for closed dampers, dirty filters, undersized or poorly laid out duct work.

# ACCESSORIES WIRING DIAGRAMS

**WARNING**

**HIGH VOLTAGE!**  
**DISCONNECT ALL POWER BEFORE SERVICING OR INSTALLING THIS UNIT. MULTIPLE POWER SOURCES MAY BE PRESENT. FAILURE TO DO SO MAY CAUSE PROPERTY DAMAGE, PERSONAL INJURY OR DEATH.**

## ALL FUEL SYSTEM AFE18-60A CONTROL BOARD

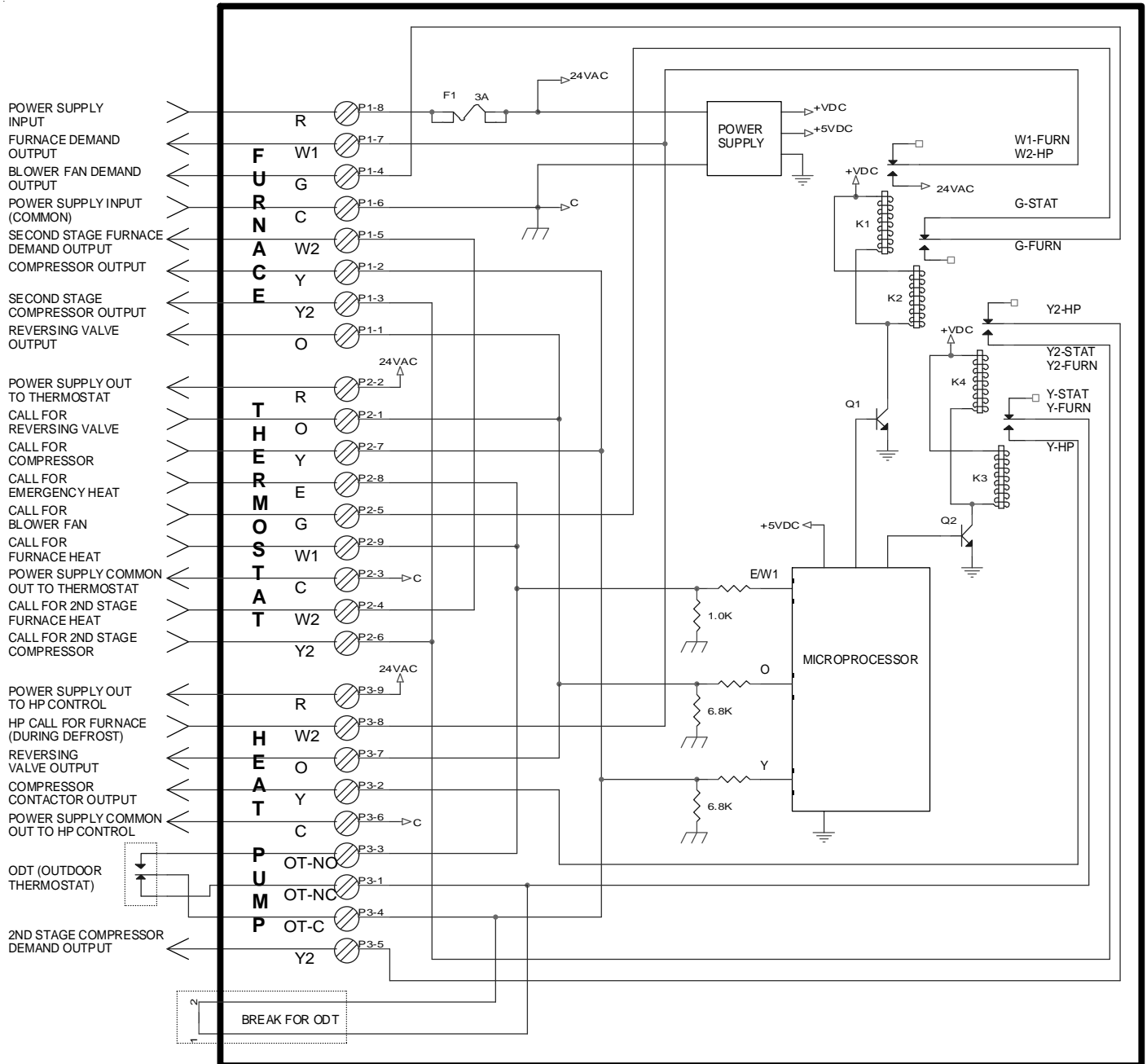

### ALL FUEL CONTROL BOARD - AFE18-60A

This wiring diagram is for reference only. Not all wiring is as shown above.

Refer to the appropriate wiring diagram for the unit being serviced.

(For use with Heat Pumps in conjunction with 80% or 90% Single-Stage or Two-Stage Furnaces)

# ACCESSORIES WIRING DIAGRAMS

**WARNING**

**HIGH VOLTAGE!**  
**DISCONNECT ALL POWER BEFORE SERVICING OR INSTALLING THIS UNIT. MULTIPLE POWER SOURCES MAY BE PRESENT. FAILURE TO DO SO MAY CAUSE PROPERTY DAMAGE, PERSONAL INJURY OR DEATH.**

## 10kw and Below, One Stage Electric Heat

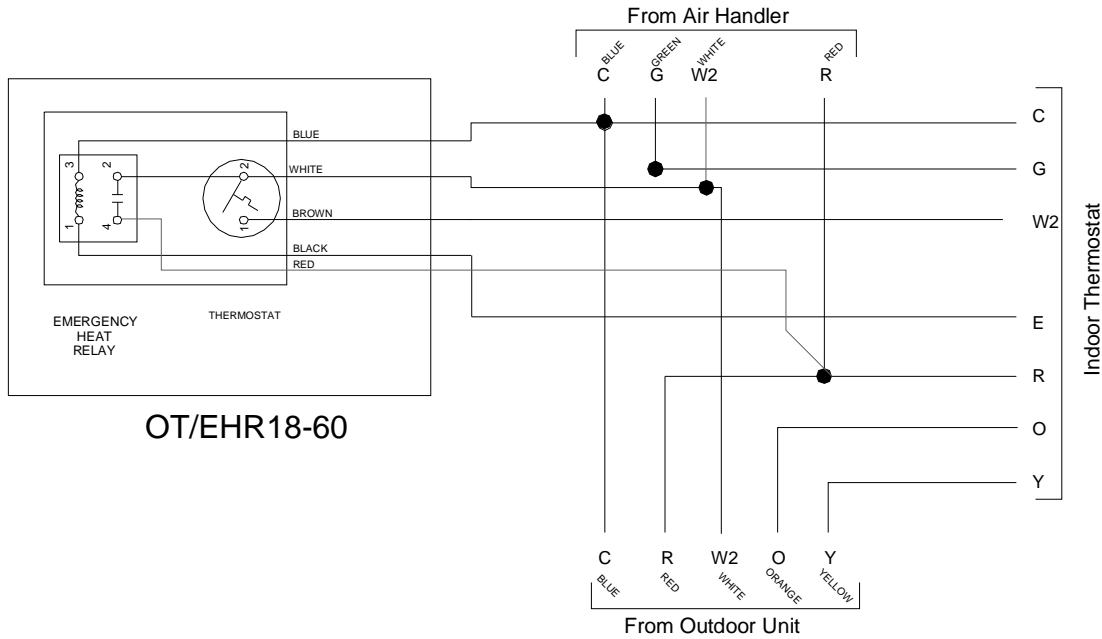

## 15kw and Above, Two Stage Electric Heat

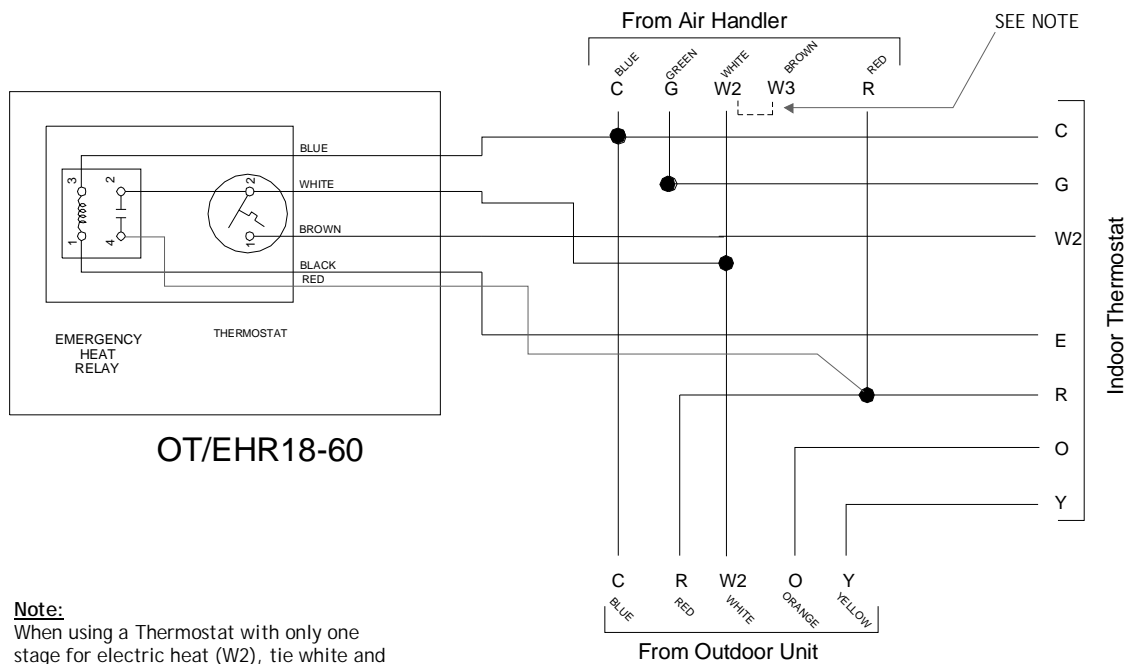

**Note:**

When using a Thermostat with only one stage for electric heat (W2), tie white and brown wires from air handler together.

Typical Wiring Schematics for OT/EHR18-60 (Outdoor Thermostat & Emergency Heat Relay).

This wiring diagram is for reference only. Not all wiring is as shown above.

Refer to the appropriate wiring diagram for the unit being serviced.

# ACCESSORIES WIRING DIAGRAMS

**WARNING**

**HIGH VOLTAGE!**  
 DISCONNECT ALL POWER BEFORE SERVICING OR INSTALLING THIS UNIT. MULTIPLE POWER SOURCES MAY BE PRESENT. FAILURE TO DO SO MAY CAUSE PROPERTY DAMAGE, PERSONAL INJURY OR DEATH.

15kw and Above with Two OT/EHR18-60's, Two Stage Electric Heat and Two Stage Thermostat

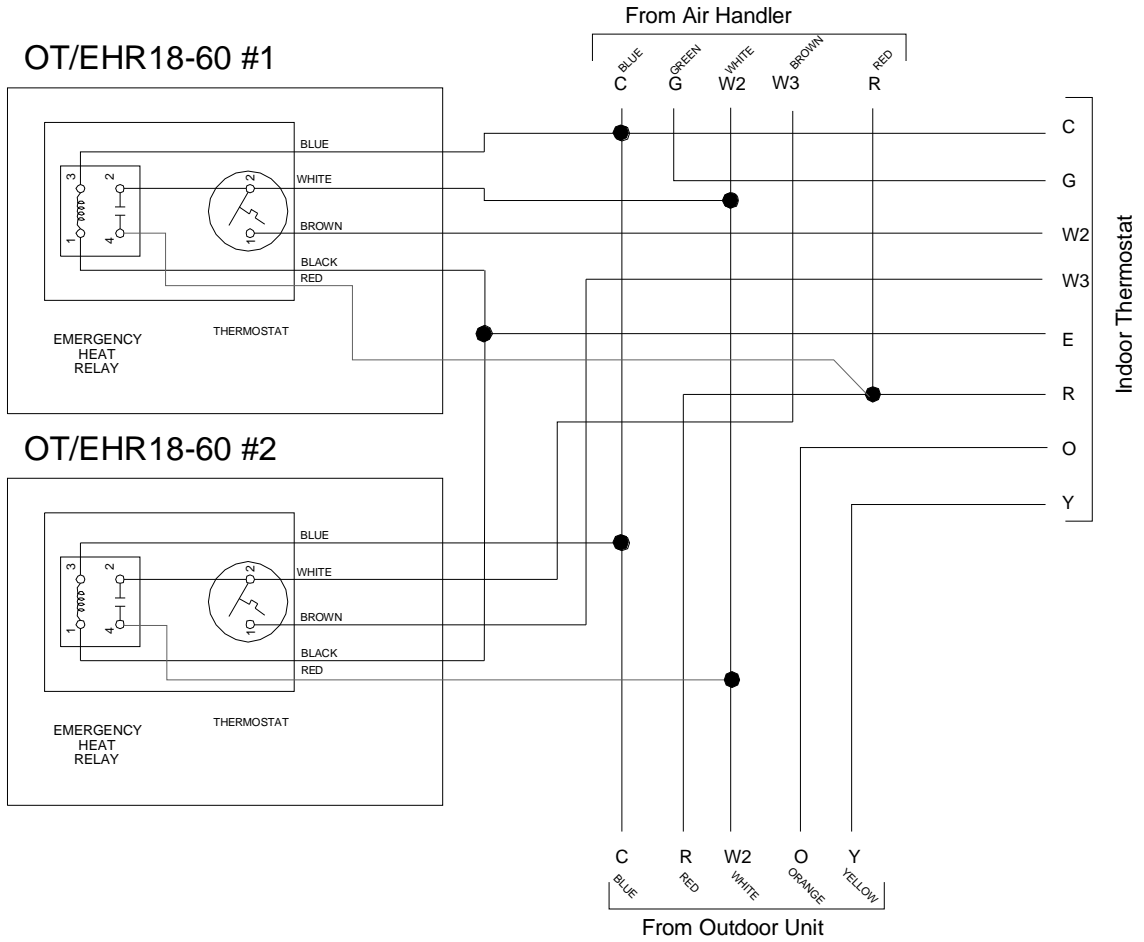

Typical Wiring Schematics for OT/EHR18-60 (Outdoor Thermostat & Emergency Heat Relay).  
 This wiring diagram is for reference only. Not all wiring is as shown above.  
 Refer to the appropriate wiring diagram for the unit being serviced.

# ACCESSORIES WIRING DIAGRAMS

# ADPF, ARPF, ARUF



**WARNING**

**HIGH VOLTAGE!**  
**DISCONNECT ALL POWER BEFORE SERVICING OR INSTALLING THIS UNIT. MULTIPLE POWER SOURCES MAY BE PRESENT. FAILURE TO DO SO MAY CAUSE PROPERTY DAMAGE, PERSONAL INJURY OR DEATH.**



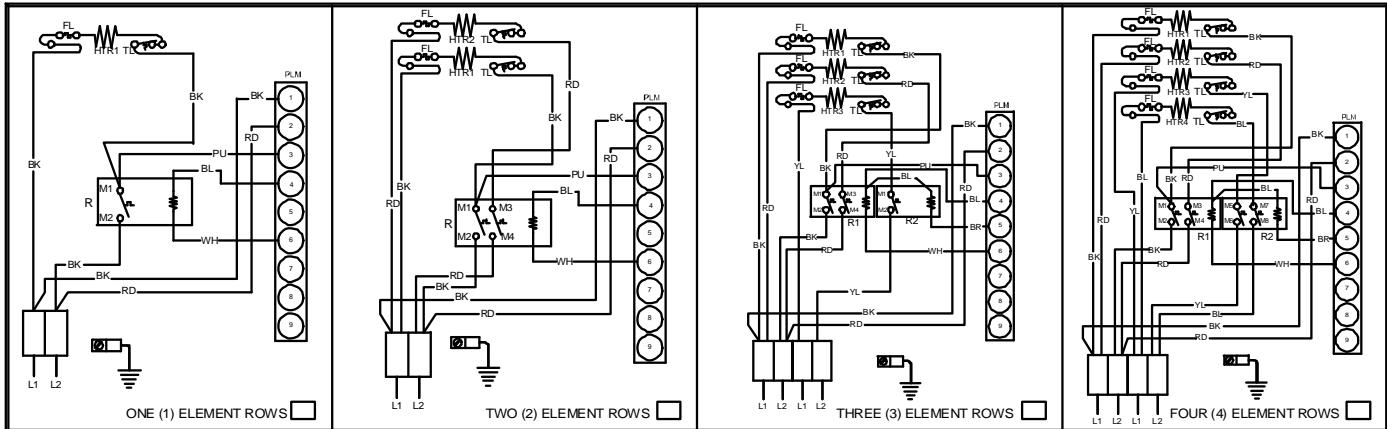

NOTE: WHEN INSTALLING HEATER KIT, ENSURE SPEED TAP DOES NOT EXCEED MINIMUM BLOWER SPEED (MBS) SPECIFIED FOR THE AIRHANDLER/HEAT ER KIT COMBINATION ON THIS UNIT'S S&R PLATE. AFTER INSTALLING OPTIONAL HEAT KIT, MARK AN "X" IN THE  PROVIDED ABOVE. MARK ACCORDING TO NUMBER OF HEATER ELEMENT ROWS INSTALLED. NO MARK INDICATES NO HEAT KIT INSTALLED.

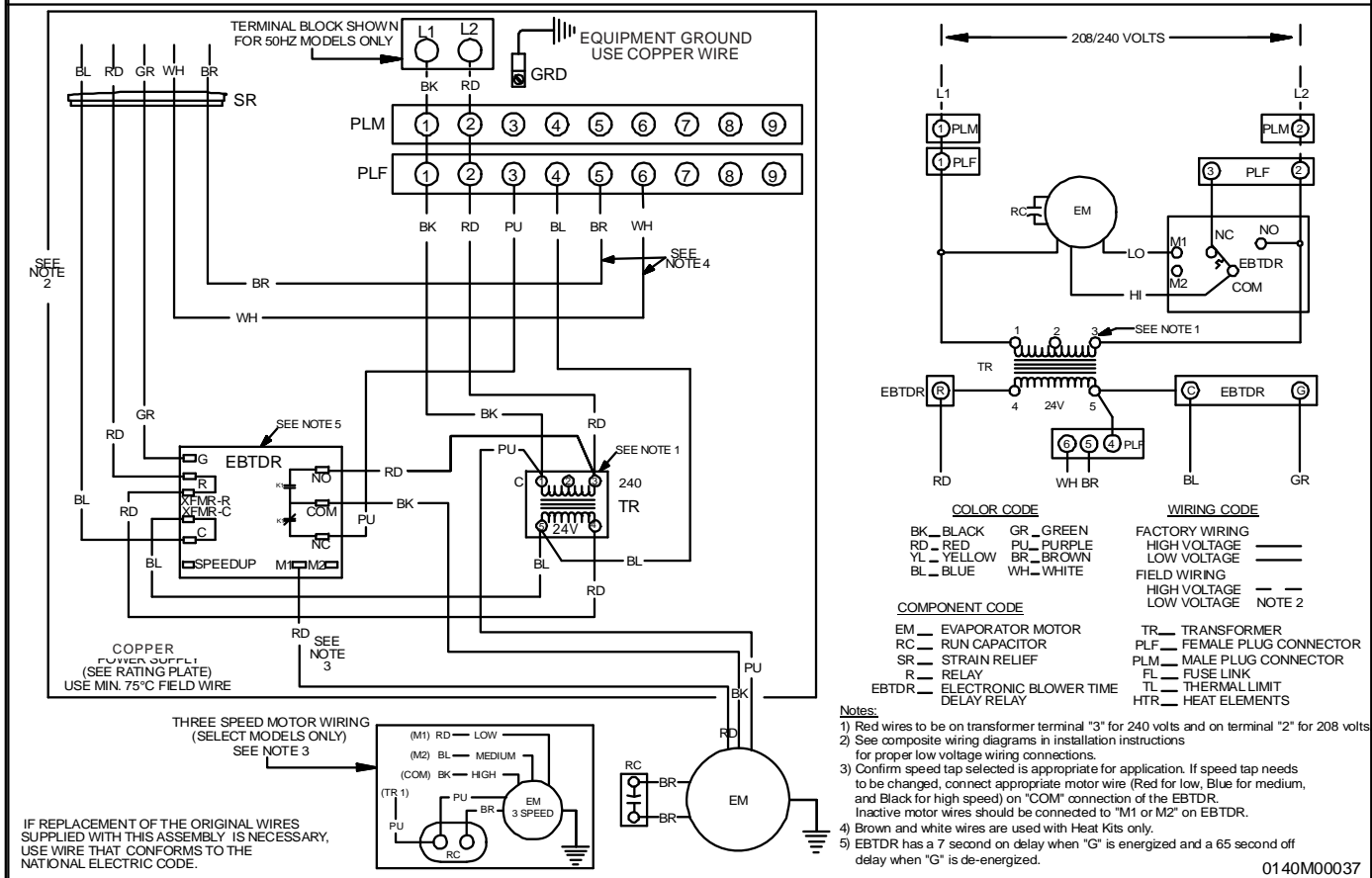

Typical Wiring Schematic ADPF, ARPF, ARUF with Electric Heat.  
 This wiring diagram is for reference only. Not all wiring is as shown above.  
 Refer to the appropriate wiring diagram for the unit being serviced.

# ACCESSORIES WIRING DIAGRAMS

MBR

**WARNING**

**HIGH VOLTAGE!**  
 DISCONNECT ALL POWER BEFORE SERVICING OR INSTALLING THIS UNIT. MULTIPLE POWER SOURCES MAY BE PRESENT. FAILURE TO DO SO MAY CAUSE PROPERTY DAMAGE, PERSONAL INJURY OR DEATH.

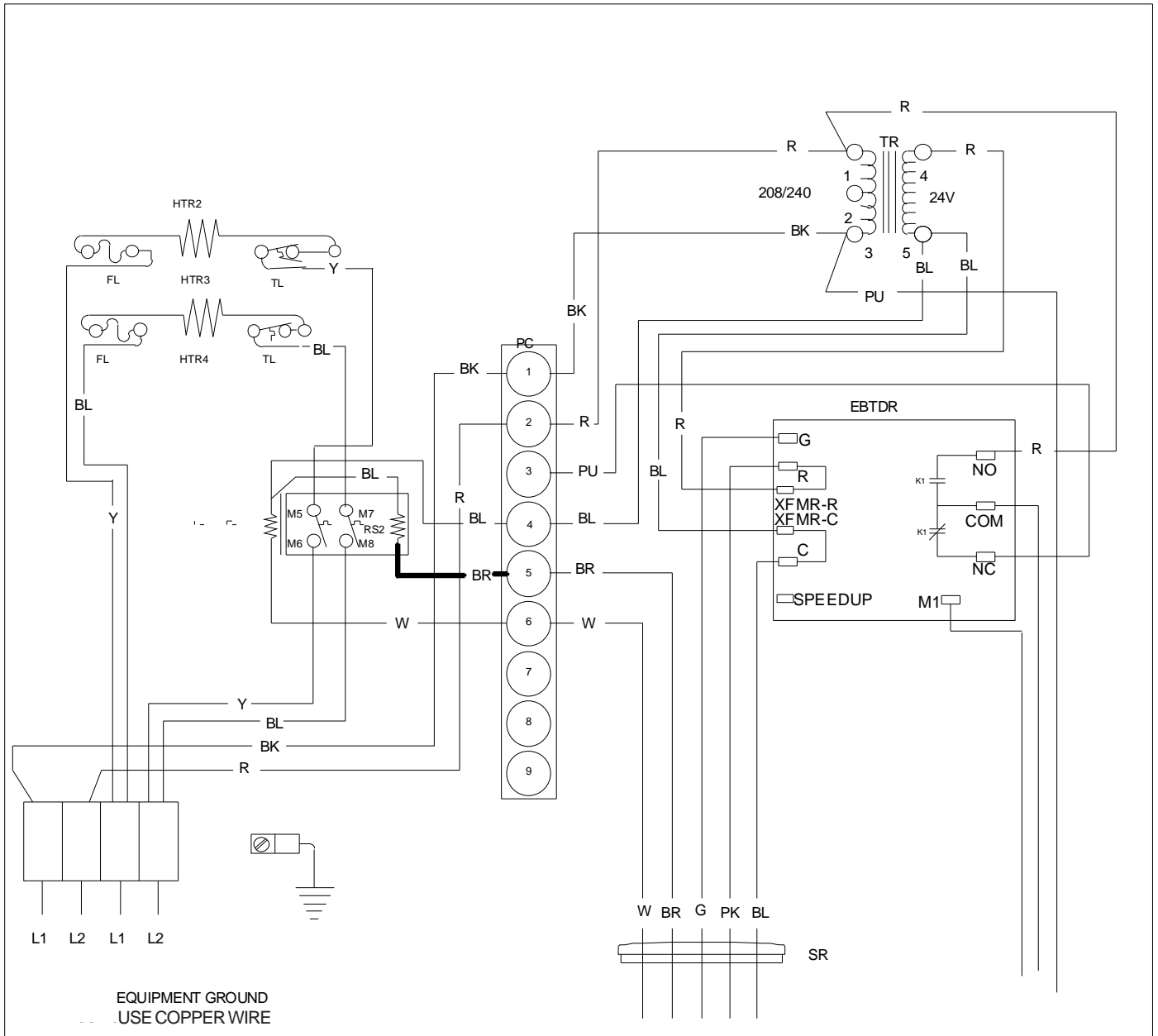

Typical Wiring Schematic MBR Blower with Electric Heat.  
 This wiring diagram is for reference only. Not all wiring is as shown above.  
 Refer to the appropriate wiring diagram for the unit being serviced.

# ACCESSORIES WIRING DIAGRAMS

AEPF



**WARNING**

**HIGH VOLTAGE!**  
**DISCONNECT ALL POWER BEFORE SERVICING OR INSTALLING THIS UNIT. MULTIPLE POWER SOURCES MAY BE PRESENT. FAILURE TO DO SO MAY CAUSE PROPERTY DAMAGE, PERSONAL INJURY OR DEATH.**



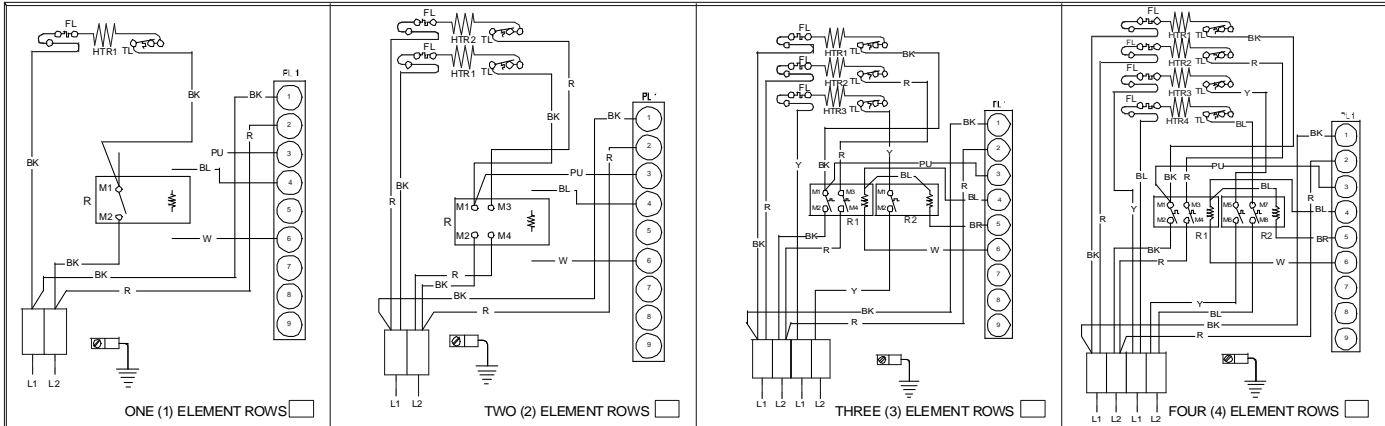

AFTER INSTALLING OPTIONAL HEAT KIT, MARK AN "X" IN THE  PROVIDED ABOVE.  
 MARK ACCORDING TO NUMBER OF HEATER ELEMENT ROWS INSTALLED  
**NO MARK INDICATES NO HEAT KIT INSTALLED**

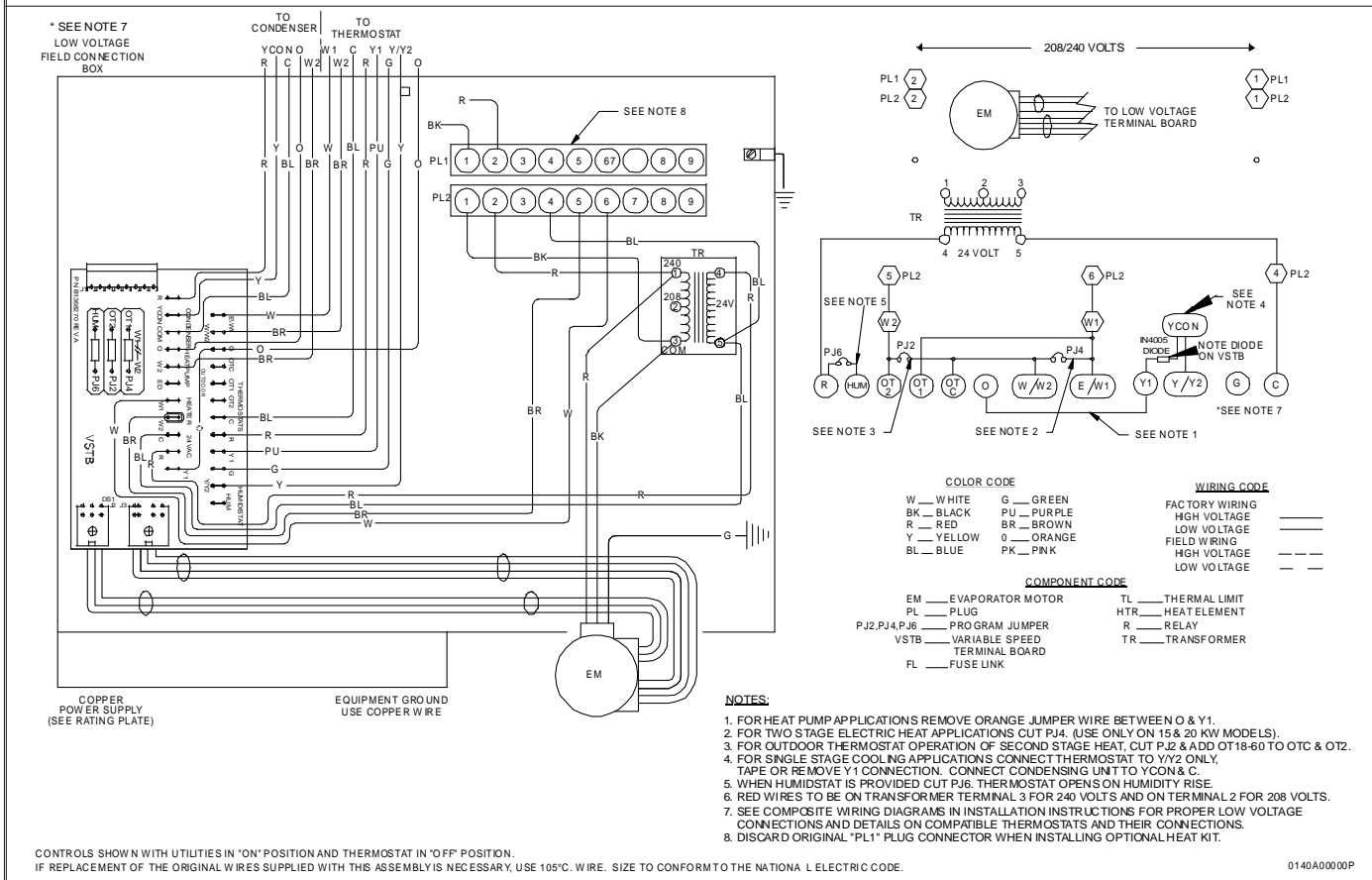

Typical Wiring Schematic AEPF with Electric Heat.  
 This wiring diagram is for reference only. Not all wiring is as shown above.  
 Refer to the appropriate wiring diagram for the unit being serviced.





# ACCESSORIES WIRING DIAGRAMS

ASPF



**WARNING**

**HIGH VOLTAGE!**  
**DISCONNECT ALL POWER BEFORE SERVICING OR INSTALLING THIS UNIT. MULTIPLE POWER SOURCES MAY BE PRESENT. FAILURE TO DO SO MAY CAUSE PROPERTY DAMAGE, PERSONAL INJURY OR DEATH.**



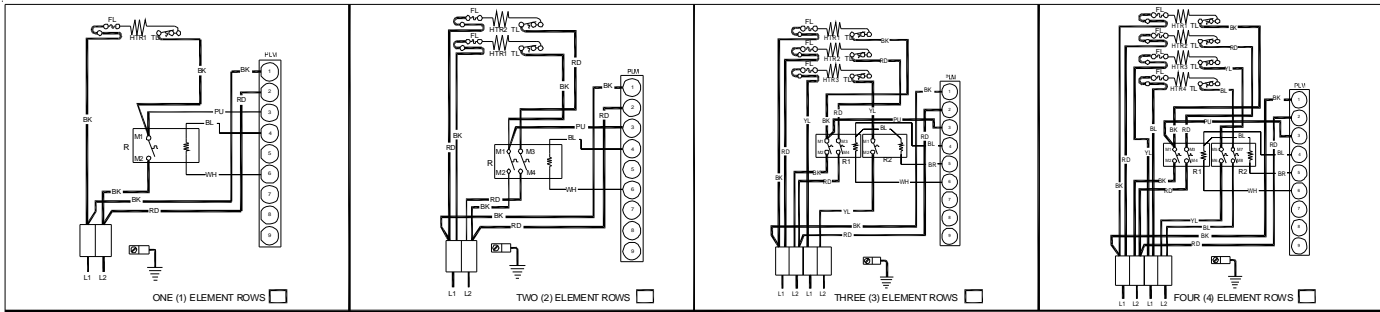

NOTE: WHEN INSTALLING HEATER KIT, ENSURE SPEED TAP DOES NOT EXCEED MINIMUM BLOWER SPEED (MBS) SPECIFIED FOR THE AIRHANDLER/HEAT ER KIT COMBINATION ON THIS UNIT'S S&R PLATE. AFTER INSTALLING OPTIONAL HEAT KIT, MARK AN "X" IN THE  PROVIDED ABOVE. MARK ACCORDING TO NUMBER OF HEATER ELEMENT ROWS INSTALLED. NO MARK INDICATES NO HEAT KIT INSTALLED.

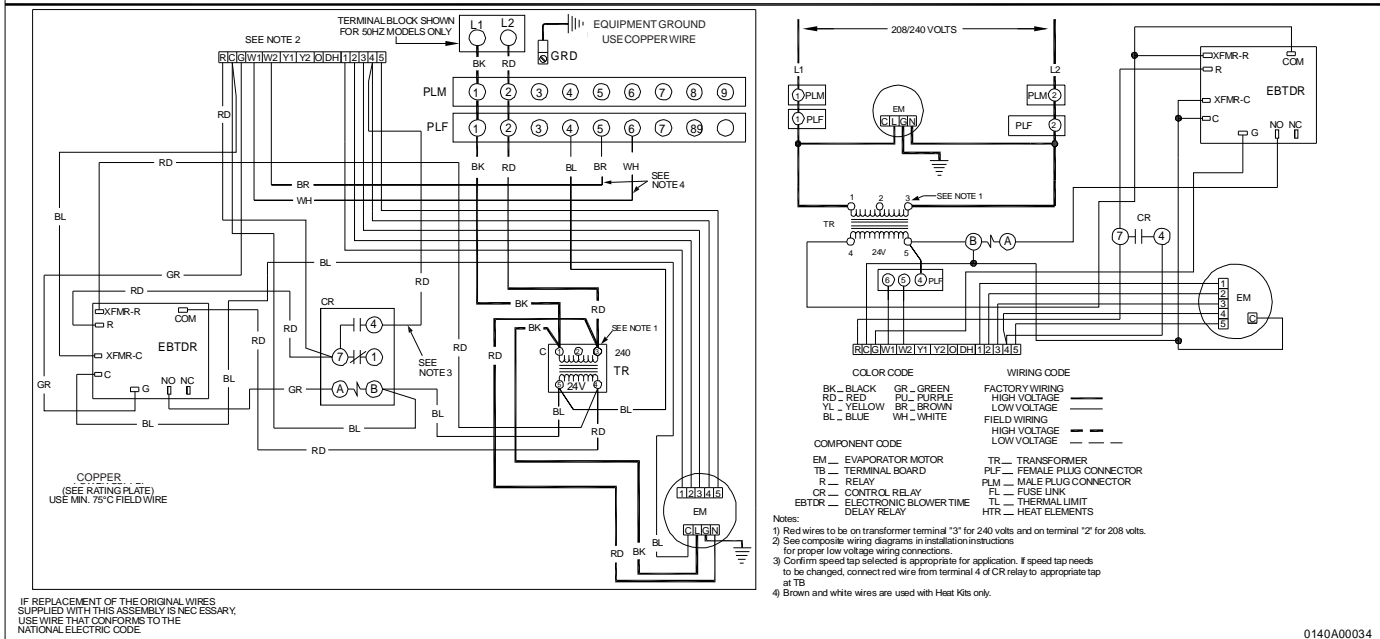

0140A00034

Typical Wiring Schematic ASPF with Electric Heat.  
 This wiring diagram is for reference only. Not all wiring is as shown above.  
 Refer to the appropriate wiring diagram for the unit being serviced.

# ACCESSORIES WIRING DIAGRAMS

ARUF\*\*14\*\* & ARPT\*\*14\*\*



**WARNING**

**HIGH VOLTAGE!**  
**DISCONNECT ALL POWER BEFORE SERVICING OR INSTALLING THIS UNIT. MULTIPLE POWER SOURCES MAY BE PRESENT. FAILURE TO DO SO MAY CAUSE PROPERTY DAMAGE, PERSONAL INJURY OR DEATH.**



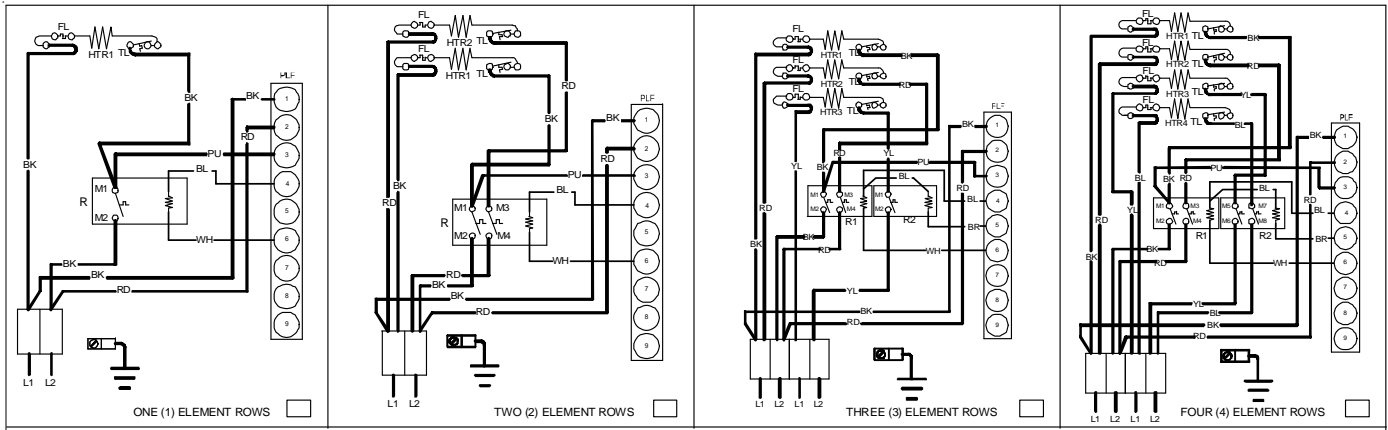

NOTE: WHEN INSTALLING HEATER KIT, ENSURE SPEED TAP IS NOT BELOW MINIMUM BLOWER SPEED (MBS) SPECIFIED FOR THE AIR HANDLER/HEATER KIT COMBINATION ON THIS UNITS SERIAL PLATE. AFTER INST ALLING OPTIONAL HEAT KIT, MARK A "X" IN THE  PROVIDED ABOVE. MARK ACCORDING TO THE NUMBER OF HEATER ELEMENT ROWS INSTALLED. NO MARK INDICATES NO HEAT KIT INSTALLED. 5 ELEMENT ROWS DATA SUPPLIED WITH HEATER KIT.

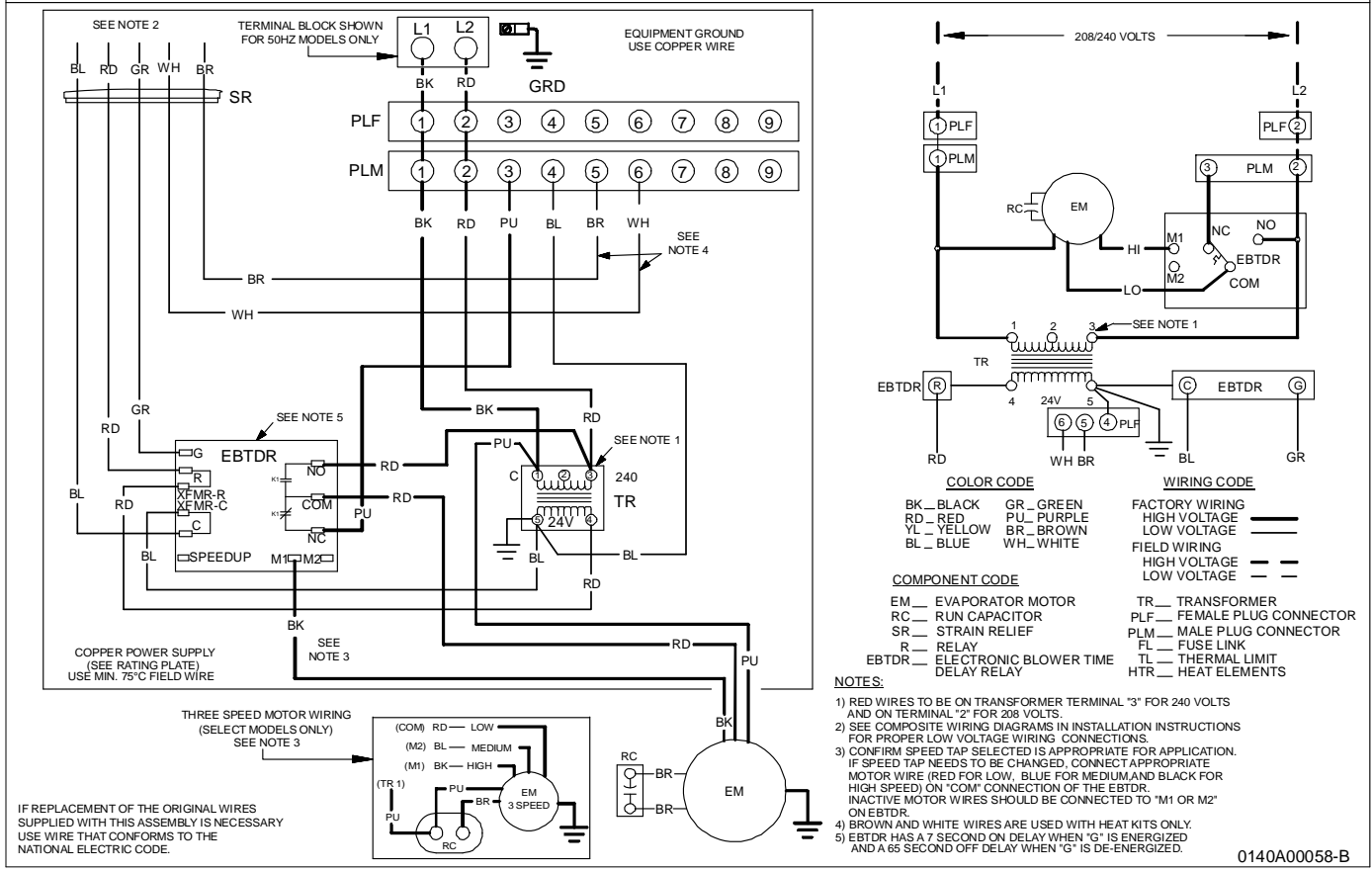

0140A00058-B

Typical Wiring Schematic ARUF\*\*14\*\* & ARPT\*\*14\*\* with Electric Heat.  
 This wiring diagram is for reference only. Not all wiring is as shown above.  
 Refer to the appropriate wiring diagram for the unit being serviced.

# ACCESSORIES WIRING DIAGRAMS

ASPT\*\*14\*\*/ASUF\*\*14\*\*

**WARNING**

**HIGH VOLTAGE!**  
**DISCONNECT ALL POWER BEFORE SERVICING OR INSTALLING THIS UNIT. MULTIPLE POWER SOURCES MAY BE PRESENT. FAILURE TO DO SO MAY CAUSE PROPERTY DAMAGE, PERSONAL INJURY OR DEATH.**

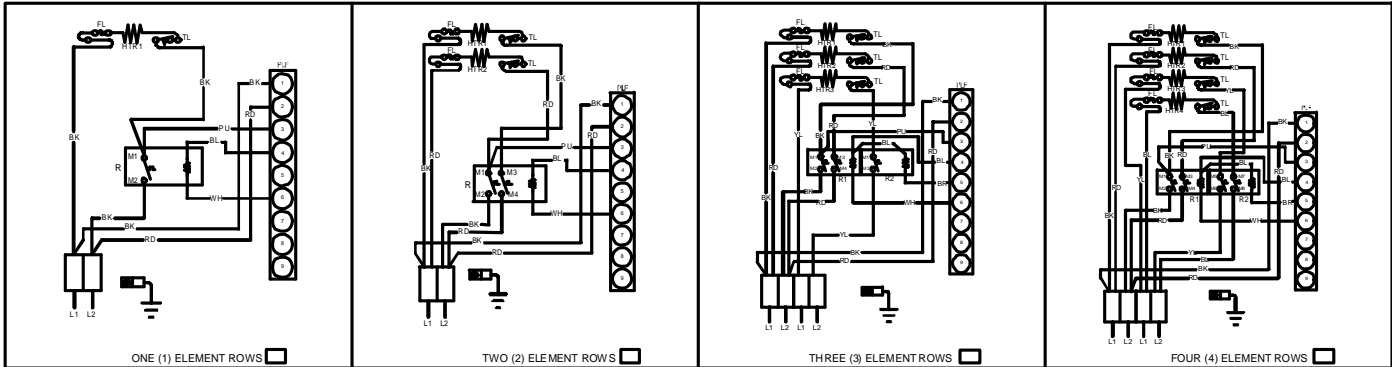

NOTE: WHEN INSTALLING HEATER KIT, ENSURE SPEED TAP DOES NOT EXCEED MINIMUM BLOWER SPEED (MBS) SPECIFIED FOR THE AIRHANDLER/HEATER KIT COMBINATION ON THIS UNIT'S S&R PLATE. AFTER INSTALLING OPTIONAL HEAT KIT, MARK A "X" IN THE BOX PROVIDED ABOVE. MARK ACCORDING TO NUMBER OF HEATER ELEMENT ROWS INSTALLED. NO MARK INDICATES NO HEAT KIT INSTALLED.

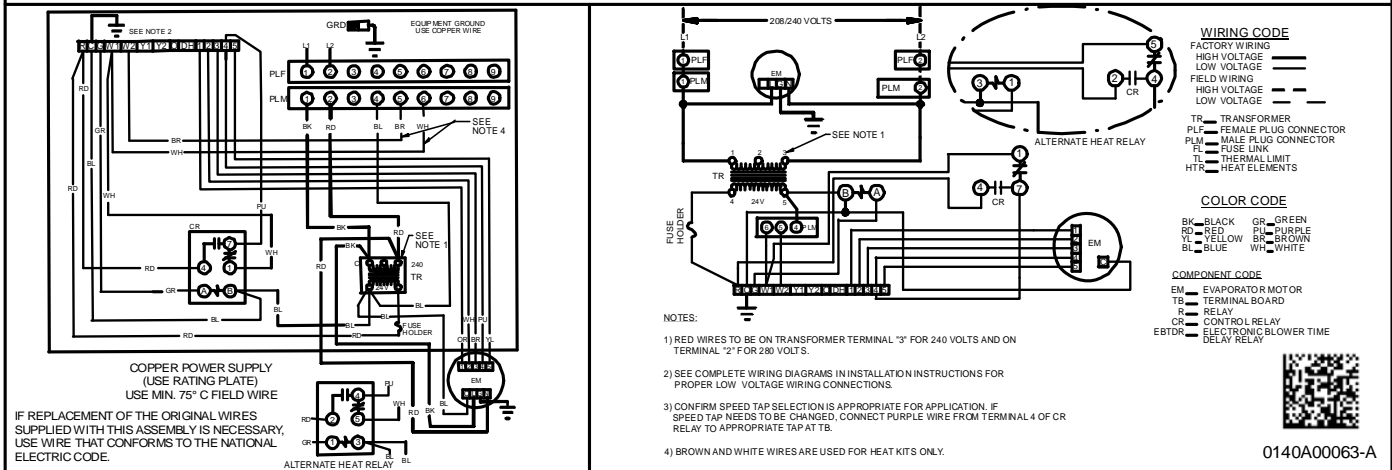

Typical Wiring Schematic ASPT\*\*14\*\* with Electric Heat.  
 This wiring diagram is for reference only. Not all wiring is as shown above.  
 Refer to the appropriate wiring diagram for the unit being serviced.

# ACCESSORIES WIRING DIAGRAMS



**WARNING**

**HIGH VOLTAGE!**  
**DISCONNECT ALL POWER BEFORE SERVICING OR INSTALLING THIS UNIT. MULTIPLE POWER SOURCES MAY BE PRESENT. FAILURE TO DO SO MAY CAUSE PROPERTY DAMAGE, PERSONAL INJURY OR DEATH.**



## 3-Phase Heat Kit

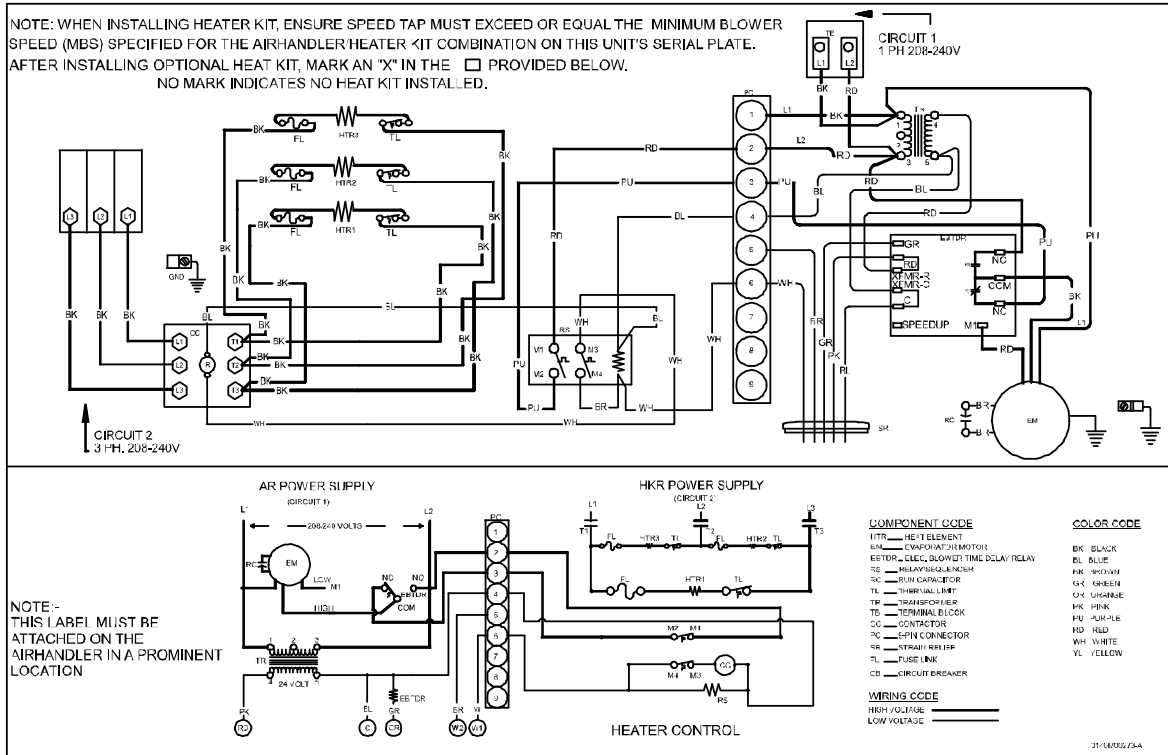

## 25kW Heat Kit

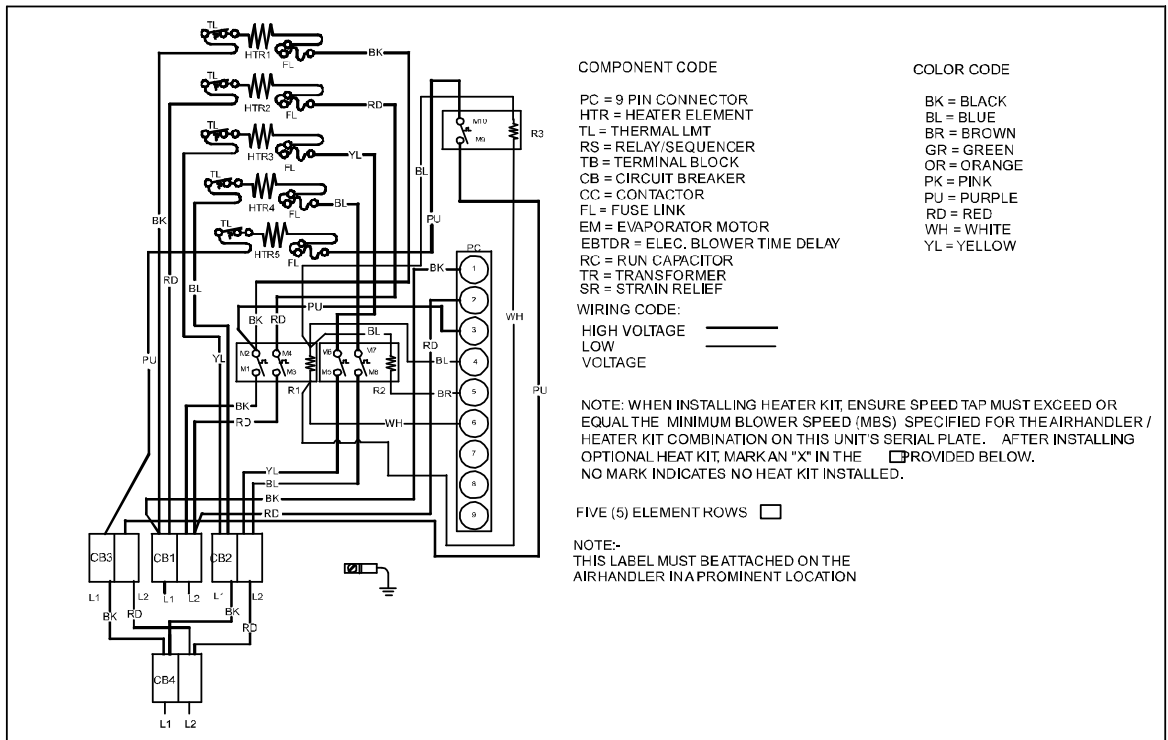

Wiring is subject to change. Always refer to the wiring diagram on the unit for the most up-to-date wiring.

**AIRHANDLERS**



**WARNING**  
 HIGH VOLTAGE!  
 DISCONNECT ALL POWER BEFORE SERVICING OR INSTALLING THIS UNIT. MULTIPLE POWER SOURCES MAY BE PRESENT. FAILURE TO DO SO MAY CAUSE PROPERTY DAMAGE, PERSONAL INJURY OR DEATH.

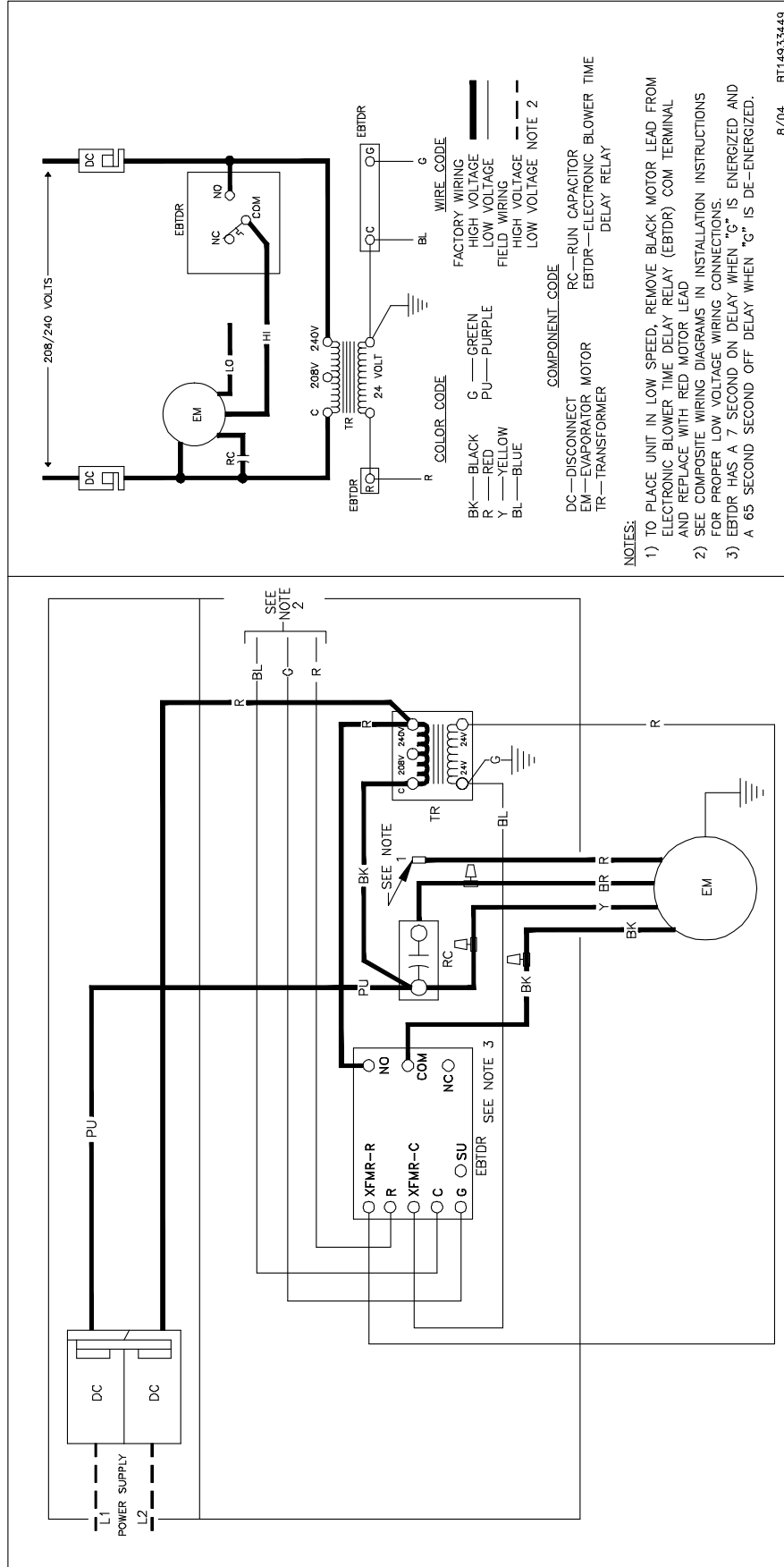

B/04 BT14933449

Wiring is subject to change. Always refer to the wiring diagram on the unit for the most up-to-date wiring.



**WARNING**  
**HIGH VOLTAGE!**  
 DISCONNECT ALL POWER BEFORE SERVICING OR INSTALLING THIS UNIT. MULTIPLE POWER SOURCES MAY BE PRESENT. FAILURE TO DO SO MAY CAUSE PROPERTY DAMAGE, PERSONAL INJURY OR DEATH.

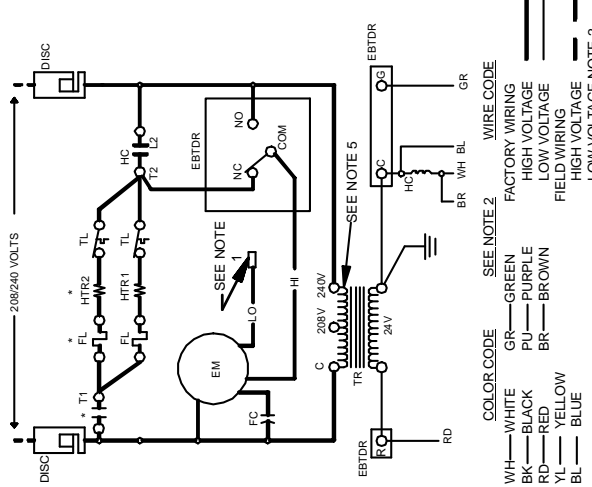
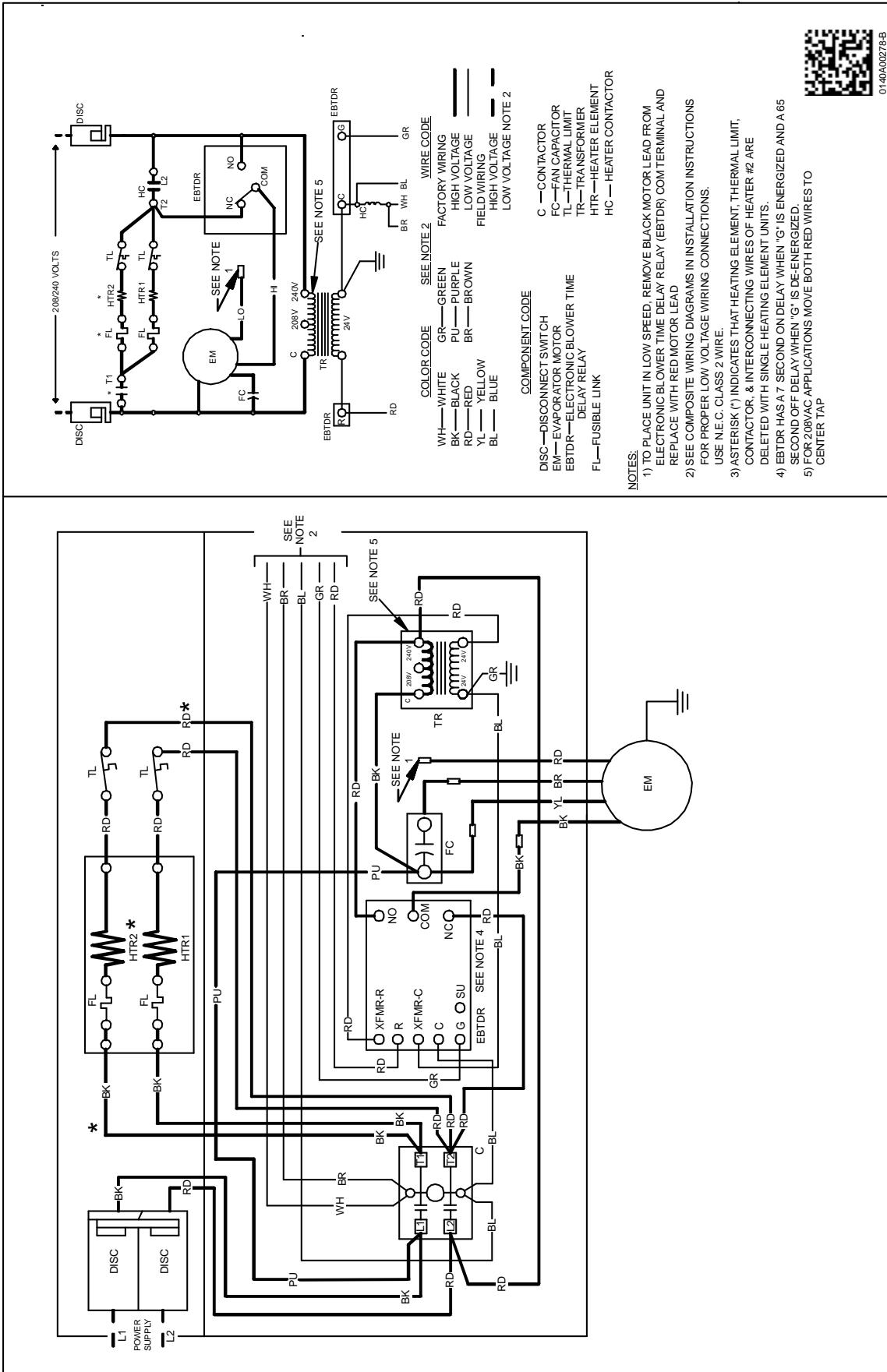

- WIRE COLOR CODE**
- WH—WHITE
  - BK—BLACK
  - RD—RED
  - YL—YELLOW
  - BL—BLUE
- WIRE CODE**
- GR—GREEN
  - PU—PURPLE
  - BR—BROWN
- FACTORY WIRING**
- HIGH VOLTAGE
  - LOW VOLTAGE
  - FIELD WIRING
  - HIGH VOLTAGE NOTE 2
  - LOW VOLTAGE NOTE 2
- COMPONENT CODE**
- C—CONTACTOR
  - FC—FAN CAPACITOR
  - EM—EVAPORATOR MOTOR
  - EBTDR—ELECTRONIC BLOWER TIME DELAY RELAY
  - FL—FUSIBLE LINK
  - HC—HEATER ELEMENT
  - HC—HEATER CONTACTOR

- NOTES:**
- 1) TO PLACE UNIT IN LOW SPEED, REMOVE BLACK MOTOR LEAD FROM ELECTRONIC BLOWER TIME DELAY RELAY (EBTDR) COM TERMINAL AND REPLACE WITH RED MOTOR LEAD
  - 2) SEE COMPOSITE WIRING DIAGRAMS IN INSTALLATION INSTRUCTIONS FOR PROPER LOW VOLTAGE WIRING CONNECTIONS. USE N.E.C. CLASS 2 WIRE.
  - 3) ASTERISK (\*) INDICATES THAT HEATING ELEMENT, THERMAL LIMIT, CONTACTOR, & INTERCONNECTING WIRES OF HEATER #2 ARE DELETED WITH SINGLE HEATING ELEMENT UNITS.
  - 4) EBTDR HAS A 7 SECOND ON DELAY WHEN "G" IS ENERGIZED AND A 65 SECOND OFF DELAY WHEN "G" IS DE-ENERGIZED.
  - 5) FOR 208VAC APPLICATIONS MOVE BOTH RED WIRES TO CENTER TAP



01-60A00275-B

Wiring is subject to change. Always refer to the wiring diagram on the unit for the most up-to-date wiring.



# WIRING DIAGRAMS

# ADPF, ARPF, ARUF, ATUF

**HIGH VOLTAGE!**  
**DISCONNECT ALL POWER BEFORE SERVICING OR INSTALLING THIS UNIT. MULTIPLE POWER SOURCES MAY BE PRESENT. FAILURE TO DO SO MAY CAUSE PROPERTY DAMAGE, PERSONAL INJURY OR DEATH.**  
**WARNING**

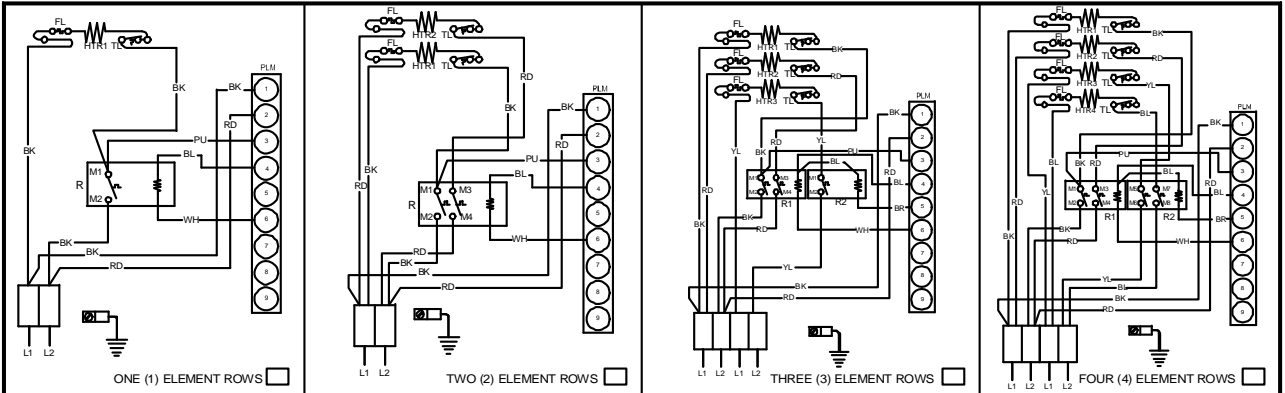

NOTE: WHEN INSTALLING HEATER KIT, ENSURE SPEED TAP DOES NOT EXCEED MINIMUM BLOWER SPEED (MBS) SPECIFIED FOR THE AIRHANDLER/HEAT ER KIT COMBINATION ON THIS UNIT'S S&R PLATE. AFTER INSTALLING OPTIONAL HEAT KIT, MARK AN "X" IN THE  PROVIDED ABOVE. MARK ACCORDING TO NUMBER OF HEATER ELEMENT ROWS INSTALLED. NO MARK INDICATES NO HEAT KIT INSTALLED.

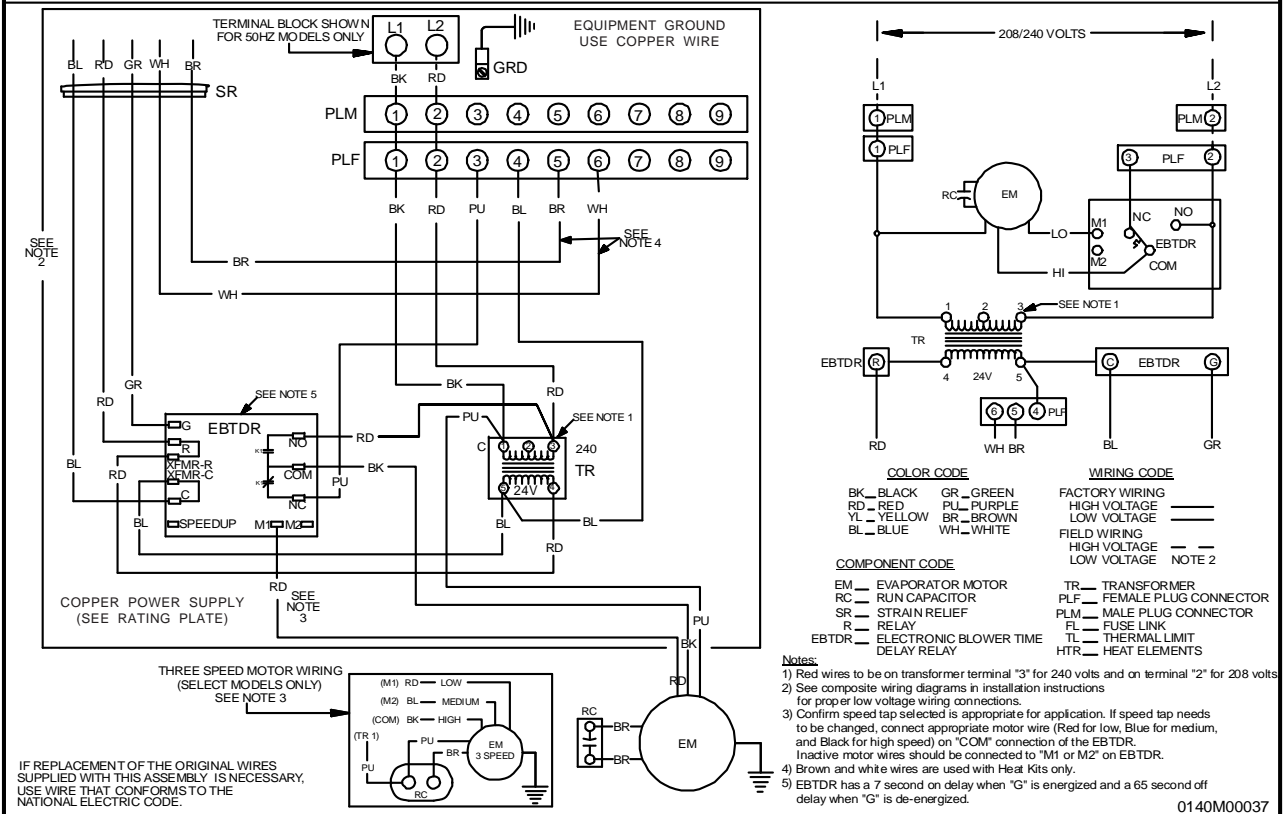

|                   |             |                    |       |
|-------------------|-------------|--------------------|-------|
| <b>COLOR CODE</b> |             | <b>WIRING CODE</b> |       |
| BK _ BLACK        | GR _ GREEN  | FACTORY WIRING     | ===== |
| RD _ RED          | PU _ PURPLE | HIGH VOLTAGE       | ===== |
| YL _ YELLOW       | BR _ BROWN  | LOW VOLTAGE        | ===== |
| BL _ BLUE         | WH _ WHITE  | FIELD WIRING       | ----- |
|                   |             | HIGH VOLTAGE       | ----- |
|                   |             | LOW VOLTAGE        | ----- |

- COMPONENT CODE**
- |  |                             |
|--|-----------------------------|
| EM _ EVAPORATOR MOTOR                      | TR _ TRANSFORMER            |
| RC _ RUN CAPACITOR                         | PLF _ FEMALE PLUG CONNECTOR |
| SR _ STRAIN RELIEF                         | PLM _ MALE PLUG CONNECTOR   |
| R _ RELAY                                  | FL _ FUSE LINK              |
| EBTDR _ ELECTRONIC BLOWER TIME DELAY RELAY | TL _ THERMAL LIMIT          |
|  | HTR _ HEAT ELEMENTS         |
- Notes:**
- 1) Red wires to be on transformer terminal "3" for 240 volts and on terminal "2" for 208 volts
  - 2) See composite wiring diagrams in installation instructions for proper low voltage wiring connections.
  - 3) Confirm speed tap selected is appropriate for application. If speed tap needs to be changed, connect appropriate motor wire (Red for low, Blue for medium, and Black for high speed) on "COM" connection of the EBTDR. Inactive motor wires should be connected to "M1" or "M2" on EBTDR.
  - 4) Brown and white wires are used with Heat Kits only.
  - 5) EBTDR has a 7 second on delay when "G" is energized and a 65 second off delay when "G" is de-energized.

0140M00037

Wiring is subject to change. Always refer to the wiring diagram on the unit for the most up-to-date wiring.

# WIRING DIAGRAMS

# ADPF, ARPF, ARUF, ATUF



**HIGH VOLTAGE!**  
 DISCONNECT ALL POWER BEFORE SERVICING OR INSTALLING THIS UNIT. MULTIPLE POWER SOURCES MAY BE PRESENT. FAILURE TO DO SO MAY CAUSE PROPERTY DAMAGE, PERSONAL INJURY OR DEATH.

**WARNING**

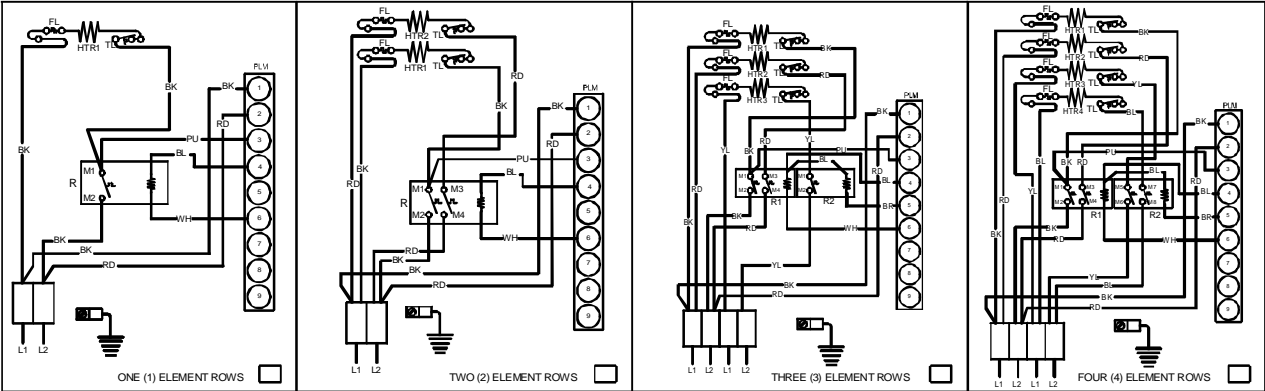

NOTE: WHEN INSTALLING HEATER KIT, ENSURE SPEED TAP DOES NOT EXCEED MINIMUM BLOWER SPEED (MBS) SPECIFIED FOR THE AIRHANDLER/HEATER KIT COMBINATION ON THIS UNIT'S S&R PLATE. AFTER INSTALLING OPTIONAL HEAT KIT, MARKA "X" IN THE  PROVIDED ABOVE. MARK ACCORDING TO NUMBER OF HEATER ELEMENT ROWS INSTALLED. NO MARK INDICATES NO HEAT KIT INSTALLED.

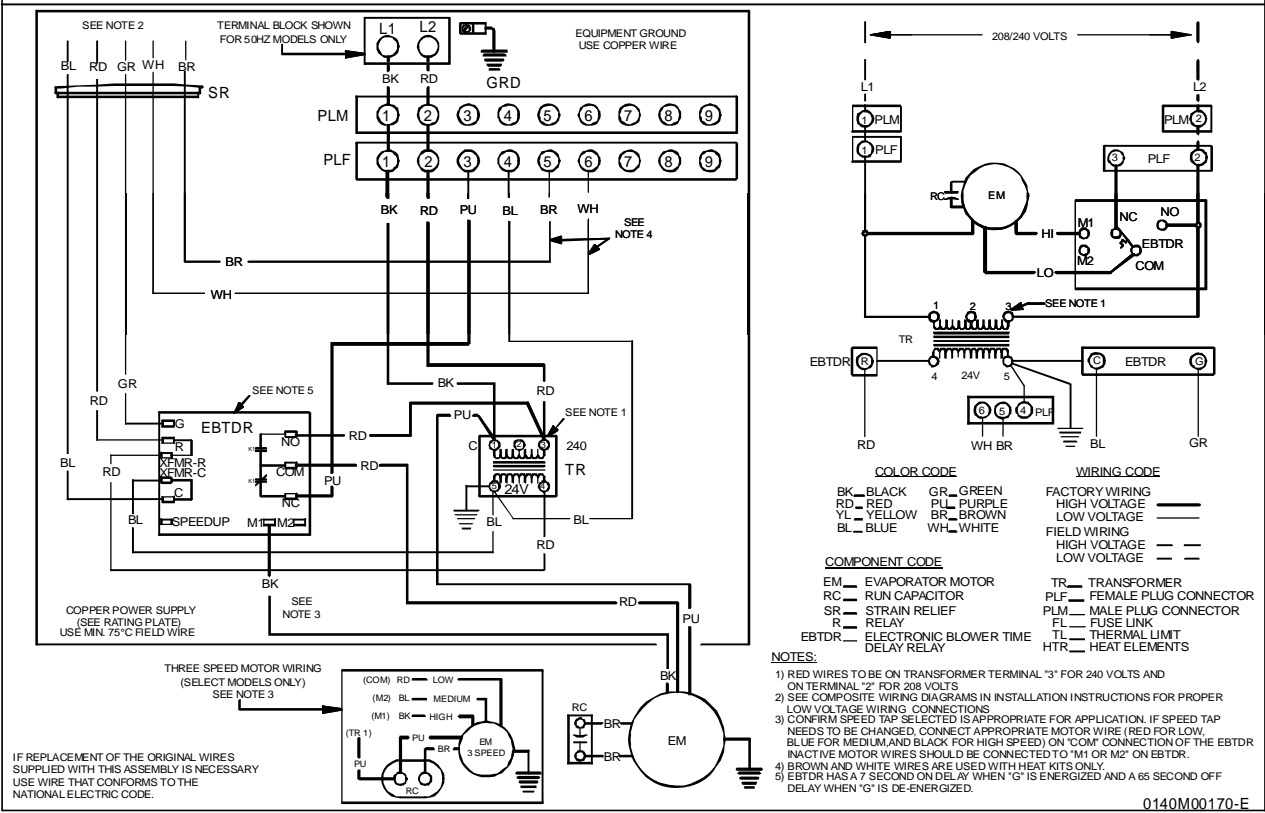

| COLOR CODE     |                                    | WIRING CODE    |                       |
|----------------|------------------------------------|----------------|-----------------------|
| BK             | BLACK                              | GR             | GREEN                 |
| RD             | RED                                | PL             | PURPLE                |
| YL             | YELLOW                             | BR             | BROWN                 |
| BL             | BLUE                               | WH             | WHITE                 |
| COMPONENT CODE |                                    | FACTORY WIRING |                       |
| EM             | EVAPORATOR MOTOR                   | TR             | TRANSFORMER           |
| RC             | RUN CAPACITOR                      | PLF            | FEMALE PLUG CONNECTOR |
| R              | RELAY                              | SR             | STRAIN RELIEF         |
| EBTDR          | ELECTRONIC BLOWER TIME DELAY RELAY | FL             | FUSE LINK             |
|                |                                    | TL             | THERMAL LIMIT         |
|                |                                    | HTR            | HEAT ELEMENTS         |

- NOTES:
- 1) RED WIRES TO BE ON TRANSFORMER TERMINAL "3" FOR 240 VOLTS AND ON TERMINAL "2" FOR 208 VOLTS
  - 2) SEE COMPOSITE WIRING DIAGRAMS IN INSTALLATION INSTRUCTIONS FOR PROPER LOW VOLTAGE WIRING CONNECTIONS
  - 3) CONFIRM SPEED TAP SELECTED IS APPROPRIATE FOR APPLICATION. IF SPEED TAP NEEDS TO BE CHANGED, CONNECT APPROPRIATE MOTOR WIRE (RED FOR LOW, BLUE FOR MEDIUM AND BLACK FOR HIGH SPEED) ON "COM" CONNECTION OF THE EBTDR. INACTIVE MOTOR WIRES SHOULD BE CONNECTED TO "M1 OR M2" ON EBTDR.
  - 4) BROWN AND WHITE WIRES ARE USED WITH HEAT KITS ONLY.
  - 5) EBTDR HAS A 7 SECOND ON DELAY WHEN "G" IS ENERGIZED AND A 65 SECOND OFF DELAY WHEN "G" IS DE-ENERGIZED.

0140M00170-E

Wiring is subject to change. Always refer to the wiring diagram on the unit for the most up-to-date wiring.

# WIRING DIAGRAMS

# ADPF, ARPF, ARUF, ATUF

EFFECTIVE 12/24/14

**HIGH VOLTAGE!**  
**DISCONNECT ALL POWER BEFORE SERVICING OR INSTALLING THIS UNIT. MULTIPLE POWER SOURCES MAY BE PRESENT. FAILURE TO DO SO MAY CAUSE PROPERTY DAMAGE, PERSONAL INJURY OR DEATH.**  
**WARNING**

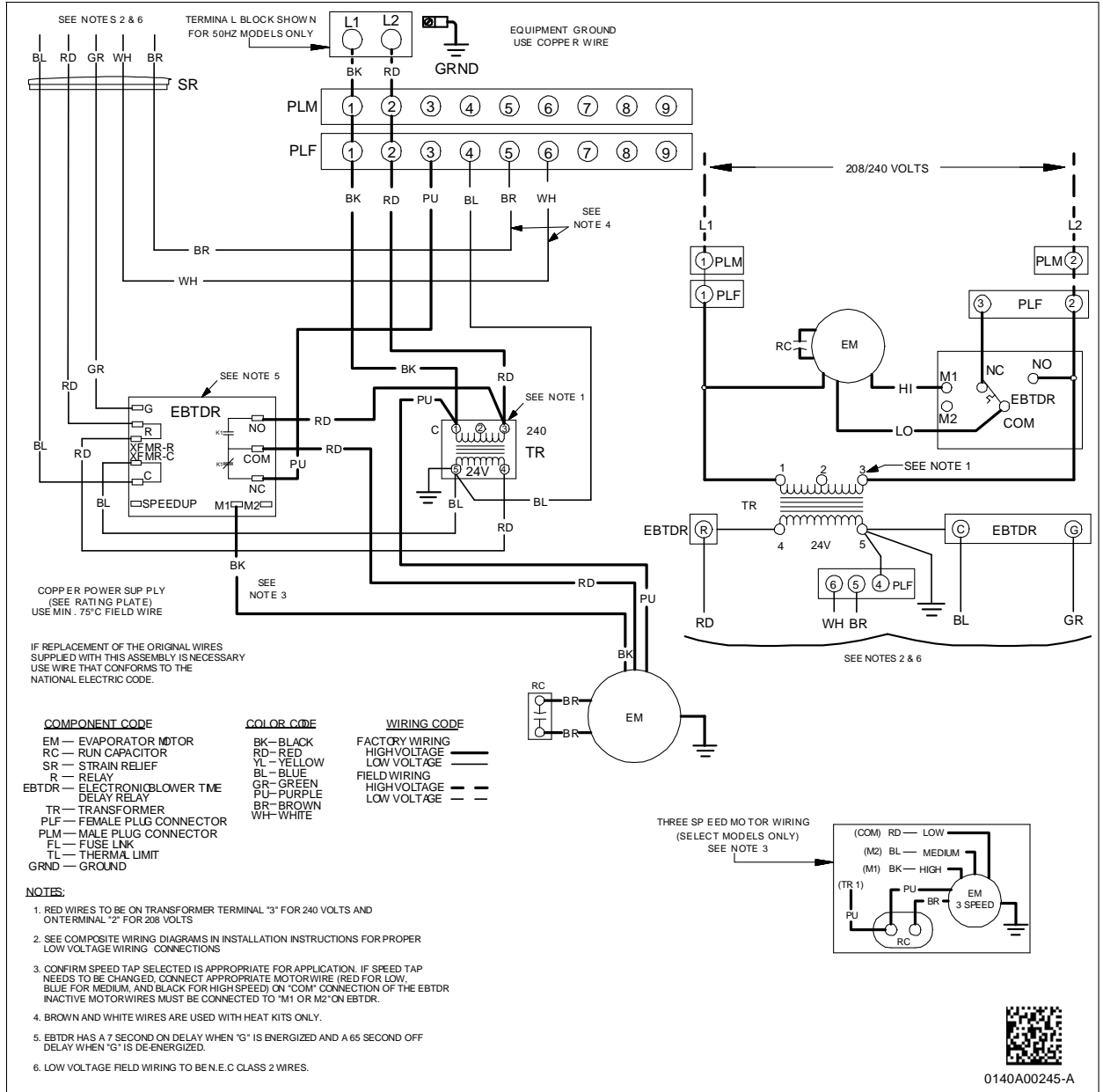

Wiring is subject to change. Always refer to the wiring diagram on the unit for the most up-to-date wiring.



**HIGH VOLTAGE!**  
 DISCONNECT ALL POWER BEFORE SERVICING OR INSTALLING THIS UNIT. MULTIPLE POWER SOURCES MAY BE PRESENT. FAILURE TO DO SO MAY CAUSE PROPERTY DAMAGE, PERSONAL INJURY OR DEATH.

**WARNING**

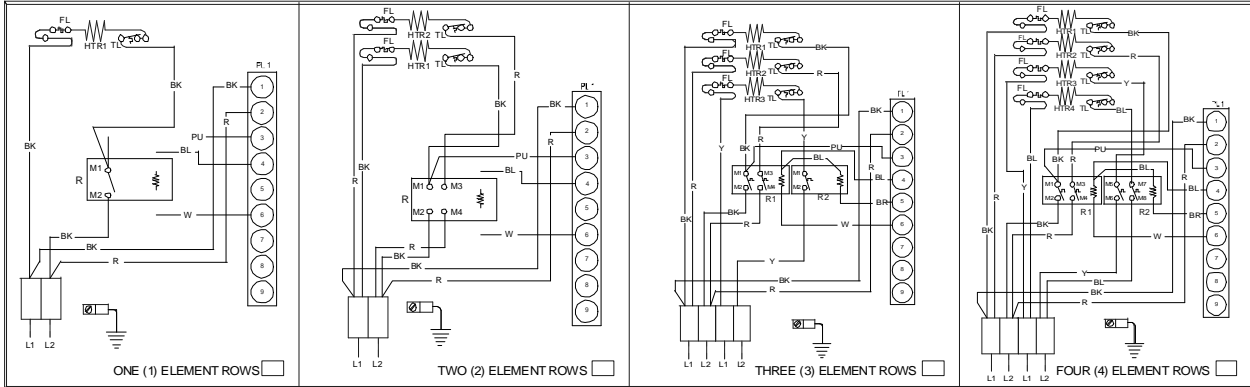

AFTER INSTALLING OPTIONAL HEAT KIT, MARK AN "X" IN THE  PROVIDED ABOVE.  
 MARK ACCORDING TO NUMBER OF HEATER ELEMENT ROWS INSTALLED  
**NO MARK INDICATES NO HEAT KIT INSTALLED**

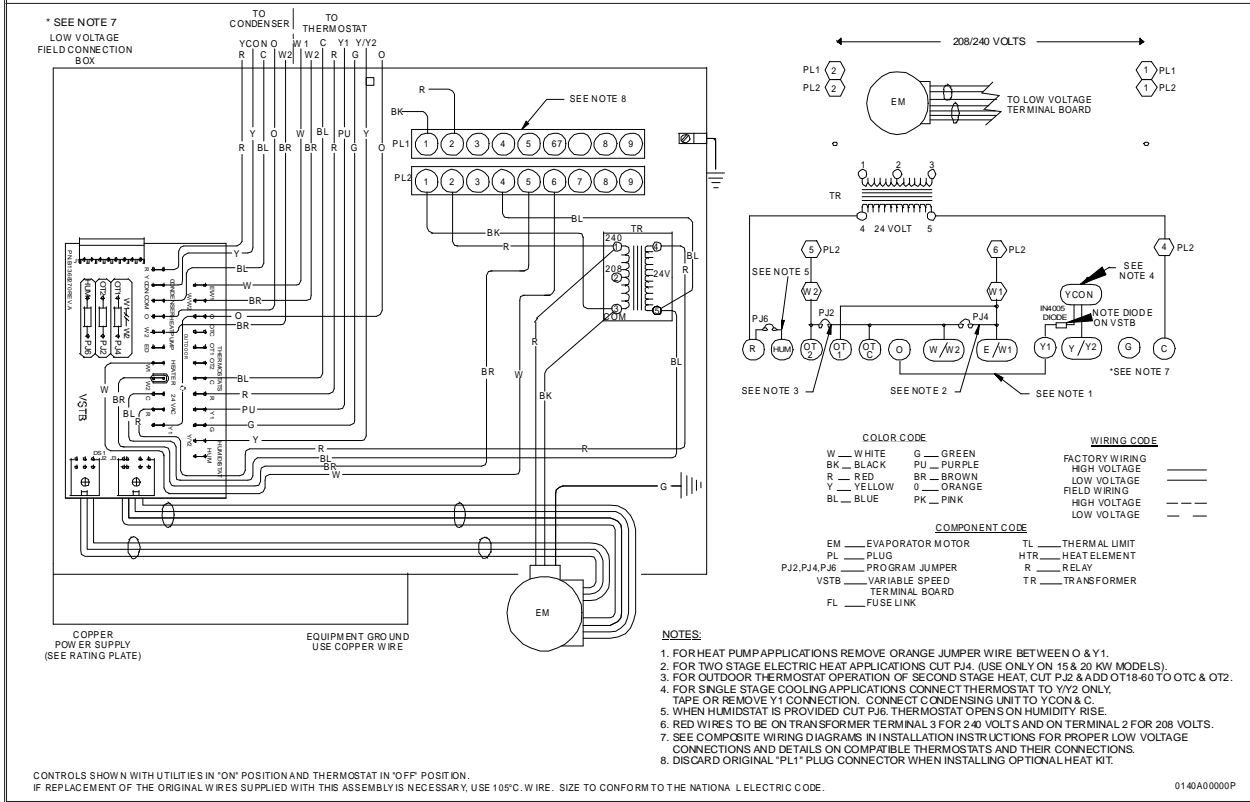

# WIRING DIAGRAMS

AEPF\*\*\*\*\*CA



**HIGH VOLTAGE!**  
 DISCONNECT ALL POWER BEFORE SERVICING OR INSTALLING THIS UNIT. MULTIPLE POWER SOURCES MAY BE PRESENT. FAILURE TO DO SO MAY CAUSE PROPERTY DAMAGE, PERSONAL INJURY OR DEATH.

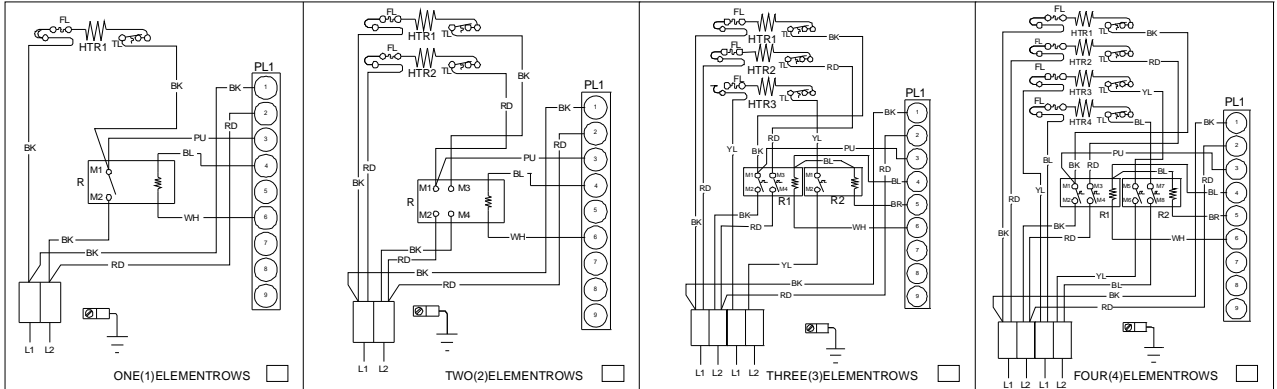

AFTER INSTALLING OPTIONAL HEAT KIT, MARK "X" IN THE PROVIDED ABOVE. MARK ACCORDING TO NUMBER OF HEATER ELEMENT ROWS INSTALLED. NO MARK INDICATES NO HEAT KIT INSTALLED.

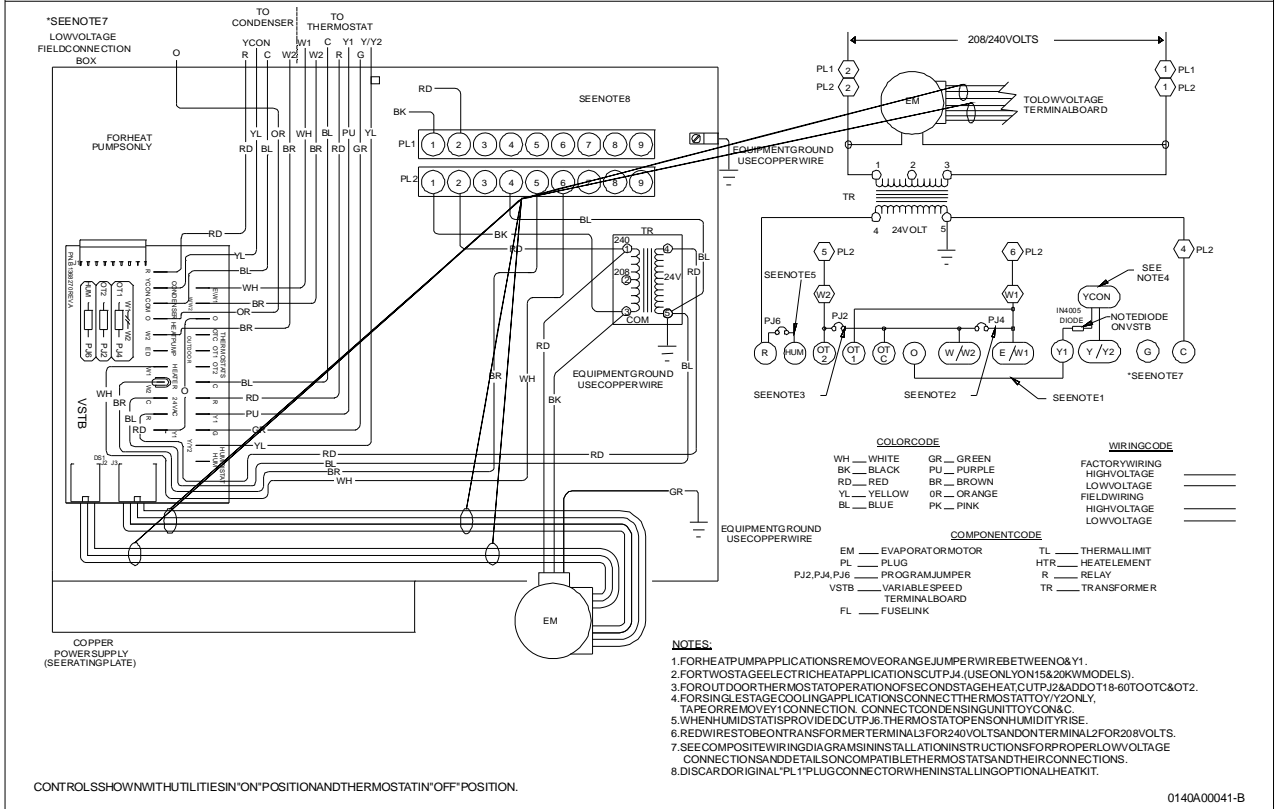

0140A00041-B



**HIGH VOLTAGE!**  
 DISCONNECT ALL POWER BEFORE SERVICING OR INSTALLING THIS UNIT. MULTIPLE POWER SOURCES MAY BE PRESENT. FAILURE TO DO SO MAY CAUSE PROPERTY DAMAGE, PERSONAL INJURY OR DEATH.

**WARNING**

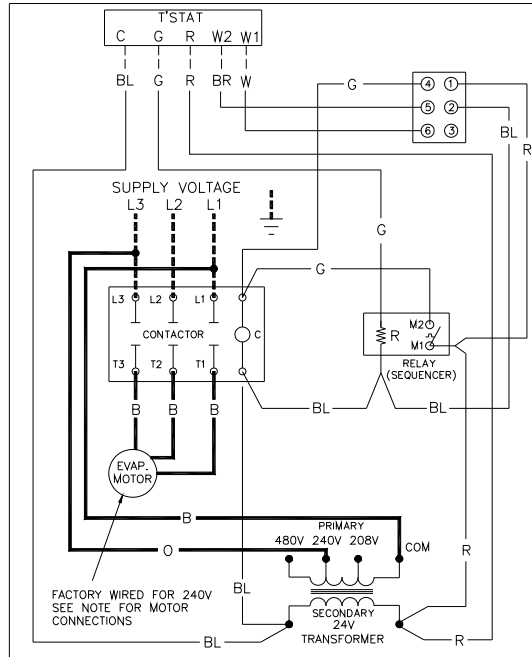

- NOTES**
- ALL REPLACEMENT WIRES MUST BE SAME GAUGE AND TYPE.
  - TO CHANGE VOLTAGE FROM 240V TO 208V, MOVE WIRE FROM 240V TAP TO 208V TAP AT TRANSFORMER PRIMARY.
  - TO CONVERT VOLTAGE FROM 240V TO 480V:
    - MOVE WIRE FROM 240V TAP TO 480V TAP AT TRANSFORMER PRIMARY.
    - IDENTIFY MODEL (i.e. AR090 OR AR120) AND REWIRE MOTOR FROM LOW VOLTAGE (240V) TO HIGH VOLTAGE (480V) ACCORDING TO INSTRUCTION BELOW.
- COLOR CODE**
- |    |        |
|----|--------|
| B  | BLACK  |
| BL | BLUE   |
| BR | BROWN  |
| G  | GREEN  |
| O  | ORANGE |
| R  | RED    |
| W  | WHITE  |
- WIRING CODE**
- |                |       |
|----------------|-------|
| FACTORY WIRING | ————— |
| HIGH VOLTAGE   | ————— |
| LOW VOLTAGE    | ————— |
| FIELD WIRING   | ————— |
| HIGH VOLTAGE   | ----- |
| LOW VOLTAGE    | ----- |

**A.O. SMITH MOTORS**

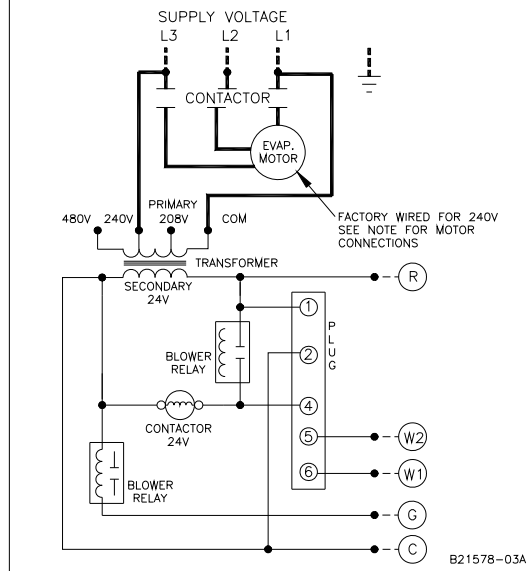
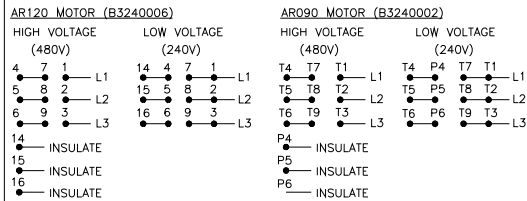

Wiring is subject to change. Always refer to the wiring diagram on the unit for the most up-to-date wiring.

**WARNING**

**HIGH VOLTAGE!**  
DISCONNECT ALL POWER BEFORE SERVICING OR INSTALLING THIS UNIT. MULTIPLE POWER SOURCES MAY BE PRESENT. FAILURE TO DO SO MAY CAUSE PROPERTY DAMAGE, PERSONAL INJURY OR DEATH.

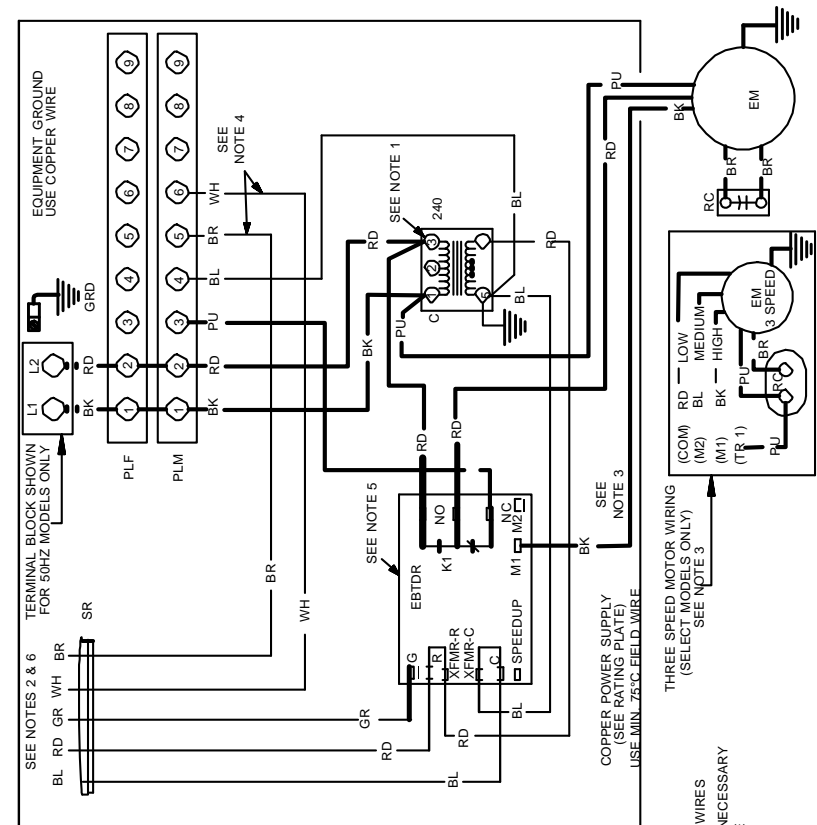
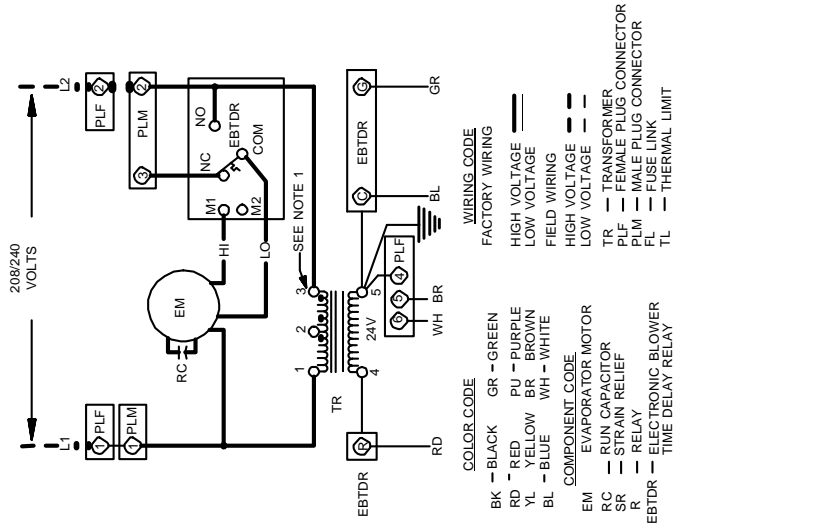

IF REPLACEMENT OF THE ORIGINAL WIRES SUPPLIED WITH THIS ASSEMBLY IS NECESSARY USE WIRE THAT CONFORMS TO THE NATIONAL ELECTRIC CODE.

- NOTES:
- 1) RED WIRES TO BE ON TRANSFORMER TERMINAL '3' FOR 240 VOLTS AND ON TERMINAL '2' FOR 208 VOLTS.
  - 2) SEE COMPONENT WIRING DIAGRAMS IN INSTALLATION INSTRUCTIONS FOR WIRING OF THE ELECTRONIC BLOWER.
  - 3) CONFIRM SPEED TAP SELECTED IS APPROPRIATE FOR APPLICATION. IF SPEED TAP NEEDS TO BE CHANGED, CONNECT APPROPRIATE MOTOR WIRE (RED FOR LOW, BLUE FOR MEDIUM, AND BLACK FOR HIGH SPEED) ON COM. CONNECTION OF THE EBTDR.
  - 4) BROWN AND WHITE WIRES ARE USED WITH HEAT KITS ONLY. EBTDR HAS A 7 SECOND ON DELAY WHEN 'G' IS ENERGIZED. THIS DELAY IS NOT ADJUSTABLE AND IS NOT TO BE SERVICED.
  - 5) LOW VOLTAGE FIELD WIRING TO BE N.E.C. GAUGE 2 WIRES.



0140A00242-A

**WARNING**

**HIGH VOLTAGE!**

DISCONNECT ALL POWER BEFORE SERVICING OR INSTALLING THIS UNIT. MULTIPLE POWER SOURCES MAY BE PRESENT. FAILURE TO DO SO MAY CAUSE PROPERTY DAMAGE, PERSONAL INJURY OR DEATH.

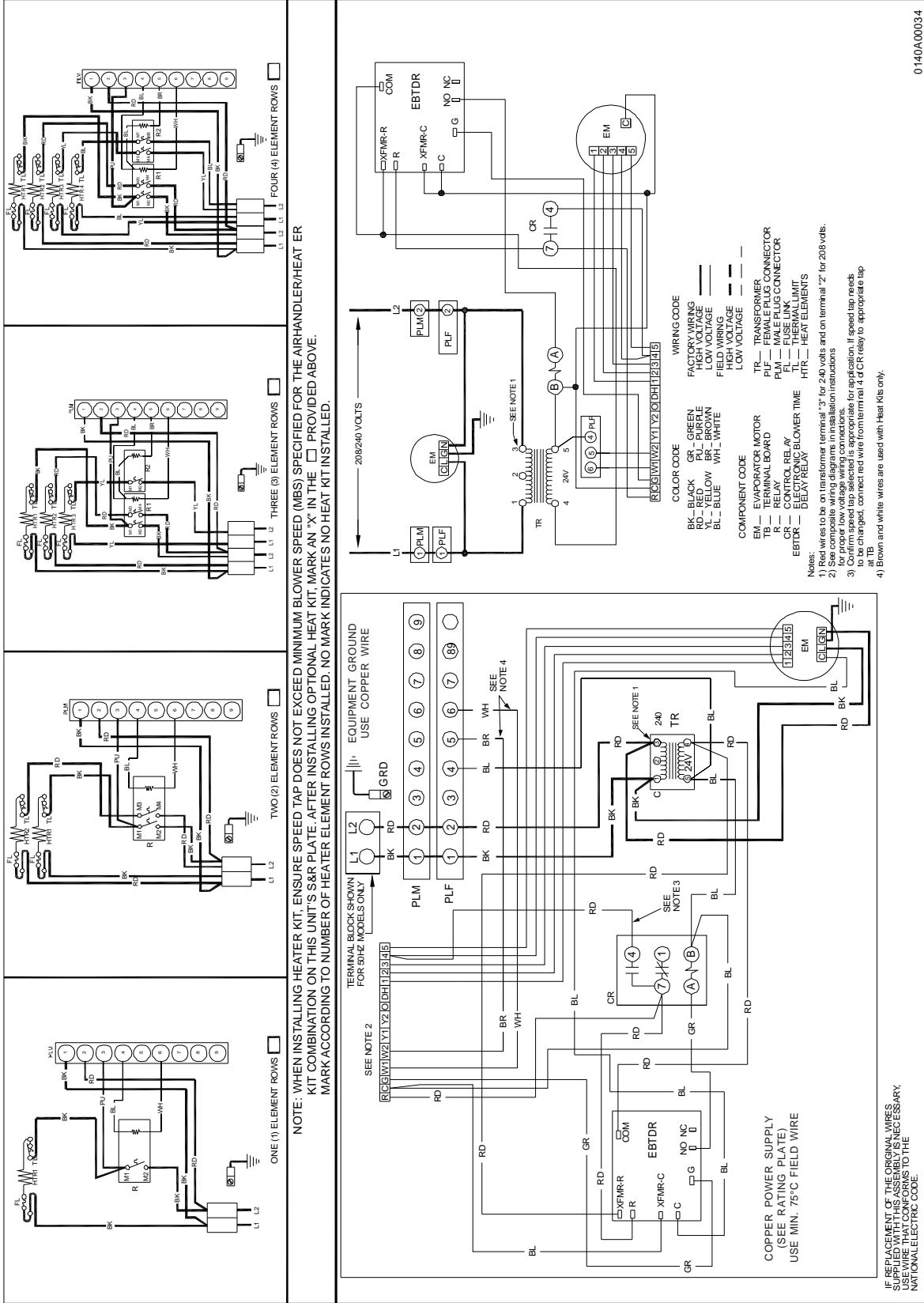

0140A.0003.4





**WARNING**  
**HIGH VOLTAGE!**  
 DISCONNECT ALL POWER BEFORE SERVICING OR INSTALLING THIS UNIT. MULTIPLE POWER SOURCES MAY BE PRESENT. FAILURE TO DO SO MAY CAUSE PROPERTY DAMAGE, PERSONAL INJURY OR DEATH.

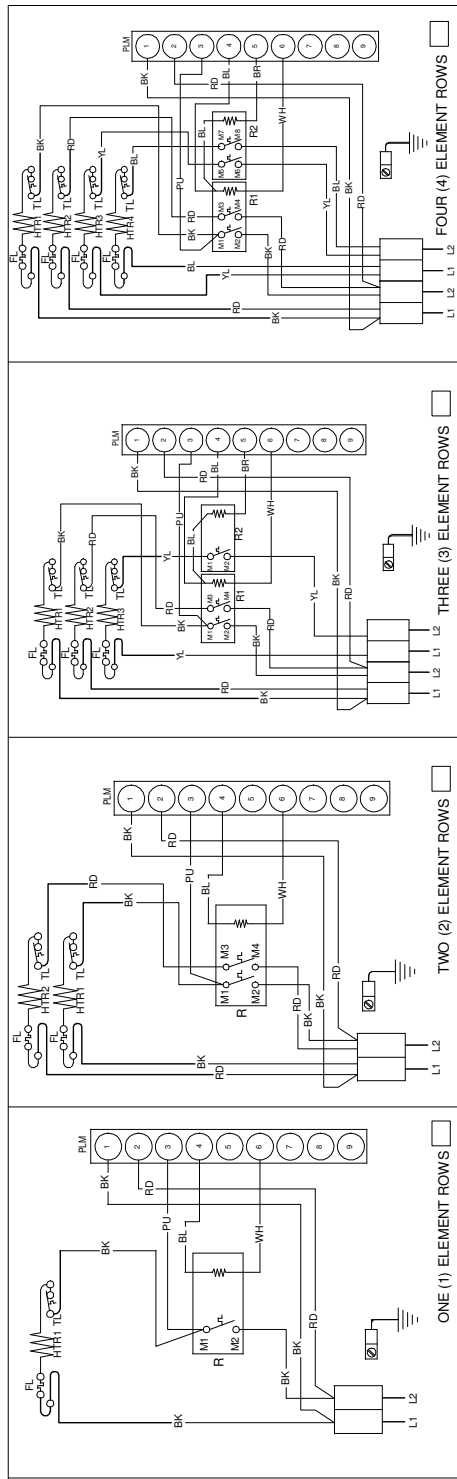

**NOTE:** WHEN INSTALLING HEATER KIT, ENSURE SPEED TAP DOES NOT EXCEED MINIMUM BLOWER SPEED (MBS) SPECIFIED FOR THE AIRHANDLER/HEATER KIT COMBINATION ON THIS UNIT'S S&R PLATE. AFTER INSTALLING OPTIONAL HEAT KIT, MARK AN "X" IN THE  PROVIDED ABOVE. MARK ACCORDING TO NUMBER OF HEATER ELEMENT ROWS INSTALLED. NO MARK INDICATES NO HEAT KIT INSTALLED.

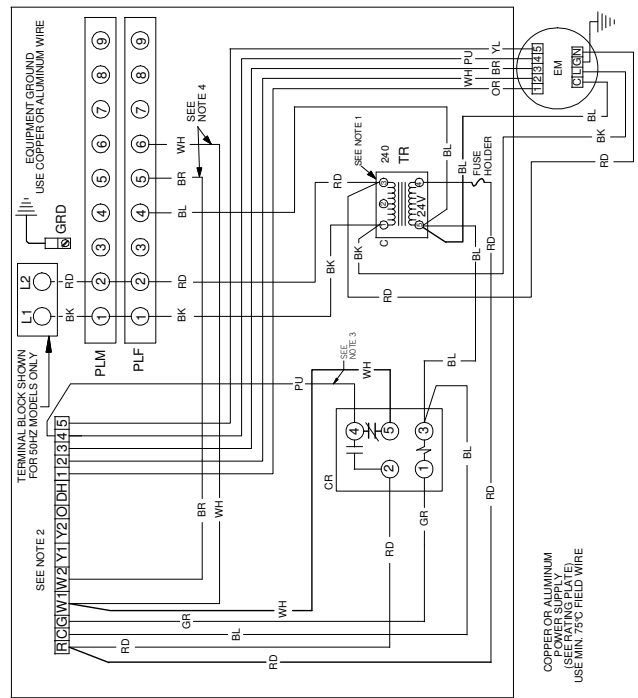

COPPER POWER SUPPLY  
 (SEE RATING PLATE)  
 USE MIN. 75°C FIELD WIRE

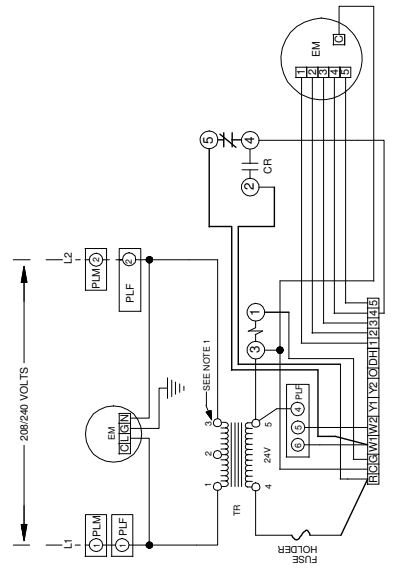

- Notes:**
- 1) Red wires to be on transformer terminal "3" for 240 volts and on terminal "2" for 208 volts.
  - 2) See complete wiring diagrams in installation instructions.
  - 3) Confirm speed tap is selected & appropriate for application. If speed tap needs to be changed, connect purple wire from terminal 4 of CR relay to appropriate tap.
  - 4) Brown and white wires are used with Heat Kits only.

0140A00037  
 REV B



**HIGH VOLTAGE!**  
 DISCONNECT ALL POWER BEFORE SERVICING OR INSTALLING THIS UNIT. MULTIPLE POWER SOURCES MAY BE PRESENT. FAILURE TO DO SO MAY CAUSE PROPERTY DAMAGE, PERSONAL INJURY OR DEATH.

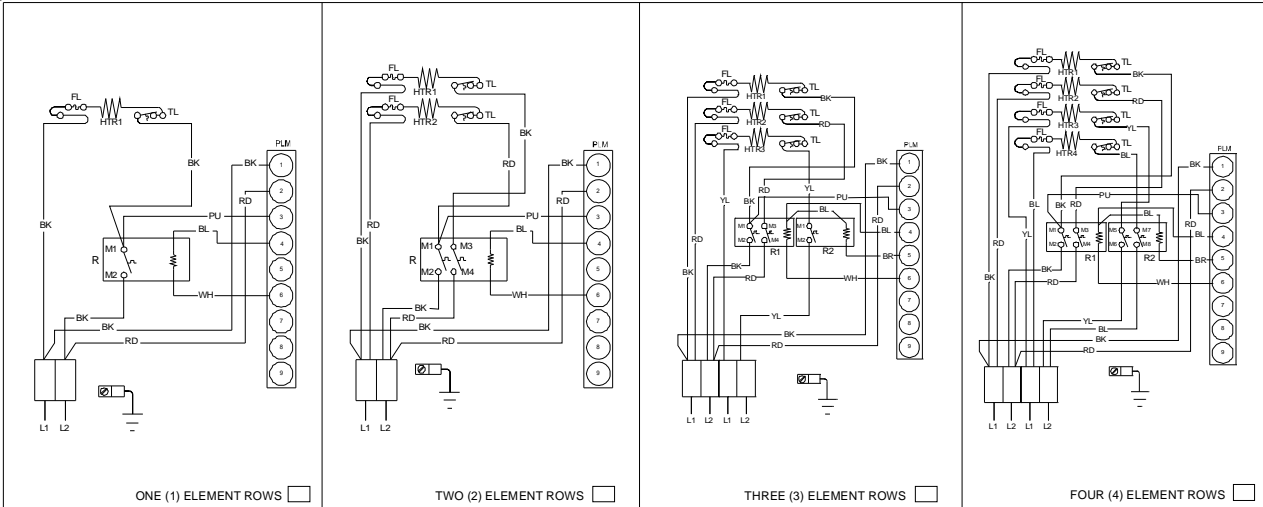

NOTE: WHEN INSTALLING HEATER KIT, ENSURE SPEED TAP DOES NOT EXCEED MINIMUM BLOWER SPEED (MBS) SPECIFIED FOR THE AIRHANDLER/HEATER KIT COMBINATION ON THIS UNIT'S S&R PLATE. AFTER INSTALLING OPTIONAL HEAT KIT, MARK AN "X" IN THE  PROVIDED ABOVE. MARK ACCORDING TO NUMBER OF HEATER ELEMENT ROWS INSTALLED. NO MARK INDICATES NO HEAT KIT INSTALLED.

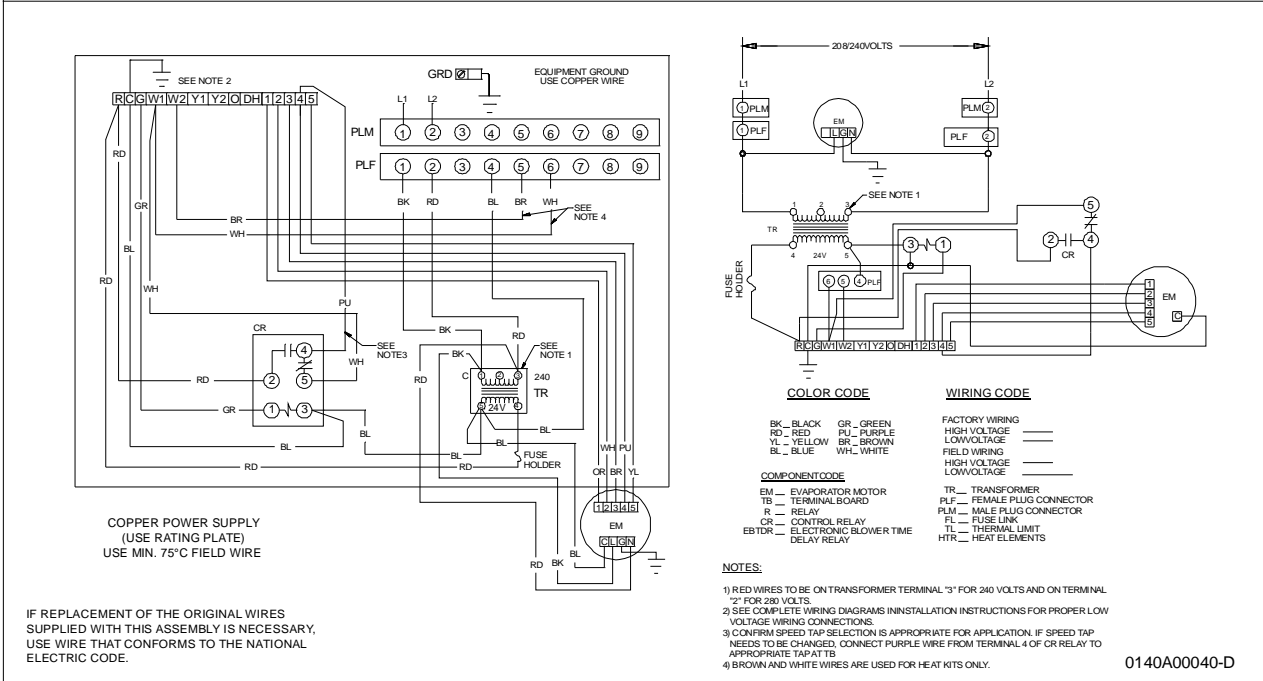

0140A00040-D

Wiring is subject to change. Always refer to the wiring diagram on the unit for the most up-to-date wiring.



**WARNING**  
**HIGH VOLTAGE!**  
 DISCONNECT ALL POWER BEFORE SERVICING OR INSTALLING THIS UNIT. MULTIPLE POWER SOURCES MAY BE PRESENT. FAILURE TO DO SO MAY CAUSE PROPERTY DAMAGE, PERSONAL INJURY OR DEATH.

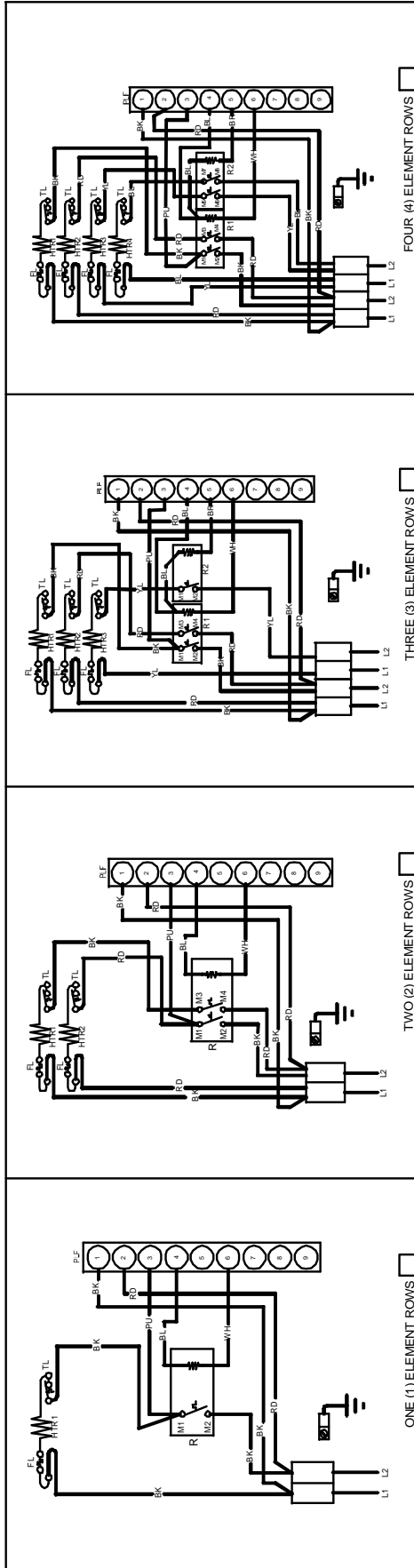

NOTE: WHEN INSTALLING HEATER KIT, ENSURE SPEED TAP DOES NOT EXCEED MINIMUM BLOWER SPEED (MBS) SPECIFIED FOR THE AIRHANDLER/HEATER KIT COMBINATION ON THIS UNIT'S SSR PLATE. AFTER INSTALLING OPTIONAL HEAT KIT, MARK A "X" IN THE BOX ACCORDING TO NUMBER OF HEATER ELEMENT ROWS INSTALLED. NO MARK INDICATES NO HEAT KIT INSTALLED.

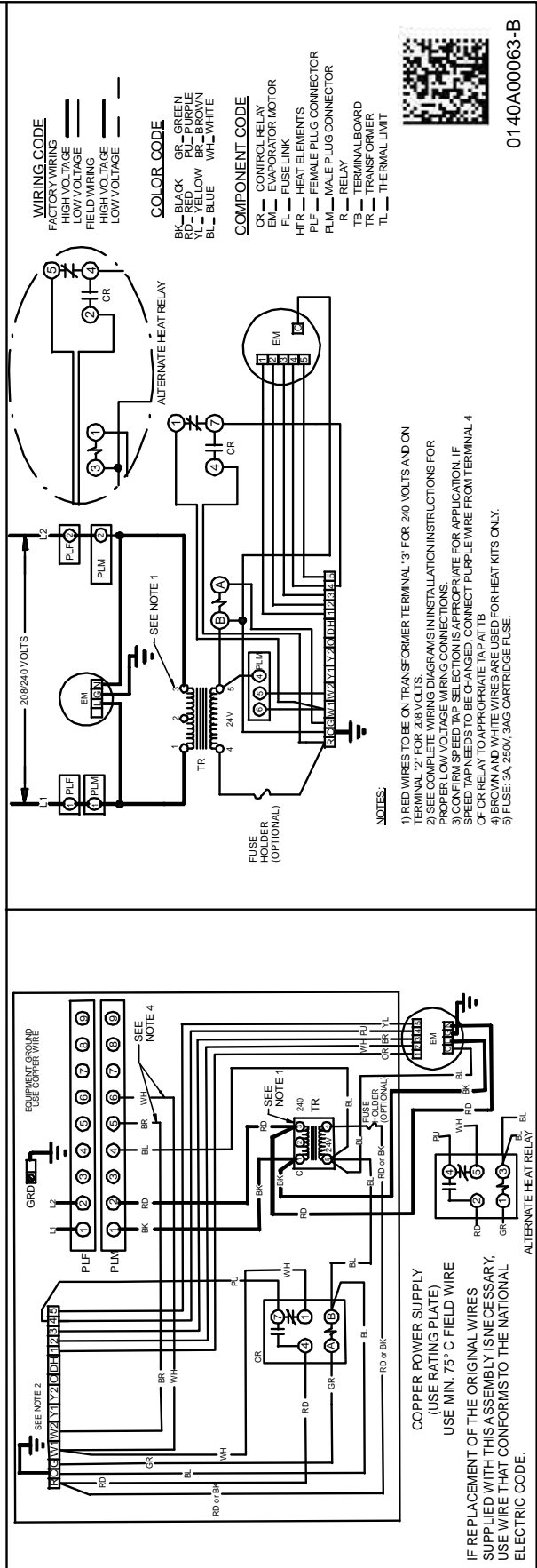

- WIRING CODE**  
 FACTORY WIRING  
 HIGH VOLTAGE  
 LOW VOLTAGE  
 FIELD WIRING  
 HIGH VOLTAGE  
 LOW VOLTAGE
- COLOR CODE**  
 BK - BLACK  
 RD - RED  
 YL - YELLOW  
 BL - BLUE  
 GR - GREEN  
 PU - PURPLE  
 BR - BROWN  
 WH - WHITE
- COMPONENT CODE**  
 CR - CONTROL RELAY  
 EM - EVAPORATOR MOTOR  
 FL - FUSE LINK  
 HFR - HEAT ELEMENTS  
 PLF - FEMALE PLUG CONNECTOR  
 PLM - MALE PLUG CONNECTOR  
 R - RELAY  
 TB - TERMINAL BOARD  
 TR - TRANSFORMER  
 TL - THERMAL LIMIT

- NOTES:**
- 1) RED WIRES TO BE ON TRANSFORMER TERMINAL "3" FOR 240 VOLTS AND ON TERMINAL "2" FOR 208 VOLTS
  - 2) SEE COMPLETE WIRING DIAGRAMS IN INSTALLATION INSTRUCTIONS FOR PROPER LOW VOLTAGE WIRING CONNECTIONS.
  - 3) CONFIRM SPEED TAP SELECTION IS APPROPRIATE FOR APPLICATION. IF SPEED TAP NEEDS TO BE CHANGED, CONNECT PURPLE WIRE FROM TERMINAL 4 OF CR RELAY TO APPROPRIATE TAP AT TB
  - 4) BROWN AND WHITE WIRES ARE USED FOR HEAT KITS ONLY.
  - 5) FUSE: 3A, 250V, 3AG CARTRIDGE FUSE.



0140A00063-B

**WARNING**

HIGH VOLTAGE!  
DISCONNECT ALL POWER BEFORE SERVICING OR INSTALLING THIS UNIT. MULTIPLE POWER SOURCES MAY BE PRESENT. FAILURE TO DO SO MAY CAUSE PROPERTY DAMAGE, PERSONAL INJURY OR DEATH.

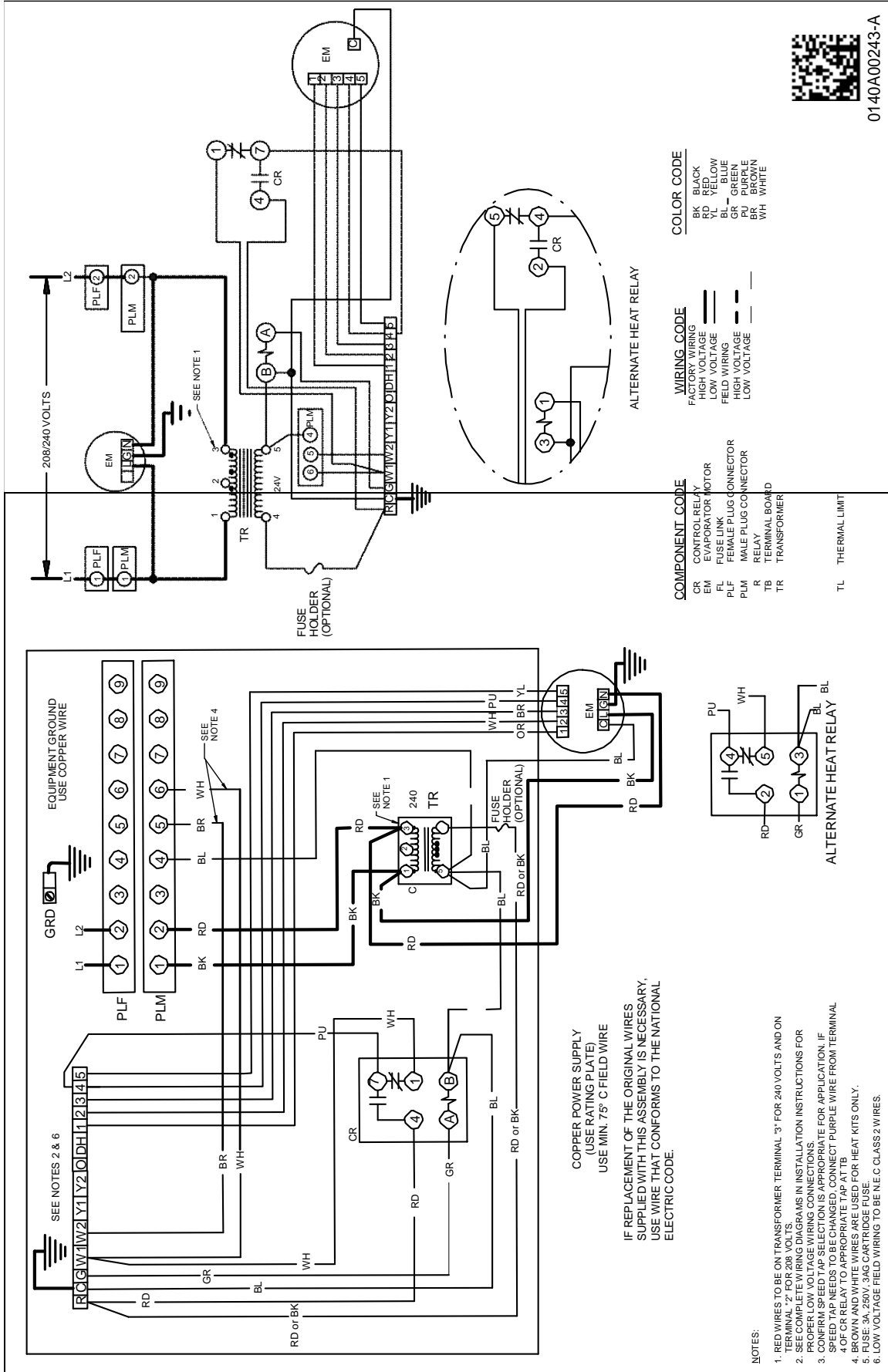

0140A00243-A

Wiring is subject to change. Always refer to the wiring diagram on the unit for the most up-to-date wiring.

# WIRING DIAGRAMS

ASPT\*\*14\*\*/ASUF\*\*14\*\*

## 3-Phase Heat Kit



**WARNING**  
HIGH VOLTAGE!  
DISCONNECT ALL POWER BEFORE SERVICING OR INSTALLING THIS UNIT. MULTIPLE POWER SOURCES MAY BE PRESENT. FAILURE TO DO SO MAY CAUSE PROPERTY DAMAGE, PERSONAL INJURY OR DEATH.

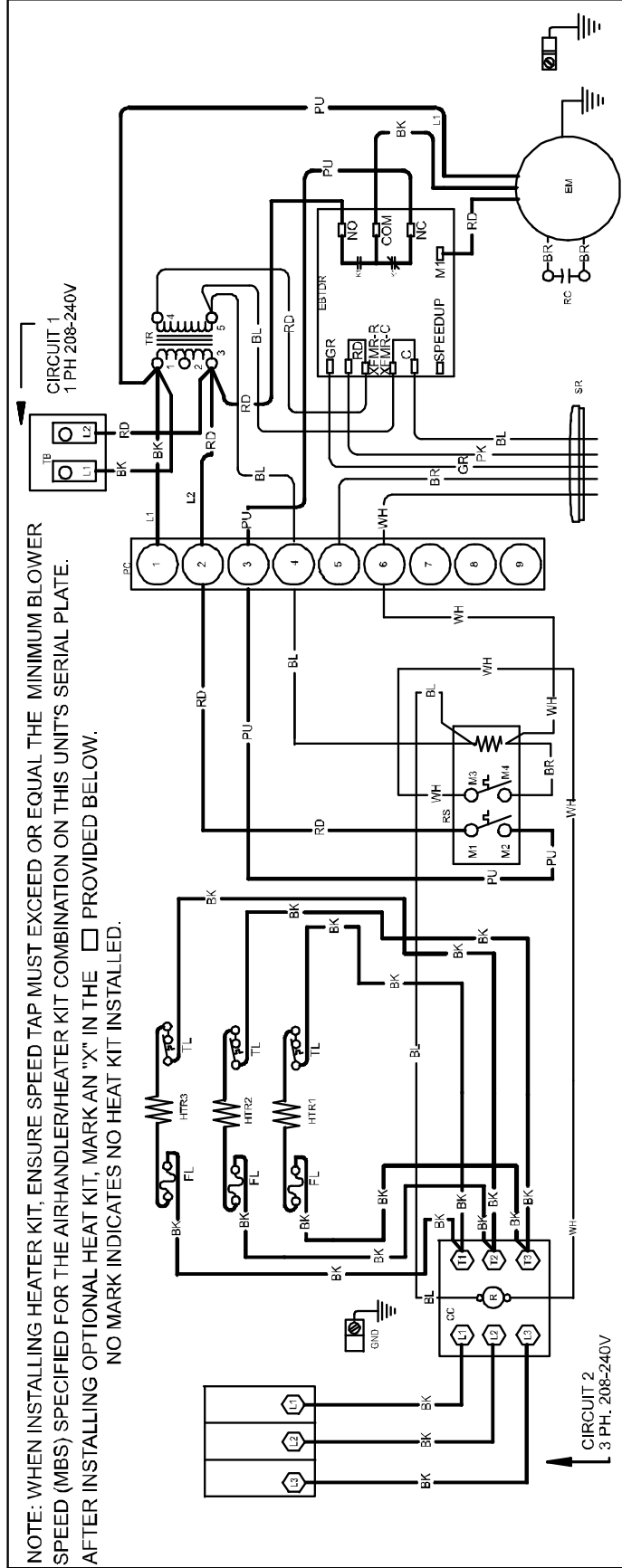

NOTE: WHEN INSTALLING HEATER KIT, ENSURE SPEED TAP MUST EXCEED OR EQUAL THE MINIMUM BLOWER SPEED (MBS) SPECIFIED FOR THE AIRHANDLER/HEATER KIT COMBINATION ON THIS UNIT'S SERIAL PLATE. AFTER INSTALLING OPTIONAL HEAT KIT, MARK AN "X" IN THE  PROVIDED BELOW. NO MARK INDICATES NO HEAT KIT INSTALLED.

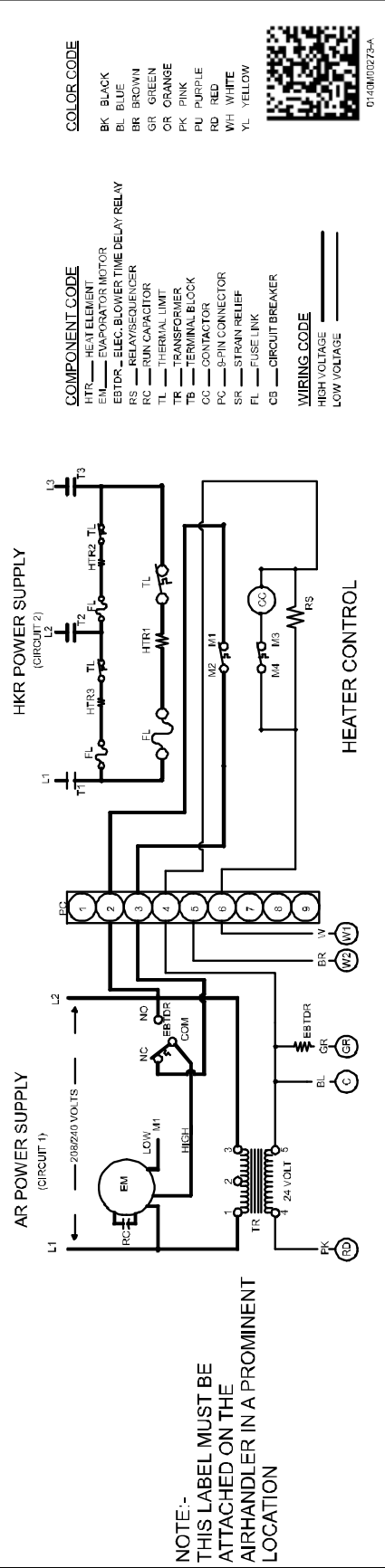

- COMPONENT CODE**
- HTR HEAT ELEMENT
  - EM EVAPORATOR MOTOR
  - EBTDR ELEC. BLOWER TIME DELAY RELAY
  - RS RELAYS/SEQUENCER
  - RC RUN CAPACITOR
  - TL THERMAL LIMIT
  - TB TRANSFORMER
  - CC CONTACTOR
  - PC 9-PIN CONNECTOR
  - SR STRAIN RELIEF
  - FL FUSE LINK
  - CB CIRCUIT BREAKER
- WIRING CODE**
- HIGH VOLTAGE \_\_\_\_\_
  - LOW VOLTAGE \_\_\_\_\_



- COLOR CODE**
- BK BLACK
  - BL BLUE
  - BR BROWN
  - GR GREEN
  - OR ORANGE
  - PK PINK
  - PU PURPLE
  - RD RED
  - WH WHITE
  - YL YELLOW

NOTE:- THIS LABEL MUST BE ATTACHED ON THE AIRHANDLER IN A PROMINENT LOCATION



**HIGH VOLTAGE!**  
 DISCONNECT ALL POWER BEFORE SERVICING OR INSTALLING THIS UNIT. MULTIPLE POWER SOURCES MAY BE PRESENT. FAILURE TO DO SO MAY CAUSE PROPERTY DAMAGE, PERSONAL INJURY OR DEATH.

**WARNING**

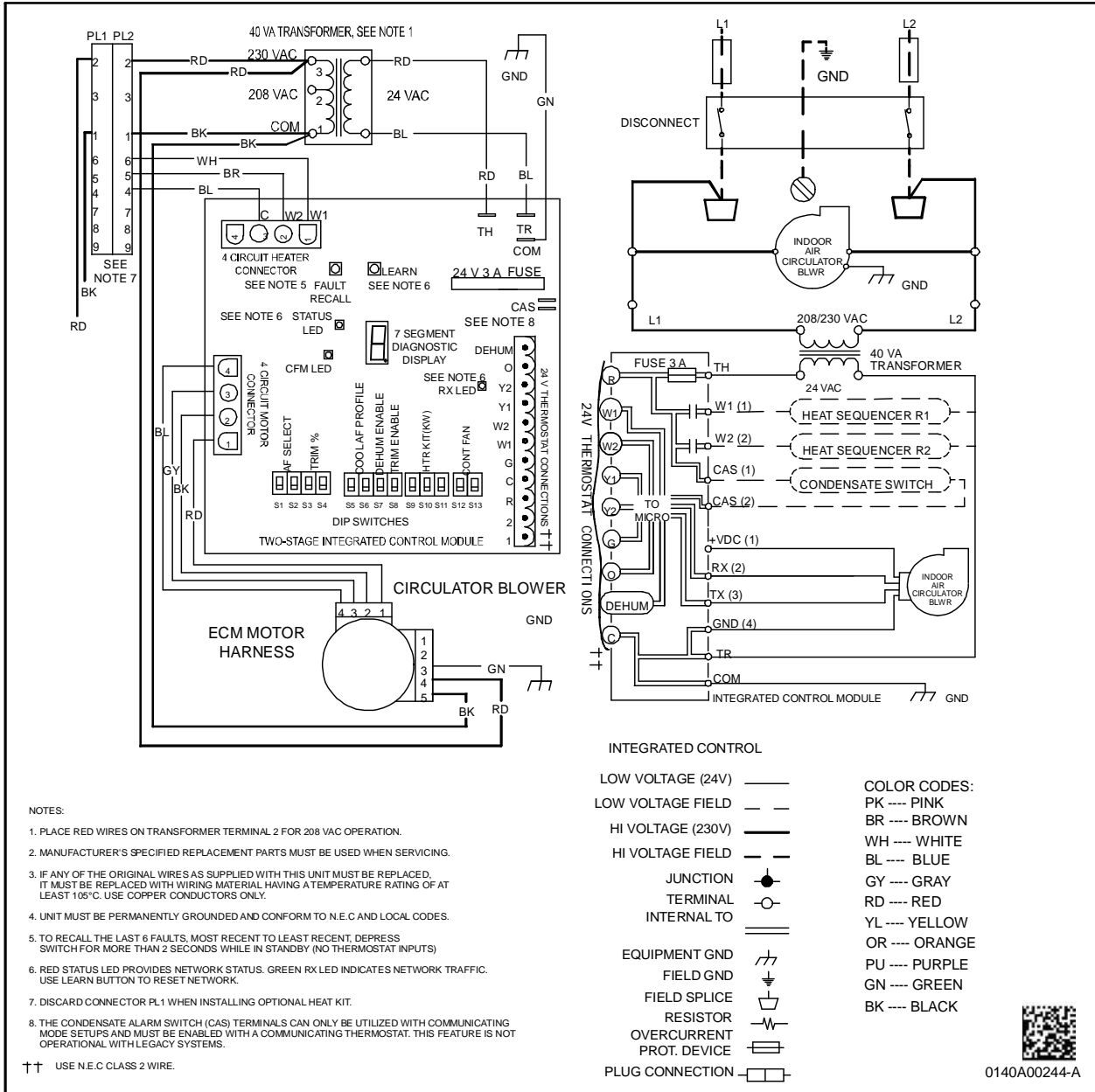

0140A00244-A













**WARNING**  
 HIGH VOLTAGE!  
 DISCONNECT ALL POWER BEFORE SERVICING OR INSTALLING THIS UNIT. MULTIPLE POWER SOURCES MAY BE PRESENT. FAILURE TO DO SO MAY CAUSE PROPERTY DAMAGE, PERSONAL INJURY OR DEATH.

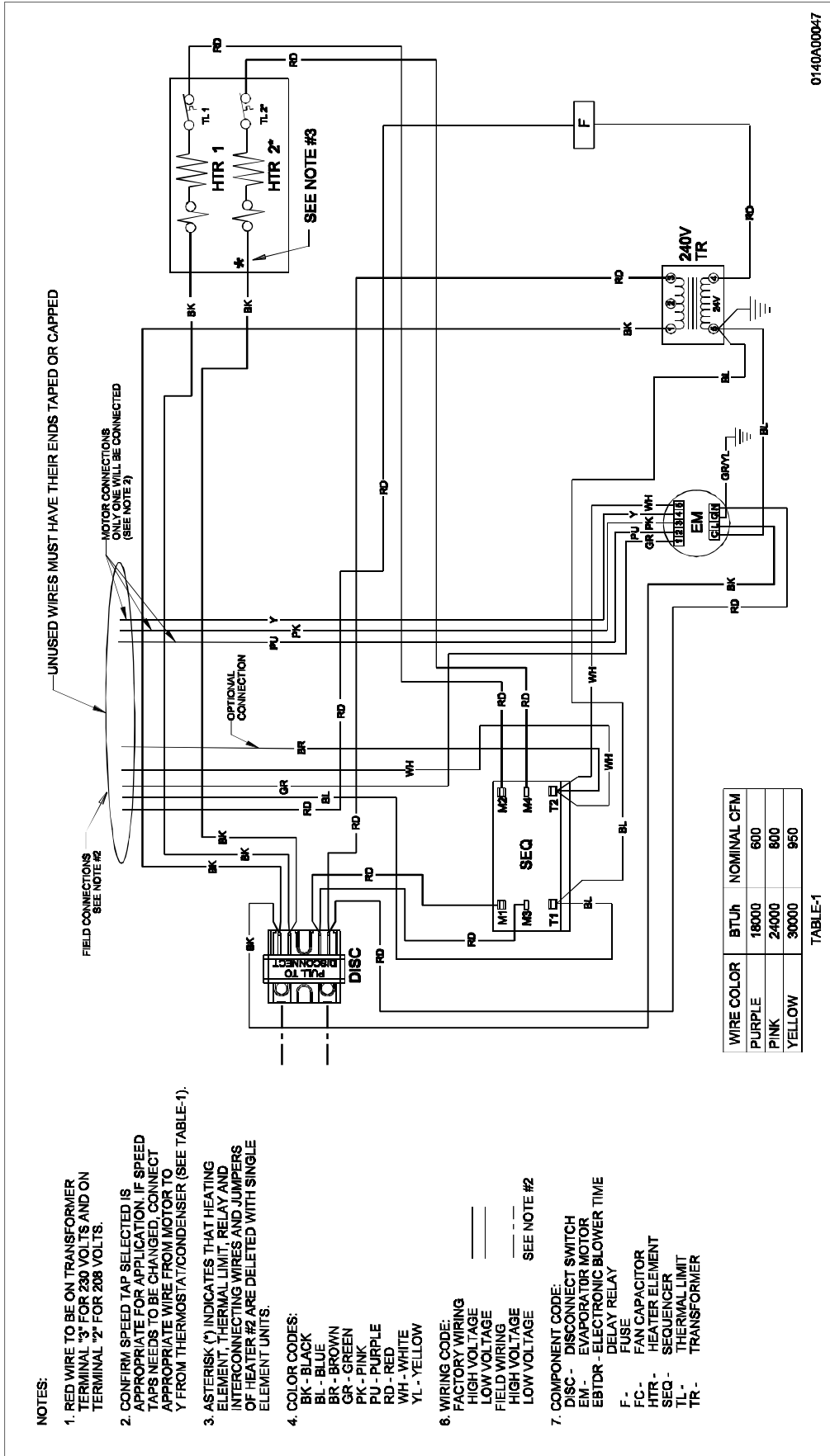

0140A00047

- NOTES:**
1. RED WIRE TO BE ON TRANSFORMER TERMINAL "3" FOR 230 VOLTS AND ON TERMINAL "2" FOR 208 VOLTS.
  2. CONFIRM SPEED TAP SELECTED IS APPROPRIATE FOR APPLICATION. IF SPEED TAPS NEEDS TO BE CHANGED, CONNECT APPROPRIATE WIRE FROM MOTOR TO Y FROM THERMOSTAT/CONDENSER (SEE TABLE-1).
  3. ASTERISK (\*) INDICATES THAT HEATING ELEMENT, THERMAL LIMIT, RELAY AND INTERCONNECTING WIRES AND JUMPERS OF HEATER #2 ARE DELETED WITH SINGLE ELEMENT UNITS.
  4. COLOR CODES:  
 BK - BLACK  
 BL - BLUE  
 BR - BROWN  
 GR - GREEN  
 PK - PINK  
 PU - PURPLE  
 RD - RED  
 WH - WHITE  
 YL - YELLOW
  5. WIRING CODE:  
 HIGH VOLTAGE  
 LOW VOLTAGE  
 FIELD WIRING  
 HIGH VOLTAGE  
 LOW VOLTAGE  
 SEE NOTE #2
  6. COMPONENT CODE:  
 DISC - DISCONNECT SWITCH  
 EM - EVAPORATOR MOTOR  
 EBTR - ELECTRONIC BLOWER TIME DELAY RELAY  
 F - FUSE  
 FC - FAN CAPACITOR  
 HTR - HEATER ELEMENT  
 SEQ - SEQUENCER  
 TL - THERMAL LIMIT  
 TR - TRANSFORMER

| WIRE COLOR | BTU/h | NOMINAL CFM |
|------------|-------|-------------|
| PURPLE     | 18000 | 600         |
| PINK       | 24000 | 800         |
| YELLOW     | 30000 | 950         |

TABLE-1

Wiring is subject to change. Always refer to the wiring diagram on the unit for the most up-to-date wiring.



# WIRING DIAGRAMS

  
**WARNING**  
HIGH VOLTAGE!  
DISCONNECT ALL POWER BEFORE SERVICING OR INSTALLING THIS UNIT. MULTIPLE POWER SOURCES MAY BE PRESENT. FAILURE TO DO SO MAY CAUSE PROPERTY DAMAGE, PERSONAL INJURY OR DEATH.

## REMOTE - SPLITS A/C

Wiring is subject to change. Always refer to the wiring diagram on the unit for the most up-to-date wiring.



**WARNING**  
**HIGH VOLTAGE!**  
 DISCONNECT ALL POWER BEFORE SERVICING OR INSTALLING THIS UNIT. MULTIPLE POWER SOURCES MAY BE PRESENT. FAILURE TO DO SO MAY CAUSE PROPERTY DAMAGE, PERSONAL INJURY OR DEATH.

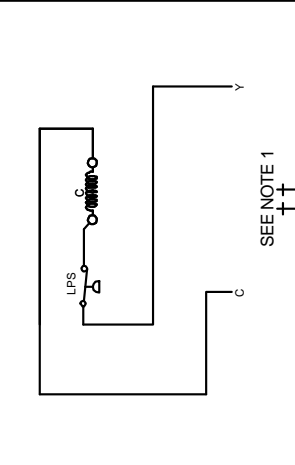
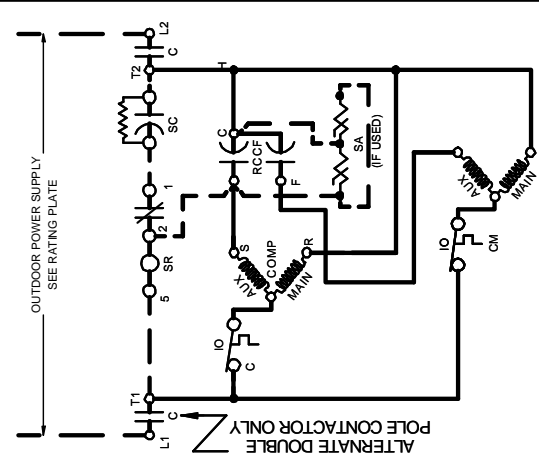
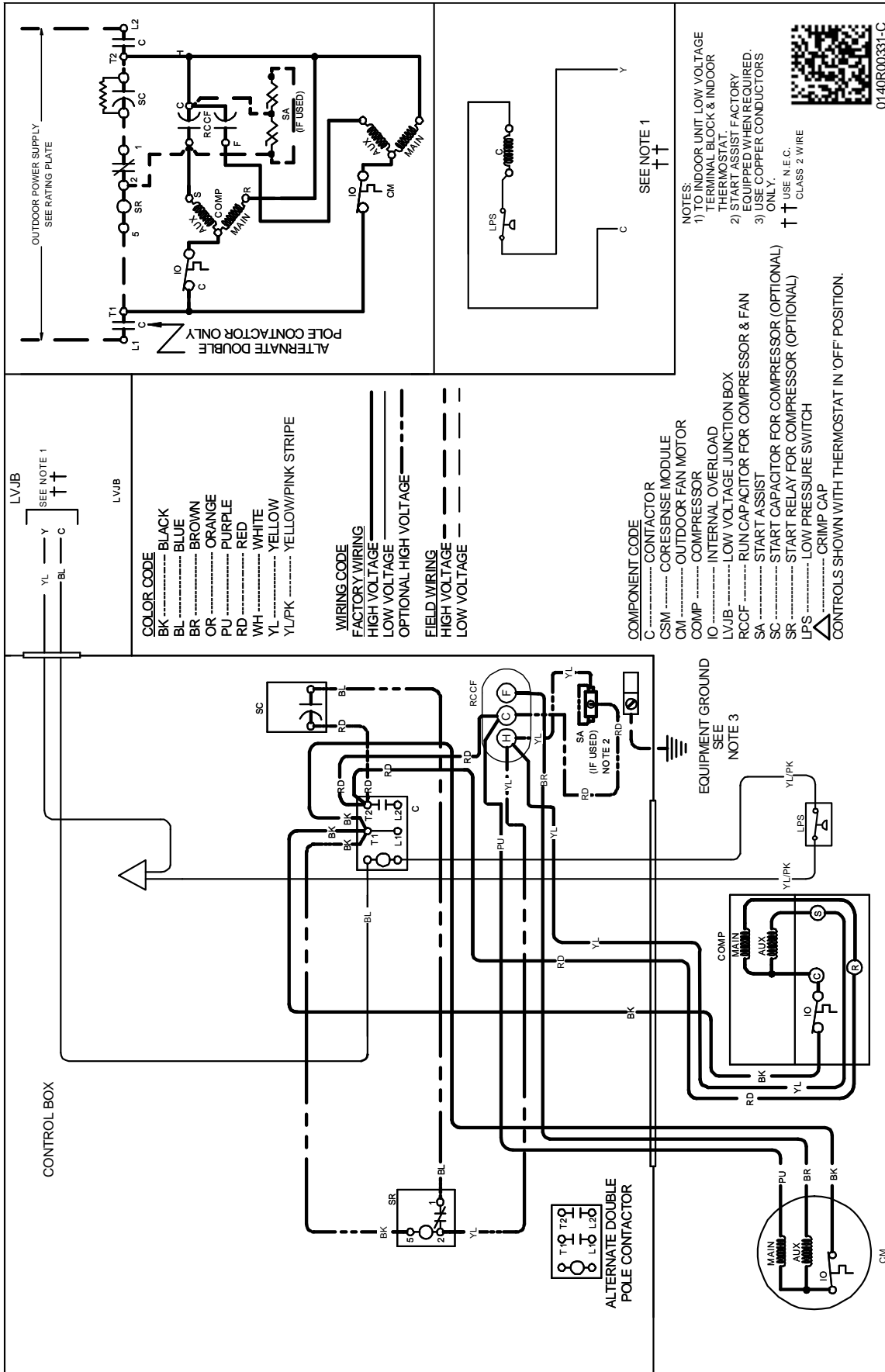

**COLOR CODE**

|       |                    |
|-------|--------------------|
| BK    | BLACK              |
| BL    | BLUE               |
| BR    | BROWN              |
| OR    | ORANGE             |
| PU    | PURPLE             |
| RD    | RED                |
| WH    | WHITE              |
| YL    | YELLOW             |
| YL/PK | YELLOW/PINK STRIPE |

**WIRING CODE**

|                       |
|-----------------------|
| FACTORY WIRING        |
| HIGH VOLTAGE          |
| LOW VOLTAGE           |
| OPTIONAL HIGH VOLTAGE |
| FIELD WIRING          |
| HIGH VOLTAGE          |
| LOW VOLTAGE           |

**COMPONENT CODE**

|           |   |
|-----------|---|
| C         | CONTACTOR                                 |
| CSM       | CORESENSE MODULE                          |
| CM        | OUTDOOR FAN MOTOR                         |
| COMP      | COMPRESSOR                                |
| IO        | INTERNAL OVERLOAD                         |
| LVJB      | LOW VOLTAGE JUNCTION BOX                  |
| RCCF      | RUN CAPACITOR FOR COMPRESSOR & FAN        |
| SA        | START ASSIST                              |
| SC        | START CAPACITOR FOR COMPRESSOR (OPTIONAL) |
| SR        | START RELAY FOR COMPRESSOR (OPTIONAL)     |
| LPS       | LOW PRESSURE SWITCH                       |
| CRIMP CAP | CRIMP CAP                                 |

**NOTES:**  
 1) TO INDOOR UNIT LOW VOLTAGE TERMINAL BLOCK & INDOOR THERMOSTAT.  
 2) START ASSIST FACTORY EQUIPPED WHEN REQUIRED ONLY.  
 3) USE COPPER CONDUCTORS ONLY.  
 † USE N.E.C. CLASS 2 WIRE



0140R00331-C

Wiring is subject to change. Always refer to the wiring diagram on the unit for the most up-to-date wiring.



**WARNING**  
**HIGH VOLTAGE!**  
 DISCONNECT ALL POWER BEFORE SERVICING OR INSTALLING THIS UNIT. MULTIPLE POWER SOURCES MAY BE PRESENT. FAILURE TO DO SO MAY CAUSE PROPERTY DAMAGE, PERSONAL INJURY OR DEATH.

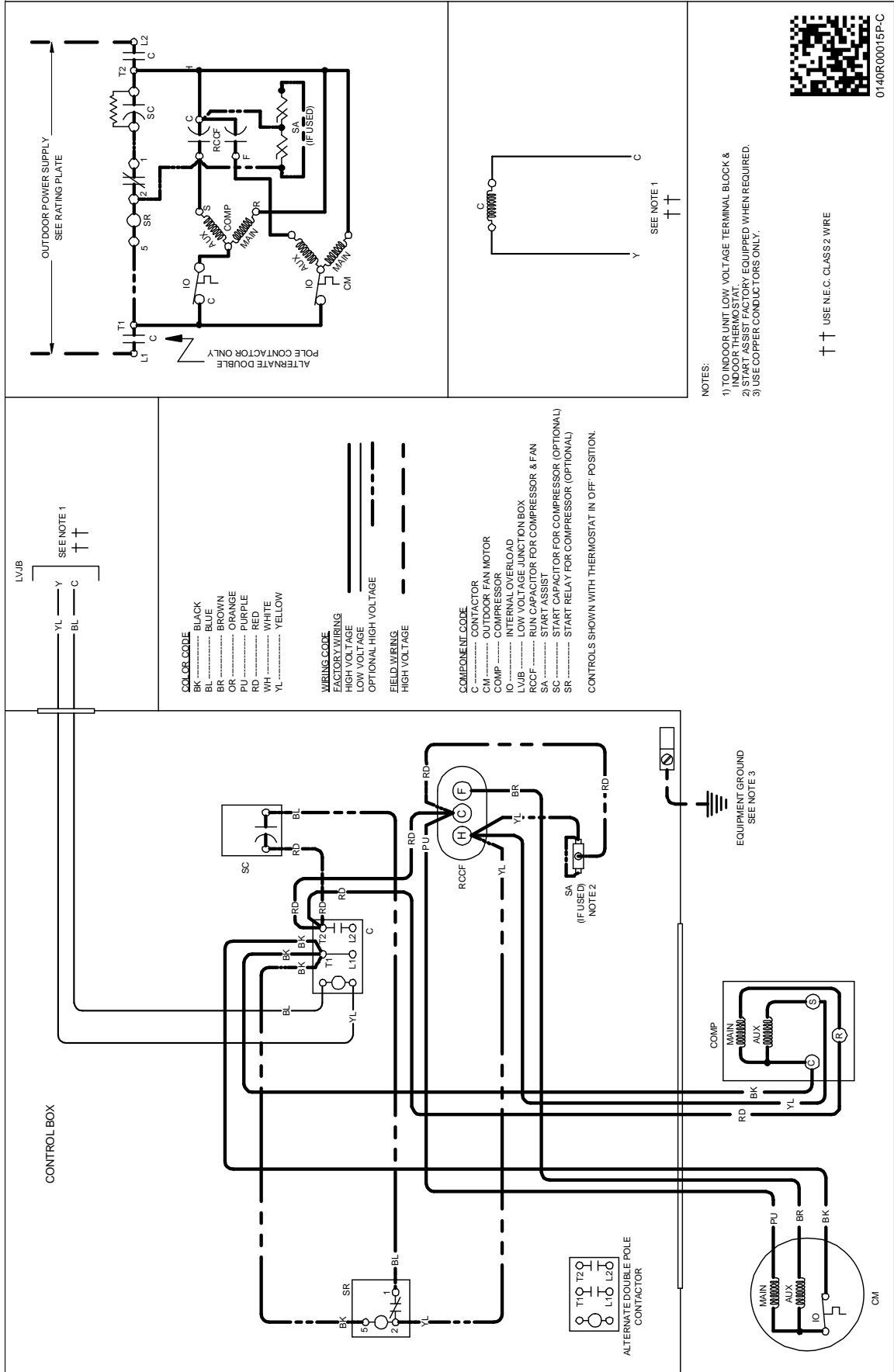

Wiring is subject to change. Always refer to the wiring diagram on the unit for the most up-to-date wiring.



**WARNING**  
**HIGH VOLTAGE!**  
 DISCONNECT ALL POWER BEFORE SERVICING OR INSTALLING THIS UNIT. MULTIPLE POWER SOURCES MAY BE PRESENT. FAILURE TO DO SO MAY CAUSE PROPERTY DAMAGE, PERSONAL INJURY OR DEATH.

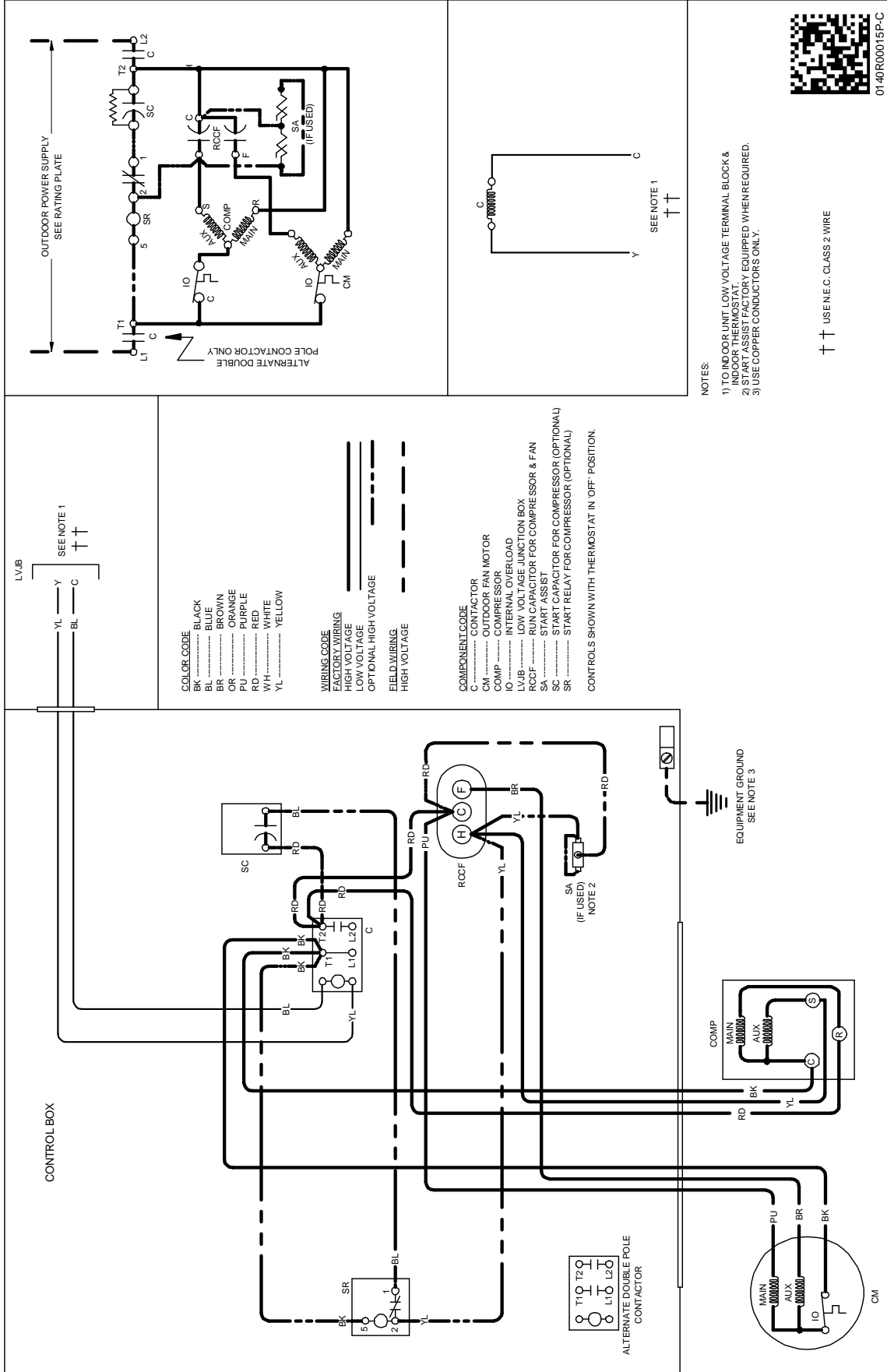

Wiring is subject to change. Always refer to the wiring diagram on the unit for the most up-to-date wiring.





**WARNING**

**HIGH VOLTAGE!**  
DISCONNECT ALL POWER BEFORE SERVICING OR INSTALLING THIS UNIT. MULTIPLE POWER SOURCES MAY BE PRESENT. FAILURE TO DO SO MAY CAUSE PROPERTY DAMAGE, PERSONAL INJURY OR DEATH.

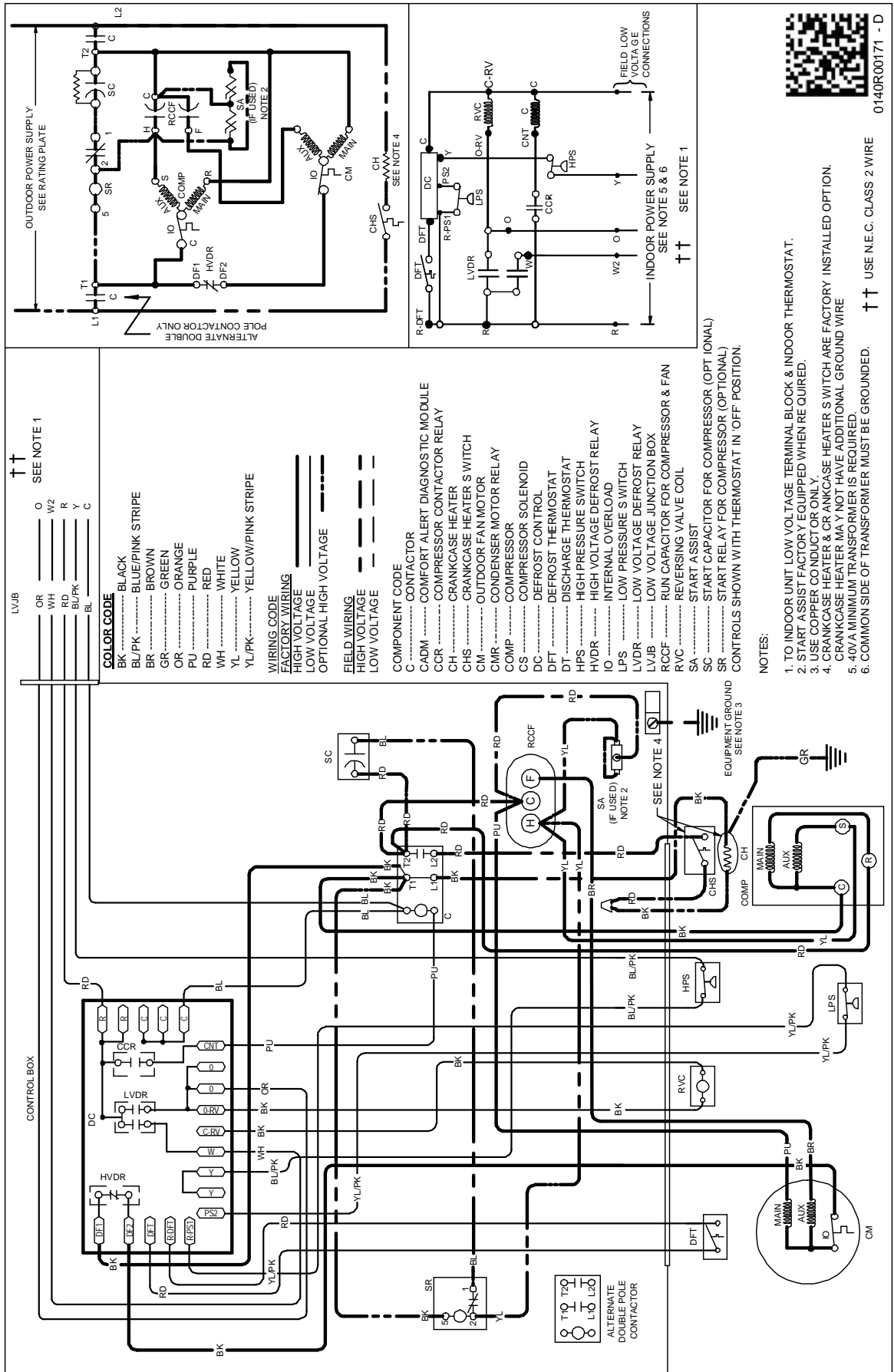

Wiring is subject to change. Always refer to the wiring diagram on the unit for the most up-to-date wiring.

LVJB

|       |    |
|-------|----|
| OR    | O  |
| WH    | W2 |
| RD    | R  |
| BL/PK | Y  |
| BL    | C  |

↑↑ SEE NOTE 1

**COLOR CODE**

|       |                    |
|-------|--------------------|
| BL    | BLACK              |
| BL/PK | BLUE/PINK STRIPE   |
| BR    | BROWN              |
| GR    | GREEN              |
| OR    | ORANGE             |
| PU    | PURPLE             |
| RD    | RED                |
| WH    | WHITE              |
| YL    | YELLOW             |
| YL/PK | YELLOW/PINK STRIPE |

**WIRING CODE**

|     |                       |
|-----|-----------------------|
| --- | FACTORY WIRING        |
| --- | HIGH VOLTAGE          |
| --- | LOW VOLTAGE           |
| --- | OPTIONAL HIGH VOLTAGE |

**FIELD WIRING**

|     |              |
|-----|--------------|
| --- | HIGH VOLTAGE |
| --- | LOW VOLTAGE  |

- COMPONENT CODE**
- C..... CONTACTOR
  - CADM..... COMFORT ALERT DIAGNOSTIC MODULE
  - CCR..... COMPRESSOR CONTACTOR RELAY
  - CH..... CRANKCASE HEATER
  - CHS..... CRANKCASE HEATER SWITCH
  - CM..... OUTDOOR FAN MOTOR
  - CMR..... CONDENSER MOTOR RELAY
  - COMP..... COMPRESSOR SOLENOID
  - DC..... DEFROST CONTROL
  - DFT..... DEFROST THERMOSTAT
  - DT..... DISCHARGE THERMOSTAT
  - HPS..... HIGH PRESSURE SWITCH
  - HVD..... HIGH VOLTAGE DEFROST RELAY
  - IO..... INTERNAL OVERLOAD
  - LPS..... LOW PRESSURE SWITCH
  - LVDR..... LOW VOLTAGE DEFROST RELAY
  - LVJB..... LOW VOLTAGE JUNCTION BOX
  - RVC..... RUN CAPACITOR FOR COMPRESSOR & FAN
  - RCCF..... REVERSING VALVE COIL
  - SA..... START ASSIST
  - SC..... START CAPACITOR FOR COMPRESSOR (OPTIONAL)
  - SR..... START RELAY FOR COMPRESSOR (OPTIONAL)
- CONTROLS SHOWN WITH THERMOSTAT IN 'OFF' POSITION.

- NOTES:**
1. TO INDOOR UNIT LOW VOLTAGE TERMINAL BLOCK & INDOOR THERMOSTAT.
  2. START ASSIST FACTORY EQUIPPED WHEN REQUIRED.
  3. USE COPPER CONDUCTOR ONLY.
  4. CRANKCASE HEATER & CRANKCASE HEATER SWITCH ARE FACTORY INSTALLED OPTION.
  5. 40VA MINIMUM TRANSFORMER IS REQUIRED.
  6. COMMON SIDE OF TRANSFORMER MUST BE GROUNDED.



0140R00171 - D



**WARNING**  
**HIGH VOLTAGE!**  
 DISCONNECT ALL POWER BEFORE SERVICING OR INSTALLING THIS UNIT. MULTIPLE POWER SOURCES MAY BE PRESENT. FAILURE TO DO SO MAY CAUSE PROPERTY DAMAGE, PERSONAL INJURY OR DEATH.

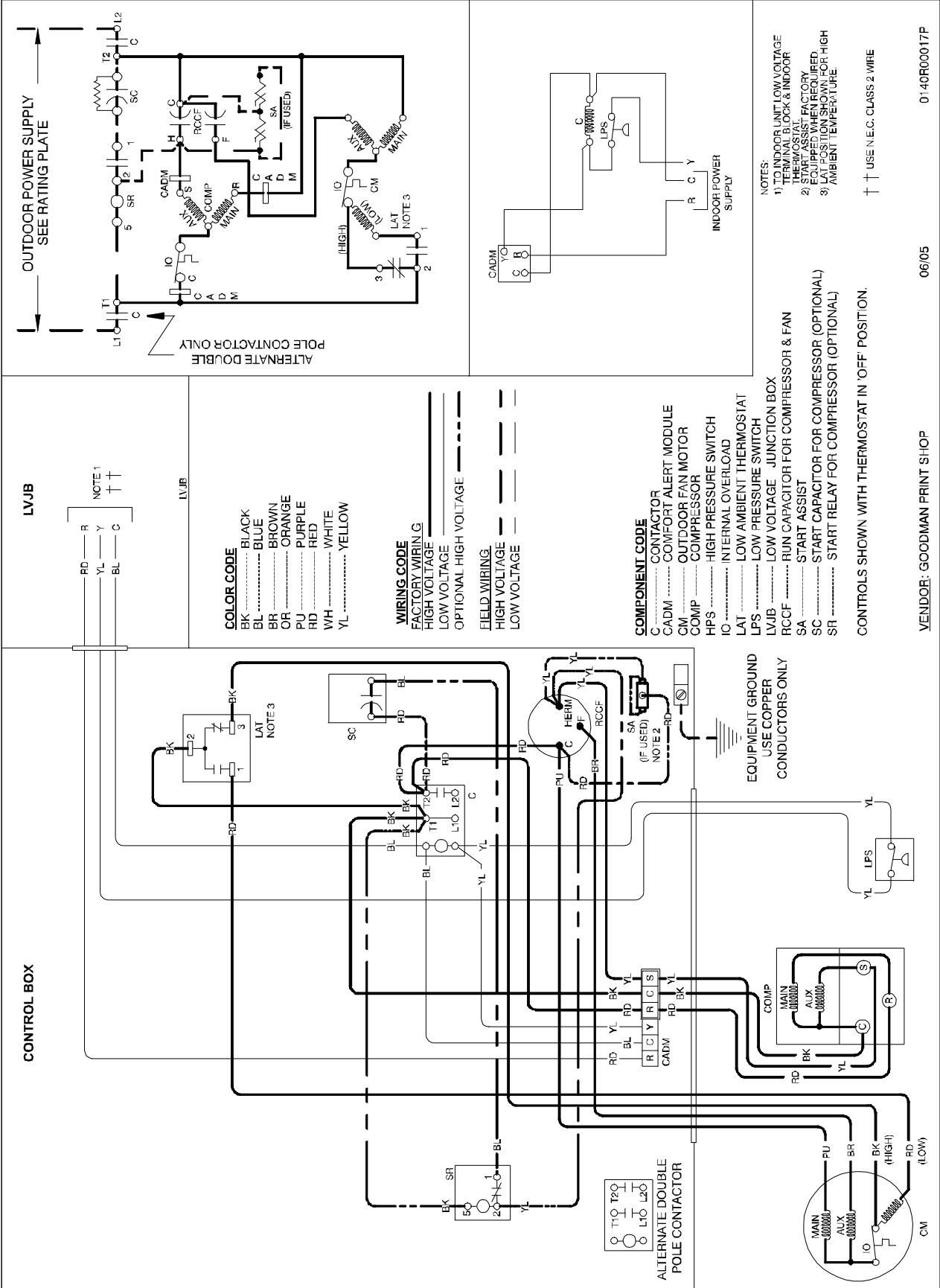

0140R00017P

06/05

VENDOR: GOODMAN PRINT SHOP

Wiring is subject to change. Always refer to the wiring diagram on the unit for the most up-to-date wiring.

**WARNING**  
 HIGH VOLTAGE!  
 DISCONNECT ALL POWER BEFORE SERVICING OR INSTALLING THIS UNIT. MULTIPLE POWER SOURCES MAY BE PRESENT. FAILURE TO DO SO MAY CAUSE PROPERTY DAMAGE, PERSONAL INJURY OR DEATH.

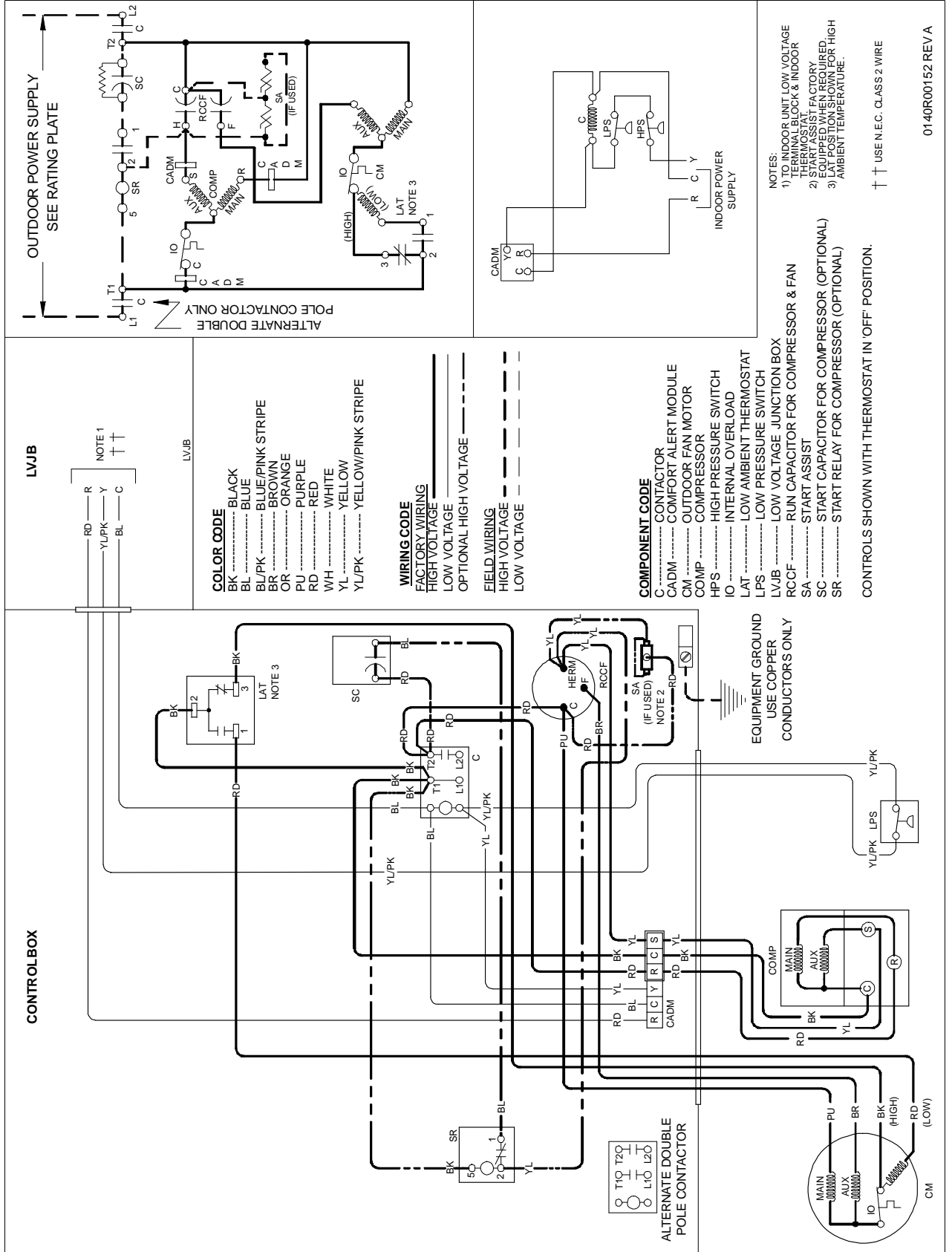

Wiring is subject to change. Always refer to the wiring diagram on the unit for the most up-to-date wiring.



**WARNING**  
**HIGH VOLTAGE!**  
 DISCONNECT ALL POWER BEFORE SERVICING OR INSTALLING THIS UNIT. MULTIPLE POWER SOURCES MAY BE PRESENT. FAILURE TO DO SO MAY CAUSE PROPERTY DAMAGE, PERSONAL INJURY OR DEATH.

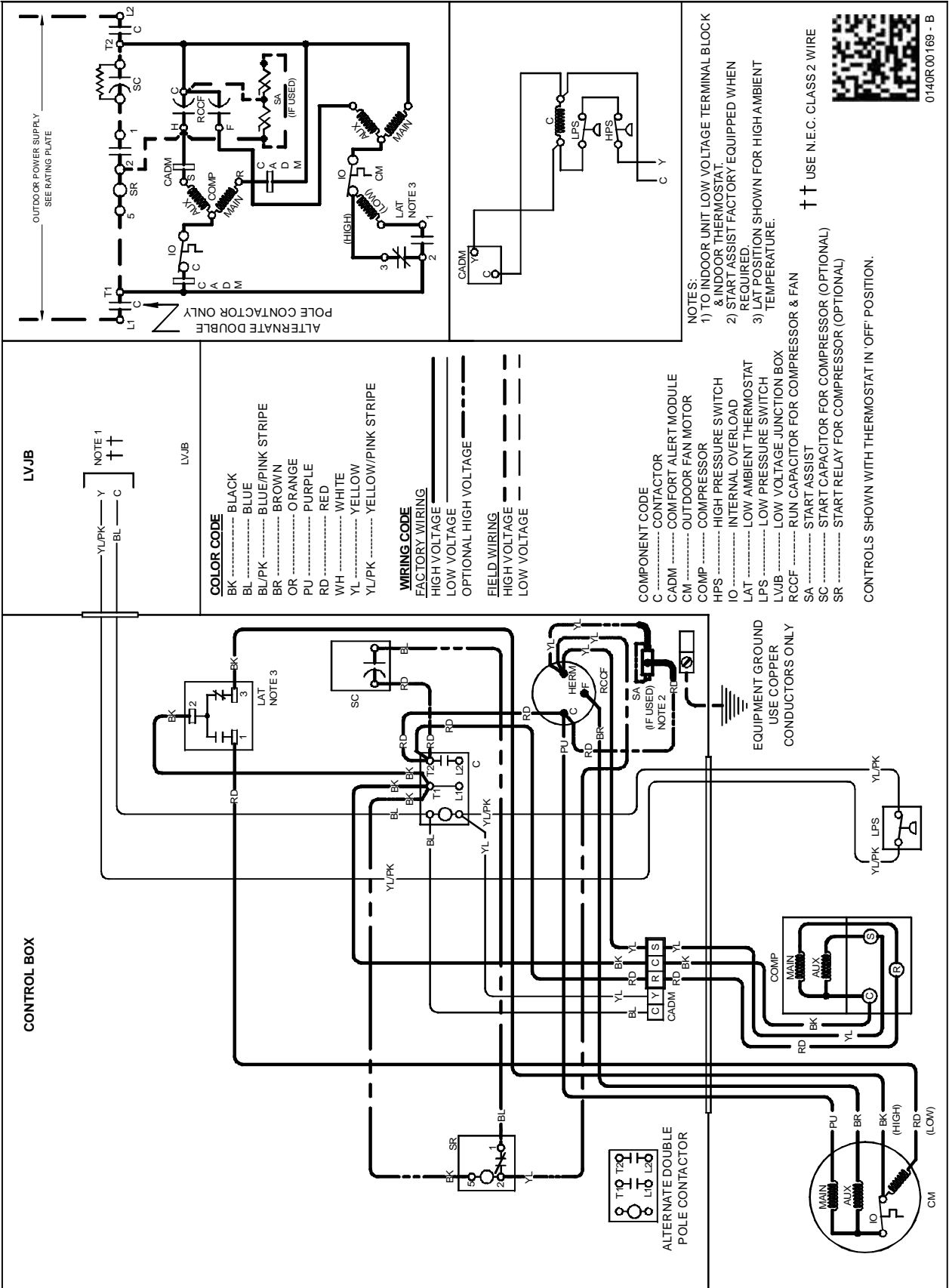

Wiring is subject to change. Always refer to the wiring diagram on the unit for the most up-to-date wiring.

# WIRING DIAGRAMS

ASX130[24-48]1CC / ASX130601CB / ASX130611A \*  
/ ASX130[18, 36]1D \*



**WARNING**  
HIGH VOLTAGE!  
DISCONNECT ALL POWER BEFORE SERVICING OR INSTALLING THIS UNIT. MULTIPLE POWER SOURCES MAY BE PRESENT. FAILURE TO DO SO MAY CAUSE PROPERTY DAMAGE, PERSONAL INJURY OR DEATH.

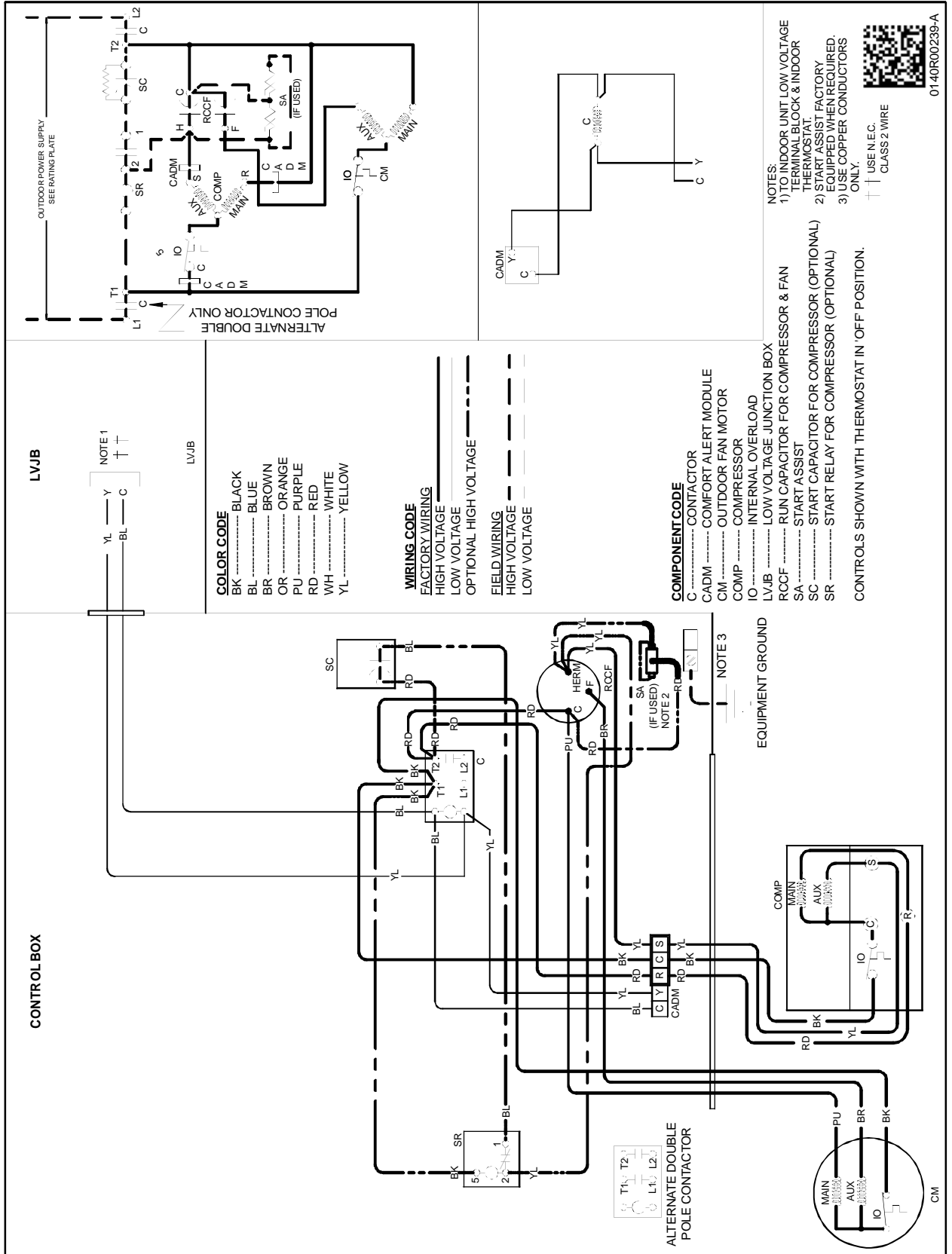

0140R00239-A

Wiring is subject to change. Always refer to the wiring diagram on the unit for the most up-to-date wiring.

WIRING DIAGRAMS

**WARNING**

**HIGH VOLTAGE!**  
DISCONNECT ALL POWER BEFORE SERVICING OR INSTALLING THIS UNIT. MULTIPLE POWER SOURCES MAY BE PRESENT. FAILURE TO DO SO MAY CAUSE PROPERTY DAMAGE, PERSONAL INJURY OR DEATH.

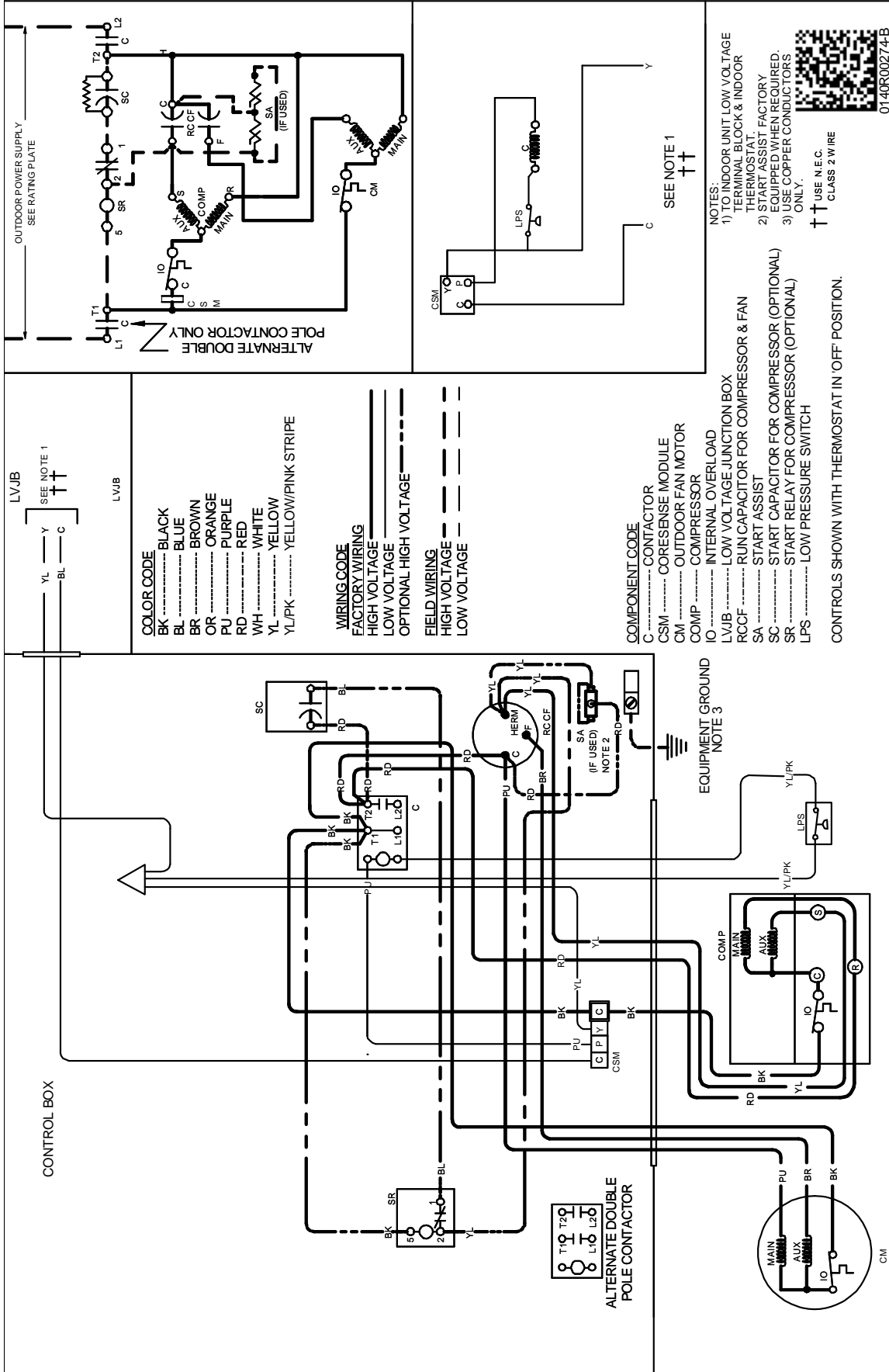

Wiring is subject to change. Always refer to the wiring diagram on the unit for the most up-to-date wiring.

**WARNING**  
**HIGH VOLTAGE!**  
 DISCONNECT ALL POWER BEFORE SERVICING OR INSTALLING THIS UNIT. MULTIPLE POWER SOURCES MAY BE PRESENT. FAILURE TO DO SO MAY CAUSE PROPERTY DAMAGE, PERSONAL INJURY OR DEATH.

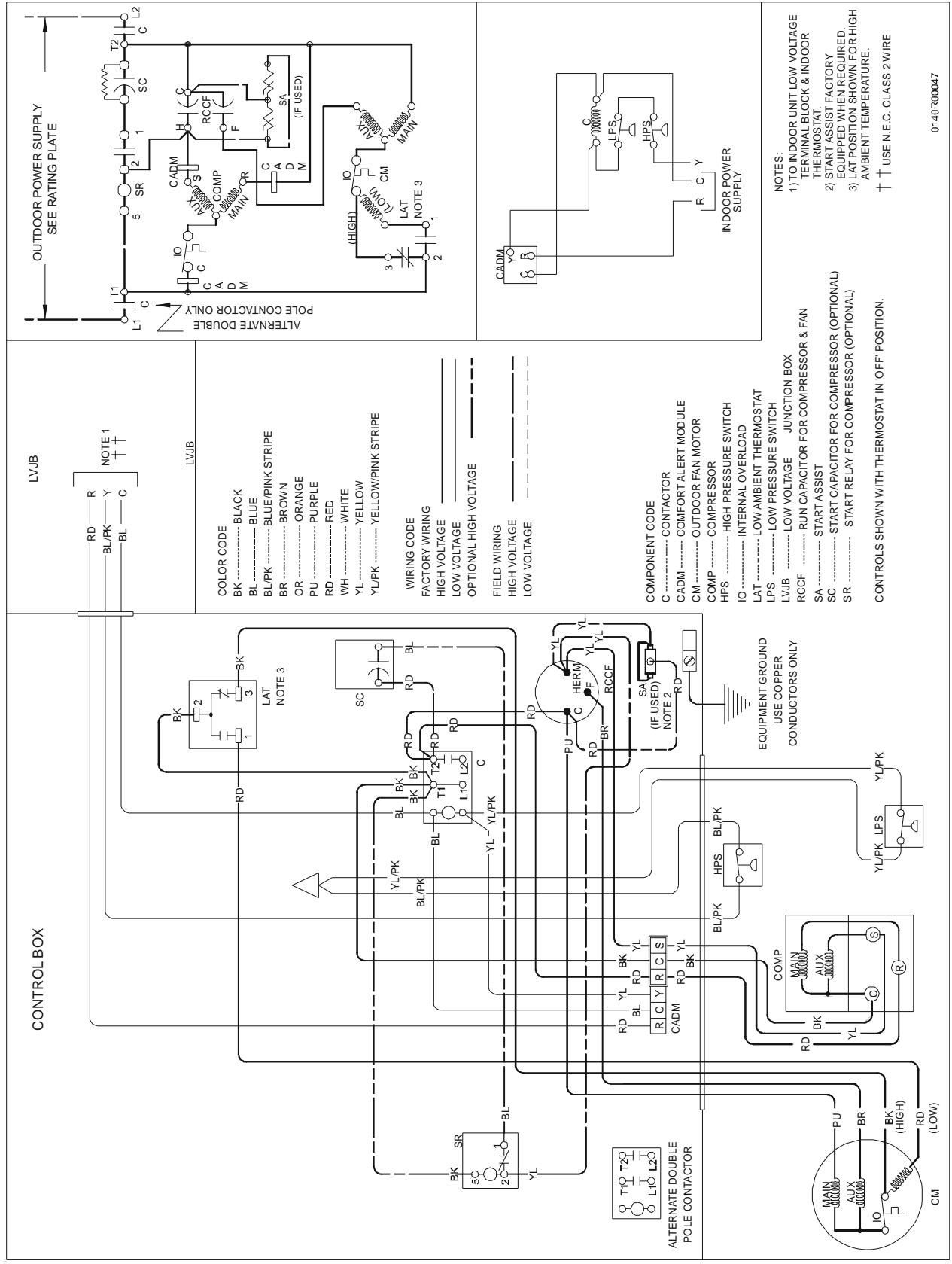

0140R00047

Wiring is subject to change. Always refer to the wiring diagram on the unit for the most up-to-date wiring.

# WIRING DIAGRAMS

## ASX140[18-36/48]1C[A/B] ASX140421D[A/B] / ASX140[48-60]1[BA/B]



**WARNING**  
HIGH VOLTAGE!  
DISCONNECT ALL POWER BEFORE SERVICING OR INSTALLING THIS UNIT. MULTIPLE POWER SOURCES MAY BE PRESENT. FAILURE TO DO SO MAY CAUSE PROPERTY DAMAGE, PERSONAL INJURY OR DEATH.

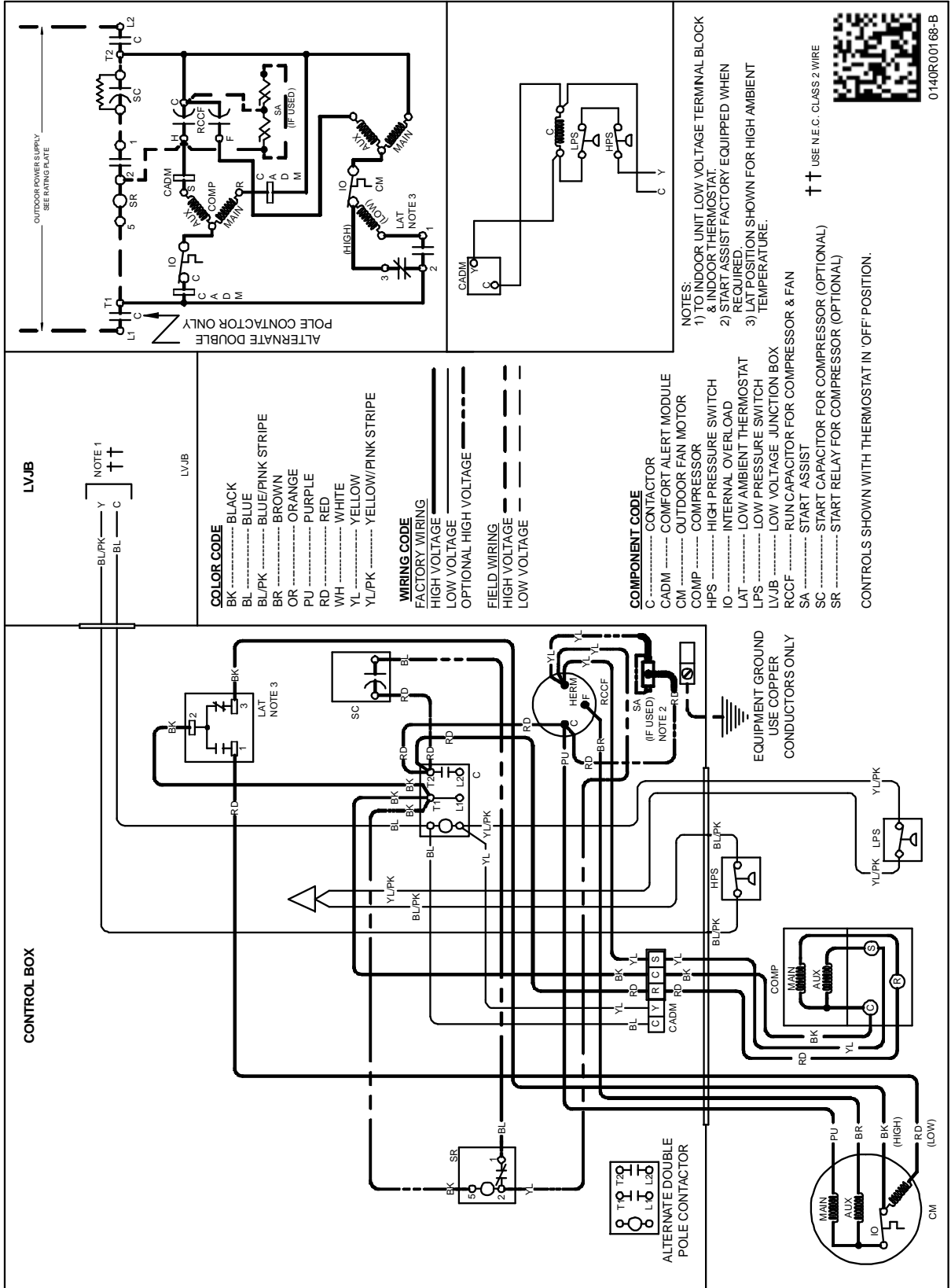



# WIRING DIAGRAMS

ASX140[24-36]1CC / ASX140421DC  
 ASX140481CB / ASX140601BC / ASX1401801DA

**WARNING**  
 HIGH VOLTAGE!  
 DISCONNECT ALL POWER BEFORE SERVICING OR INSTALLING THIS UNIT. MULTIPLE POWER SOURCES MAY BE PRESENT. FAILURE TO DO SO MAY CAUSE PROPERTY DAMAGE, PERSONAL INJURY OR DEATH.

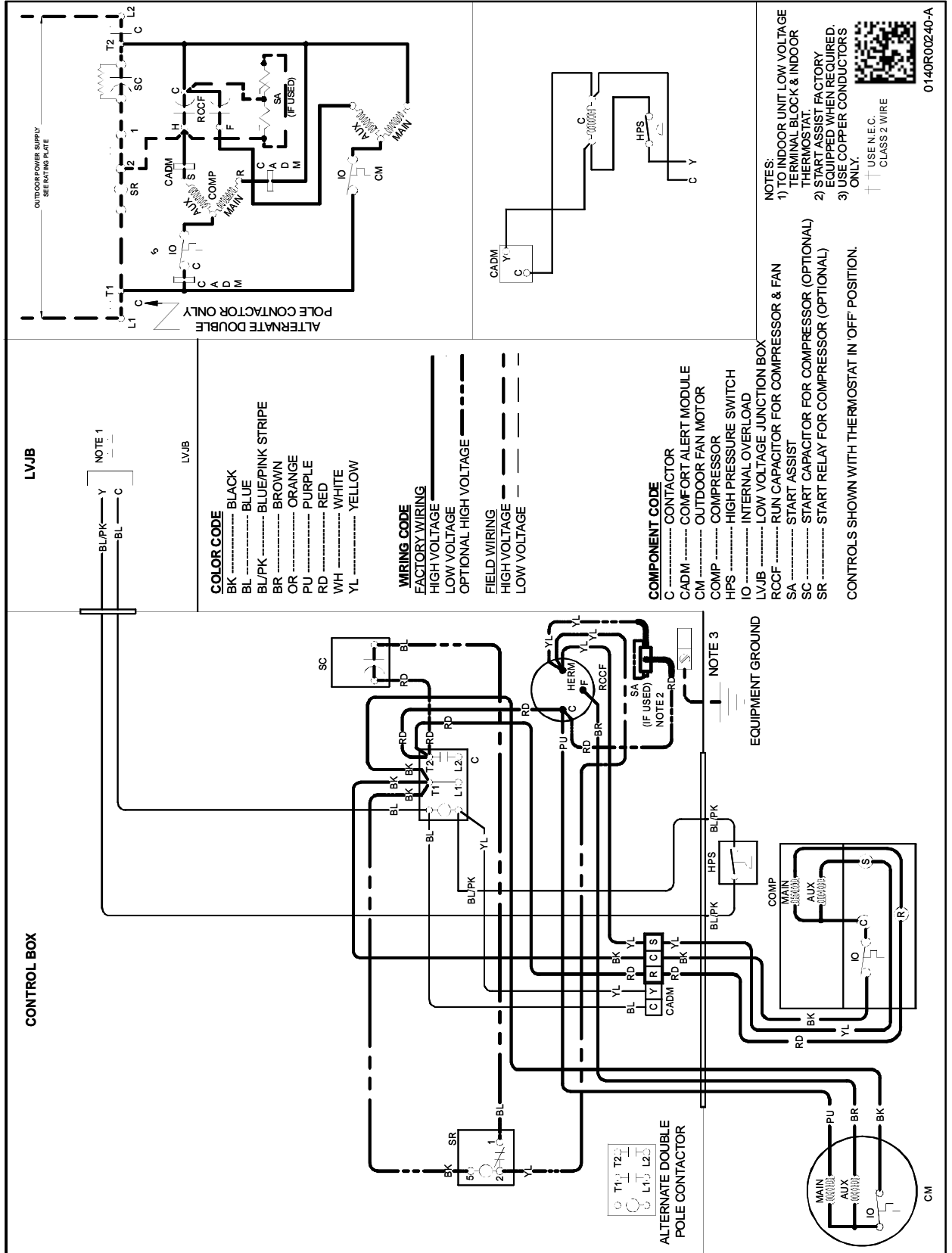

Wiring is subject to change. Always refer to the wiring diagram on the unit for the most up-to-date wiring.

# WIRING DIAGRAMS

## ASX140[24-36]1CD/ASX140421DD ASX140481CC/ASX140601BD/ASX1401801DB



**WARNING**  
HIGH VOLTAGE!  
DISCONNECT ALL POWER BEFORE SERVICING OR INSTALLING THIS UNIT. MULTIPLE POWER SOURCES MAY BE PRESENT. FAILURE TO DO SO MAY CAUSE PROPERTY DAMAGE, PERSONAL INJURY OR DEATH.

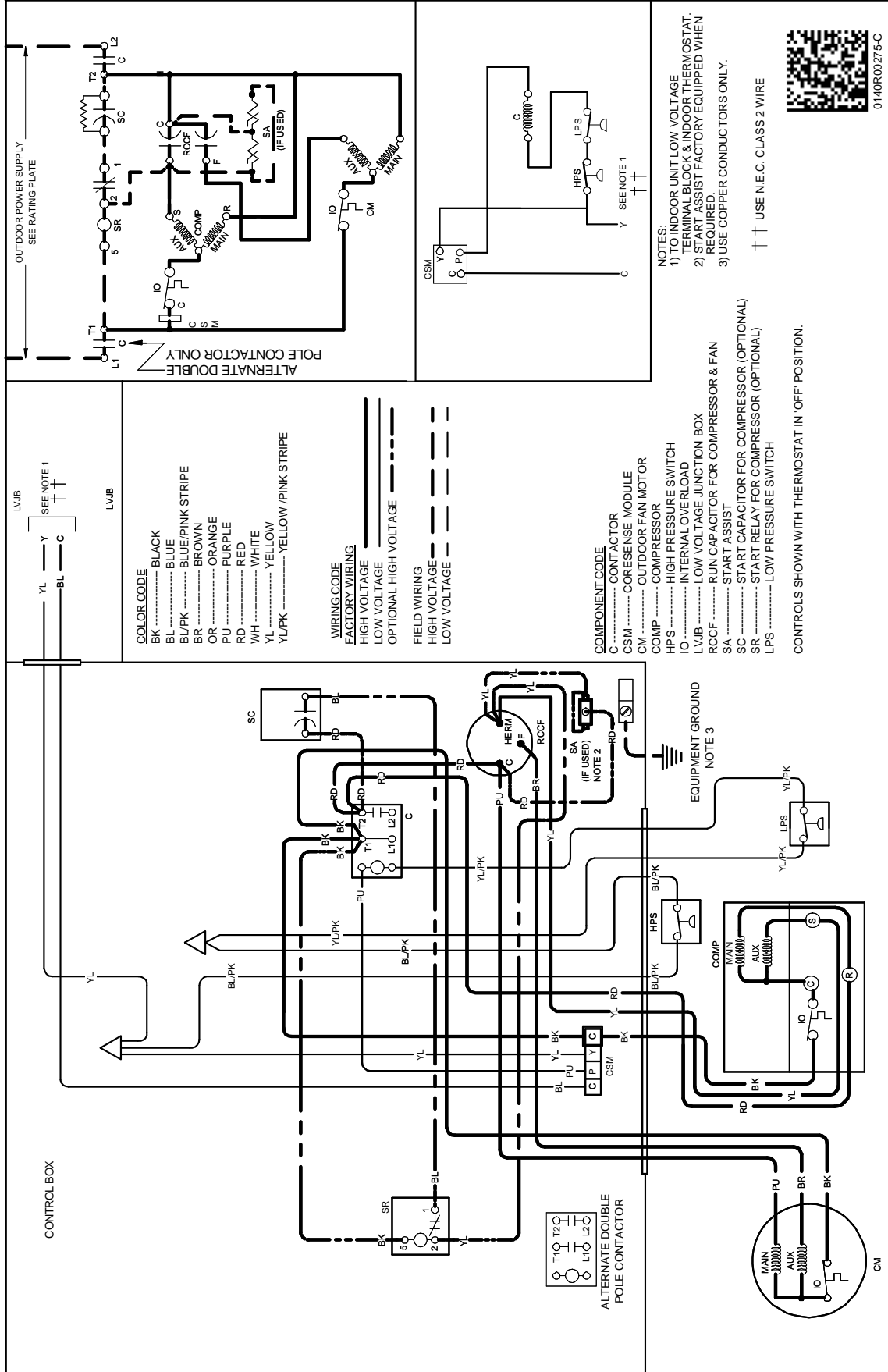

Wiring is subject to change. Always refer to the wiring diagram on the unit for the most up-to-date wiring.

**WARNING**  
**HIGH VOLTAGE!**  
 DISCONNECT ALL POWER BEFORE SERVICING OR INSTALLING THIS UNIT. MULTIPLE POWER SOURCES MAY BE PRESENT. FAILURE TO DO SO MAY CAUSE PROPERTY DAMAGE, PERSONAL INJURY OR DEATH.

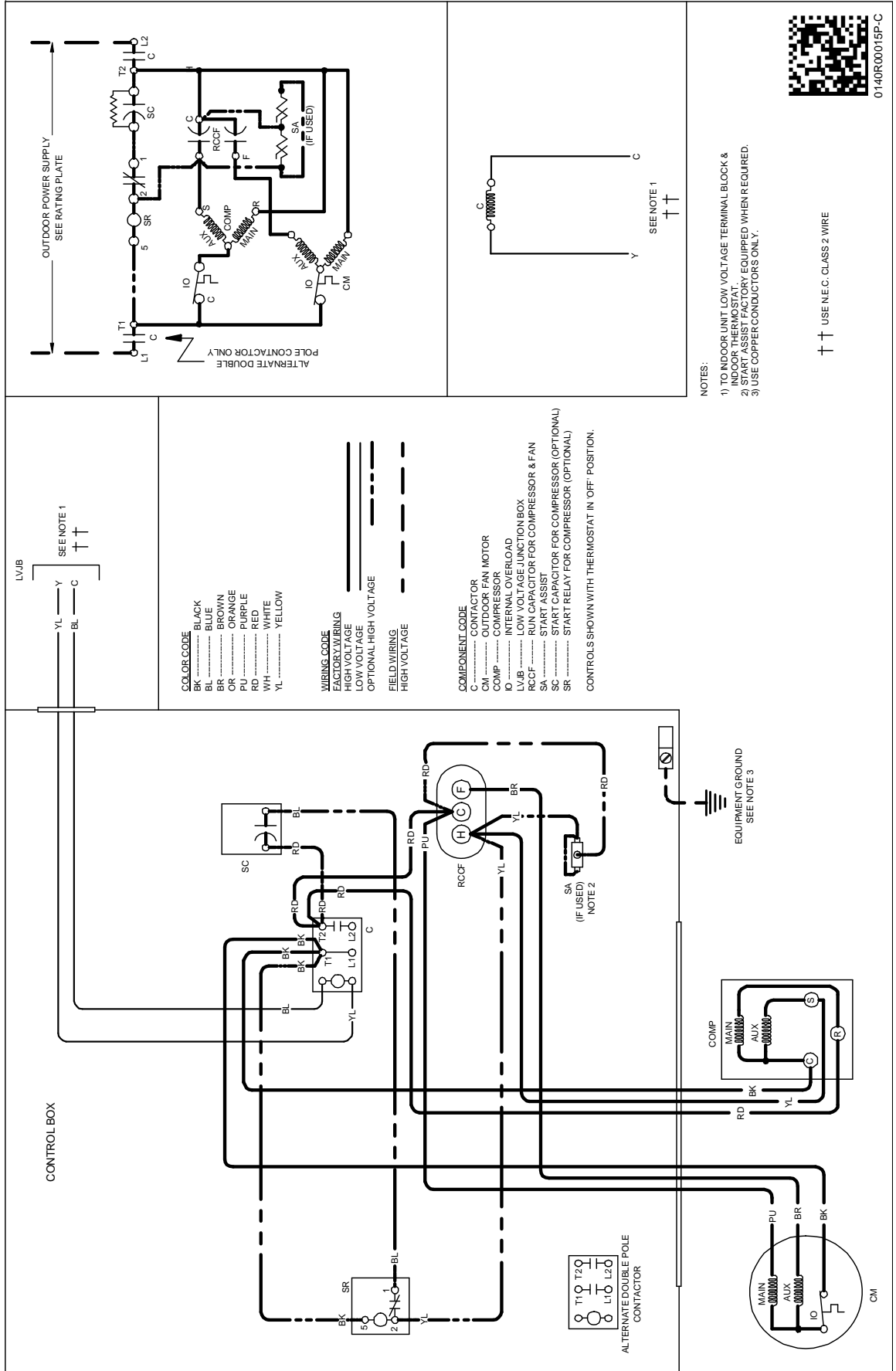

0140R0001SP-C

Wiring is subject to change. Always refer to the wiring diagram on the unit for the most up-to-date wiring.











**WARNING**  
HIGH VOLTAGE!  
DISCONNECT ALL POWER BEFORE SERVICING OR INSTALLING THIS UNIT. MULTIPLE POWER SOURCES MAY BE PRESENT. FAILURE TO DO SO MAY CAUSE PROPERTY DAMAGE, PERSONAL INJURY OR DEATH.

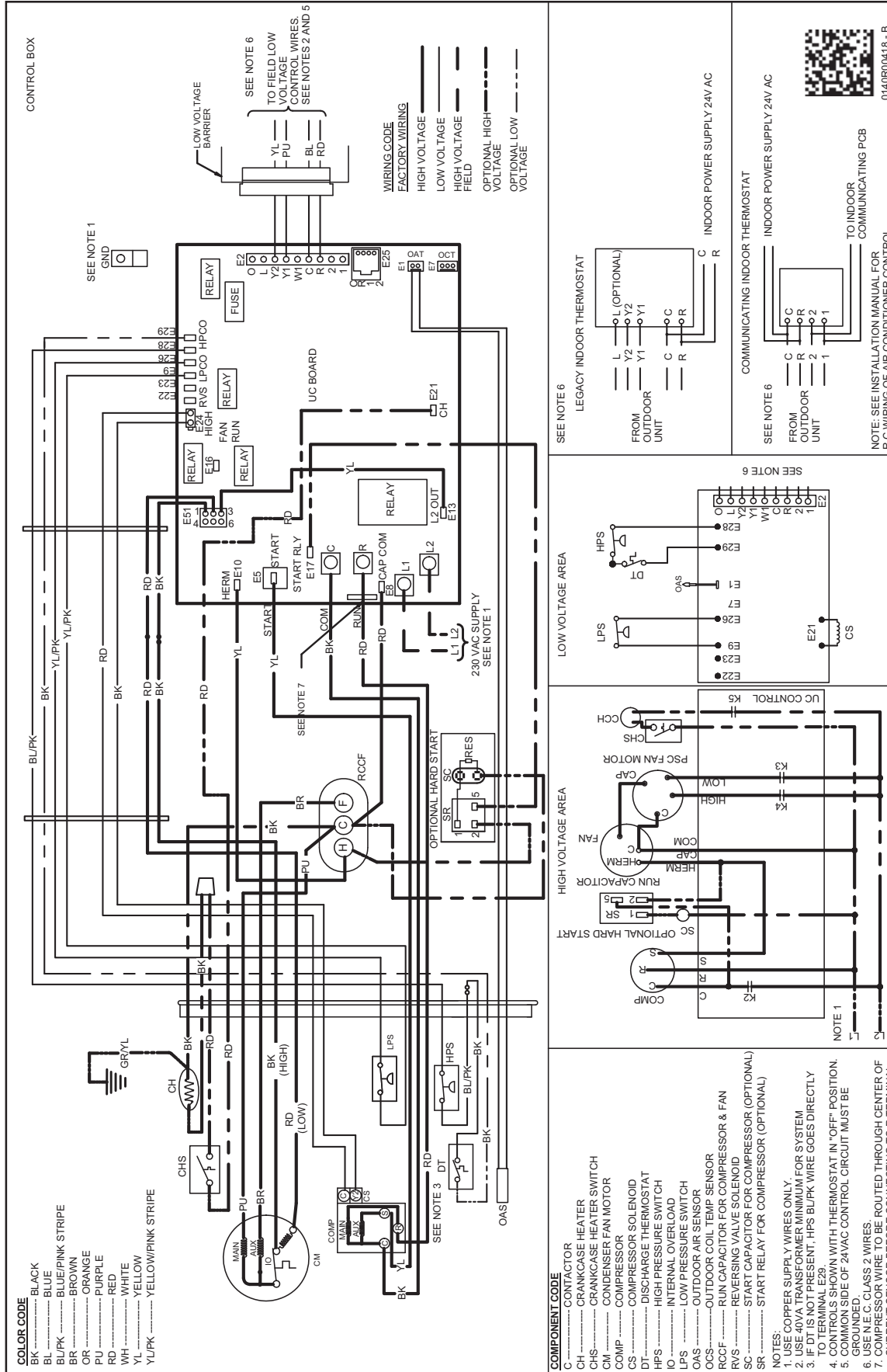

Wiring is subject to change. Always refer to the wiring diagram on the unit for the most up-to-date wiring.







**WARNING**  
**HIGH VOLTAGE!**  
 DISCONNECT ALL POWER BEFORE SERVICING OR INSTALLING THIS UNIT. MULTIPLE POWER SOURCES MAY BE PRESENT. FAILURE TO DO SO MAY CAUSE PROPERTY DAMAGE, PERSONAL INJURY OR DEATH.

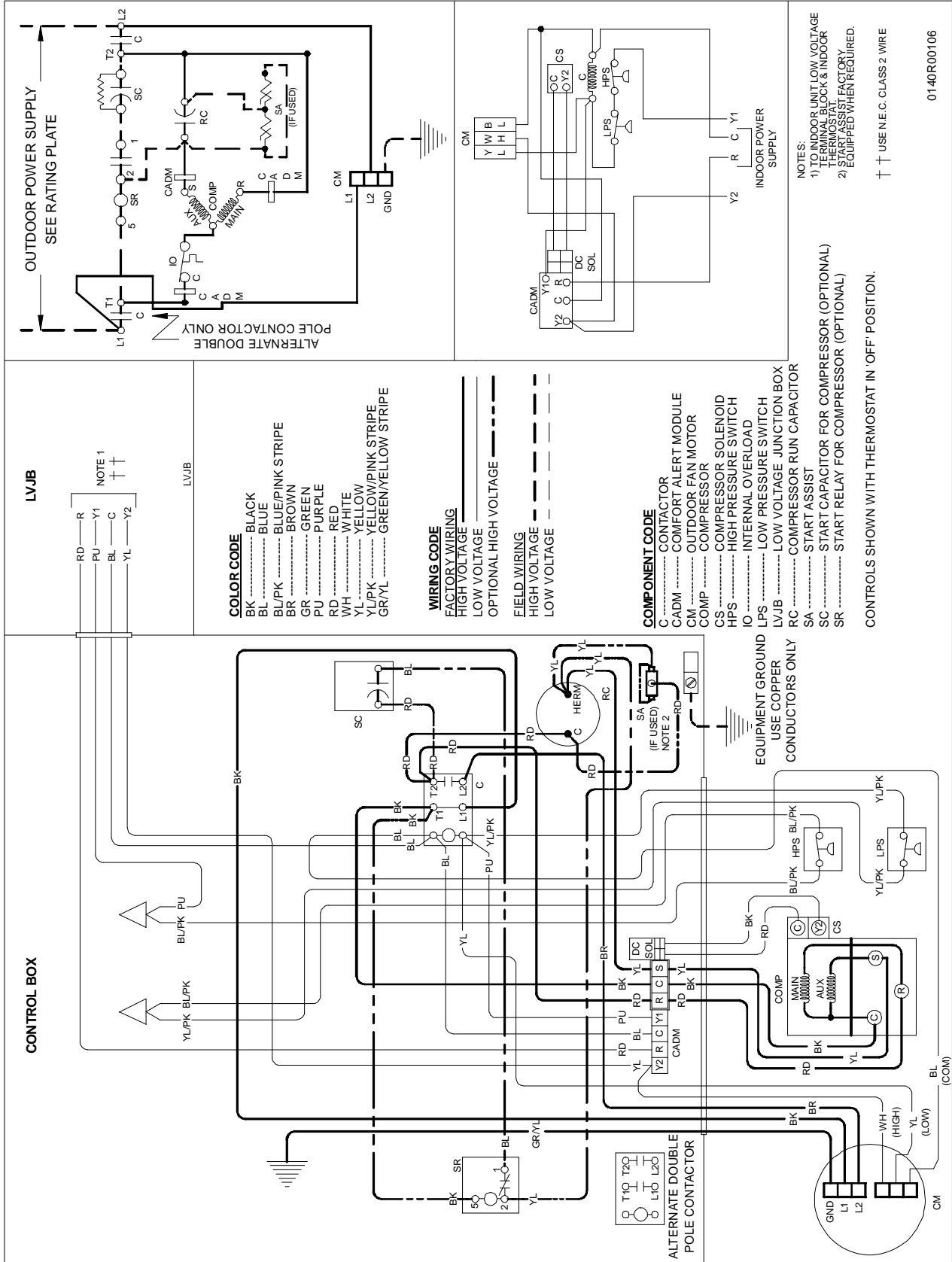

Wiring is subject to change. Always refer to the wiring diagram on the unit for the most up-to-date wiring.





**WARNING**  
**HIGH VOLTAGE!**  
 DISCONNECT ALL POWER BEFORE SERVICING OR INSTALLING THIS UNIT. MULTIPLE POWER SOURCES MAY BE PRESENT. FAILURE TO DO SO MAY CAUSE PROPERTY DAMAGE, PERSONAL INJURY OR DEATH.

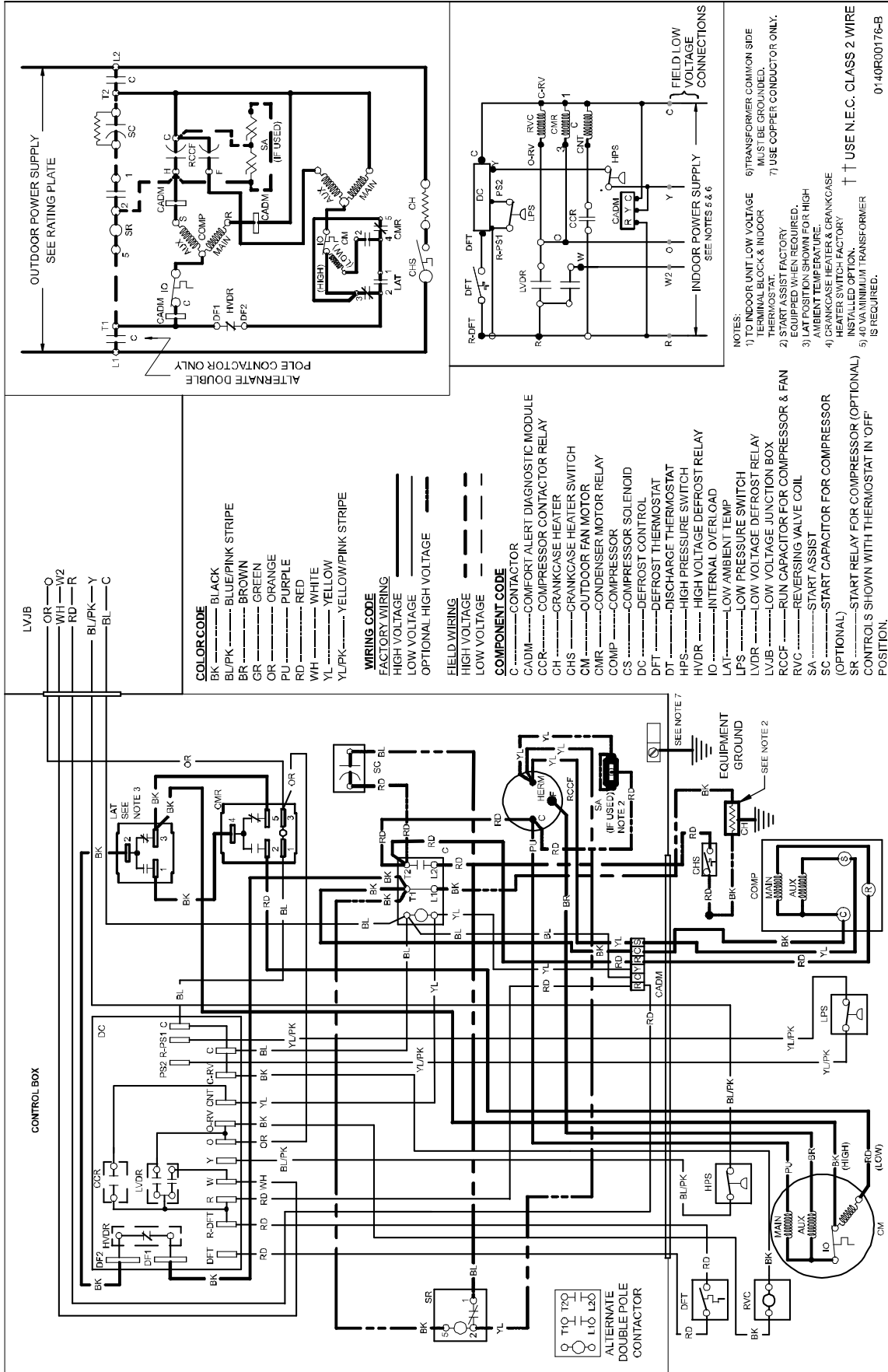

Wiring is subject to change. Always refer to the wiring diagram on the unit for the most up-to-date wiring.



**WARNING**  
**HIGH VOLTAGE!**  
 DISCONNECT ALL POWER BEFORE SERVICING OR INSTALLING THIS UNIT. MULTIPLE POWER SOURCES MAY BE PRESENT. FAILURE TO DO SO MAY CAUSE PROPERTY DAMAGE, PERSONAL INJURY OR DEATH.

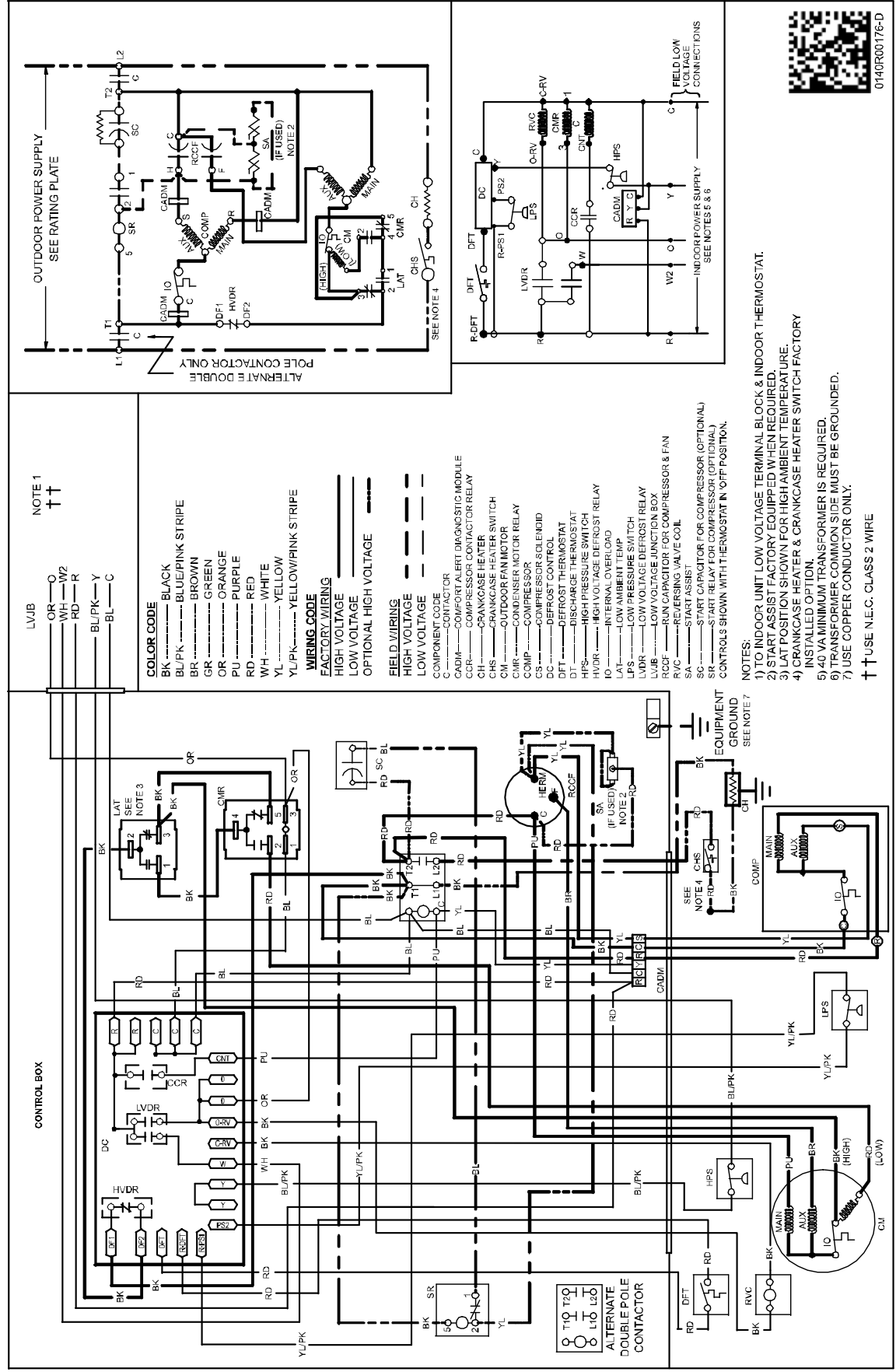

0140R00176-D

Wiring is subject to change. Always refer to the wiring diagram on the unit for the most up-to-date wiring.



**WARNING**  
**HIGH VOLTAGE!**  
 DISCONNECT ALL POWER BEFORE SERVICING OR INSTALLING THIS UNIT. MULTIPLE POWER SOURCES MAY BE PRESENT. FAILURE TO DO SO MAY CAUSE PROPERTY DAMAGE, PERSONAL INJURY OR DEATH.

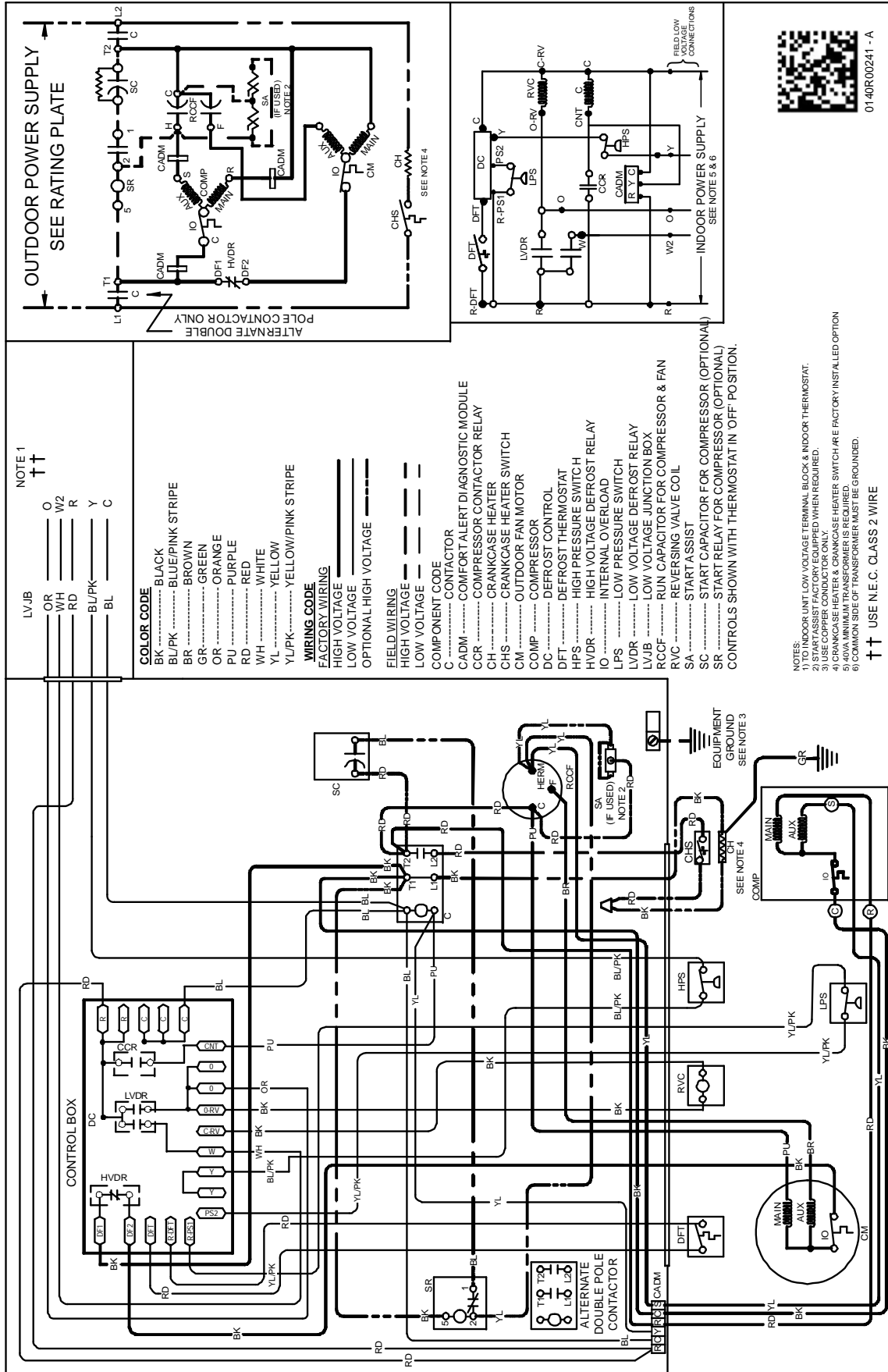

0140R00241 - A

Wiring is subject to change. Always refer to the wiring diagram on the unit for the most up-to-date wiring.



# WIRING DIAGRAMS

ASZ140[18, 30-36]1AA-AF  
ASZ14030241AA-AG, [042-060]1AA-AE



**WARNING**  
HIGH VOLTAGE!  
DISCONNECT ALL POWER BEFORE SERVICING OR INSTALLING THIS UNIT. MULTIPLE POWER SOURCES MAY BE PRESENT. FAILURE TO DO SO MAY CAUSE PROPERTY DAMAGE, PERSONAL INJURY OR DEATH.

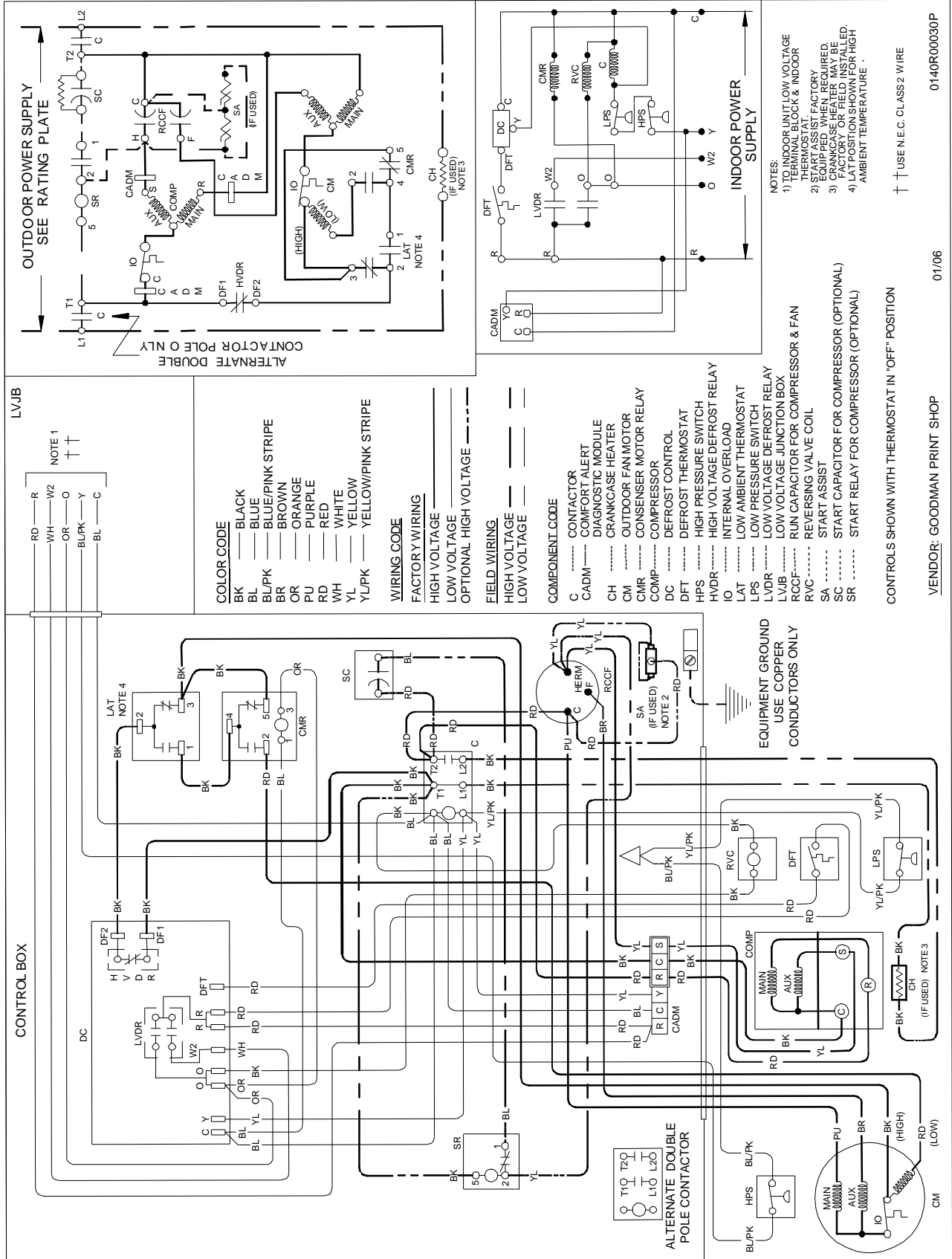



# WIRING DIAGRAMS

ASZ140[18, 30, 36]1AG/AH  
ASZ140241AH; [42, 48, 60]1AF/AG; ASZ140361B\*



**WARNING**  
HIGH VOLTAGE!  
DISCONNECT ALL POWER BEFORE SERVICING OR INSTALLING THIS UNIT. MULTIPLE POWER SOURCES MAY BE PRESENT. FAILURE TO DO SO MAY CAUSE PROPERTY DAMAGE, PERSONAL INJURY OR DEATH.

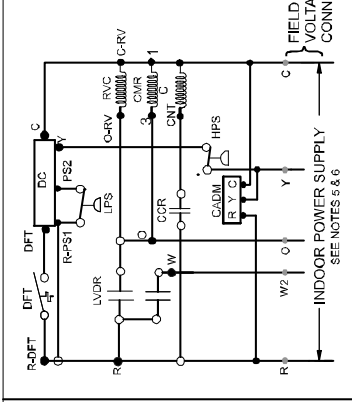
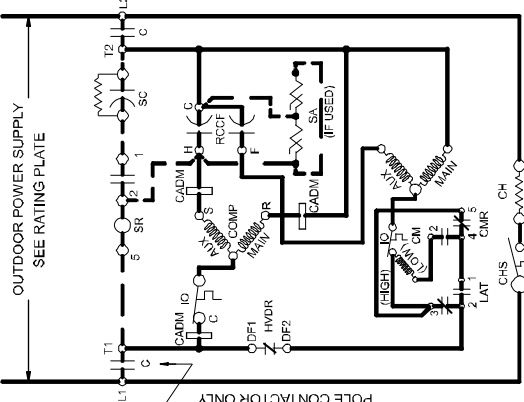
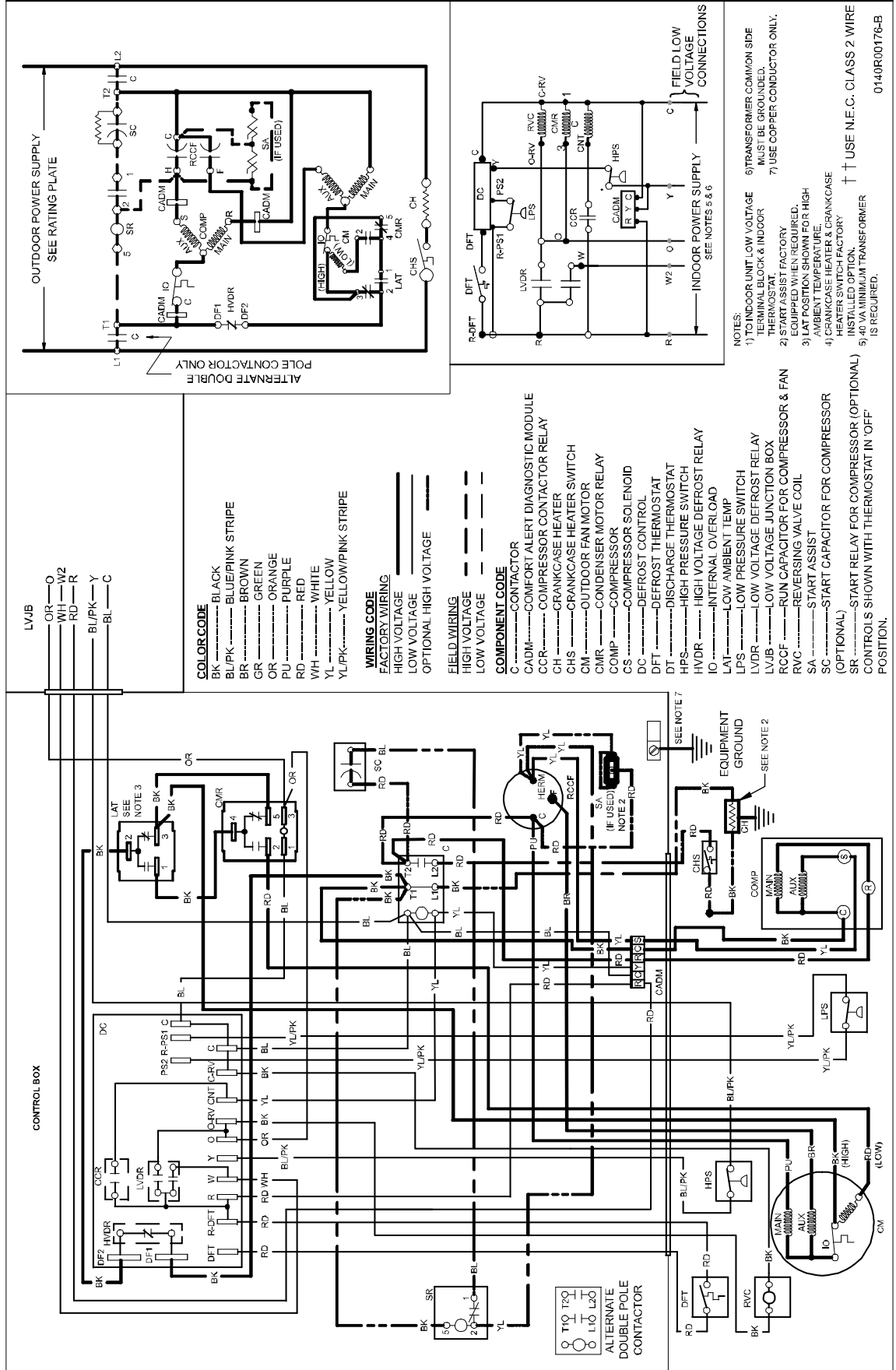

**COLOR CODE**

|       |                    |
|-------|--------------------|
| BK    | BLACK              |
| BL/PK | BLUE/PINK STRIPE   |
| BR    | BROWN              |
| GR    | GREEN              |
| OR    | ORANGE             |
| PU    | PURPLE             |
| RD    | RED                |
| WH    | WHITE              |
| YL    | YELLOW             |
| YL/PK | YELLOW/PINK STRIPE |

**WIRING CODE**

|     |                       |
|-----|-----------------------|
| --- | HIGH VOLTAGE          |
| --- | LOW VOLTAGE           |
| --- | OPTIONAL HIGH VOLTAGE |

**FIELD WIRING**

|     |              |
|-----|--------------|
| --- | HIGH VOLTAGE |
| --- | LOW VOLTAGE  |

**COMPONENT CODE**

|      |   |
|------|---|
| C    | CONTACTOR                                 |
| CADM | COMFORT ALERT DIAGNOSTIC MODULE           |
| CCR  | COMPRESSOR CONTACTOR RELAY                |
| CH   | CRANKCASE HEATER                          |
| CHS  | CRANKCASE HEATER SWITCH                   |
| CMR  | CONDENSER MOTOR RELAY                     |
| COMP | COMPRESSOR                                |
| CS   | COMPRESSOR SOLENOID                       |
| DC   | DEFROST CONTROL                           |
| DFT  | DEFROST THERMOSTAT                        |
| DT   | DISCHARGE THERMOSTAT                      |
| HPS  | HIGH VOLTAGE DEFROST RELAY                |
| HVDR | HIGH VOLTAGE DEFROST RELAY                |
| IO   | INTERNAL OVERLOAD                         |
| LAT  | LOW AMBIENT TEMP                          |
| LPS  | LOW VOLTAGE DEFROST RELAY                 |
| LVJB | LOW VOLTAGE JUNCTION BOX                  |
| RCCF | RUN CAPACITOR FOR COMPRESSOR & FAN        |
| RVC  | REVERSING VALVE COIL                      |
| SA   | START ASSIST                              |
| SC   | START CAPACITOR FOR COMPRESSOR (OPTIONAL) |
| SR   | START RELAY FOR COMPRESSOR (OPTIONAL)     |

CONTROLS SHOWN WITH THERMOSTAT IN 'OFF' POSITION.

- NOTES:
- 1) TO INDOOR UNIT LOW VOLTAGE TERMINAL BLOCK & INDOOR THERMOSTAT FACTORY EQUIPPED WHEN REQUIRED.
  - 2) LAT POSITION SHOWN FOR HIGH AMBIENT TEMPERATURE.
  - 3) CRANKCASE HEATER & CRANKCASE HEATER SWITCH FACTORY INSTALLED OPTION.
  - 4) 40 VA MINIMUM TRANSFORMER IS REQUIRED.
  - 5) TO INDOOR UNIT LOW VOLTAGE TERMINAL BLOCK & INDOOR THERMOSTAT FACTORY EQUIPPED WHEN REQUIRED.
  - 6) USE COPPER CONDUCTOR ONLY.
  - 7) USE N.E.C. CLASS 2 WIRE IS REQUIRED.

0140R00176-B

Wiring is subject to change. Always refer to the wiring diagram on the unit for the most up-to-date wiring.





# WIRING DIAGRAMS

ASZ140381AA; ASZ140[18, 30]1AK; ASZ140241AL;  
 ASZ140301AK; ASZ140421AJ  
 ASZ140[18-30]1B\*



**WARNING**  
 HIGH VOLTAGE!  
 DISCONNECT ALL POWER BEFORE SERVICING OR INSTALLING THIS UNIT. MULTIPLE POWER SOURCES MAY BE PRESENT. FAILURE TO DO SO MAY CAUSE PROPERTY DAMAGE, PERSONAL INJURY OR DEATH.

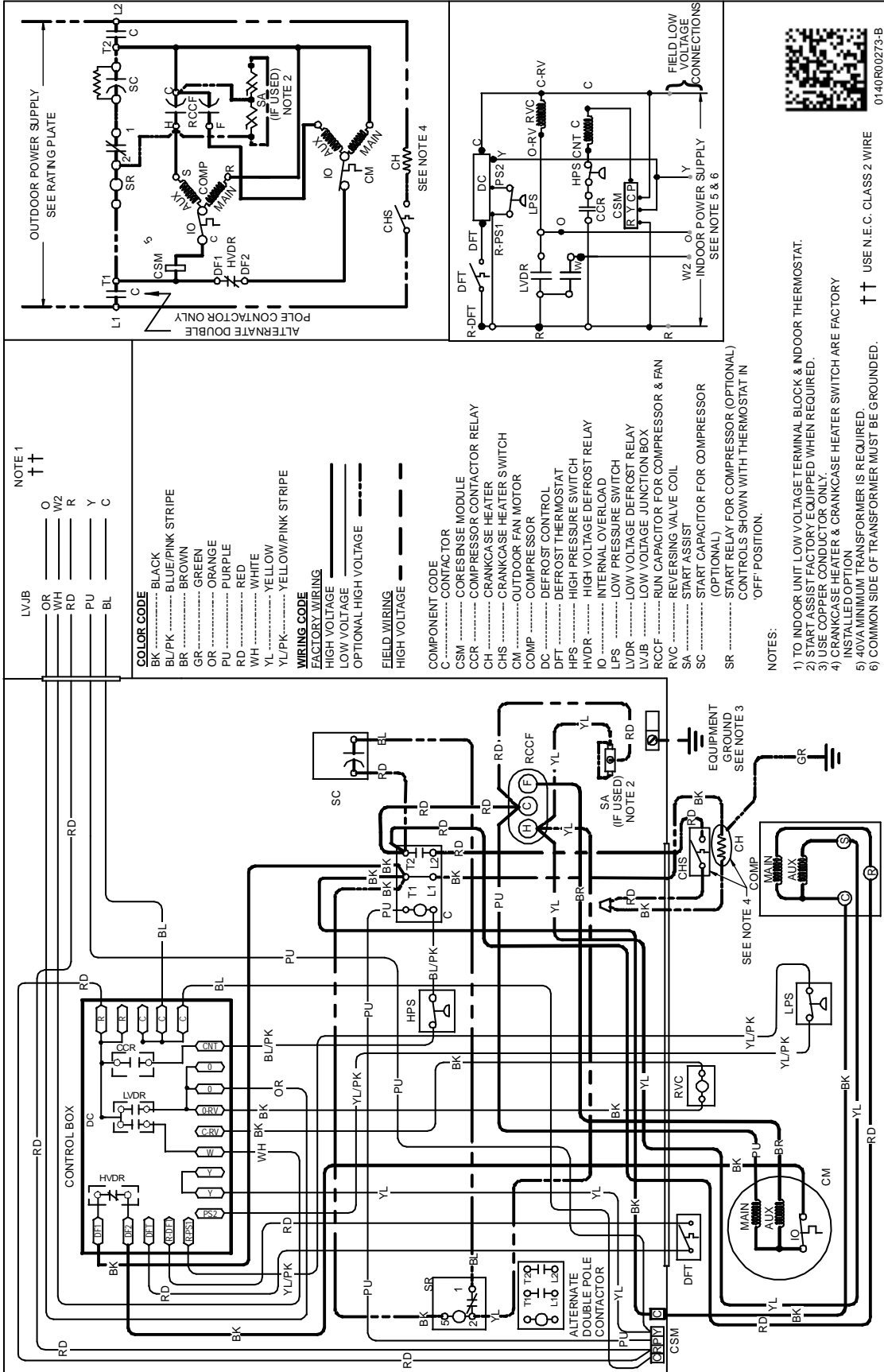

NOTE 1  
 ††

|      |    |    |
|------|----|----|
| LVJB | OR | O  |
| RD   | WH | W2 |
| RD   | R  | Y  |
| PU   | Y  | C  |
| BL   | BL |    |

**COLOR CODE**

- BK ..... BLACK
- BL/PK ..... BLUE/PINK STRIPE
- BR ..... BROWN
- GR ..... GREEN
- OR ..... ORANGE
- PU ..... PURPLE
- RD ..... RED
- WH ..... WHITE
- YL ..... YELLOW
- YL/PK ..... YELLOW/PINK STRIPE

**WIRING CODE**

**FACTORY WIRING**

- HIGH VOLTAGE
- LOW VOLTAGE
- OPTIONAL HIGH VOLTAGE

**FIELD WIRING**

- HIGH VOLTAGE
- LOW VOLTAGE

**COMPONENT CODE**

- C ..... CONTACTOR
- CCM ..... CORENSE MODULE
- CCR ..... COMPRESSOR CONTACTOR RELAY
- CH ..... CRANKCASE HEATER
- CHS ..... CRANKCASE HEATER SWITCH
- CM ..... OUTDOOR FAN MOTOR
- COMP ..... COMPRESSOR
- DC ..... DEFROST CONTROL
- DFT ..... DEFROST THERMOSTAT
- HPS ..... HIGH PRESSURE SWITCH
- HVDR ..... HIGH VOLTAGE DEFROST RELAY
- IO ..... INTERNAL OVERLOAD
- LPS ..... LOW PRESSURE SWITCH
- LVD ..... LOW VOLTAGE DEFROST RELAY
- LVJB ..... LOW VOLTAGE JUNCTION BOX
- RCCF ..... RUN CAPACITOR FOR COMPRESSOR & FAN
- RVC ..... REVERSING VALVE COIL
- SA ..... START ASSIST
- SC ..... START CAPACITOR FOR COMPRESSOR (OPTIONAL)
- SR ..... START RELAY FOR COMPRESSOR (OPTIONAL) CONTROLS SHOWN WITH THERMOSTAT IN 'OFF' POSITION.

- NOTES:**
- 1) TO INDOOR UNIT LOW VOLTAGE TERMINAL BLOCK & INDOOR THERMOSTAT.
  - 2) START ASSIST FACTORY EQUIPPED WHEN REQUIRED.
  - 3) USE COPPER CONDUCTOR ONLY.
  - 4) CRANKCASE HEATER & CRANKCASE HEATER SWITCH ARE FACTORY INSTALLED OPTION.
  - 5) 40VA MINIMUM TRANSFORMER IS REQUIRED.
  - 6) COMMON SIDE OF TRANSFORMER MUST BE GROUNDED.

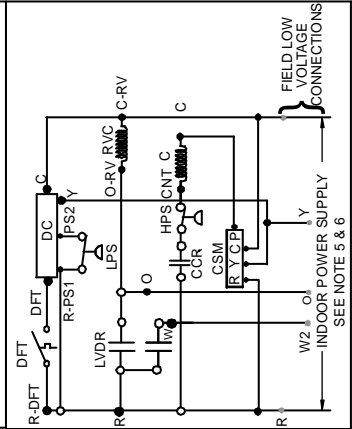
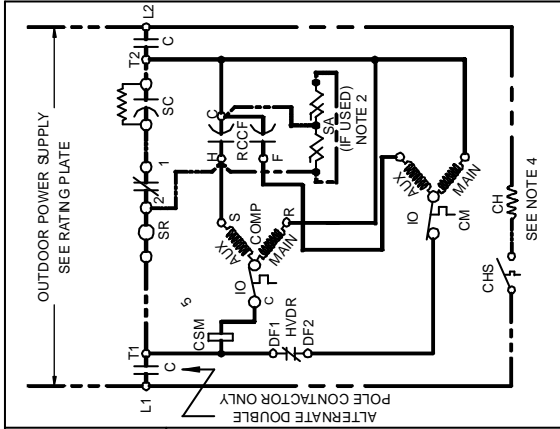

0140R00273-B

Wiring is subject to change. Always refer to the wiring diagram on the unit for the most up-to-date wiring.





**WARNING**  
HIGH VOLTAGE!  
DISCONNECT ALL POWER BEFORE SERVICING OR INSTALLING THIS UNIT. MULTIPLE POWER SOURCES MAY BE PRESENT. FAILURE TO DO SO MAY CAUSE PROPERTY DAMAGE, PERSONAL INJURY OR DEATH.

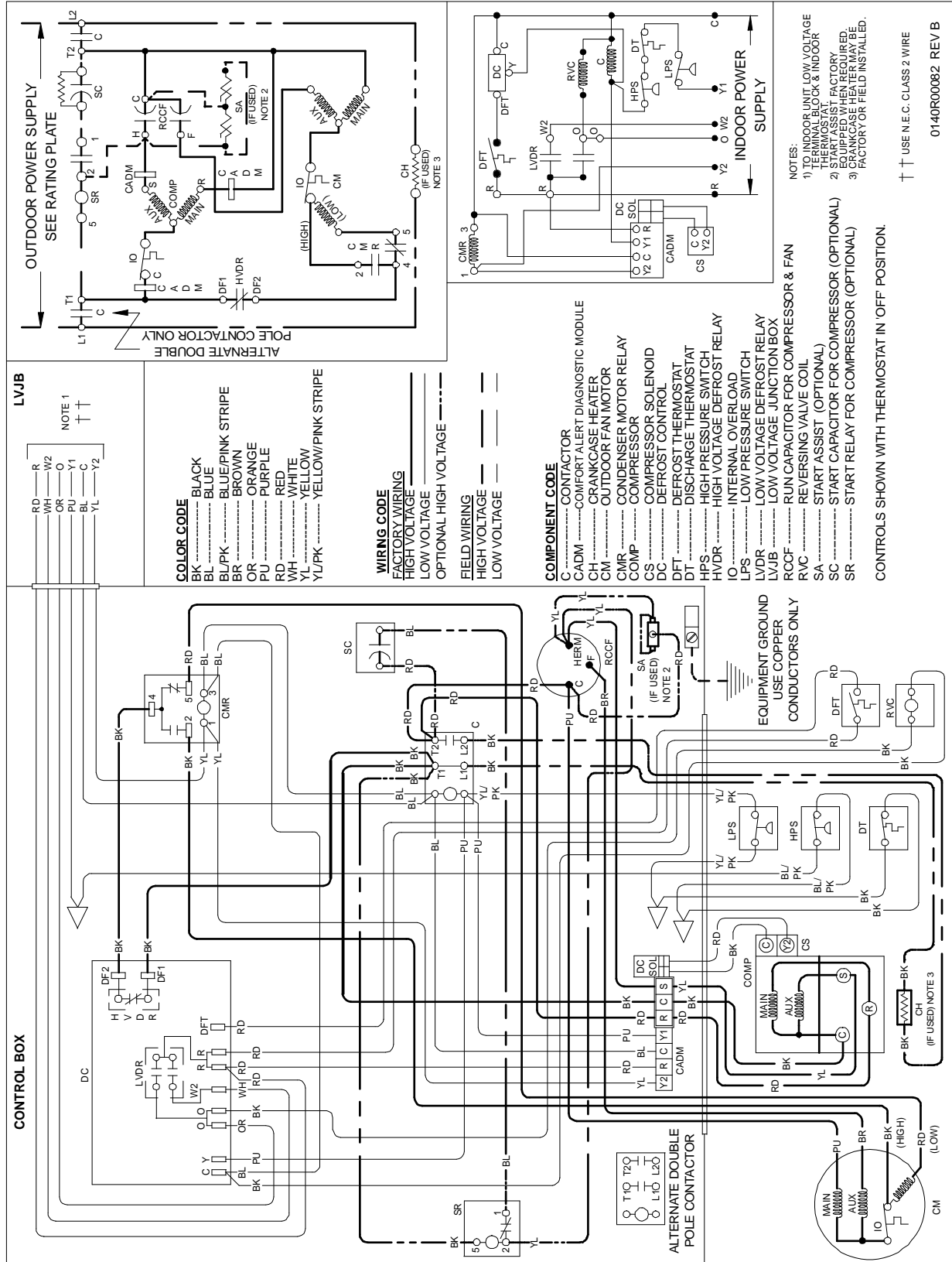

Wiring is subject to change. Always refer to the wiring diagram on the unit for the most up-to-date wiring.





**WARNING**  
HIGH VOLTAGE!  
DISCONNECT ALL POWER BEFORE SERVICING OR INSTALLING THIS UNIT. MULTIPLE POWER SOURCES MAY BE PRESENT. FAILURE TO DO SO MAY CAUSE PROPERTY DAMAGE, PERSONAL INJURY OR DEATH.

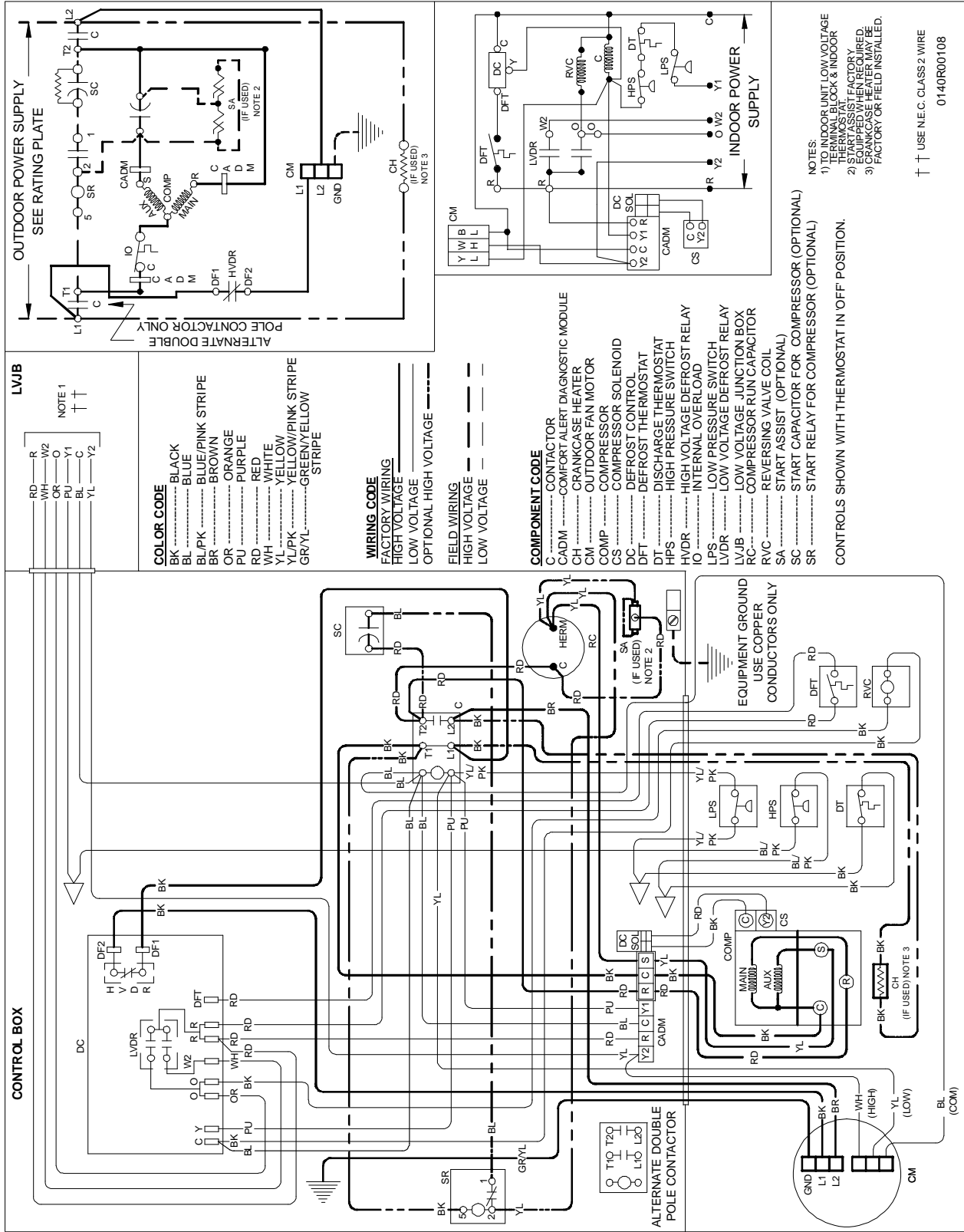

Wiring is subject to change. Always refer to the wiring diagram on the unit for the most up-to-date wiring.



**WARNING**  
 HIGH VOLTAGE!  
 DISCONNECT ALL POWER BEFORE SERVICING OR INSTALLING THIS UNIT. MULTIPLE POWER SOURCES MAY BE PRESENT. FAILURE TO DO SO MAY CAUSE PROPERTY DAMAGE, PERSONAL INJURY OR DEATH.

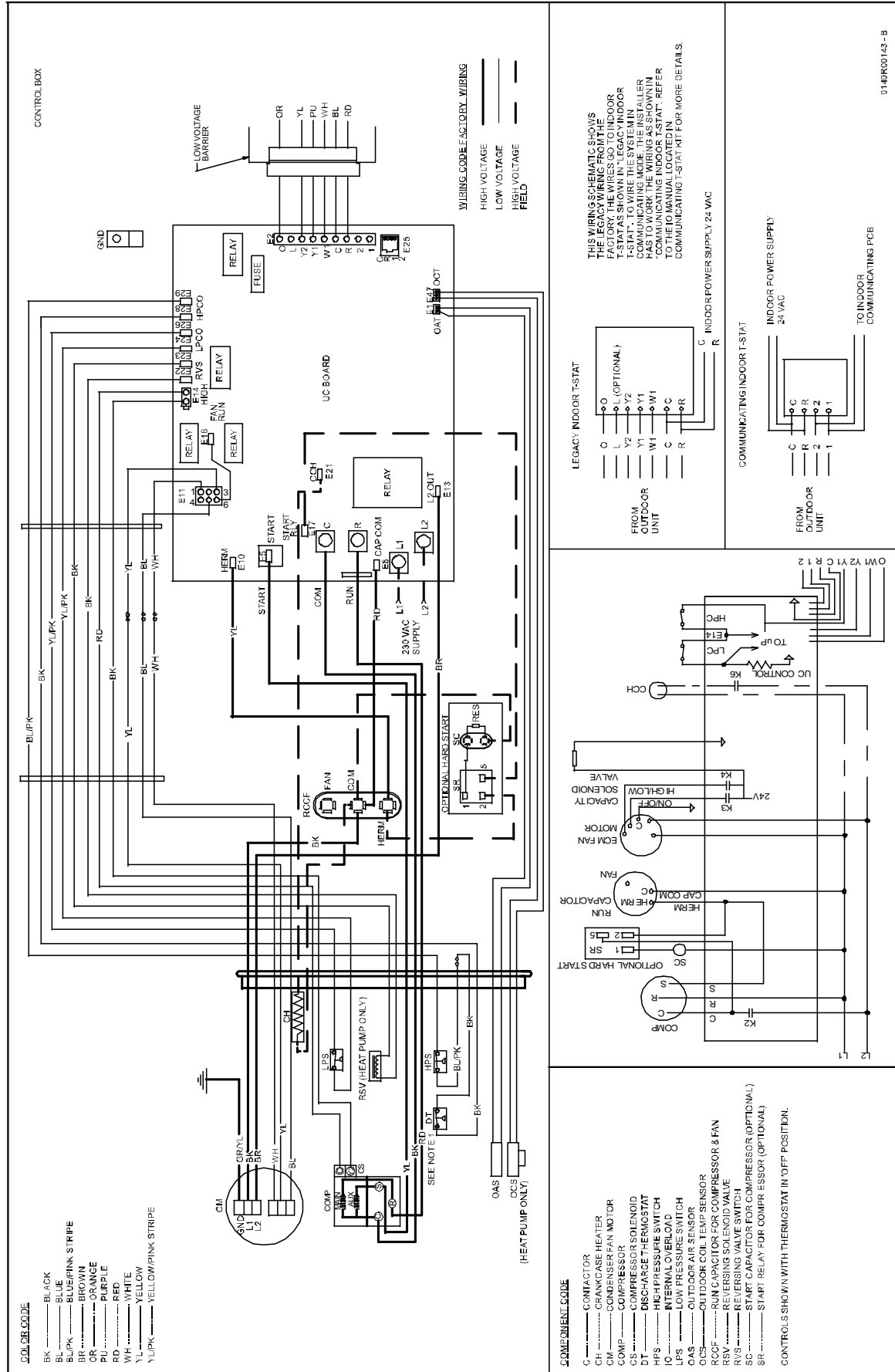

Wiring is subject to change. Always refer to the wiring diagram on the unit for the most up-to-date wiring.



**WARNING**  
HIGH VOLTAGE!  
DISCONNECT ALL POWER BEFORE SERVICING OR INSTALLING THIS UNIT. MULTIPLE POWER SOURCES MAY BE PRESENT. FAILURE TO DO SO MAY CAUSE PROPERTY DAMAGE, PERSONAL INJURY OR DEATH.

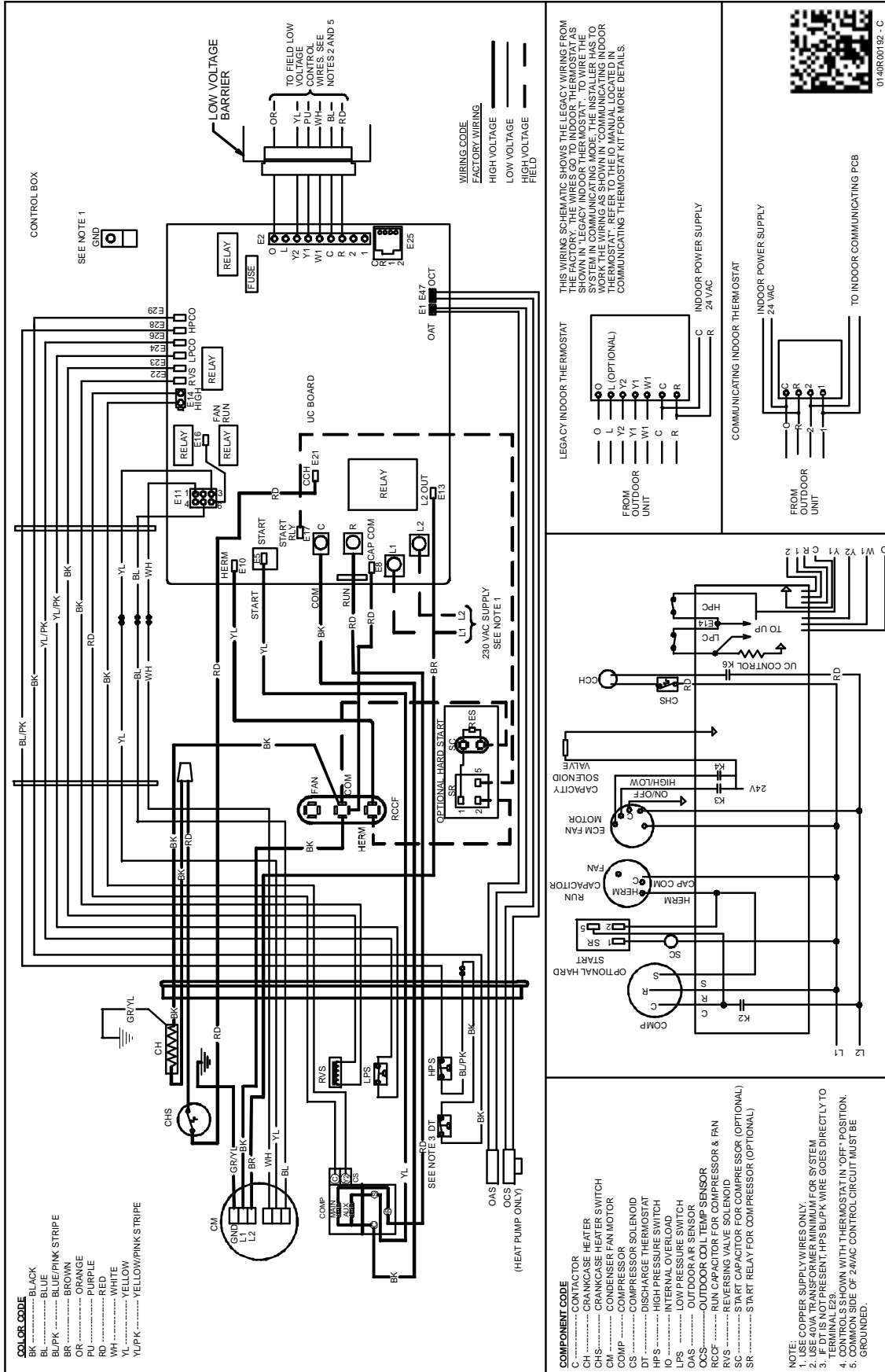

01-GR00192 - C

Wiring is subject to change. Always refer to the wiring diagram on the unit for the most up-to-date wiring.



**WARNING**  
 HIGH VOLTAGE!  
 DISCONNECT ALL POWER BEFORE SERVICING OR INSTALLING THIS UNIT. MULTIPLE POWER SOURCES MAY BE PRESENT. FAILURE TO DO SO MAY CAUSE PROPERTY DAMAGE, PERSONAL INJURY OR DEATH.

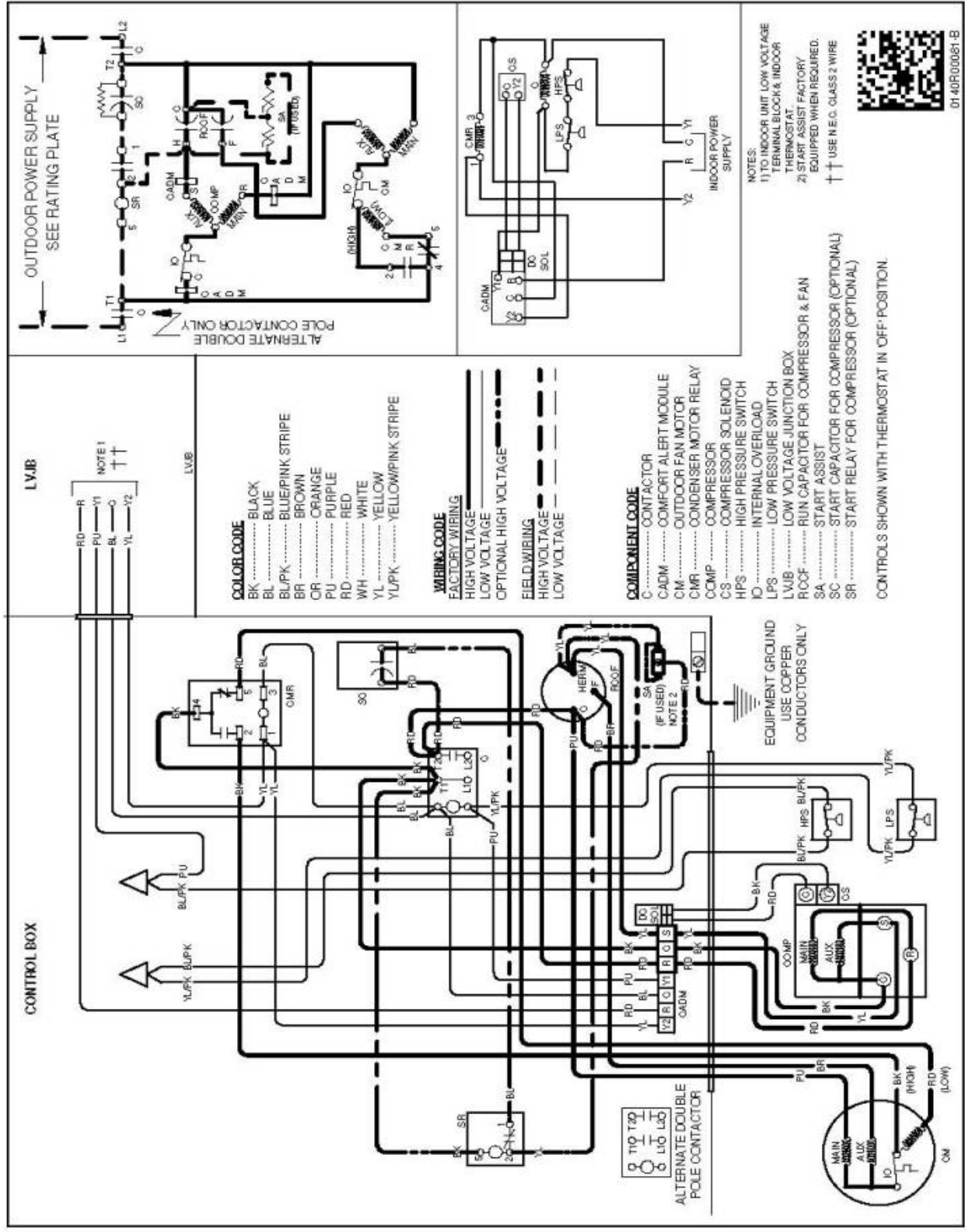

01-40R00081-B

Wiring is subject to change. Always refer to the wiring diagram on the unit for the most up-to-date wiring.



**WARNING**

**HIGH VOLTAGE!**  
DISCONNECT ALL POWER BEFORE SERVICING OR INSTALLING THIS UNIT. MULTIPLE POWER SOURCES MAY BE PRESENT. FAILURE TO DO SO MAY CAUSE PROPERTY DAMAGE, PERSONAL INJURY OR DEATH.

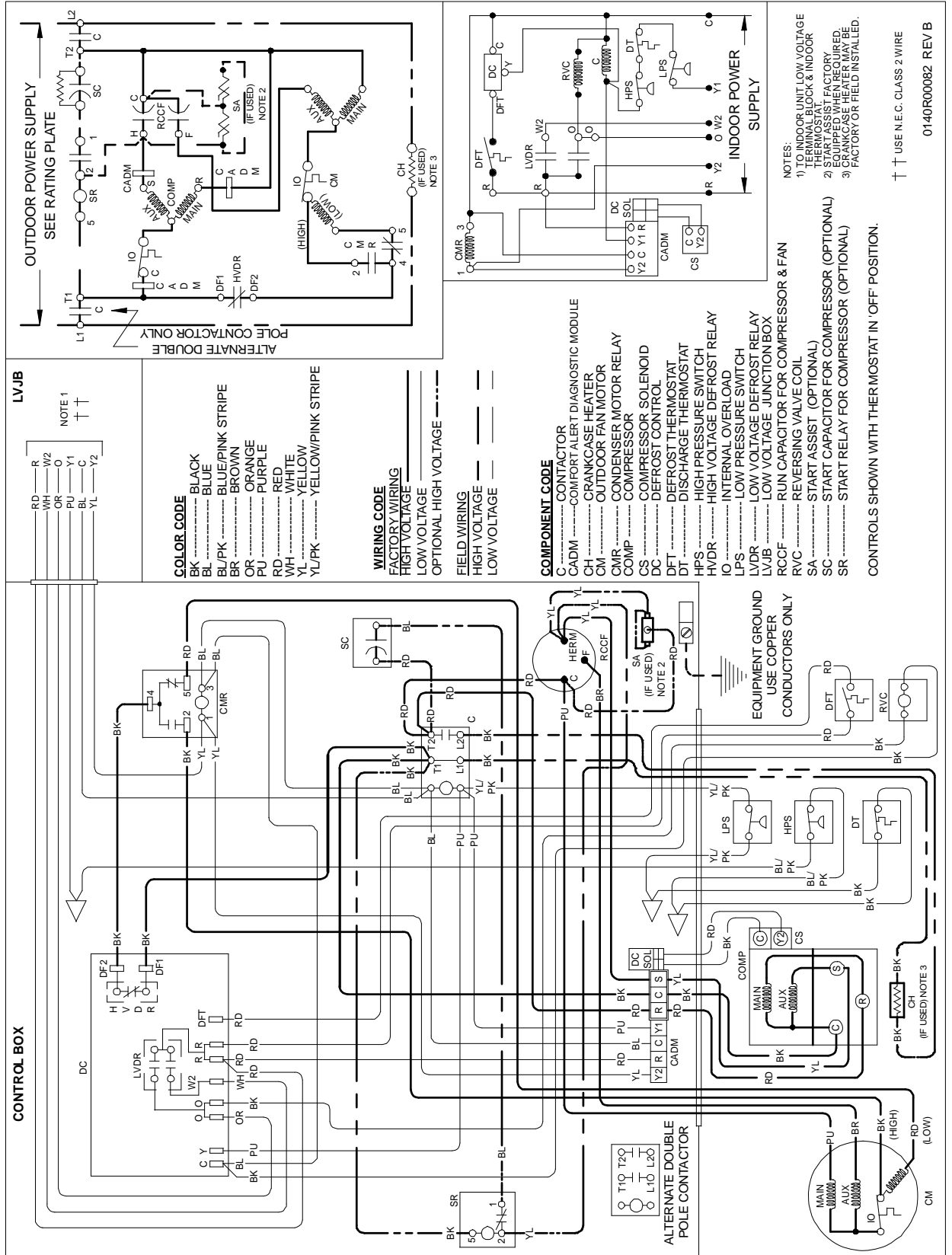

LVJB

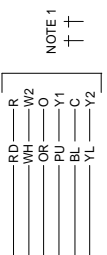

NOTE 1  
++

- COLOR CODE**
- BK ..... BLACK
  - BL ..... BLUE
  - BL/PK ..... BLUE/PINK STRIPE
  - BK ..... BROWN
  - OR ..... ORANGE
  - PU ..... PURPLE
  - RD ..... RED
  - WH ..... WHITE
  - YL ..... YELLOW
  - YL/PK ..... YELLOW/PINK STRIPE

- WIRING CODE**
- FACTORY WIRING
  - HIGH VOLTAGE
  - LOW VOLTAGE
  - OPTIONAL HIGH VOLTAGE
  - FIELD WIRING
  - HIGH VOLTAGE
  - LOW VOLTAGE

- COMPONENT CODE**
- C ..... CONTACTOR
  - CADM ..... COMFORT ALERT DIAGNOSTIC MODULE
  - CH ..... CRANKCASE HEATER
  - CM ..... OUTDOOR FAN MOTOR
  - CMR ..... CONDENSER MOTOR RELAY
  - COMP ..... COMPRESSOR
  - CS ..... COMPRESSOR SOLENOID
  - DC ..... DEFROST CONTROL
  - DFT ..... DEFROST THERMOSTAT
  - DT ..... DISCHARGE THERMOSTAT
  - HPS ..... HIGH PRESSURE SWITCH
  - HVDR ..... HIGH VOLTAGE DEFROST RELAY
  - IO ..... INTERNAL OVERLOAD
  - LPS ..... LOW PRESSURE SWITCH
  - LVDR ..... LOW VOLTAGE DEFROST RELAY
  - LVJB ..... LOW VOLTAGE JUNCTION BOX
  - RCCF ..... RUN CAPACITOR FOR COMPRESSOR & FAN
  - RVC ..... REVERSING VALVE COIL
  - SA ..... START ASSIST (OPTIONAL)
  - SC ..... START CAPACITOR FOR COMPRESSOR (OPTIONAL)
  - SR ..... START RELAY FOR COMPRESSOR (OPTIONAL)

CONTROLS SHOWN WITH THERMOSTAT IN 'OFF' POSITION.

- NOTES:
- 1) TO INDOOR UNIT LOW VOLTAGE TERMINALS, LOCK & INDOOR TERMINALS.
  - 2) START ASSIST FACTORY EQUIPPED WHEN HEATER IS FACTORY OR FIELD INSTALLED.
  - 3) CRANKCASE HEATER MAY BE FACTORY OR FIELD INSTALLED.

† USE N.E.C. CLASS 2 WIRE

0140R00082 REV B

Wiring is subject to change. Always refer to the wiring diagram on the unit for the most up-to-date wiring.



**WARNING**  
**HIGH VOLTAGE!**  
 DISCONNECT ALL POWER BEFORE SERVICING OR INSTALLING THIS UNIT. MULTIPLE POWER SOURCES MAY BE PRESENT. FAILURE TO DO SO MAY CAUSE PROPERTY DAMAGE, PERSONAL INJURY OR DEATH.

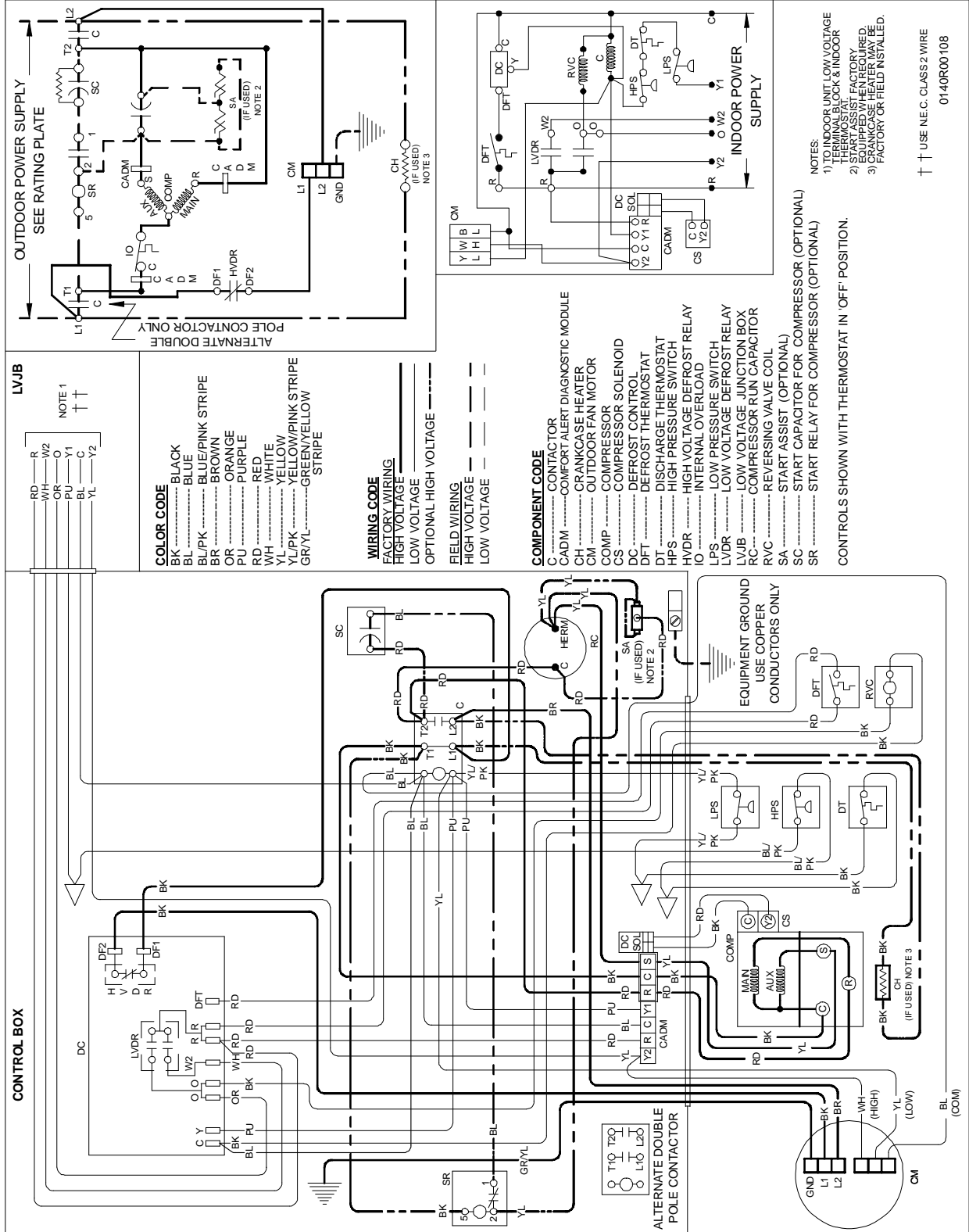

Wiring is subject to change. Always refer to the wiring diagram on the unit for the most up-to-date wiring.

**WARNING**

**HIGH VOLTAGE!**  
 DISCONNECT ALL POWER BEFORE SERVICING OR INSTALLING THIS UNIT. MULTIPLE POWER SOURCES MAY BE PRESENT. FAILURE TO DO SO MAY CAUSE PROPERTY DAMAGE, PERSONAL INJURY OR DEATH.

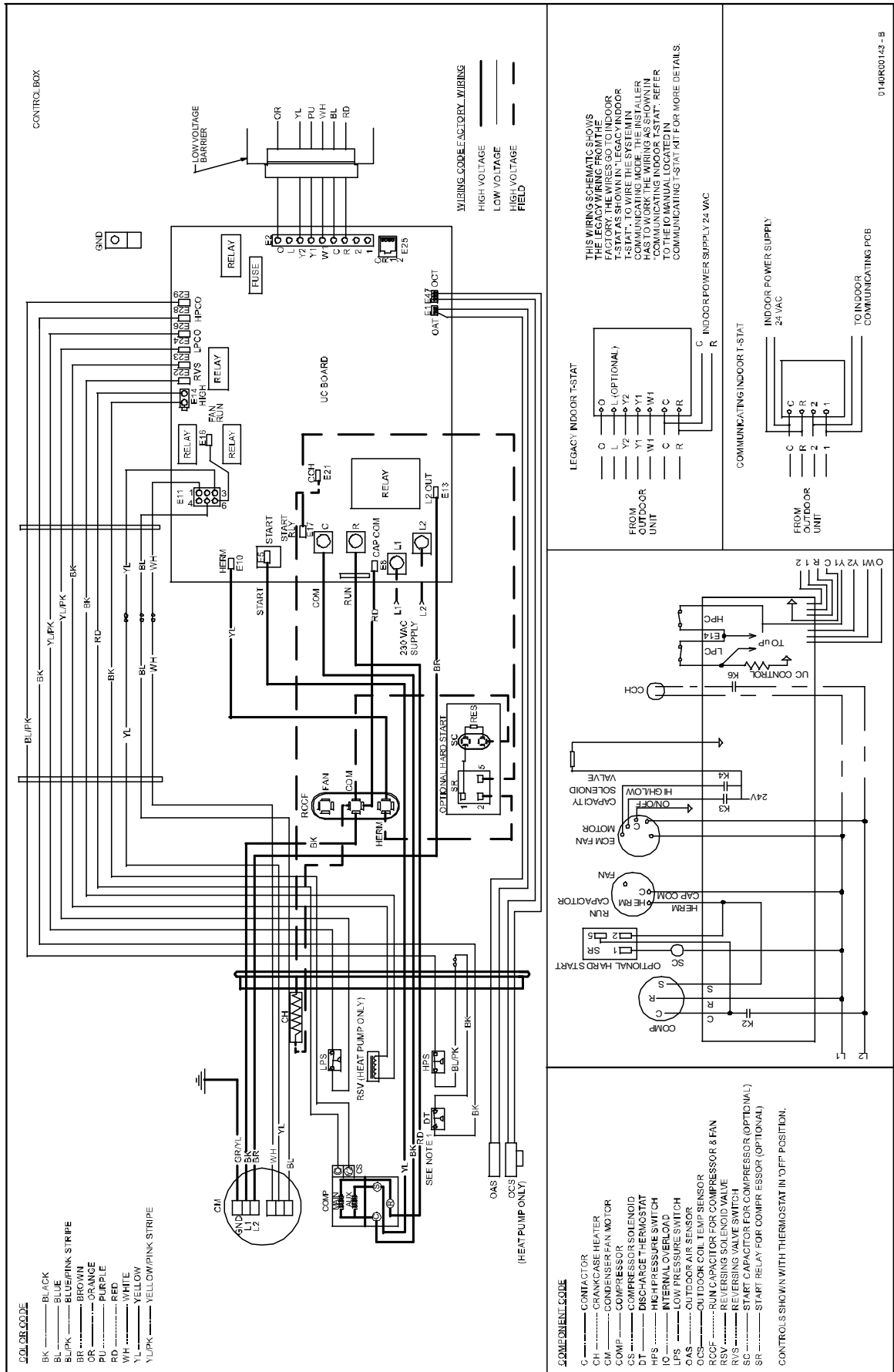

Wiring is subject to change. Always refer to the wiring diagram on the unit for the most up-to-date wiring.



**WARNING**  
HIGH VOLTAGE!  
DISCONNECT ALL POWER BEFORE SERVICING OR INSTALLING THIS UNIT. MULTIPLE POWER SOURCES MAY BE PRESENT. FAILURE TO DO SO MAY CAUSE PROPERTY DAMAGE, PERSONAL INJURY OR DEATH.

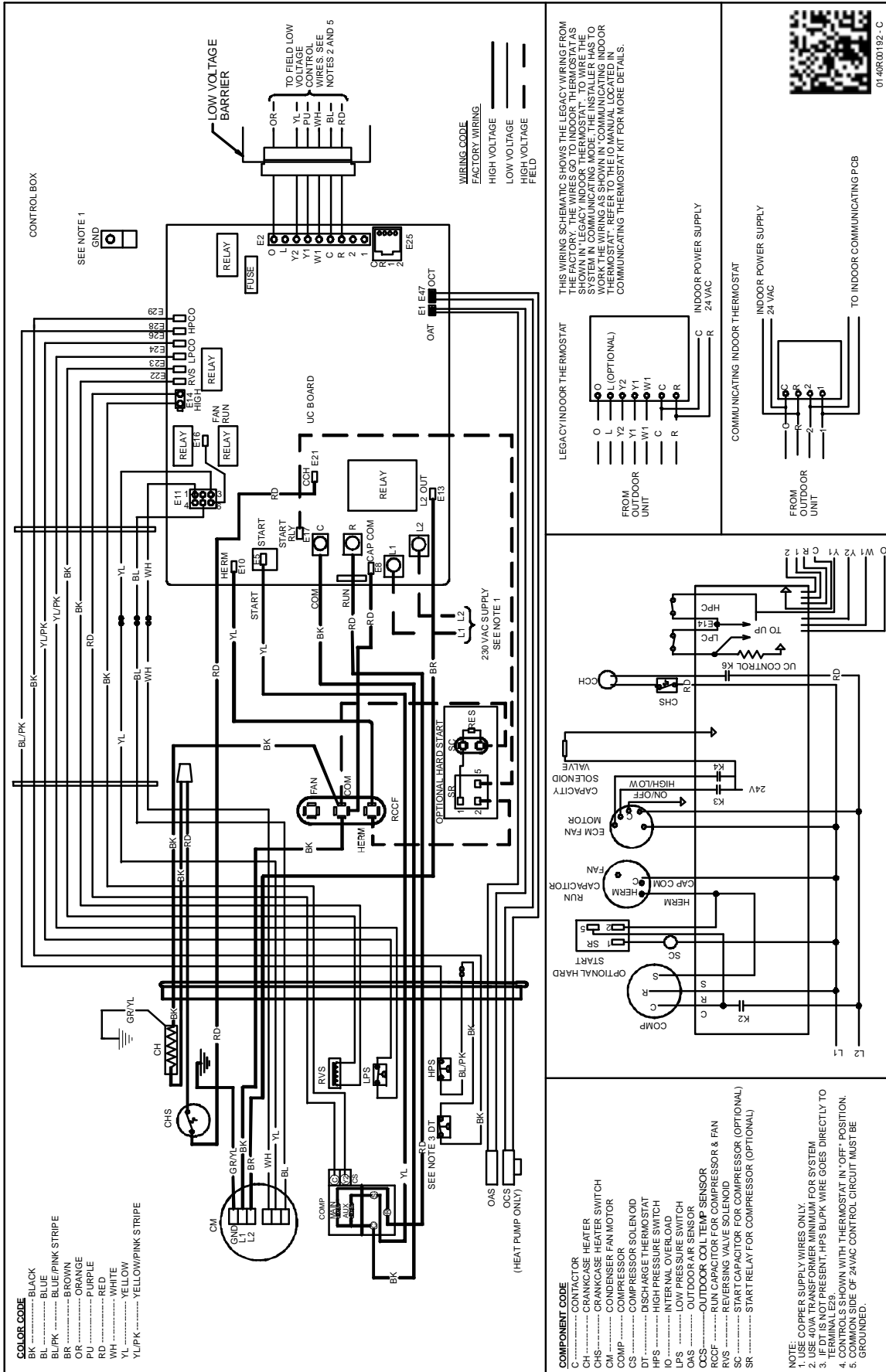

Wiring is subject to change. Always refer to the wiring diagram on the unit for the most up-to-date wiring.



**WARNING**  
**HIGH VOLTAGE!**  
 DISCONNECT ALL POWER BEFORE SERVICING OR INSTALLING THIS UNIT. MULTIPLE POWER SOURCES MAY BE PRESENT. FAILURE TO DO SO MAY CAUSE PROPERTY DAMAGE, PERSONAL INJURY OR DEATH.

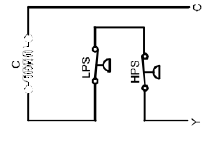
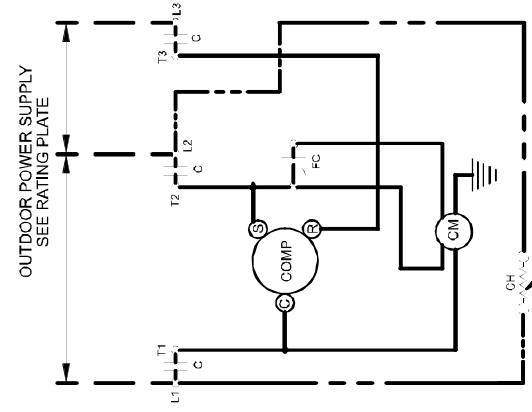
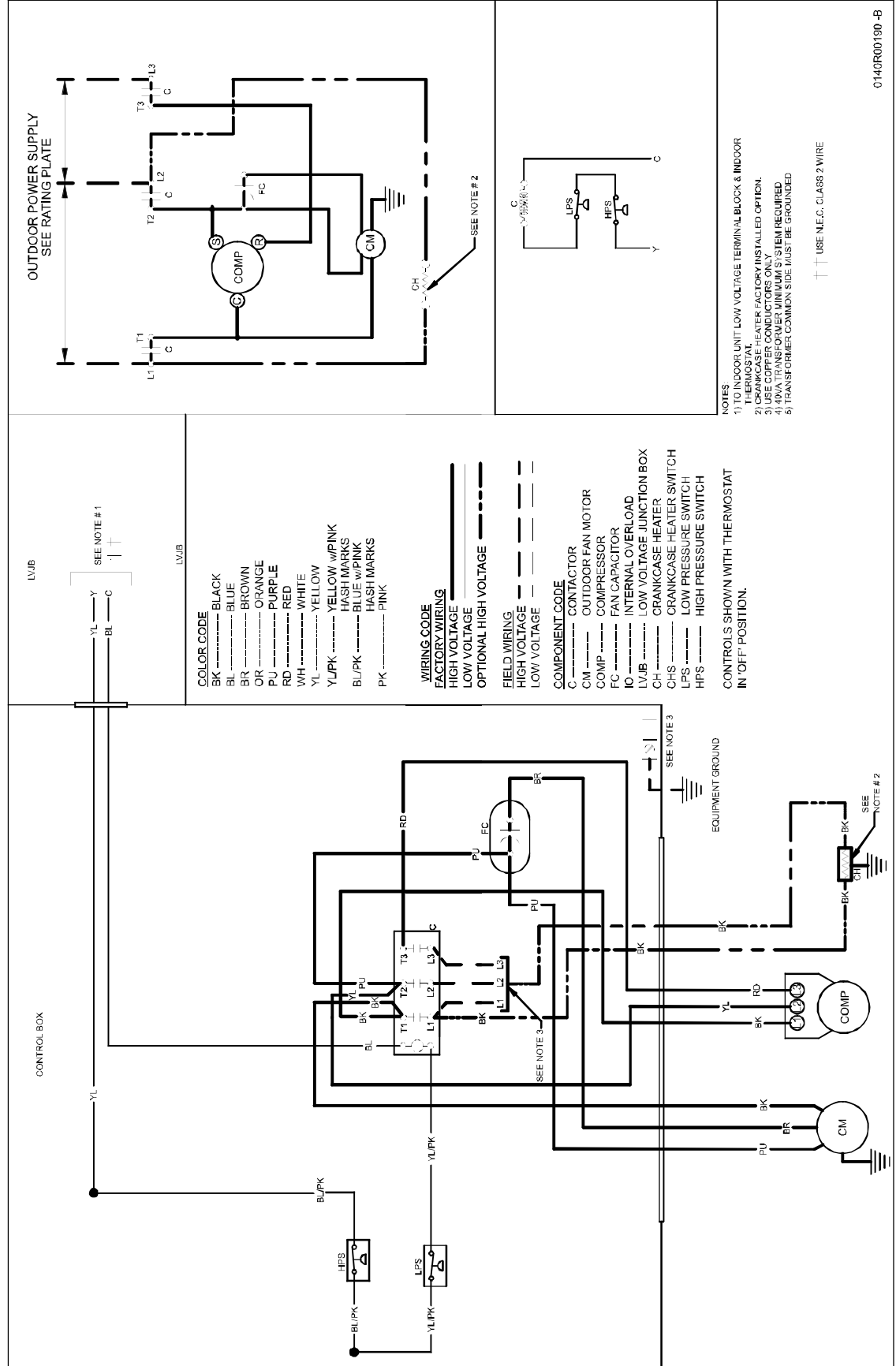

- COLOR CODE**
- BK ----- BLACK
  - BL ----- BLUE
  - BR ----- BROWN
  - OR ----- ORANGE
  - PU ----- PURPLE
  - RD ----- RED
  - WH ----- WHITE
  - YL ----- YELLOW
  - YL/PK ----- YELLOW w/PINK
  - BL/PK ----- BLUE w/PINK
  - PK ----- PINK

- WIRING CODE**
- FACTORY WIRING
  - HIGH VOLTAGE
  - LOW VOLTAGE
  - OPTIONAL HIGH VOLTAGE

- FIELD WIRING**
- HIGH VOLTAGE
  - LOW VOLTAGE

- COMPONENT CODE**
- C ----- CONTACTOR
  - CM ----- OUTDOOR FAN MOTOR
  - COMP ----- COMPRESSOR
  - FC ----- FAN CAPACITOR
  - IO ----- INTERNAL OVERLOAD
  - LVJB ----- LOW VOLTAGE JUNCTION BOX
  - CH ----- CRANKCASE HEATER
  - CHS ----- CRANKCASE HEATER SWITCH
  - LPS ----- LOW PRESSURE SWITCH
  - HPS ----- HIGH PRESSURE SWITCH

CONTROLS SHOWN WITH THERMOSTAT IN 'OFF' POSITION.

- NOTES**
- 1) TO INDOOR UNIT LOW VOLTAGE TERMINAL BLOCK & INDOOR FAN MOTOR. HEATER FACTORY INSTALLED OPTIONAL.
  - 2) USE COPPER CONDUCTORS ONLY.
  - 3) USE COPPER CONDUCTORS ONLY.
  - 4) 10VA TRANSFORMER MINIMUM SYSTEM REQUIRED
  - 5) TRANSFORMER COMMON SIDE MUST BE GROUNDED

+++ USE N.E.C. CLASS 2 WIRE

0140R00190-B

Wiring is subject to change. Always refer to the wiring diagram on the unit for the most up-to-date wiring.





**WARNING**  
**HIGH VOLTAGE!**  
 DISCONNECT ALL POWER BEFORE SERVICING OR INSTALLING THIS UNIT. MULTIPLE POWER SOURCES MAY BE PRESENT. FAILURE TO DO SO MAY CAUSE PROPERTY DAMAGE, PERSONAL INJURY OR DEATH.

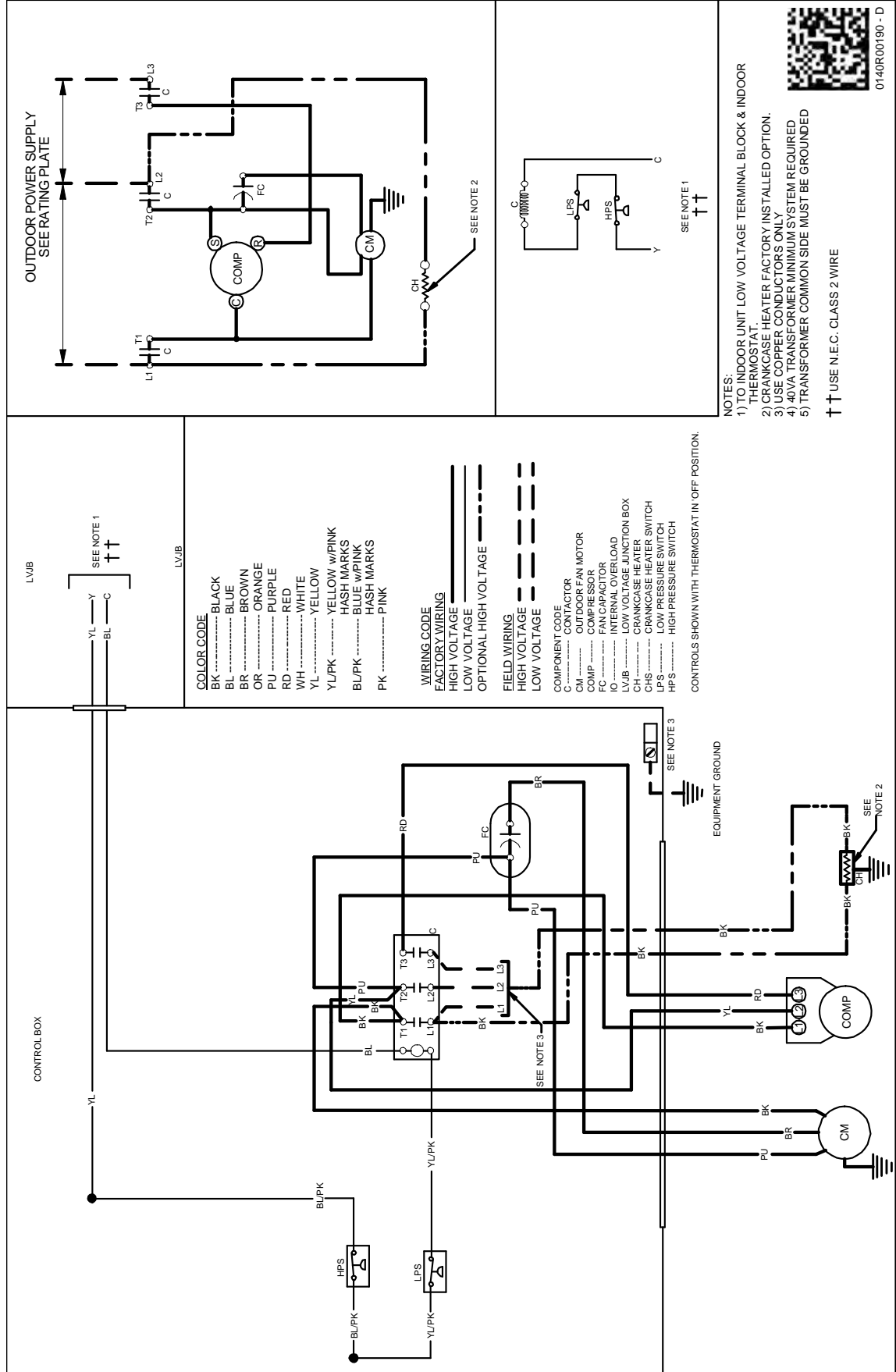

0140R00190-D

Wiring is subject to change. Always refer to the wiring diagram on the unit for the most up-to-date wiring.

**WARNING**

**HIGH VOLTAGE!**  
 DISCONNECT ALL POWER BEFORE SERVICING OR INSTALLING THIS UNIT. MULTIPLE POWER SOURCES MAY BE PRESENT. FAILURE TO DO SO MAY CAUSE PROPERTY DAMAGE, PERSONAL INJURY OR DEATH.

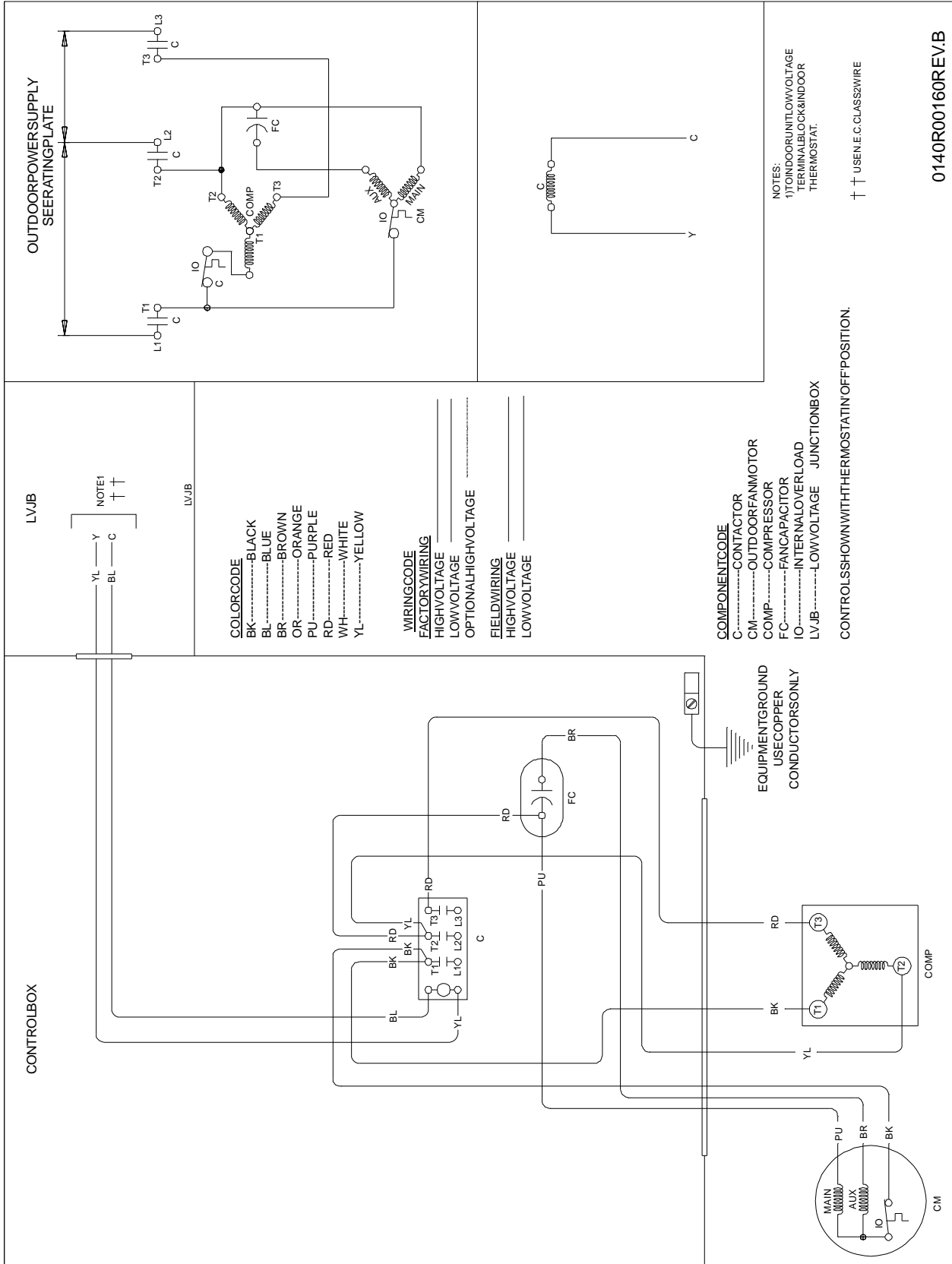

0140R00160REV/B

Wiring is subject to change. Always refer to the wiring diagram on the unit for the most up-to-date wiring.

# WIRING DIAGRAMS

# GSX130[36-61][3, 4]A\* / 3-Phase



**WARNING**  
**HIGH VOLTAGE!**  
 DISCONNECT ALL POWER BEFORE SERVICING OR INSTALLING THIS UNIT. MULTIPLE POWER SOURCES MAY BE PRESENT. FAILURE TO DO SO MAY CAUSE PROPERTY DAMAGE, PERSONAL INJURY OR DEATH.

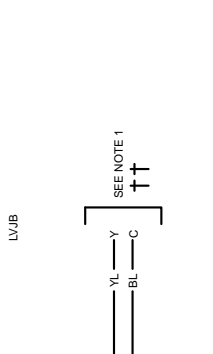
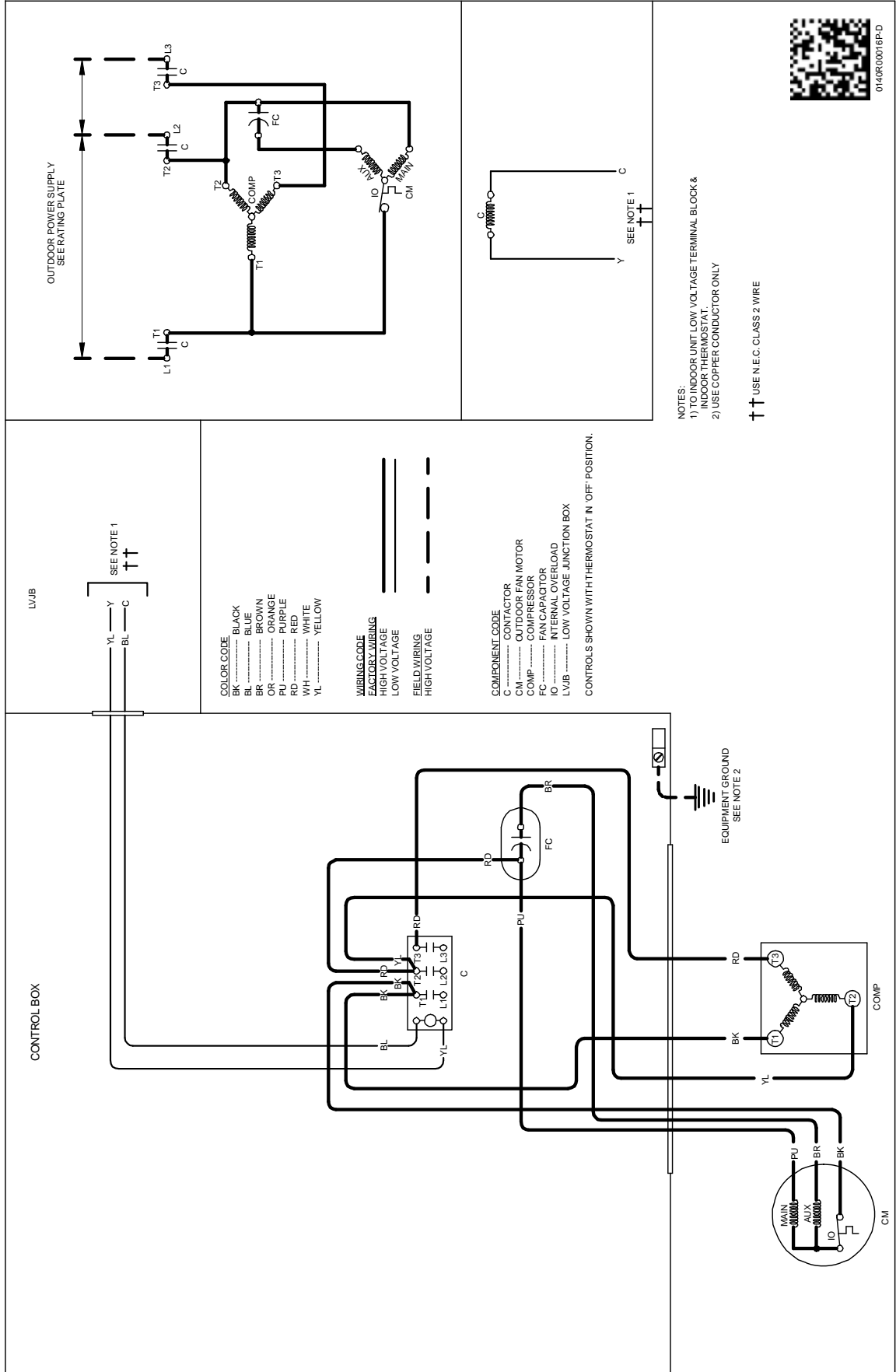

- COLOR CODE**  
 BK ..... BLACK  
 BR ..... BLUE/WHITE  
 OR ..... ORANGE  
 PU ..... PURPLE  
 RD ..... RED  
 WH ..... WHITE  
 YL ..... YELLOW

- WIRING CODE**  
 BK ..... BLACK WIRING  
 HV ..... HIGH VOLTAGE  
 LW ..... LOW VOLTAGE  
 FV ..... FIELD WIRING  
 HV ..... HIGH VOLTAGE

- COMPONENT CODE**  
 C ..... CONTACTOR  
 CM ..... OUTDOOR FAN MOTOR  
 COMP ..... COMPRESSOR  
 FC ..... FAN CAPACITOR  
 IO ..... INTERNAL OVERLOAD  
 LVJB ..... LOW VOLTAGE JUNCTION BOX

CONTROLS SHOWN WITH THERMOSTAT IN 'OFF' POSITION.



NOTES:  
 1) TO INDOOR UNIT, LOW VOLTAGE TERMINAL BLOCK & INDOOR THERMOSTAT.  
 2) USE COPPER CONDUCTOR ONLY

†† USE N.E.C. CLASS 2 WIRE



0148R00016P-D

Wiring is subject to change. Always refer to the wiring diagram on the unit for the most up-to-date wiring.



# WIRING DIAGRAMS

GSX130[18-60]1B\* / GSX130[18 & 36]1C\*  
 GSX130[18-36]1D\* / GSX130361E\* / GSX130611A\*  
 Single-Phase



**WARNING**

**HIGH VOLTAGE!**  
 DISCONNECT ALL POWER BEFORE SERVICING OR INSTALLING THIS UNIT. MULTIPLE POWER SOURCES MAY BE PRESENT. FAILURE TO DO SO MAY CAUSE PROPERTY DAMAGE, PERSONAL INJURY OR DEATH.

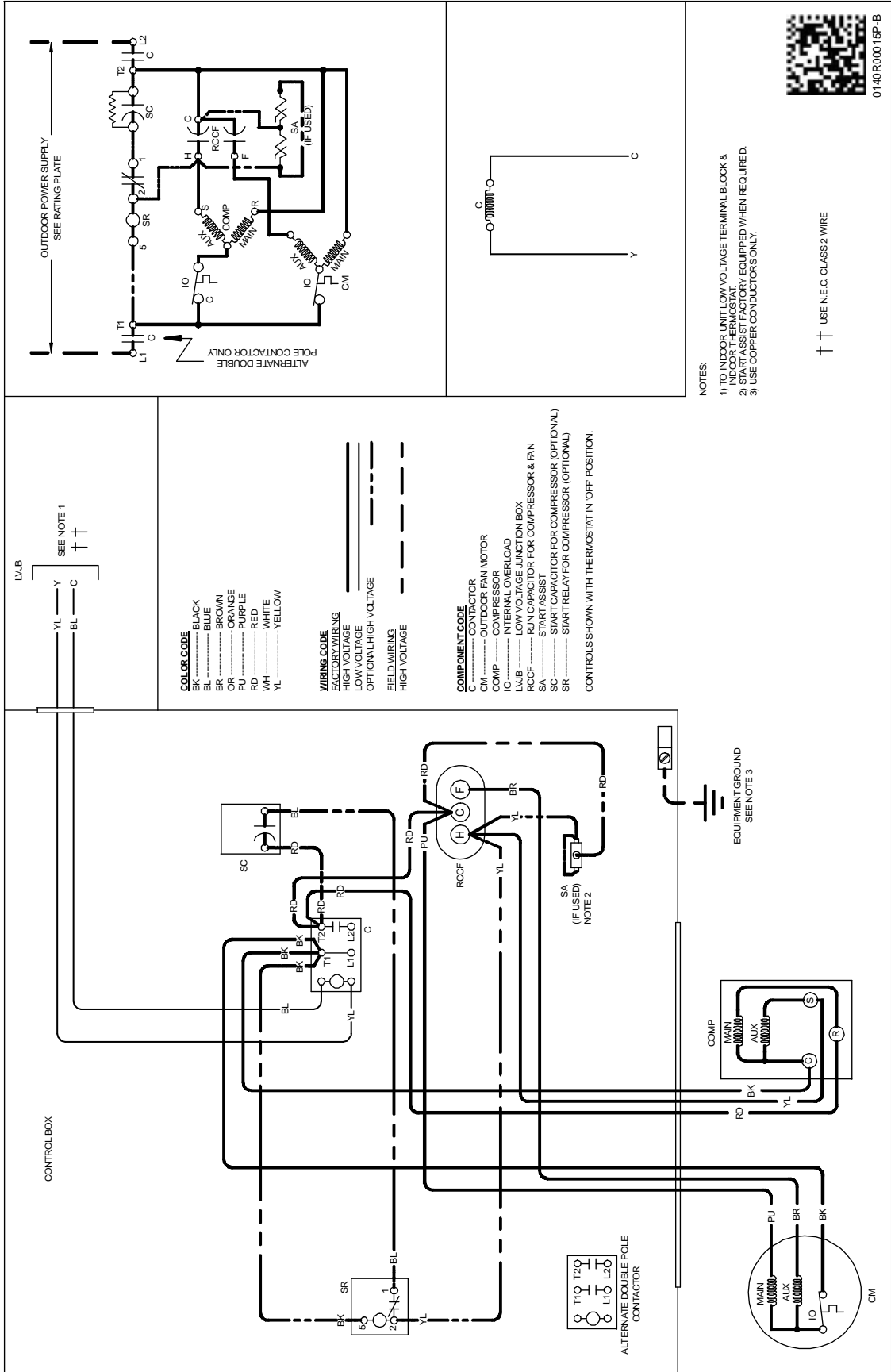

01-40 R00015P-B

- NOTES:
- 1) TO INDOOR UNIT, LOW VOLTAGE TERMINAL BLOCK & INDOOR THERMOSTAT
  - 2) START ASSIST FACTORY EQUIPPED WHEN REQUIRED.
  - 3) USE COPPER CONDUCTORS ONLY.

↑↑ USE N.E.C. CLASS 2 WIRE

Wiring is subject to change. Always refer to the wiring diagram on the unit for the most up-to-date wiring.



**HIGH VOLTAGE!**  
**DISCONNECT ALL POWER BEFORE SERVICING OR INSTALLING THIS UNIT. MULTIPLE POWER SOURCES MAY BE PRESENT. FAILURE TO DO SO MAY CAUSE PROPERTY DAMAGE, PERSONAL INJURY OR DEATH.**

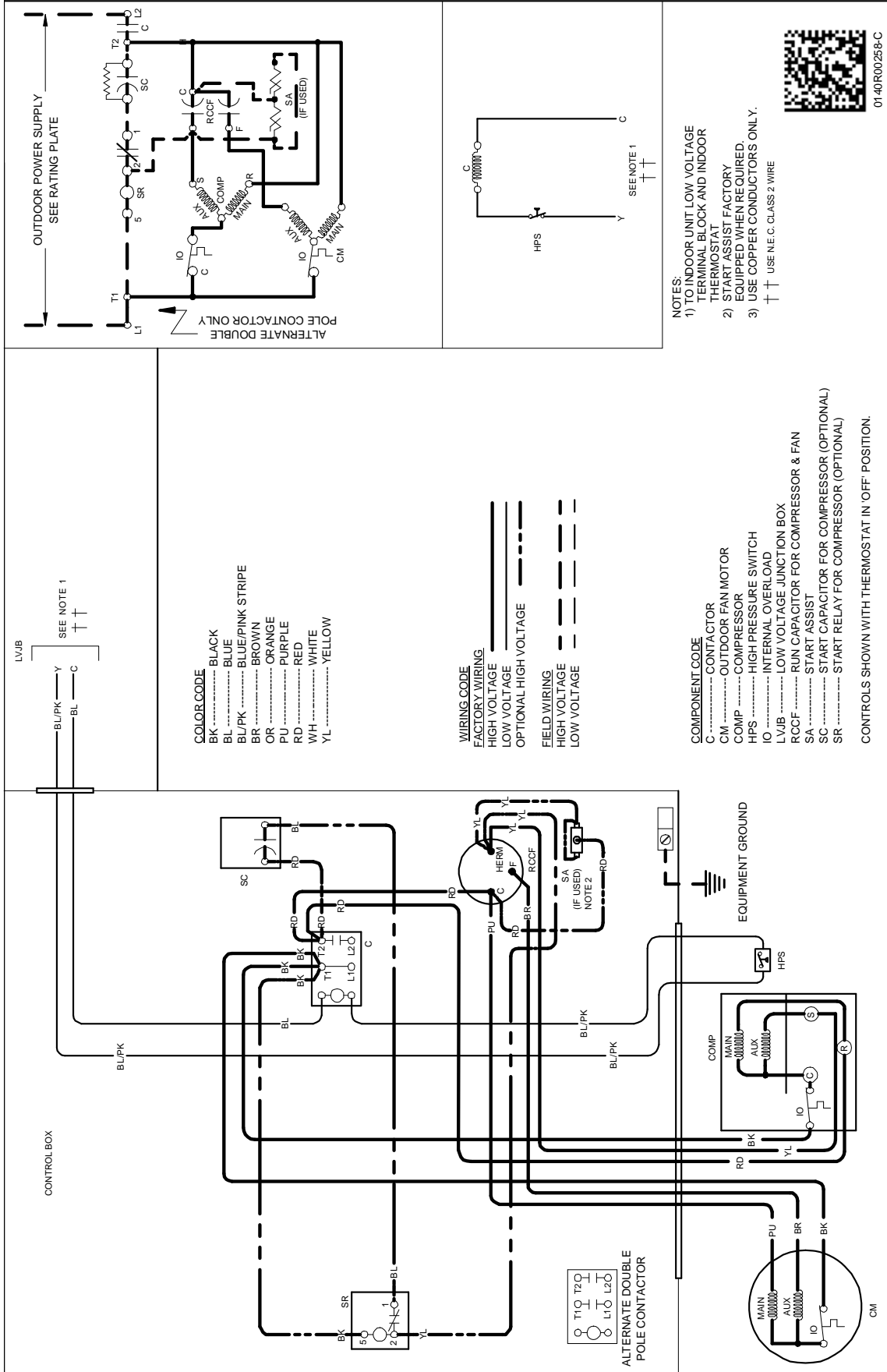

Wiring is subject to change. Always refer to the wiring diagram on the unit for the most up-to-date wiring.



**WARNING**  
**HIGH VOLTAGE!**  
 DISCONNECT ALL POWER BEFORE SERVICING OR INSTALLING THIS UNIT. MULTIPLE POWER SOURCES MAY BE PRESENT. FAILURE TO DO SO MAY CAUSE PROPERTY DAMAGE, PERSONAL INJURY OR DEATH.

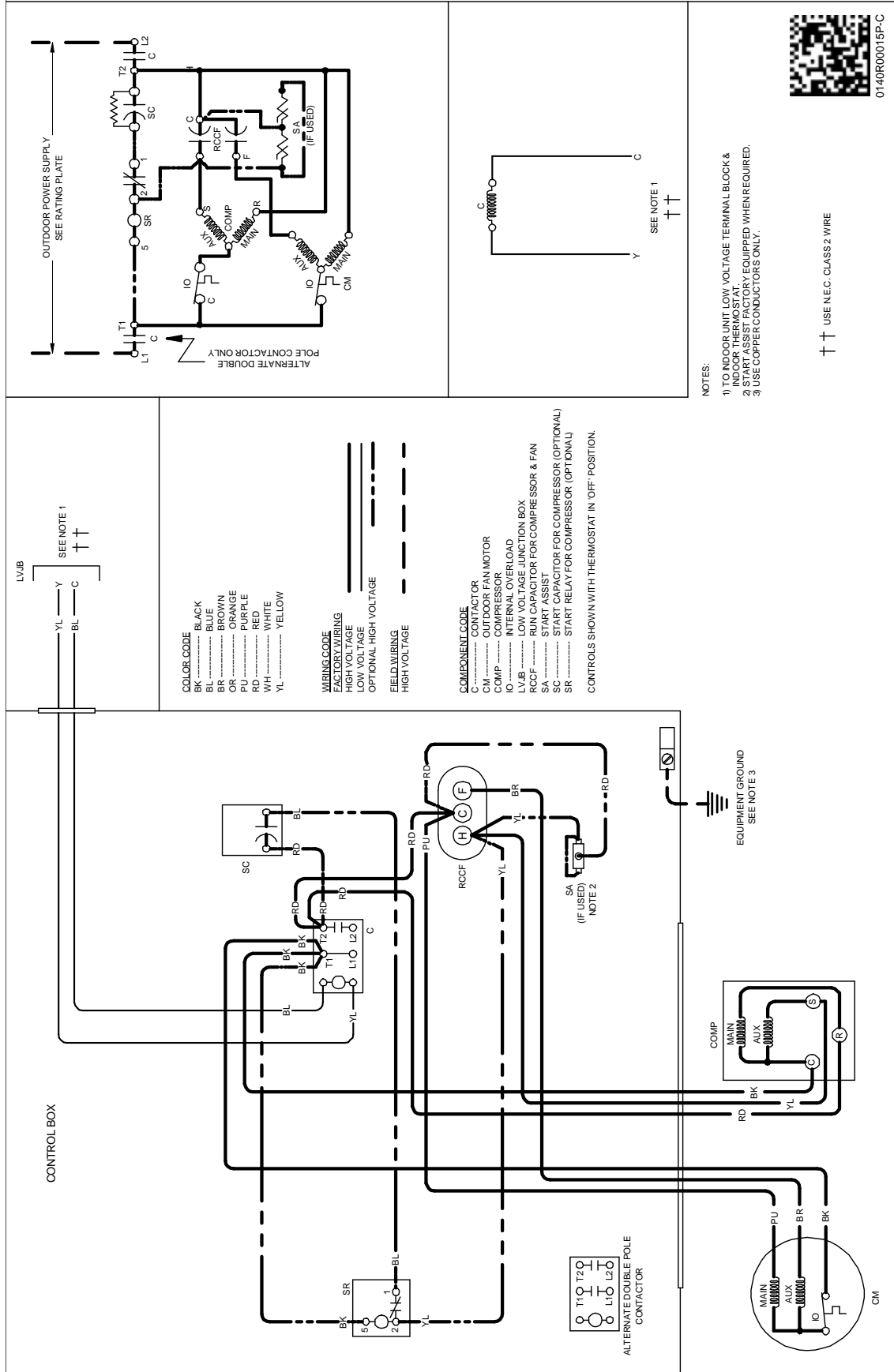

0140R0001SP-C

Wiring is subject to change. Always refer to the wiring diagram on the unit for the most up-to-date wiring.



**WARNING**  
**HIGH VOLTAGE!**  
 DISCONNECT ALL POWER BEFORE SERVICING OR INSTALLING THIS UNIT. MULTIPLE POWER SOURCES MAY BE PRESENT. FAILURE TO DO SO MAY CAUSE PROPERTY DAMAGE, PERSONAL INJURY OR DEATH.

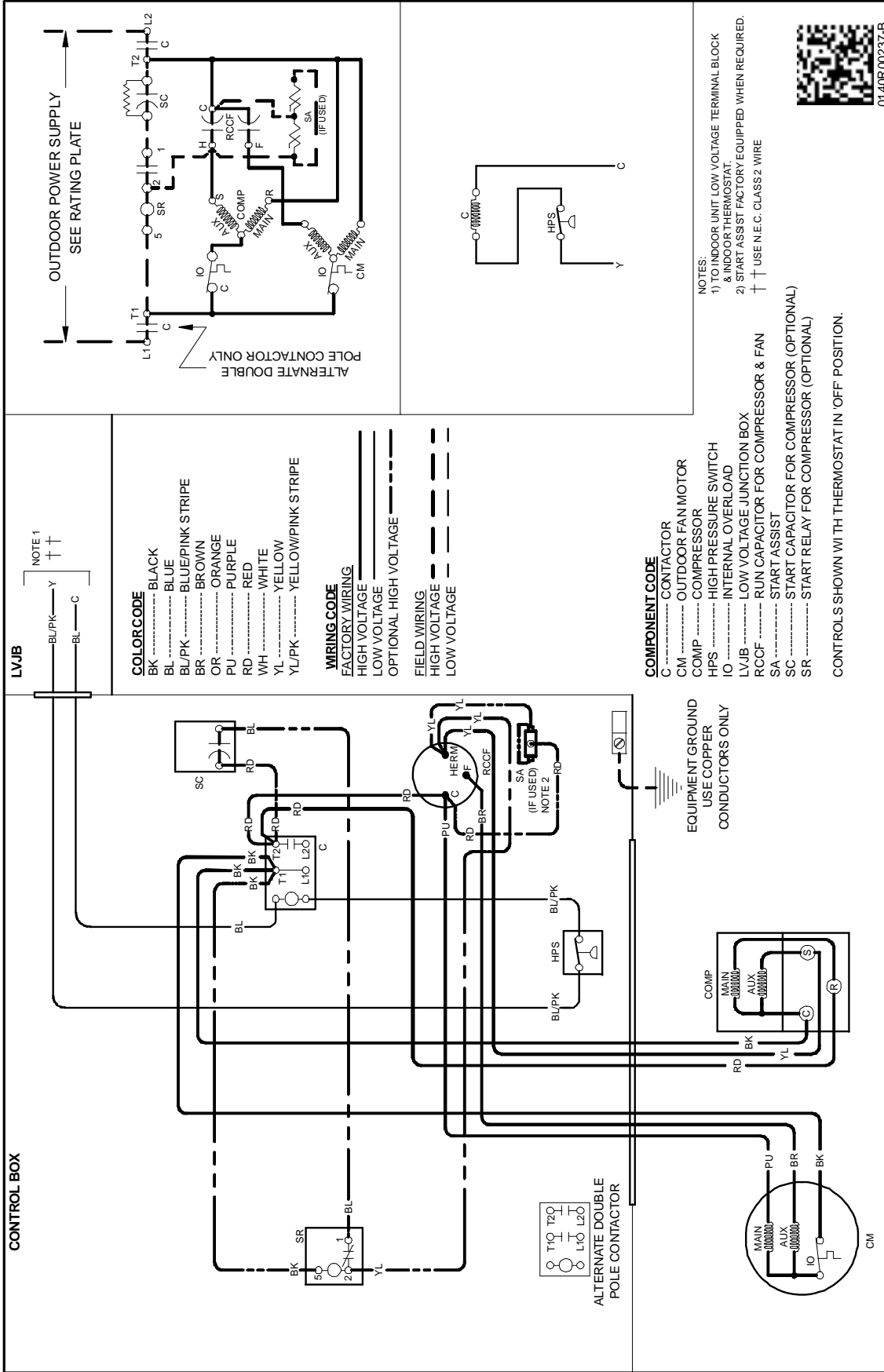

0140R00237-B

Wiring is subject to change. Always refer to the wiring diagram on the unit for the most up-to-date wiring.



**WARNING**  
**HIGH VOLTAGE!**  
 DISCONNECT ALL POWER BEFORE SERVICING OR INSTALLING THIS UNIT. MULTIPLE POWER SOURCES MAY BE PRESENT. FAILURE TO DO SO MAY CAUSE PROPERTY DAMAGE, PERSONAL INJURY OR DEATH.

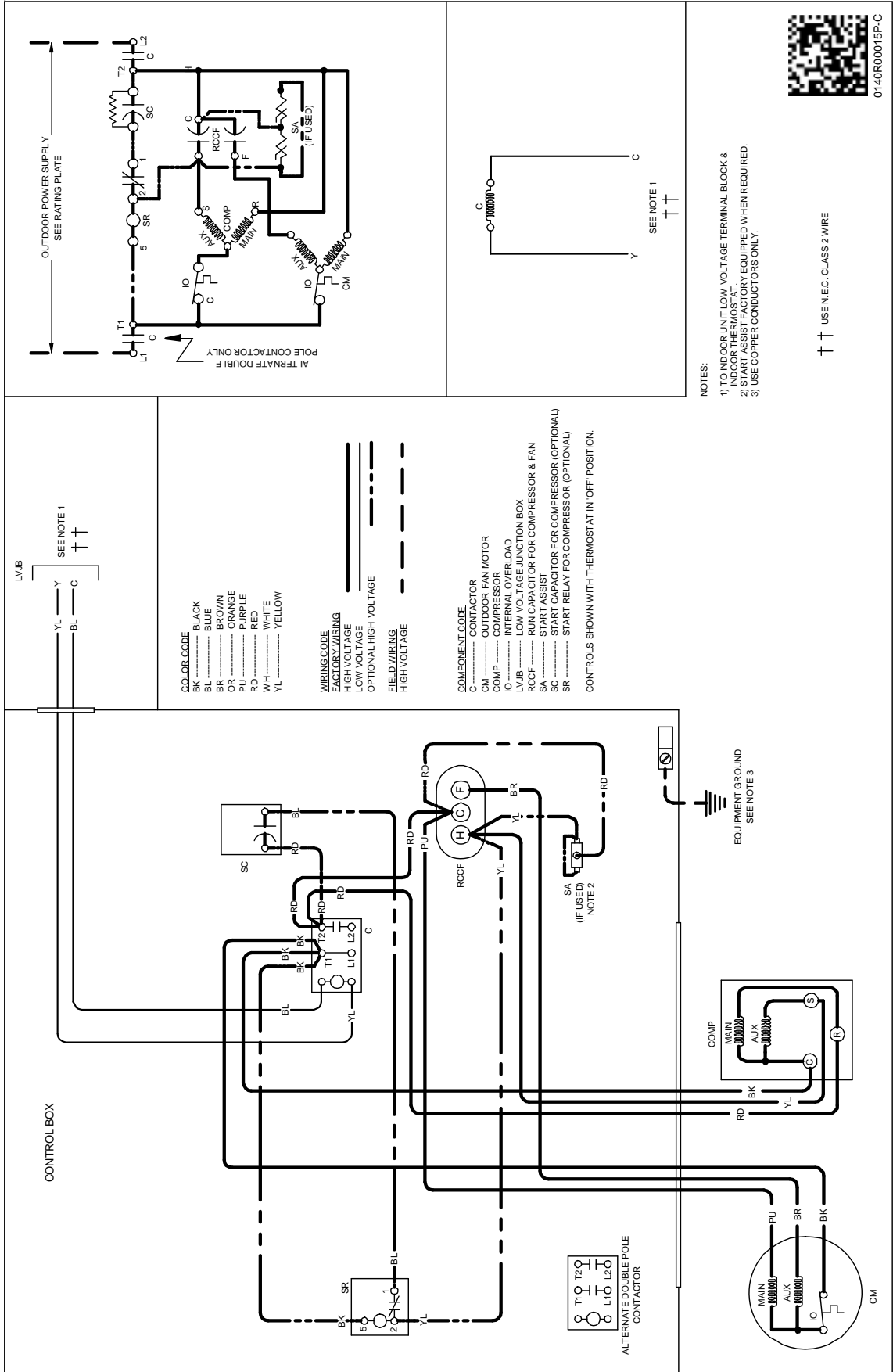

Wiring is subject to change. Always refer to the wiring diagram on the unit for the most up-to-date wiring.



**WARNING**  
**HIGH VOLTAGE!**  
 DISCONNECT ALL POWER BEFORE SERVICING OR INSTALLING THIS UNIT. MULTIPLE POWER SOURCES MAY BE PRESENT. FAILURE TO DO SO MAY CAUSE PROPERTY DAMAGE, PERSONAL INJURY OR DEATH.

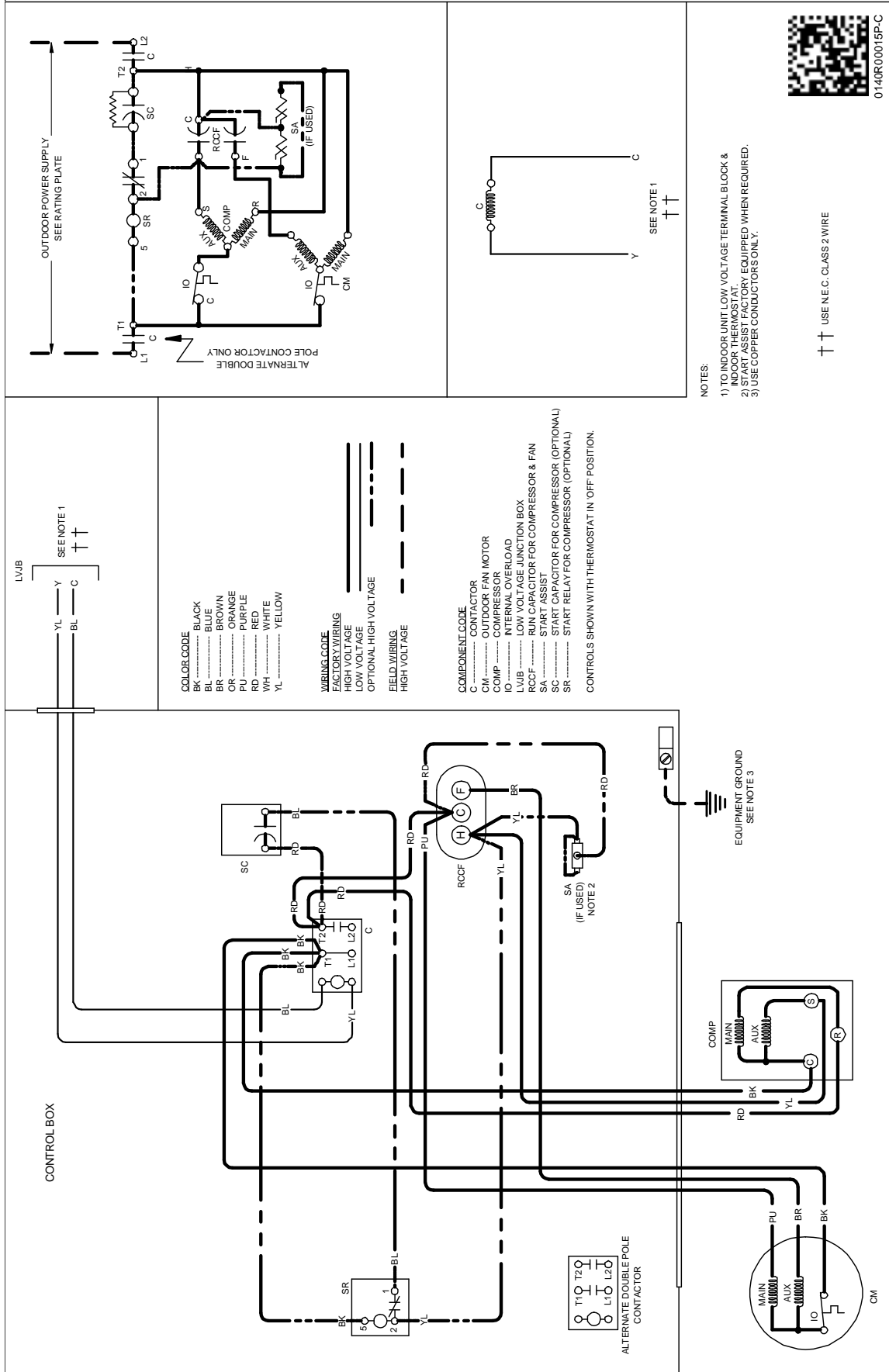

Wiring is subject to change. Always refer to the wiring diagram on the unit for the most up-to-date wiring.





**WARNING**  
**HIGH VOLTAGE!**  
 DISCONNECT ALL POWER BEFORE SERVICING OR INSTALLING THIS UNIT. MULTIPLE POWER SOURCES MAY BE PRESENT. FAILURE TO DO SO MAY CAUSE PROPERTY DAMAGE, PERSONAL INJURY OR DEATH.

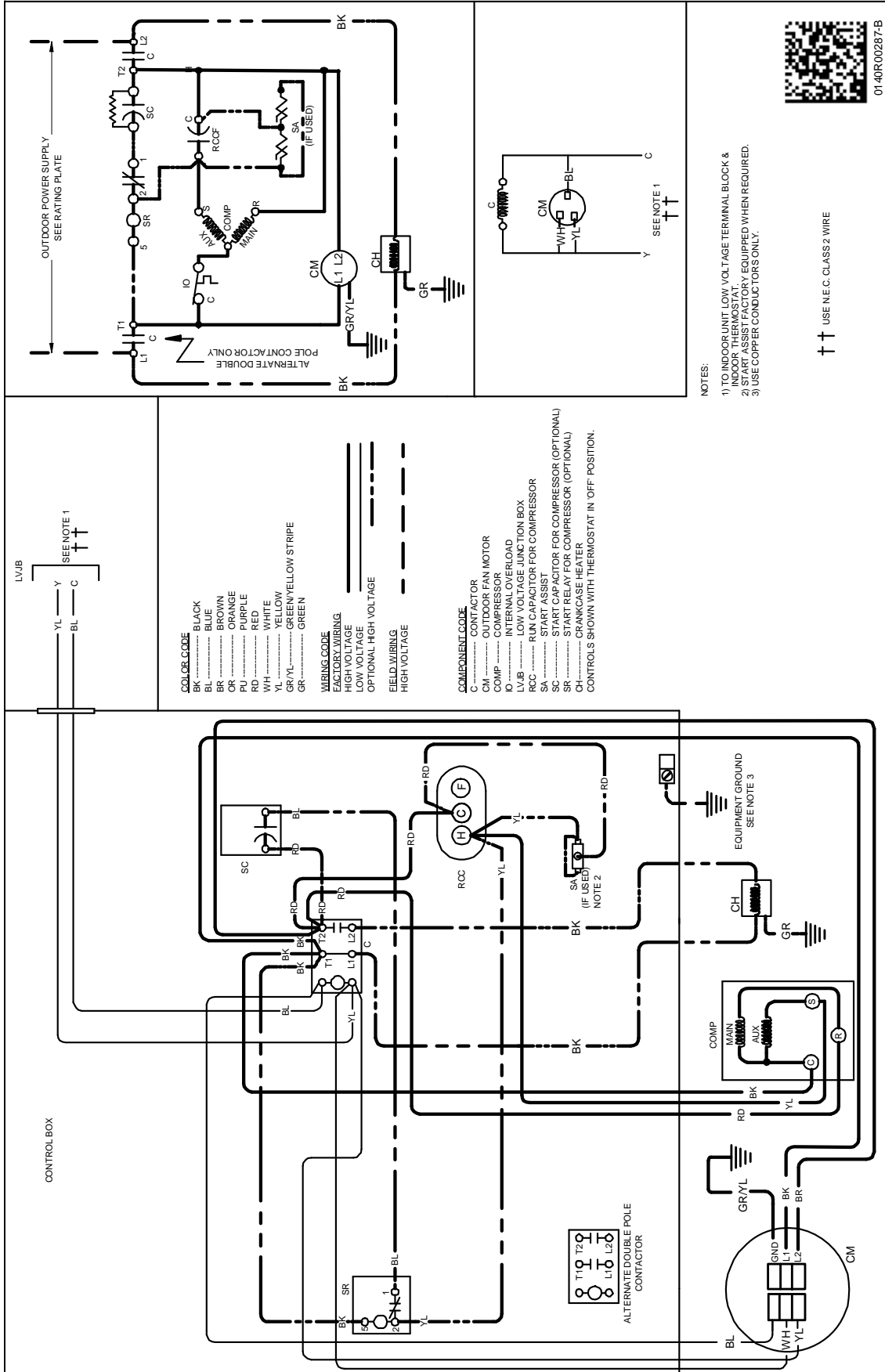

01 40R00287-B

Wiring is subject to change. Always refer to the wiring diagram on the unit for the most up-to-date wiring.



**WARNING**  
 HIGH VOLTAGE!  
 DISCONNECT ALL POWER BEFORE SERVICING OR INSTALLING THIS UNIT. MULTIPLE POWER SOURCES MAY BE PRESENT. FAILURE TO DO SO MAY CAUSE PROPERTY DAMAGE, PERSONAL INJURY OR DEATH.

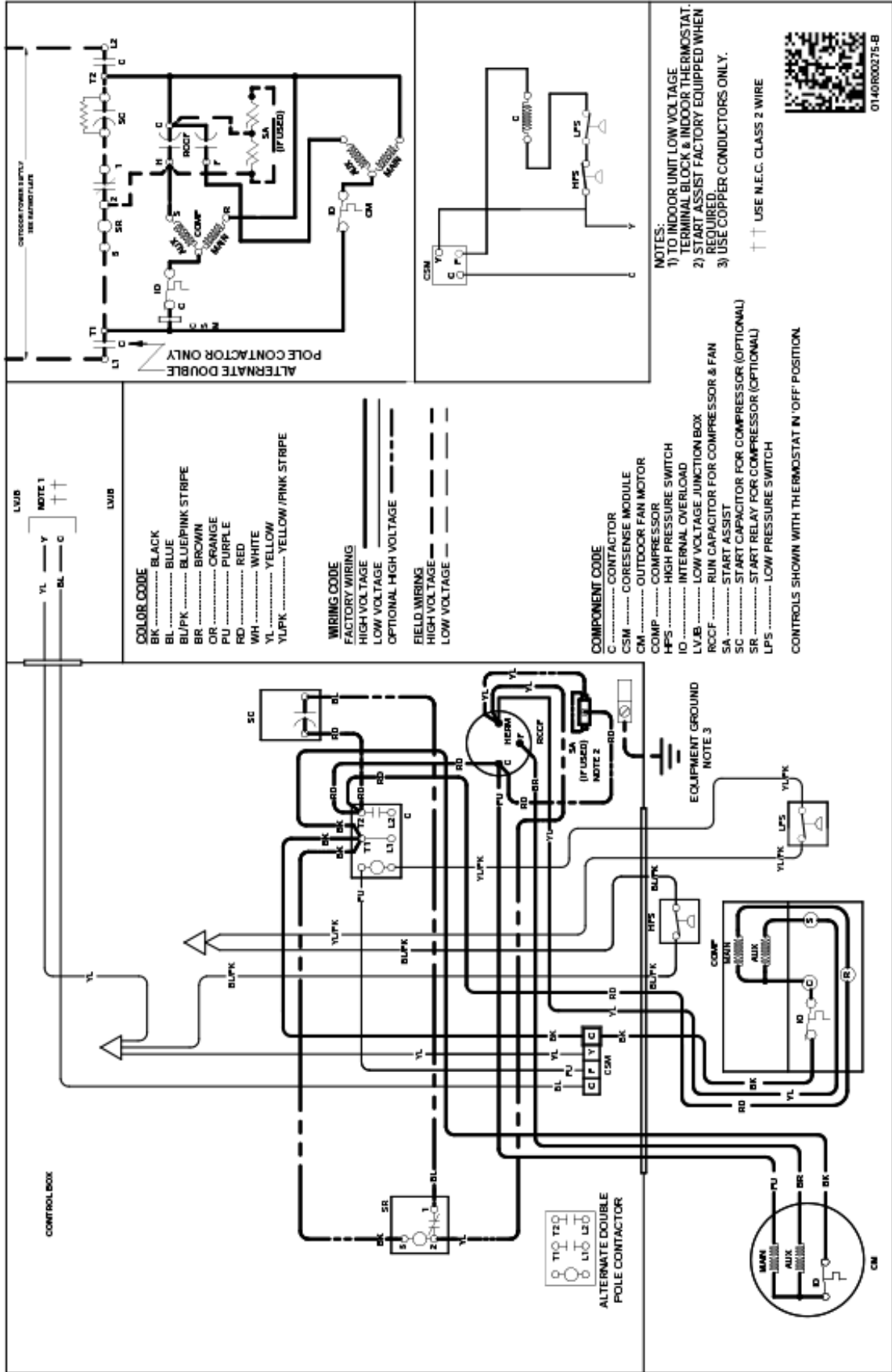

**COLOR CODE**

|       |                    |
|-------|--------------------|
| BK    | BLACK              |
| BL    | BLUE               |
| BL/PK | BLUE/PINK STRIPE   |
| BR    | BROWN              |
| OR    | ORANGE             |
| PU    | PURPLE             |
| WH    | WHITE              |
| YL    | YELLOW             |
| YL/PK | YELLOW/PINK STRIPE |

**WIRING CODE**

|     |                       |
|-----|-----------------------|
| --- | FACTORY WIRING        |
| --- | HIGH VOLTAGE          |
| --- | OPTIONAL HIGH VOLTAGE |
| --- | FIELD WIRING          |
| --- | HIGH VOLTAGE          |
| --- | LOW VOLTAGE           |

- COMPONENT CODE**
- C CONTACTOR
  - CSM CORE SENSE MODULE
  - CM OUTDOOR FAN MOTOR
  - COMP COMPRESSOR
  - HF'S HIGH PRESSURE SWITCH
  - IO INTERNAL OVERLOAD
  - LVJB LOW VOLTAGE JUNCTION BOX
  - RC/RN RUN CAPACITOR FOR COMPRESSOR & FAN
  - SA START ASSIST
  - SR START RELAY FOR COMPRESSOR (OPTIONAL)
  - SC START RELAY FOR COMPRESSOR (OPTIONAL)
  - LPS LOW PRESSURE SWITCH

**NOTES:**

- TO INDOOR UNIT LOW VOLTAGE TERMINAL BLOCK & INDOOR THERMOSTAT.
- START ASSIST FACTORY EQUIPPED WHEN REQUIRED.
- USE COPPER CONDUCTORS ONLY.

†† USE N.E.C. CLASS 2 WIRE



0140R00275-B

Wiring is subject to change. Always refer to the wiring diagram on the unit for the most up-to-date wiring.



**WARNING**  
**HIGH VOLTAGE!**  
 DISCONNECT ALL POWER BEFORE SERVICING OR INSTALLING THIS UNIT. MULTIPLE POWER SOURCES MAY BE PRESENT. FAILURE TO DO SO MAY CAUSE PROPERTY DAMAGE, PERSONAL INJURY OR DEATH.

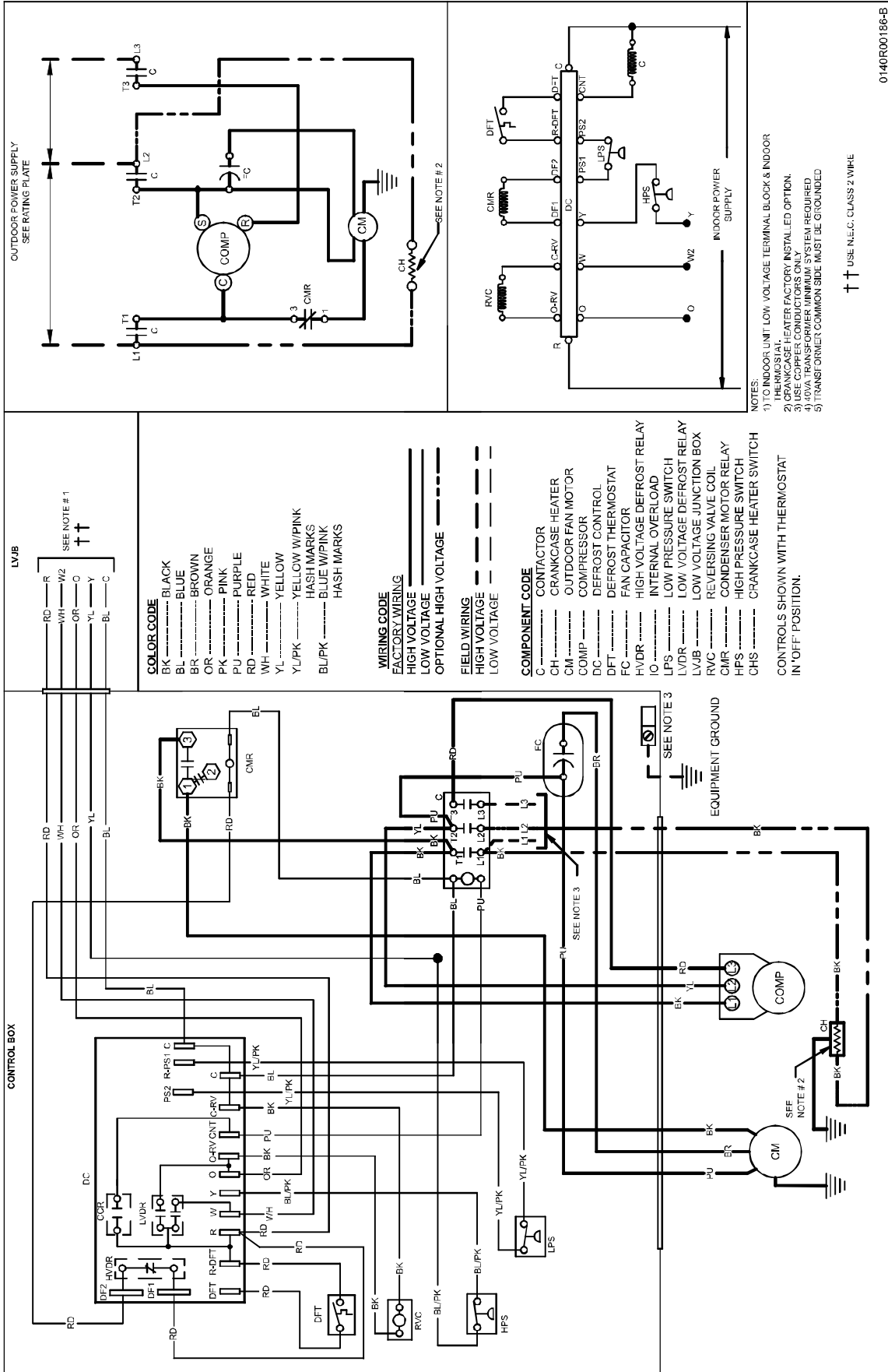

Wiring is subject to change. Always refer to the wiring diagram on the unit for the most up-to-date wiring.





**WARNING**  
**HIGH VOLTAGE!**  
 DISCONNECT ALL POWER BEFORE SERVICING OR INSTALLING THIS UNIT. MULTIPLE POWER SOURCES MAY BE PRESENT. FAILURE TO DO SO MAY CAUSE PROPERTY DAMAGE, PERSONAL INJURY OR DEATH.

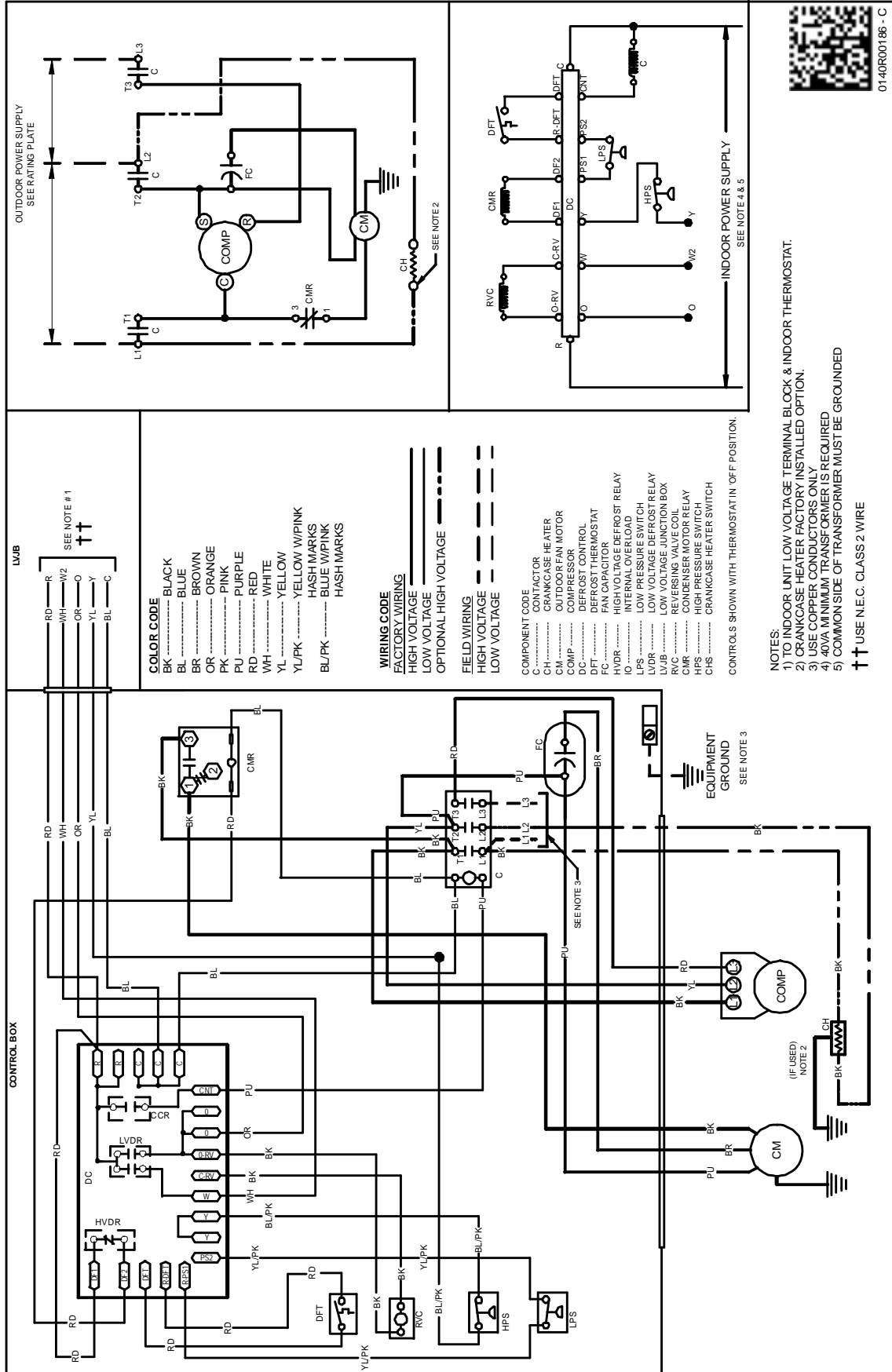

0140R00186 - C

Wiring is subject to change. Always refer to the wiring diagram on the unit for the most up-to-date wiring.

WARNING

HIGH VOLTAGE!  
DISCONNECT ALL POWER BEFORE SERVICING OR INSTALLING THIS UNIT. MULTIPLE POWER SOURCES MAY BE PRESENT. FAILURE TO DO SO MAY CAUSE PROPERTY DAMAGE, PERSONAL INJURY OR DEATH.

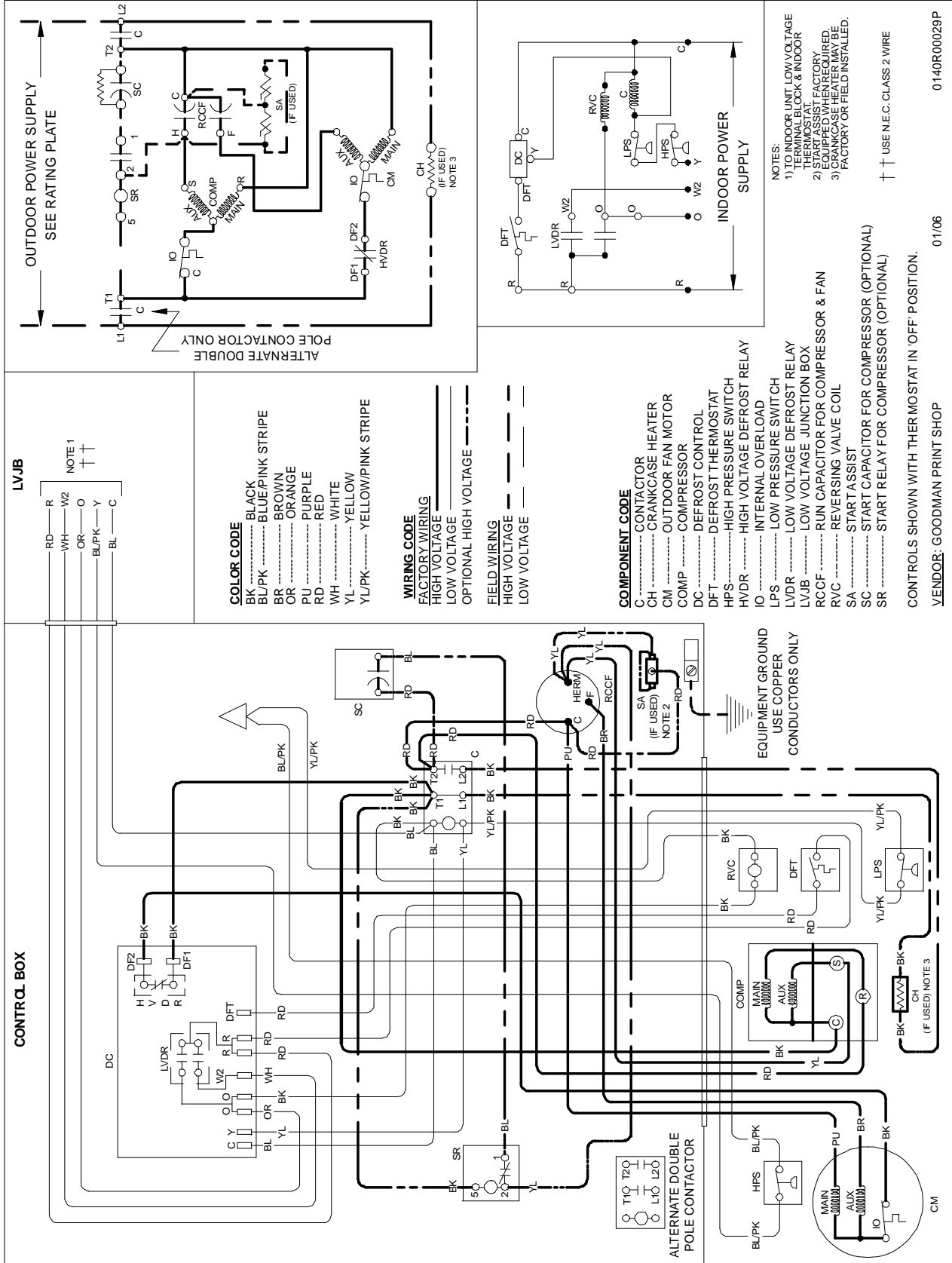

0140R00029P

01/06

Wiring is subject to change. Always refer to the wiring diagram on the unit for the most up-to-date wiring.

# WIRING DIAGRAMS

GSZ130181AC, GSZ130241BB, GSZ130301AD, GSZ130361B\*  
GSZ130421A\*, GSZ130481AC, GSZ130601AC

**WARNING**  
HIGH VOLTAGE!  
DISCONNECT ALL POWER BEFORE SERVICING OR INSTALLING THIS UNIT. MULTIPLE POWER SOURCES MAY BE PRESENT. FAILURE TO DO SO MAY CAUSE PROPERTY DAMAGE, PERSONAL INJURY OR DEATH.

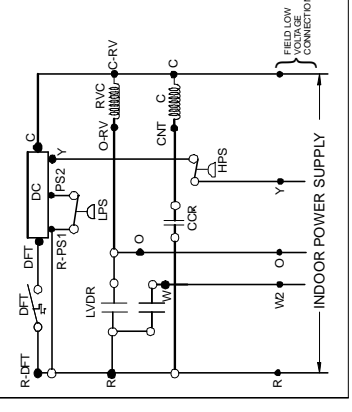
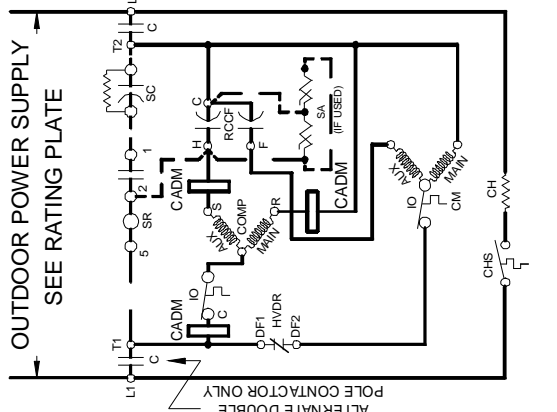
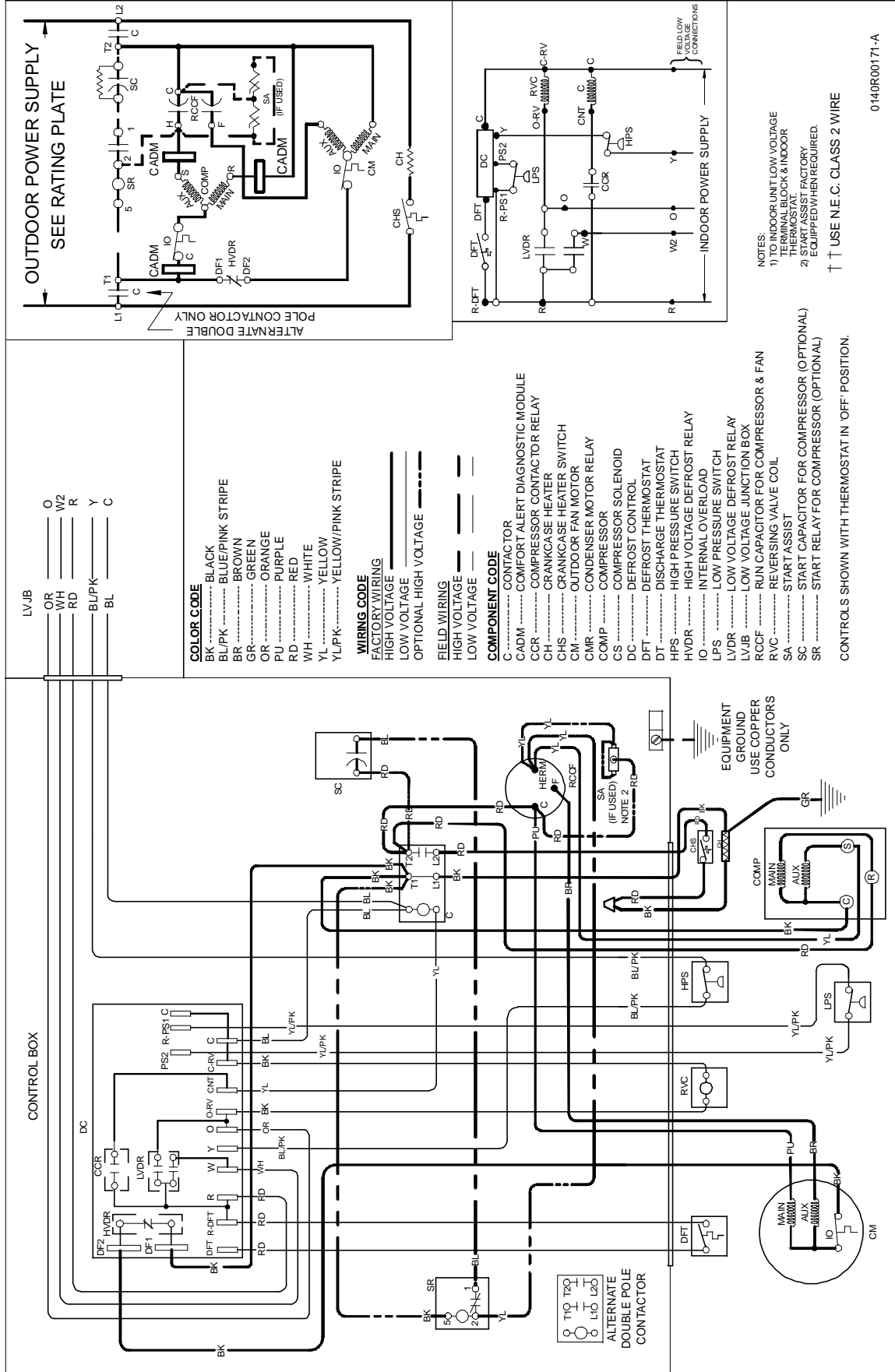

- LV/JB
- OR \_\_\_\_\_ O
  - WH \_\_\_\_\_ W2
  - RD \_\_\_\_\_ R
  - BL/PK \_\_\_\_\_ Y
  - BL \_\_\_\_\_ C

- COLOR CODE**
- BK ..... BLACK
  - BL/PK ..... BLUE/PINK STRIPE
  - BR ..... BROWN
  - GR ..... GREEN
  - OR ..... ORANGE
  - PU ..... PURPLE
  - RD ..... RED
  - WH ..... WHITE
  - YL ..... YELLOW
  - YL/PK ..... YELLOW/PINK STRIPE
- WIRING CODE**
- FACTORY WIRING \_\_\_\_\_
  - HIGH VOLTAGE \_\_\_\_\_
  - LOW VOLTAGE \_\_\_\_\_
  - OPTIONAL HIGH VOLTAGE \_\_\_\_\_
- FIELD WIRING**
- HIGH VOLTAGE \_\_\_\_\_
  - LOW VOLTAGE \_\_\_\_\_
- COMPONENT CODE**
- C ..... CONTACTOR
  - CADM ..... COMFORT ALERT DIAGNOSTIC MODULE
  - CCR ..... COMPRESSOR CONTACTOR RELAY
  - CH ..... CRANKCASE HEATER
  - CHS ..... CRANKCASE HEATER SWITCH
  - CM ..... OUTDOOR FAN MOTOR
  - CMR ..... CONDENSER MOTOR RELAY
  - COMP ..... COMPRESSOR
  - CS ..... COMPRESSOR SOLENOID
  - DC ..... DEFROST CONTROL
  - DFT ..... DEFROST THERMOSTAT
  - DT ..... DISCHARGE THERMOSTAT
  - HPS ..... HIGH PRESSURE SWITCH
  - HVDR ..... HIGH VOLTAGE DEFROST RELAY
  - IO ..... INTERNAL OVERLOAD
  - LPS ..... LOW PRESSURE SWITCH
  - LVDR ..... LOW VOLTAGE DEFROST RELAY
  - LVJB ..... LOW VOLTAGE JUNCTION BOX
  - RVC ..... RUN CAPACITOR FOR COMPRESSOR & FAN
  - RVC ..... REVERSING VALVE COIL
  - SA ..... START ASSIST
  - SC ..... START RELAY FOR COMPRESSOR (OPTIONAL)
  - SR ..... START RELAY FOR COMPRESSOR (OPTIONAL)

NOTES:  
1) TO INDOOR UNIT LOW VOLTAGE TERMINAL BLOCK & INDOOR THERMOSTAT FACTORY EQUIPPED WHEN REQUIRED.  
↑↑ USE N.E.C. CLASS 2 WIRE

0140R00171-A

Wiring is subject to change. Always refer to the wiring diagram on the unit for the most up-to-date wiring.





**WARNING**  
**HIGH VOLTAGE!**  
 DISCONNECT ALL POWER BEFORE SERVICING OR INSTALLING THIS UNIT. MULTIPLE POWER SOURCES MAY BE PRESENT. FAILURE TO DO SO MAY CAUSE PROPERTY DAMAGE, PERSONAL INJURY OR DEATH.

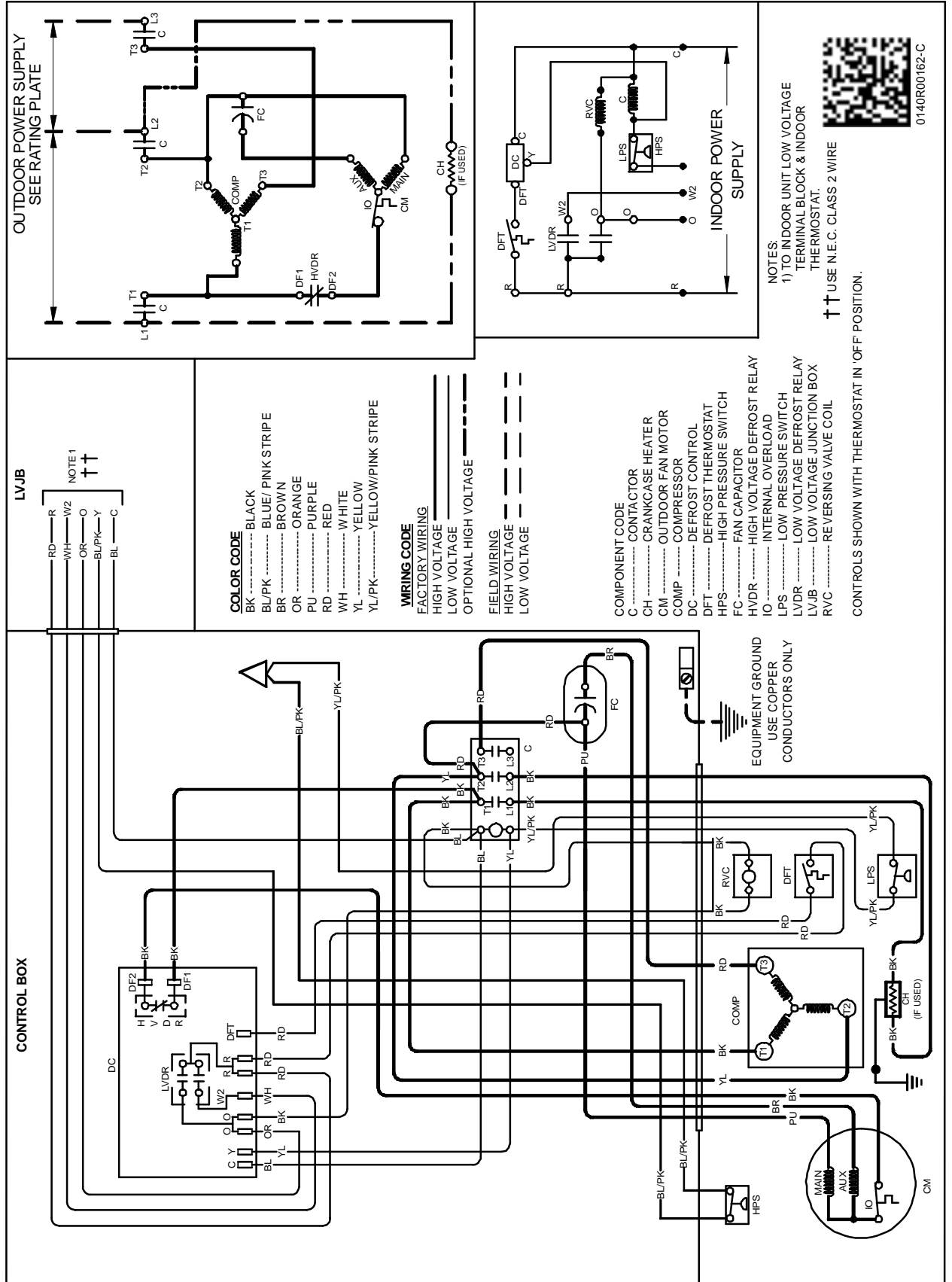

0140R00162-C

Wiring is subject to change. Always refer to the wiring diagram on the unit for the most up-to-date wiring.



**WARNING**  
**HIGH VOLTAGE!**  
 DISCONNECT ALL POWER BEFORE SERVICING OR INSTALLING THIS UNIT. MULTIPLE POWER SOURCES MAY BE PRESENT. FAILURE TO DO SO MAY CAUSE PROPERTY DAMAGE, PERSONAL INJURY OR DEATH.

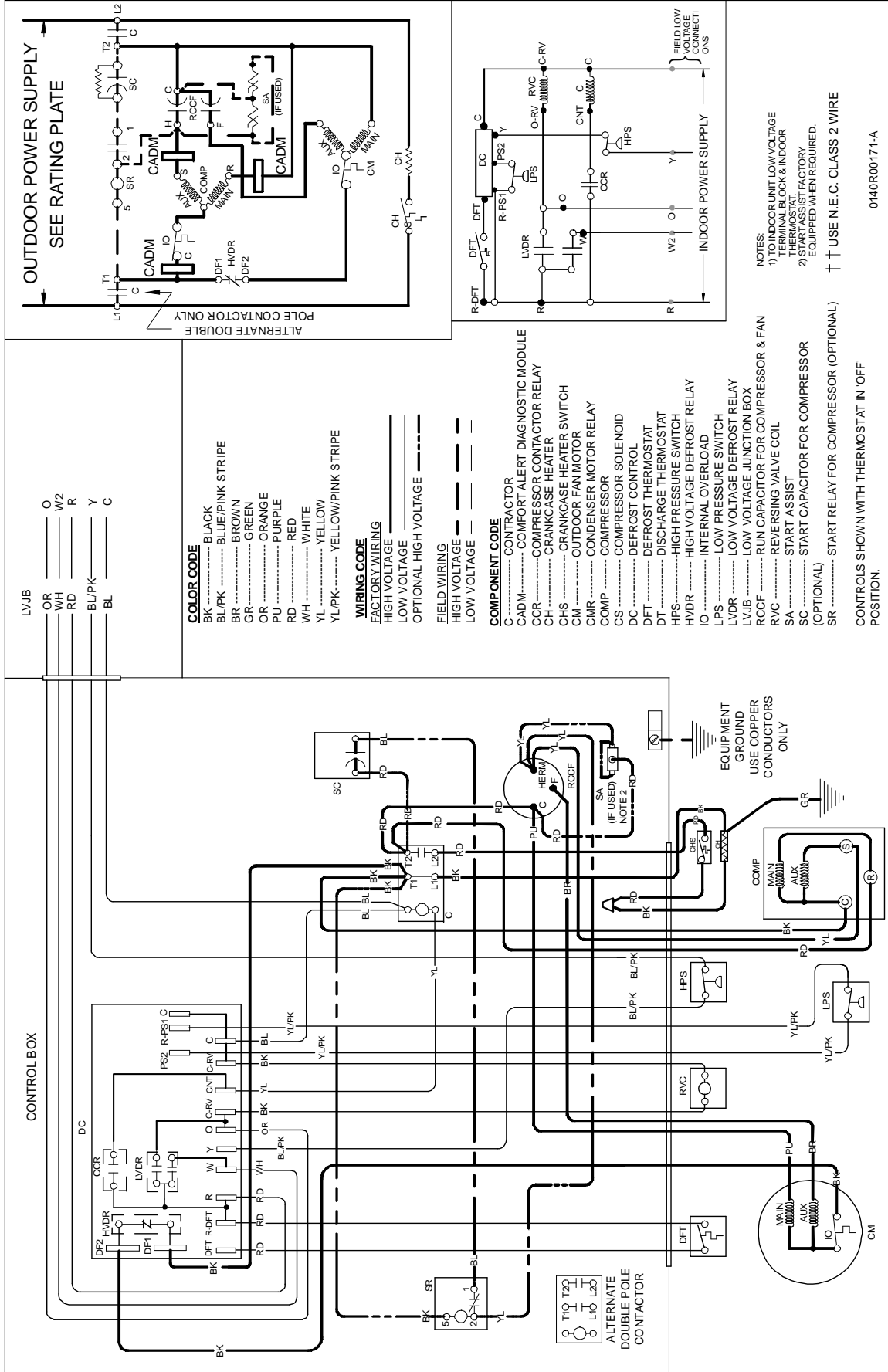

Wiring is subject to change. Always refer to the wiring diagram on the unit for the most up-to-date wiring.



**WARNING**  
**HIGH VOLTAGE!**  
 DISCONNECT ALL POWER BEFORE SERVICING OR INSTALLING THIS UNIT. MULTIPLE POWER SOURCES MAY BE PRESENT. FAILURE TO DO SO MAY CAUSE PROPERTY DAMAGE, PERSONAL INJURY OR DEATH.

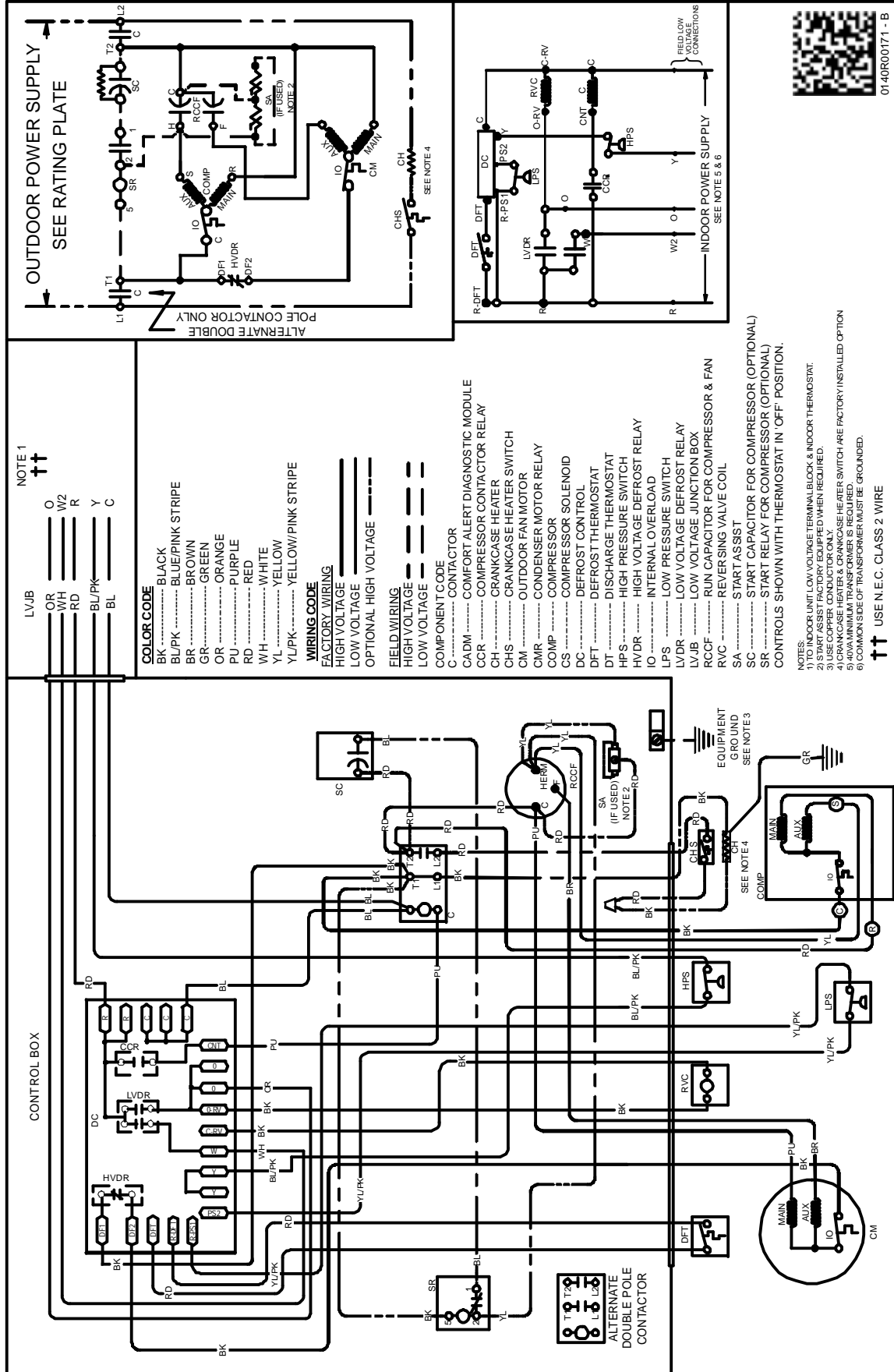

0140R00171 - B

Wiring is subject to change. Always refer to the wiring diagram on the unit for the most up-to-date wiring.



**WARNING**  
**HIGH VOLTAGE!**  
 DISCONNECT ALL POWER BEFORE SERVICING OR INSTALLING THIS UNIT. MULTIPLE POWER SOURCES MAY BE PRESENT. FAILURE TO DO SO MAY CAUSE PROPERTY DAMAGE, PERSONAL INJURY OR DEATH.

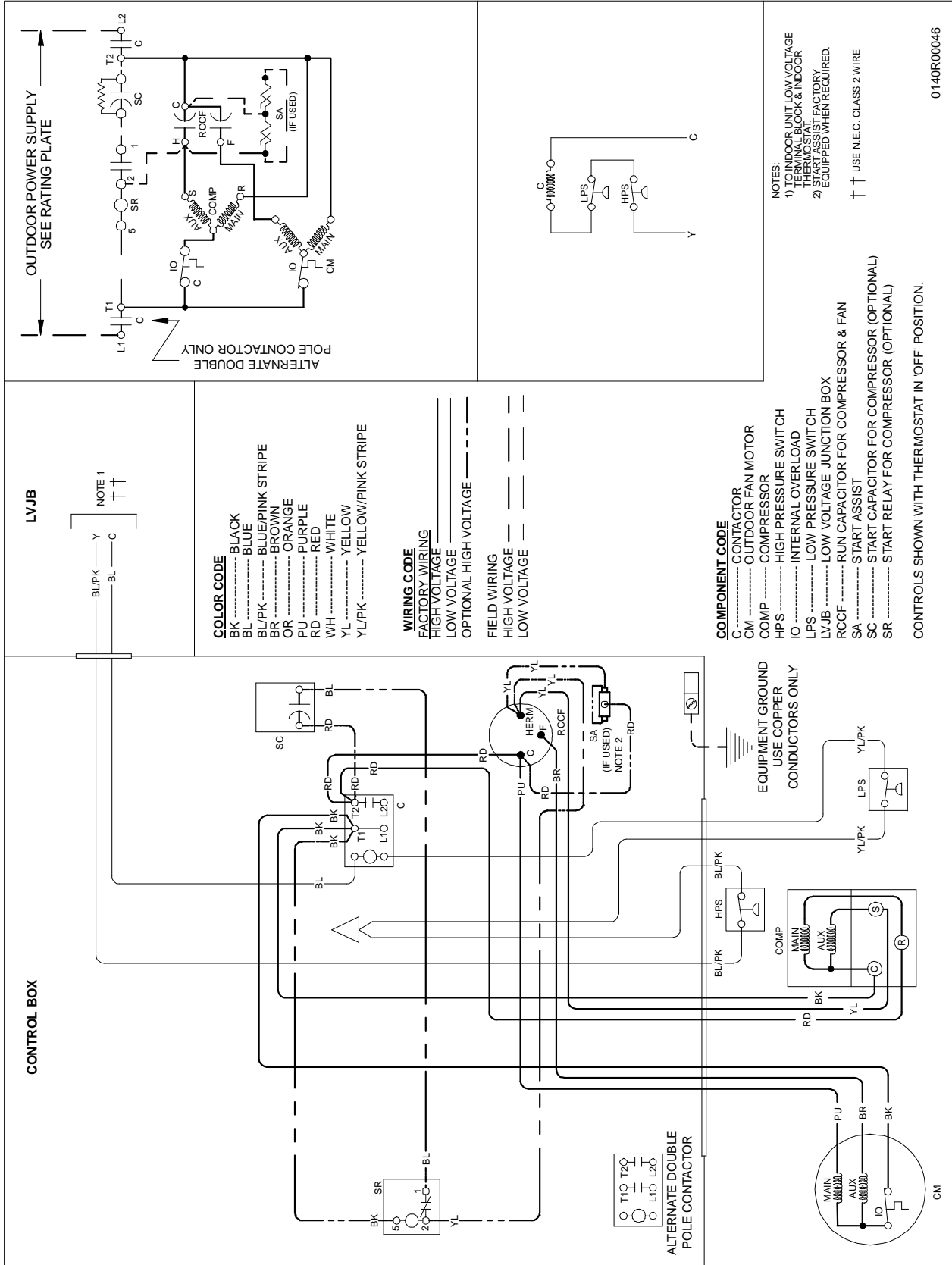

Wiring is subject to change. Always refer to the wiring diagram on the unit for the most up-to-date wiring.





# WIRING DIAGRAMS

# SSX160[24-48]1A\*/B\*; SSX160591AA



**WARNING**  
**HIGH VOLTAGE!**  
 DISCONNECT ALL POWER BEFORE SERVICING OR INSTALLING THIS UNIT. MULTIPLE POWER SOURCES MAY BE PRESENT. FAILURE TO DO SO MAY CAUSE PROPERTY DAMAGE, PERSONAL INJURY OR DEATH.

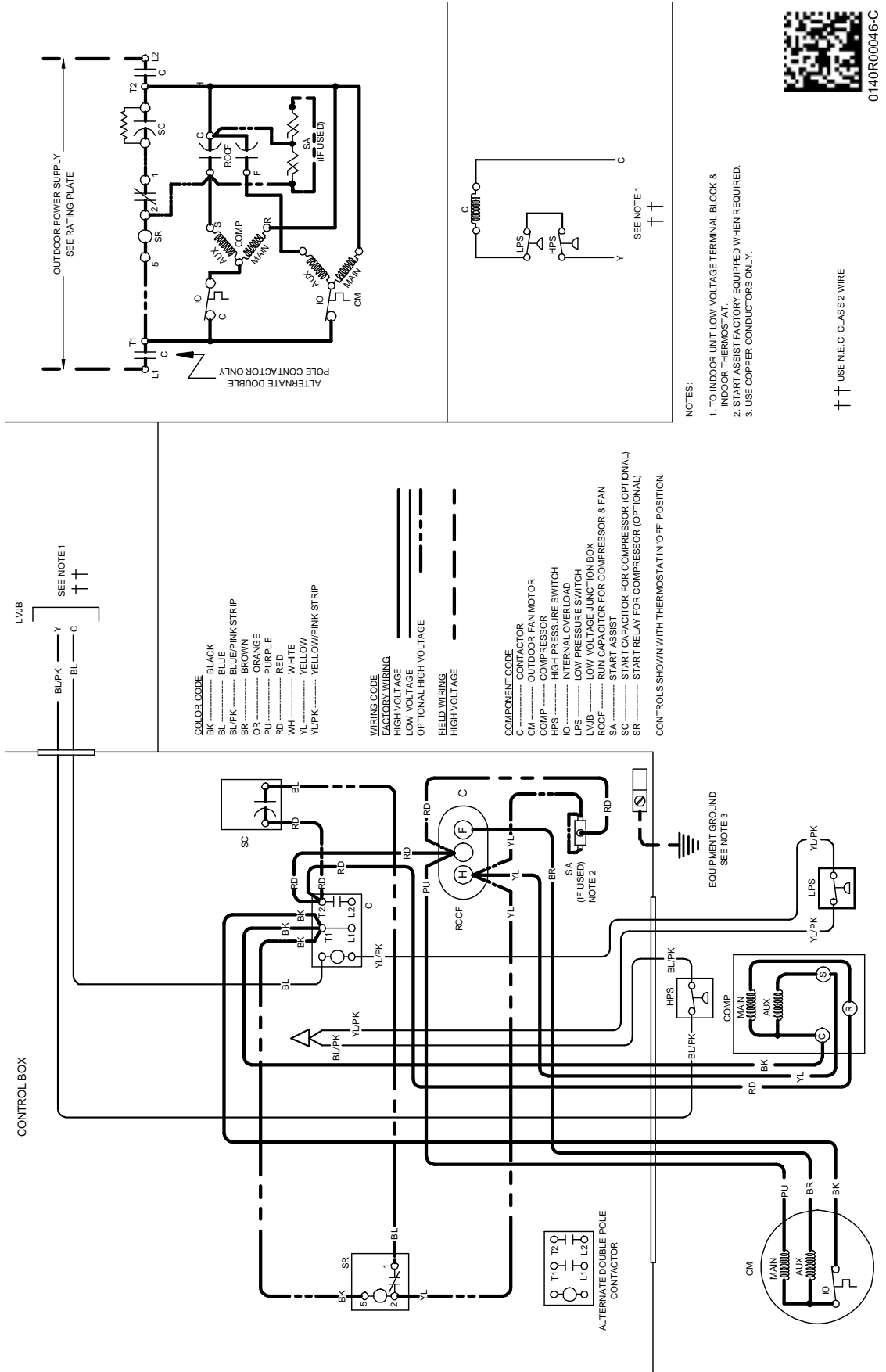

Wiring is subject to change. Always refer to the wiring diagram on the unit for the most up-to-date wiring.



**WARNING**  
**HIGH VOLTAGE!**  
 DISCONNECT ALL POWER BEFORE SERVICING OR INSTALLING THIS UNIT. MULTIPLE POWER SOURCES MAY BE PRESENT. FAILURE TO DO SO MAY CAUSE PROPERTY DAMAGE, PERSONAL INJURY OR DEATH.

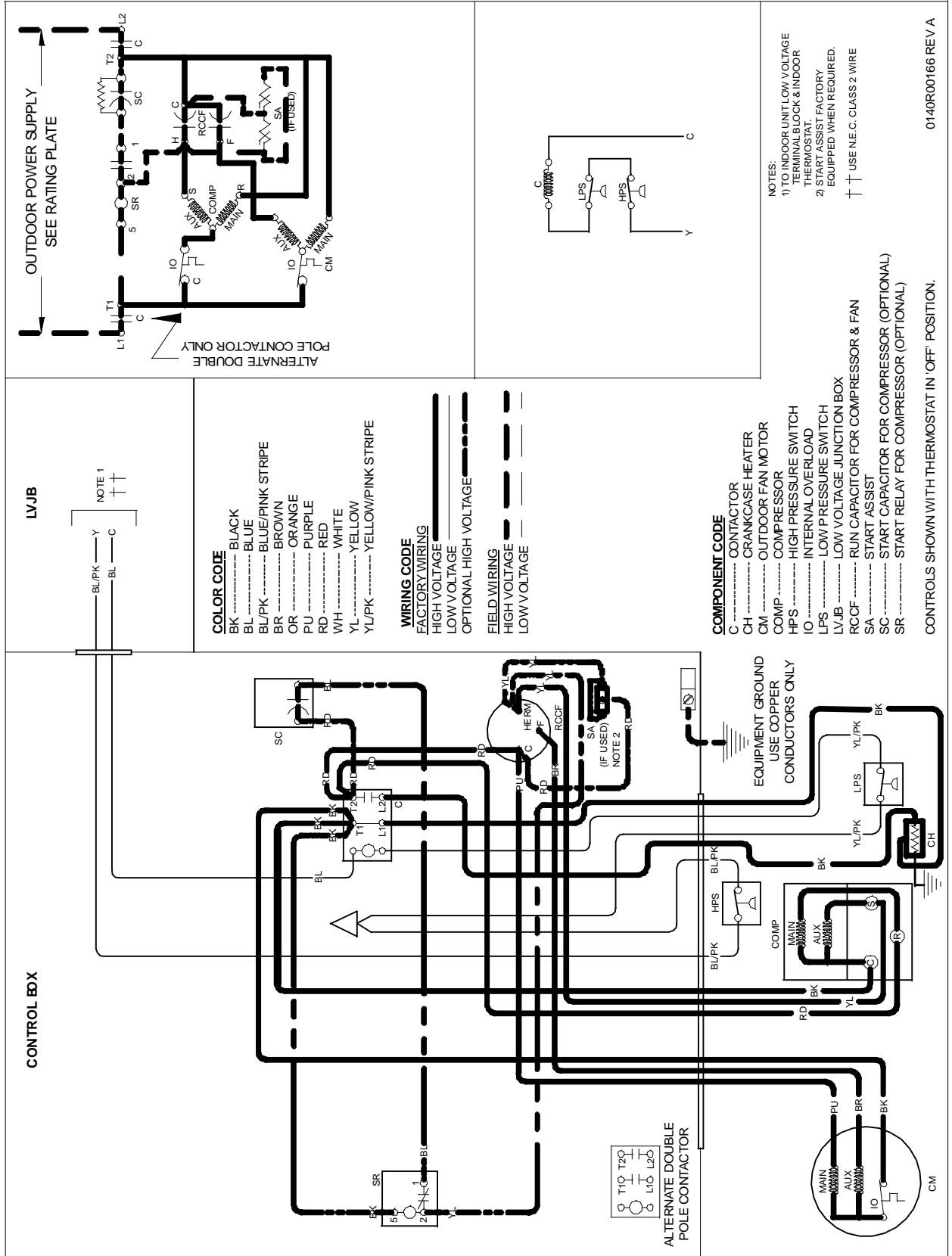

Wiring is subject to change. Always refer to the wiring diagram on the unit for the most up-to-date wiring.



**WARNING**  
**HIGH VOLTAGE!**  
 DISCONNECT ALL POWER BEFORE SERVICING OR INSTALLING THIS UNIT. MULTIPLE POWER SOURCES MAY BE PRESENT. FAILURE TO DO SO MAY CAUSE PROPERTY DAMAGE, PERSONAL INJURY OR DEATH.

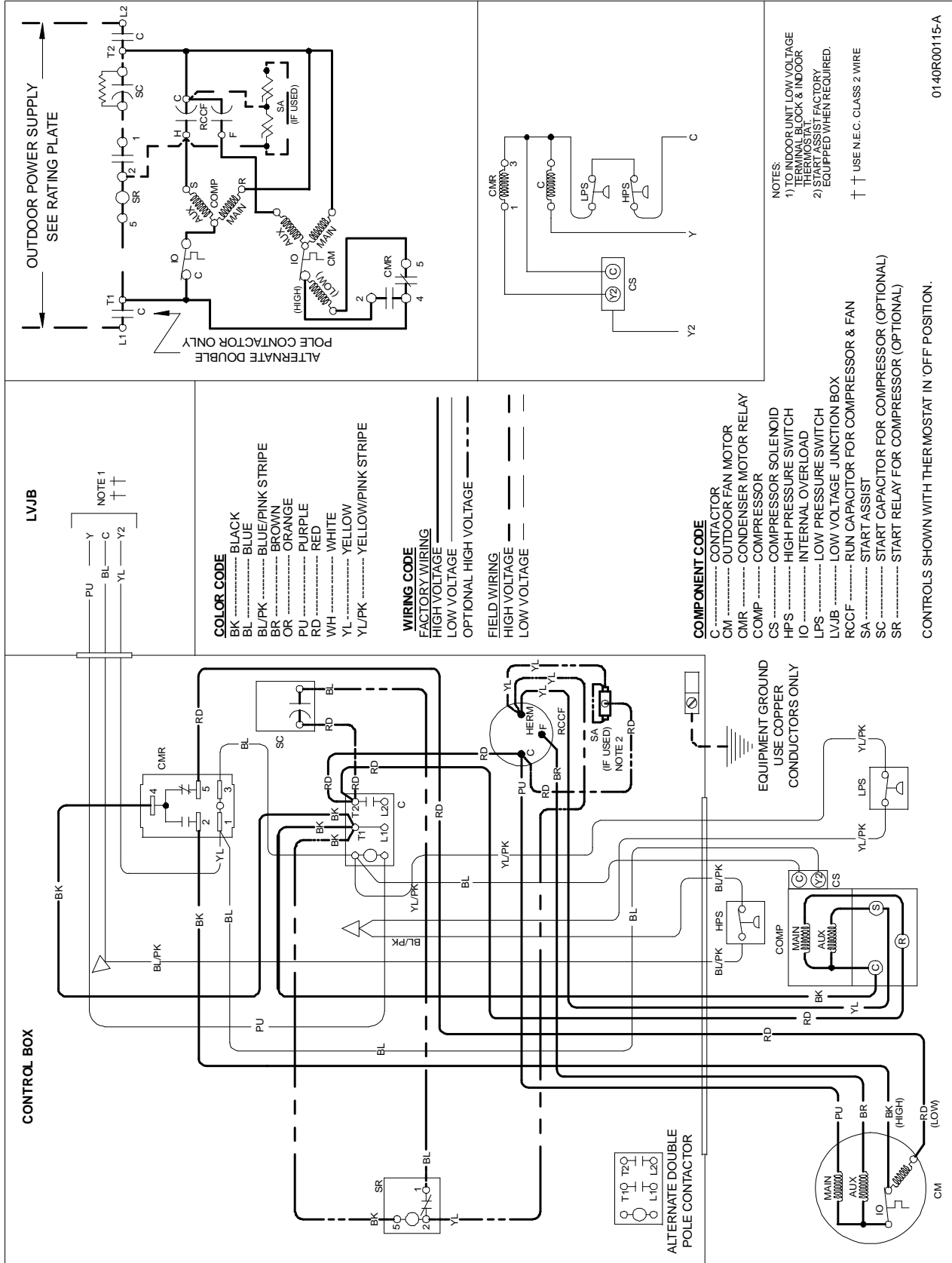

Wiring is subject to change. Always refer to the wiring diagram on the unit for the most up-to-date wiring.



# WIRING DIAGRAMS

SSZ140[18,30,42-60]1AF, 241AJ, 361AH  
SSZ140361B\*



**WARNING**  
HIGH VOLTAGE!  
DISCONNECT ALL POWER BEFORE SERVICING OR INSTALLING THIS UNIT. MULTIPLE POWER SOURCES MAY BE PRESENT. FAILURE TO DO SO MAY CAUSE PROPERTY DAMAGE, PERSONAL INJURY OR DEATH.

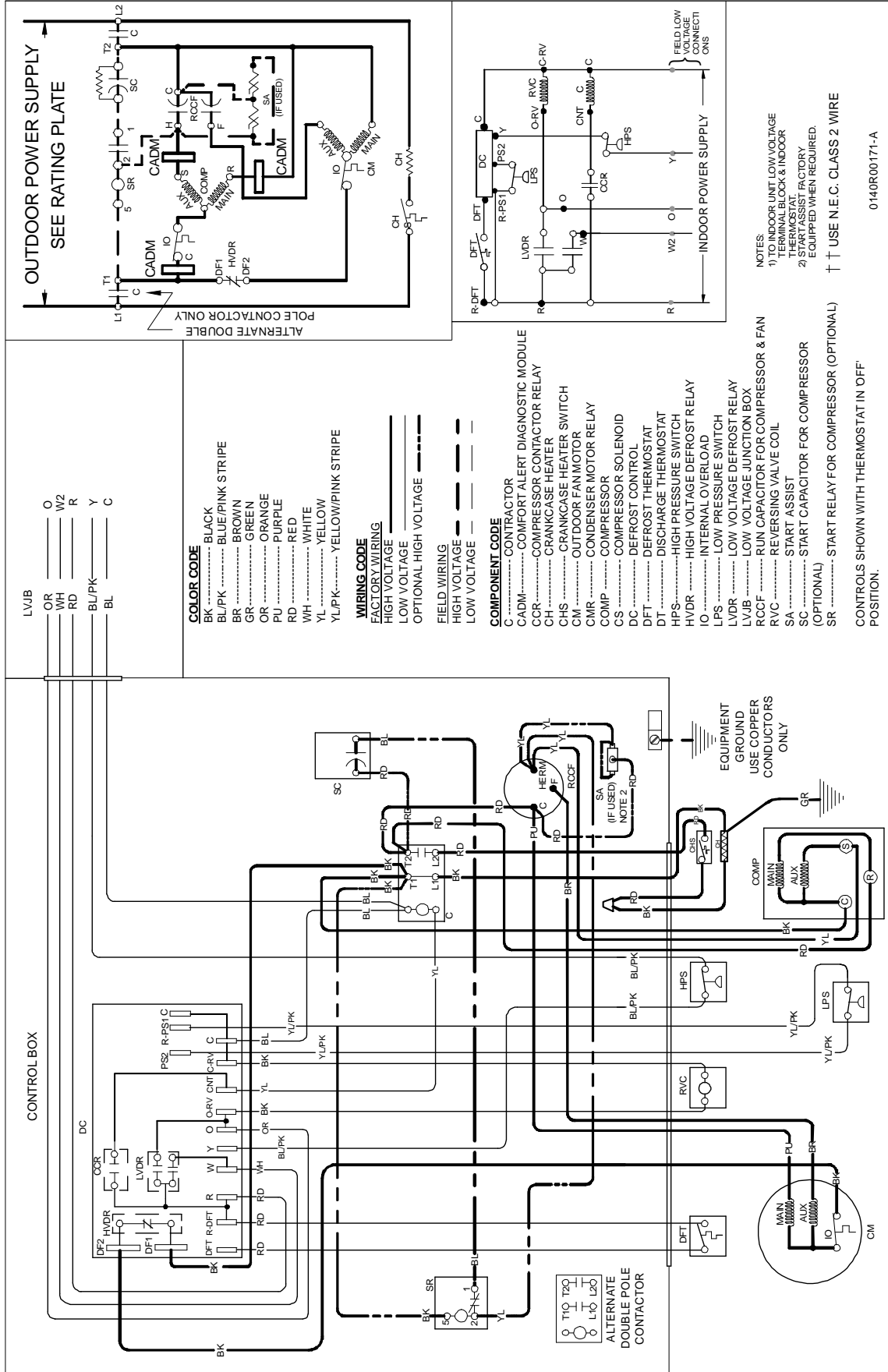

Wiring is subject to change. Always refer to the wiring diagram on the unit for the most up-to-date wiring.

# WIRING DIAGRAMS

SSZ140381AA, SSZ140[18,30,42-60]1AG, 241AK, 361AH  
SSZ140[18-36]1B\*



**HIGH VOLTAGE!**  
DISCONNECT ALL POWER BEFORE SERVICING OR INSTALLING THIS UNIT. MULTIPLE POWER SOURCES MAY BE PRESENT. FAILURE TO DO SO MAY CAUSE PROPERTY DAMAGE, PERSONAL INJURY OR DEATH.



**WARNING**

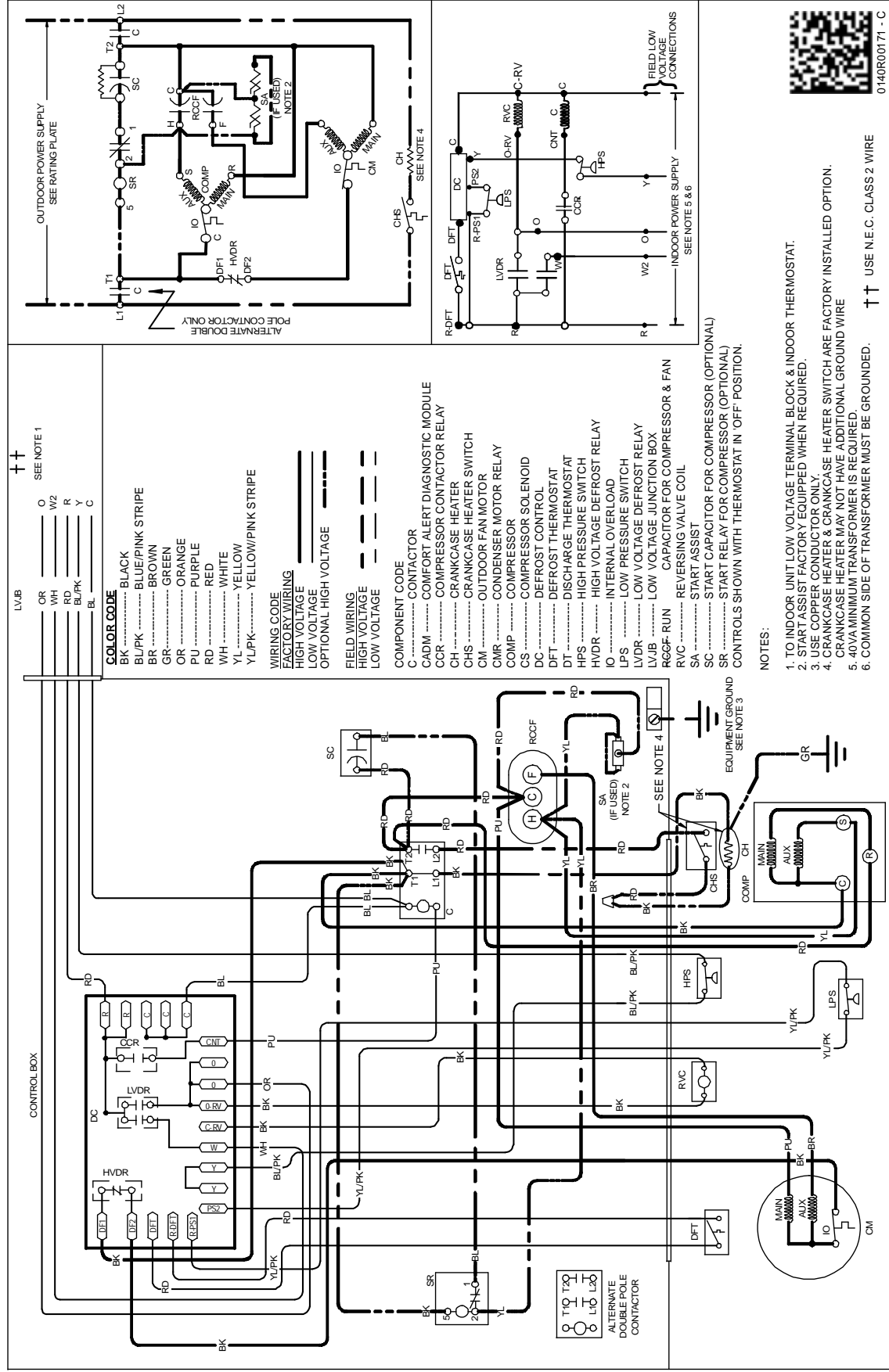

0140R00171 - C

Wiring is subject to change. Always refer to the wiring diagram on the unit for the most up-to-date wiring.



**WARNING**  
HIGH VOLTAGE!  
DISCONNECT ALL POWER BEFORE SERVICING OR INSTALLING THIS UNIT. MULTIPLE POWER SOURCES MAY BE PRESENT. FAILURE TO DO SO MAY CAUSE PROPERTY DAMAGE, PERSONAL INJURY OR DEATH.

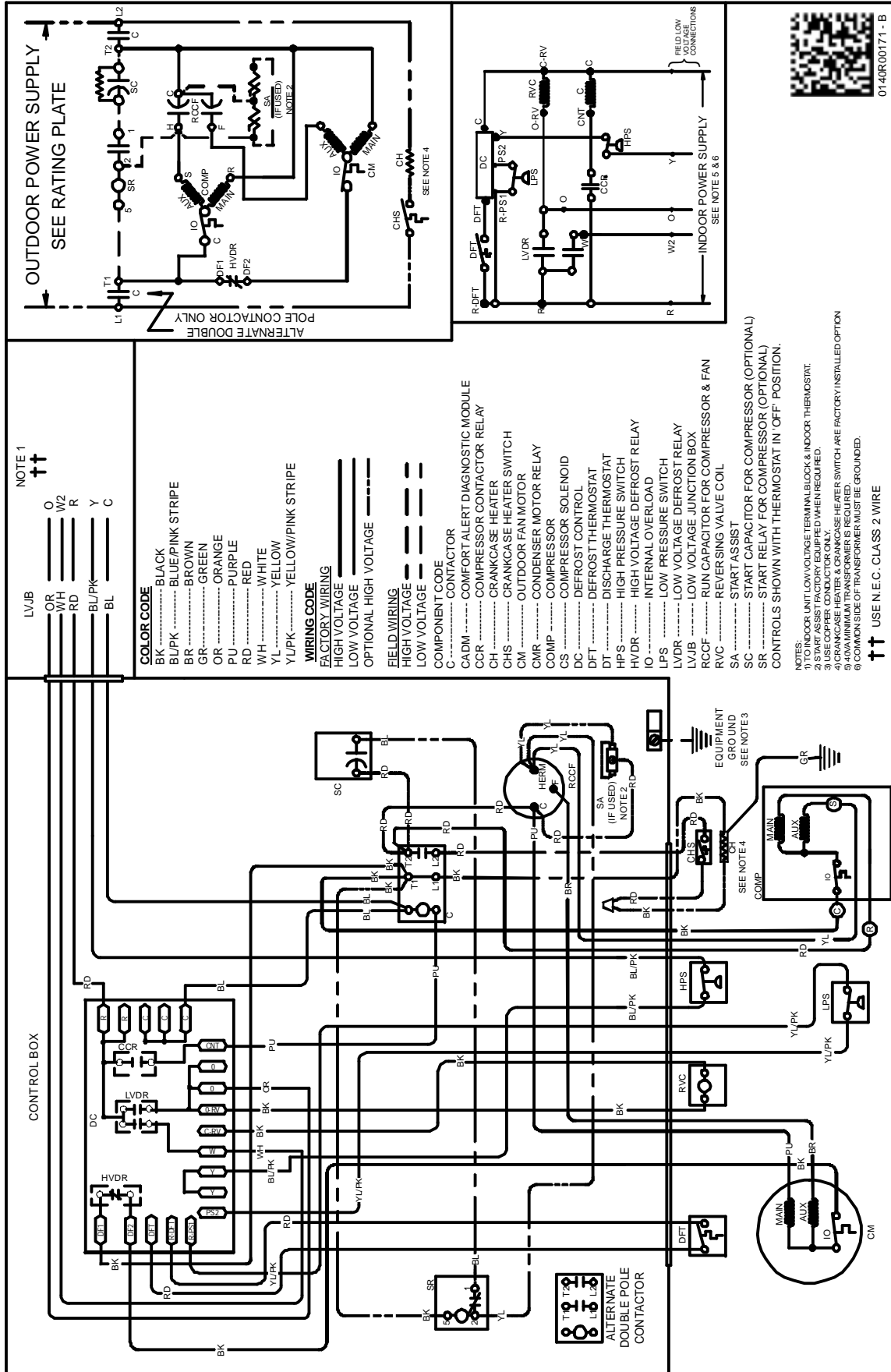

OUTDOOR POWER SUPPLY  
SEE RATING PLATE

ALTERNATE DOUBLE POLE CONTACTOR ONLY



0140R00171 - B

Wiring is subject to change. Always refer to the wiring diagram on the unit for the most up-to-date wiring.



# WIRING DIAGRAMS

# SSZ160[24]1AA-AF; SSZ160[36-48]1AA-AD

**WARNING**

**HIGH VOLTAGE!**  
DISCONNECT ALL POWER BEFORE SERVICING OR INSTALLING THIS UNIT. MULTIPLE POWER SOURCES MAY BE PRESENT. FAILURE TO DO SO MAY CAUSE PROPERTY DAMAGE, PERSONAL INJURY OR DEATH.

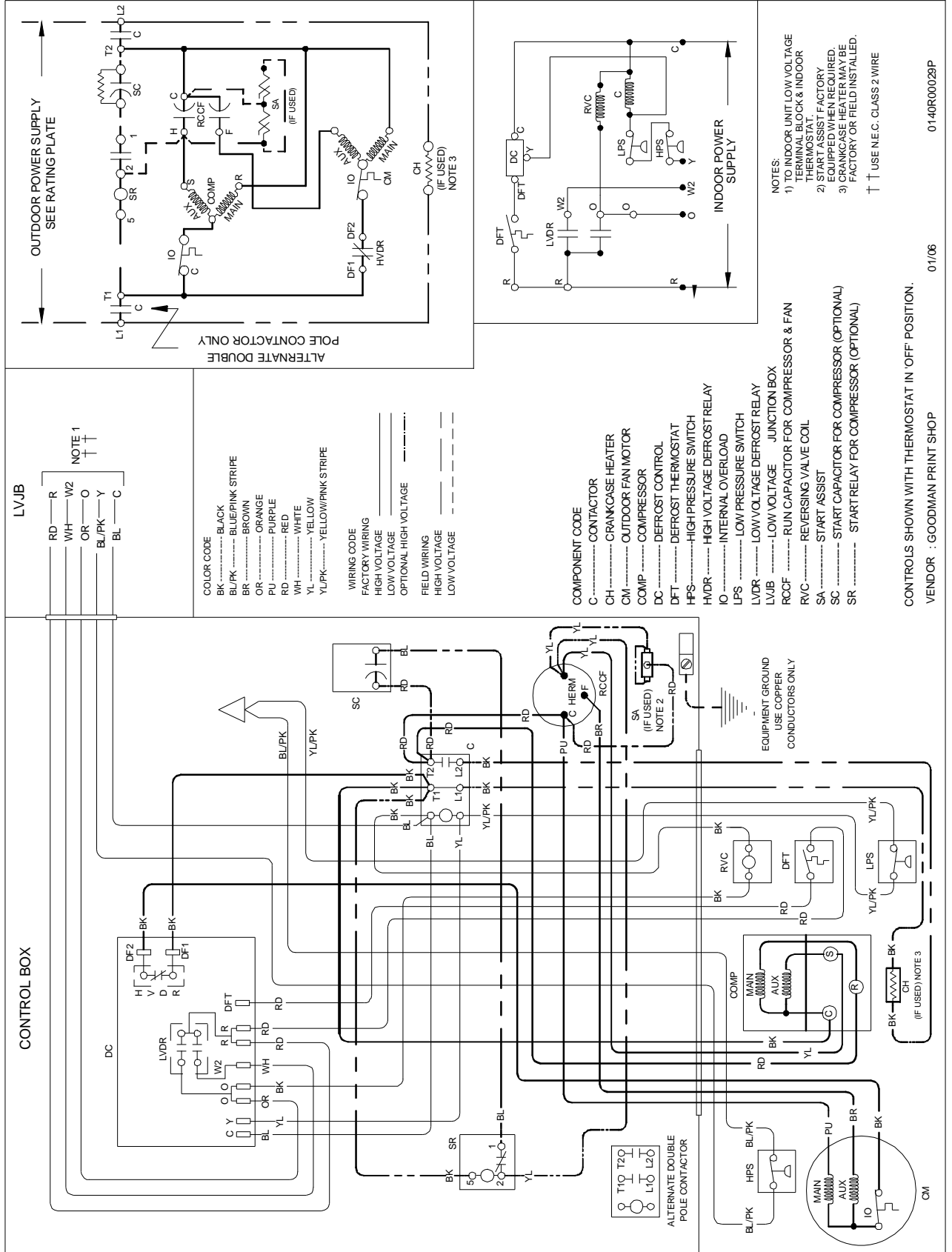

LV, JB

|       |    |
|-------|----|
| RD    | R  |
| WH    | W2 |
| OR    | O  |
| BL/PK | Y  |
| BL    | C  |

NOTE 1

COLOR CODE

- BK ..... BLACK
- BL/PK ..... BLUE/PINK STRIPE
- BR ..... BROWN
- OR ..... ORANGE
- PU ..... PURPLE
- RD ..... RED
- WH ..... WHITE
- YL ..... YELLOW
- YL/PK ..... YELLOW/PINK STRIPE

WIRING CODE

- SOLID LINE ..... FACTORY WIRING
- DASHED LINE ..... HIGH VOLTAGE
- DOTTED LINE ..... LOW VOLTAGE
- DASH-DOTTED LINE ..... OPTIONAL HIGH VOLTAGE

FIELD WIRING

- SOLID LINE ..... HIGH VOLTAGE
- DASHED LINE ..... LOW VOLTAGE

COMPONENT CODE

- C ..... CONTACTOR
- CH ..... CRANKCASE HEATER
- CM ..... OUTDOOR FAN MOTOR
- COMP ..... COMPRESSOR
- DC ..... DEFROST CONTROL
- DF1 ..... DEFROST THERMOSTAT
- HPS ..... HIGH PRESSURE SWITCH
- HVDR ..... HIGH VOLTAGE DEFROST RELAY
- IO ..... INTERNAL OVERLOAD
- LPS ..... LOW PRESSURE SWITCH
- LVDR ..... LOW VOLTAGE DEFROST RELAY
- LVJB ..... LOW VOLTAGE JUNCTION BOX
- RCCF ..... RUN CAPACITOR FOR COMPRESSOR & FAN
- RVC ..... REVERSING VALVE COIL
- SA ..... START ASSIST
- SC ..... START CAPACITOR FOR COMPRESSOR (OPTIONAL)
- SR ..... START RELAY FOR COMPRESSOR (OPTIONAL)

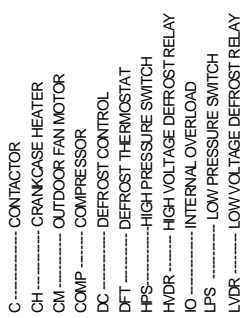

NOTES:

- TO INDOOR UNIT LOW VOLTAGE TERMINAL BLOCK & INDOOR THERMOSTAT.
- START ASSIST FACTORY EQUIPPED WHEN REQUIRED.
- CRANKCASE HEATER MAY BE FACTORY OR FIELD INSTALLED.

†† USE N.E.C. CLASS 2 WIRE

CONTROLS SHOWN WITH THERMOSTAT IN OFF POSITION.

VENDOR : GOODMAN PRINT SHOP

01/06

0140R00029P



**WARNING**  
HIGH VOLTAGE!  
DISCONNECT ALL POWER BEFORE SERVICING OR INSTALLING THIS UNIT. MULTIPLE POWER SOURCES MAY BE PRESENT. FAILURE TO DO SO MAY CAUSE PROPERTY DAMAGE, PERSONAL INJURY OR DEATH.

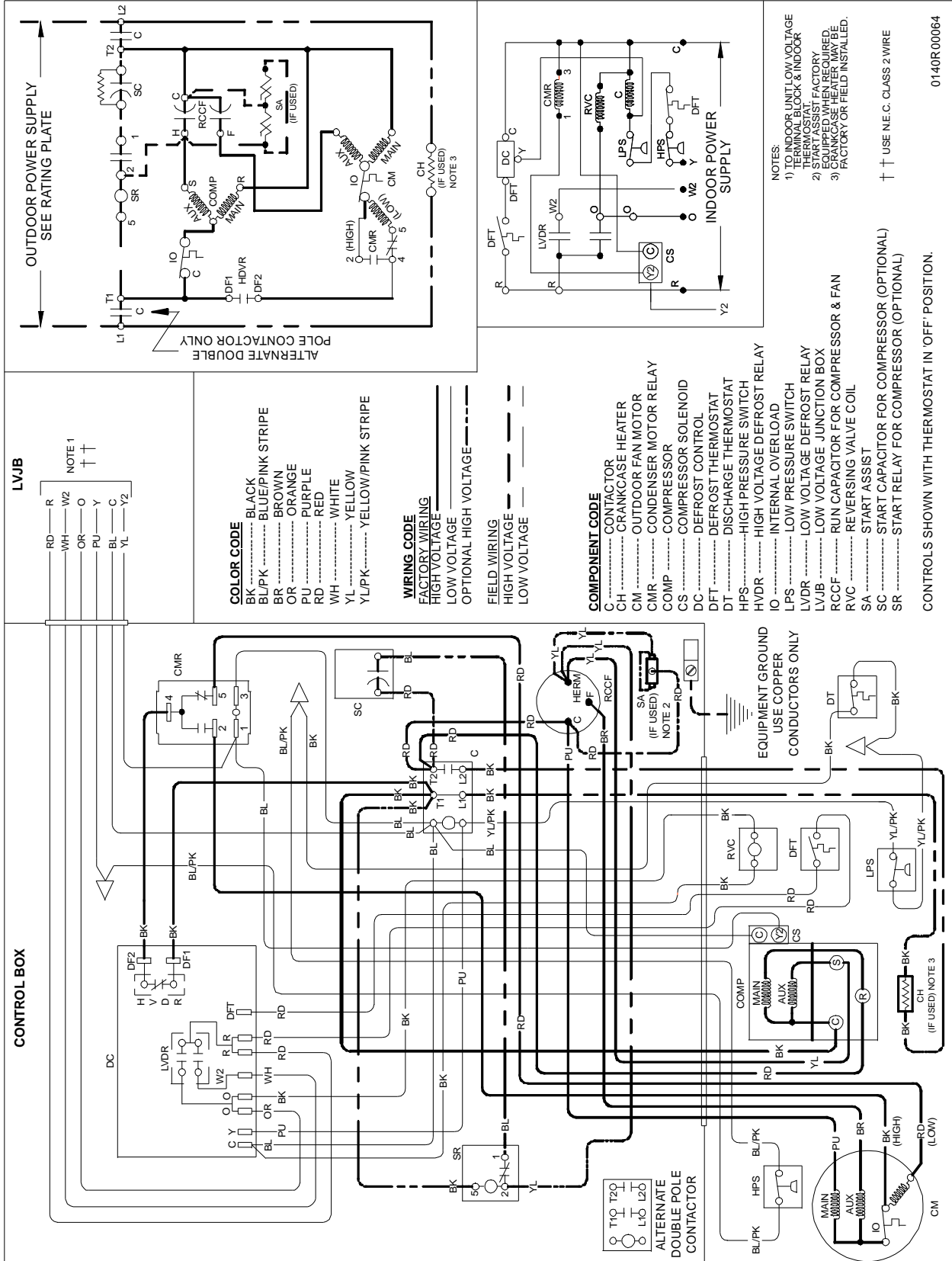

Wiring is subject to change. Always refer to the wiring diagram on the unit for the most up-to-date wiring.



**WARNING**  
 HIGH VOLTAGE!  
 DISCONNECT ALL POWER BEFORE SERVICING OR INSTALLING THIS UNIT. MULTIPLE POWER SOURCES MAY BE PRESENT. FAILURE TO DO SO MAY CAUSE PROPERTY DAMAGE, PERSONAL INJURY OR DEATH.

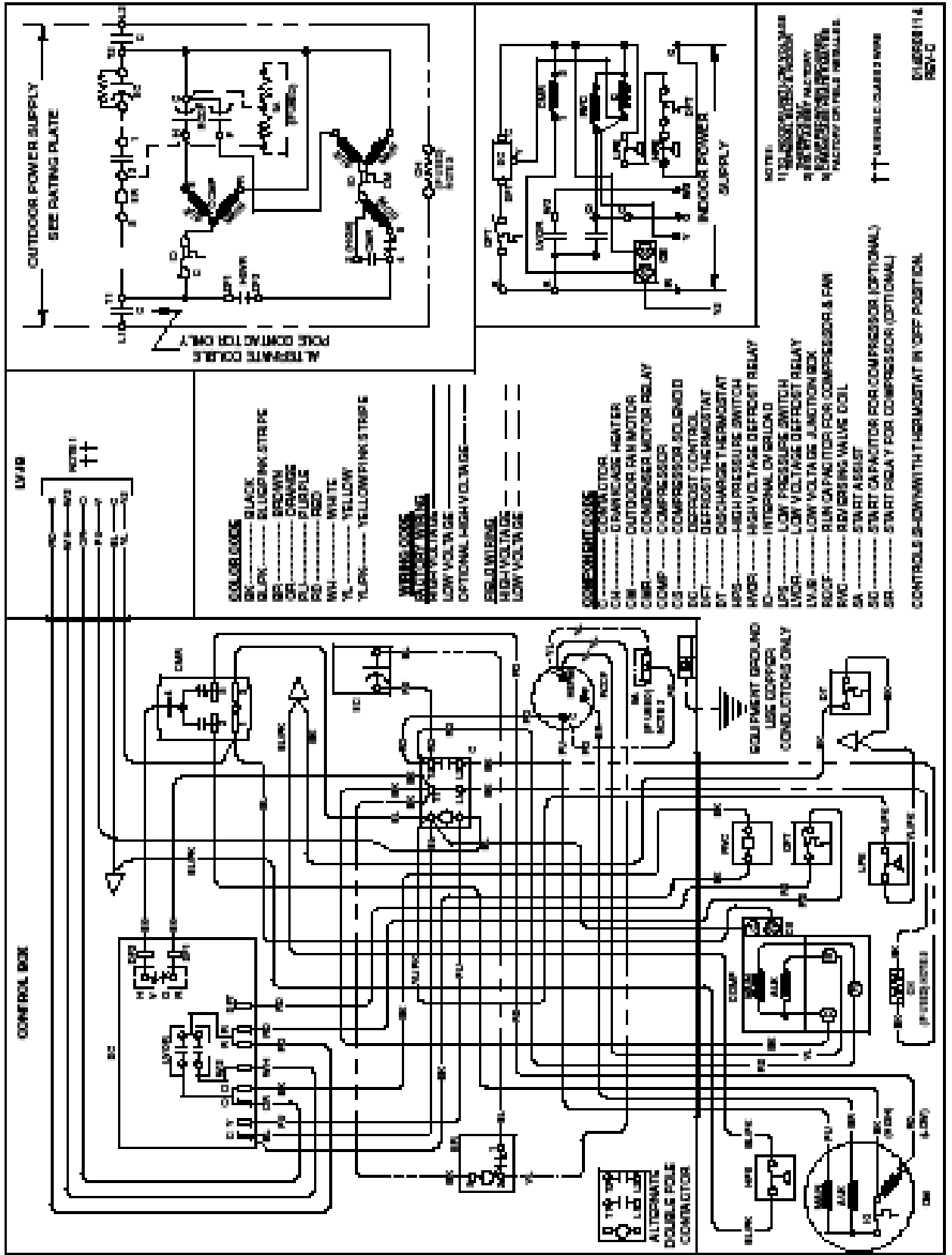

Wiring is subject to change. Always refer to the wiring diagram on the unit for the most up-to-date wiring.



**WARNING**  
**HIGH VOLTAGE!**  
 DISCONNECT ALL POWER BEFORE SERVICING OR INSTALLING THIS UNIT. MULTIPLE POWER SOURCES MAY BE PRESENT. FAILURE TO DO SO MAY CAUSE PROPERTY DAMAGE, PERSONAL INJURY OR DEATH.

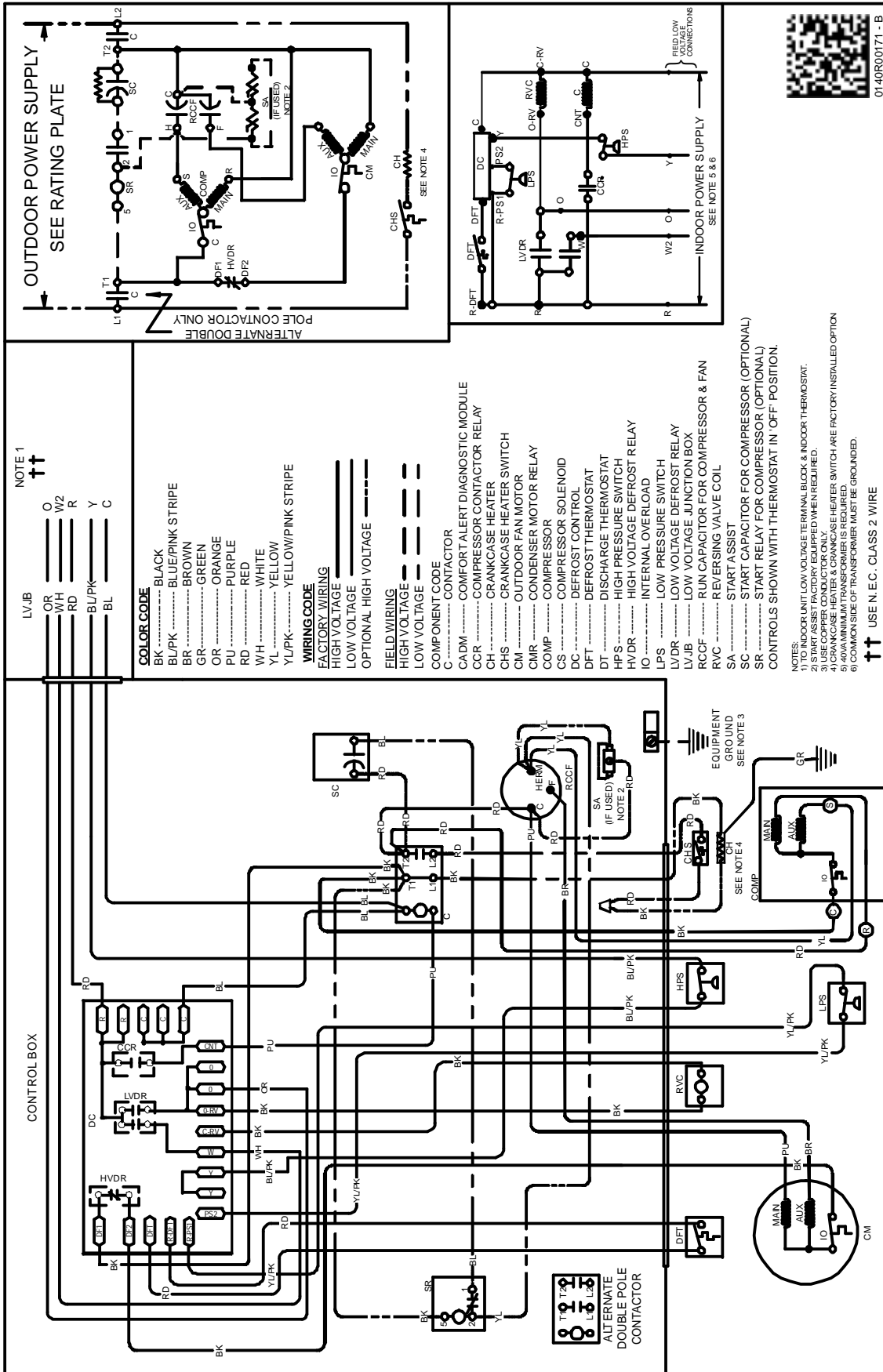

0140R00171 - B

Wiring is subject to change. Always refer to the wiring diagram on the unit for the most up-to-date wiring.



**WARNING**  
**HIGH VOLTAGE!**  
 DISCONNECT ALL POWER BEFORE SERVICING OR INSTALLING THIS UNIT. MULTIPLE POWER SOURCES MAY BE PRESENT. FAILURE TO DO SO MAY CAUSE PROPERTY DAMAGE, PERSONAL INJURY OR DEATH.

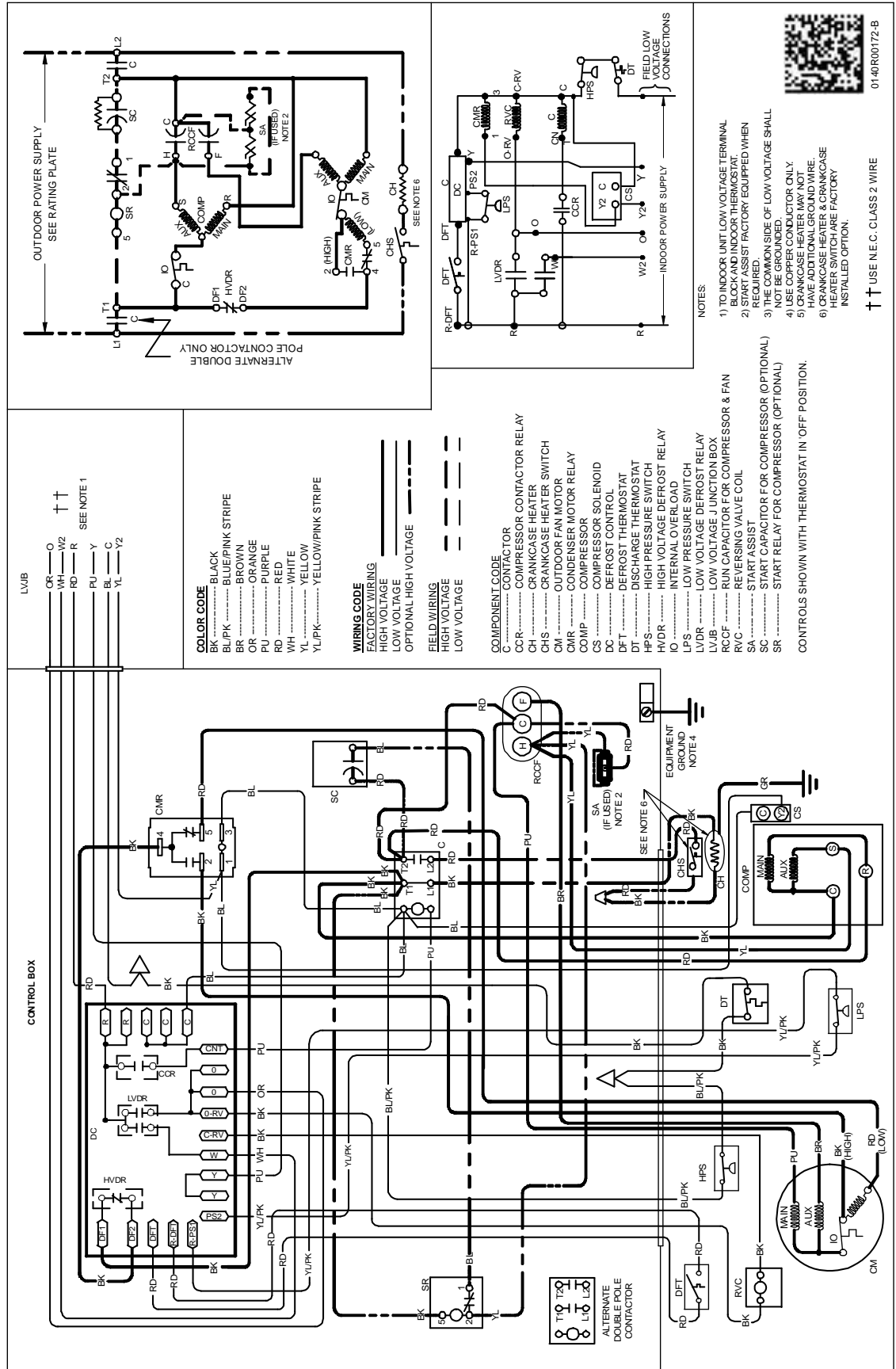

Wiring is subject to change. Always refer to the wiring diagram on the unit for the most up-to-date wiring.

# WIRING DIAGRAMS

VSX130[18-48/61]1A\* / VSX130[24/36/42-60]1B\*/1D\*  
VSX130[30]1D\*/VSX130[36]1E\*

**WARNING**

HIGH VOLTAGE!  
DISCONNECT ALL POWER BEFORE SERVICING OR INSTALLING THIS UNIT. MULTIPLE POWER SOURCES MAY BE PRESENT. FAILURE TO DO SO MAY CAUSE PROPERTY DAMAGE, PERSONAL INJURY OR DEATH.

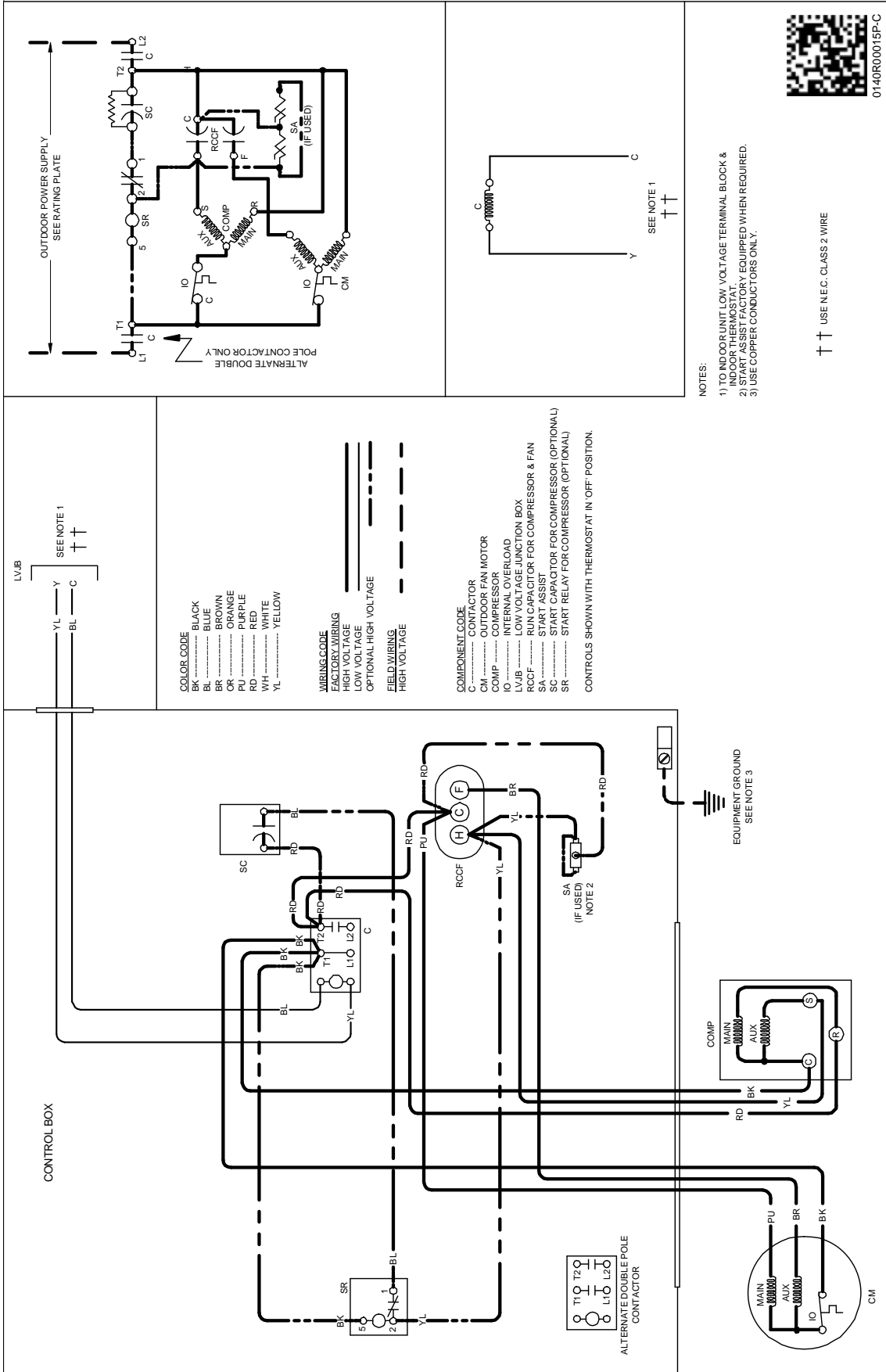

Wiring is subject to change. Always refer to the wiring diagram on the unit for the most up-to-date wiring.

# WIRING DIAGRAMS

VSX130[18-48/61]1A\* / VSX130[24/36/42-60]1B\*/1D\*  
VSX130[30]1D\*/VSX130[36]1E\*



**WARNING**  
HIGH VOLTAGE!  
DISCONNECT ALL POWER BEFORE SERVICING OR INSTALLING THIS UNIT. MULTIPLE POWER SOURCES MAY BE PRESENT. FAILURE TO DO SO MAY CAUSE PROPERTY DAMAGE, PERSONAL INJURY OR DEATH.

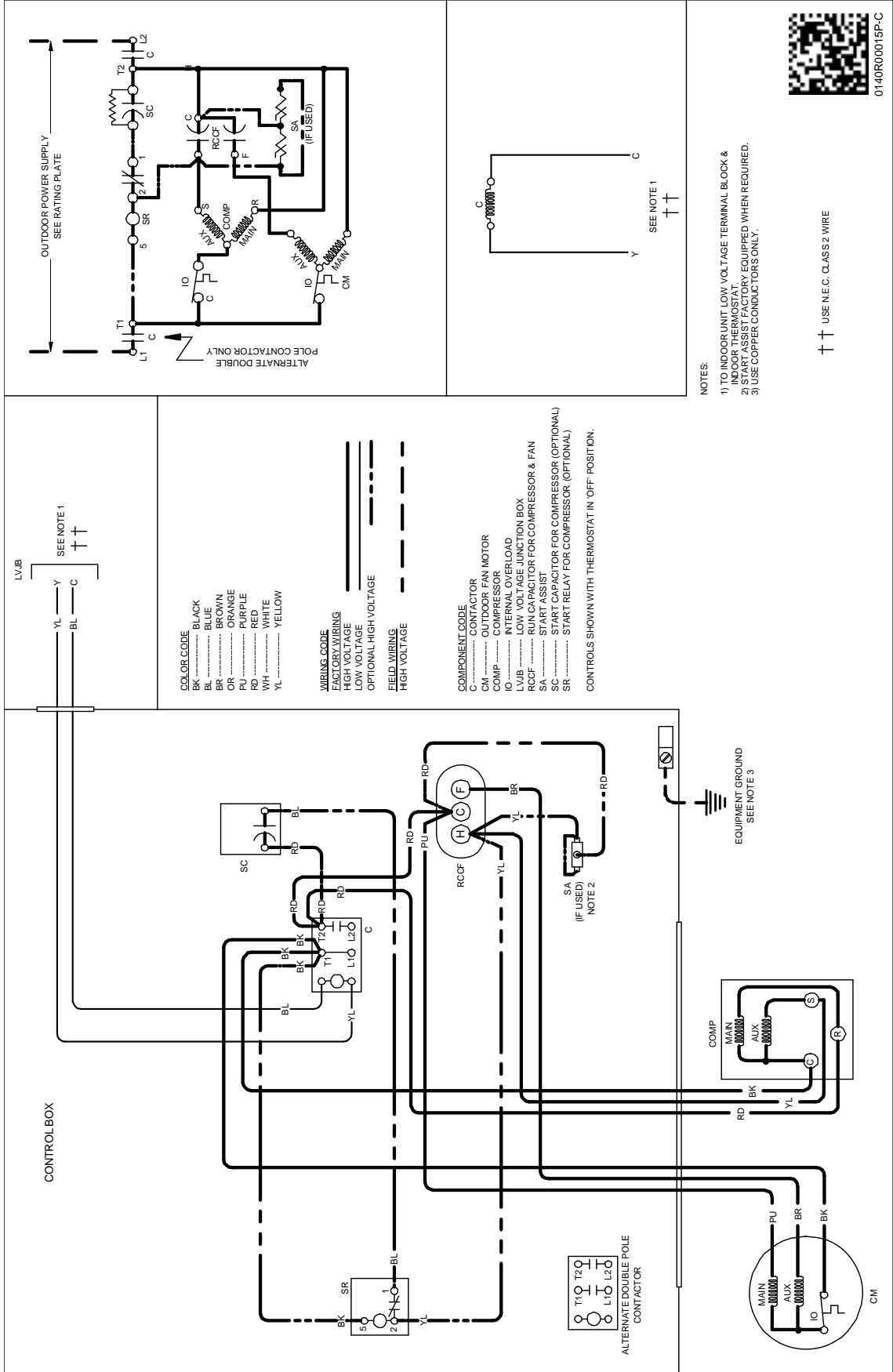

0140R0001SP-C

NOTES:  
1) TO INDOOR UNIT, LOW VOLTAGE TERMINAL BLOCK & INDOOR THERMOSTAT.  
2) START ASSIST FACTORY EQUIPPED WHEN REQUIRED.  
3) USE COPPER CONDUCTORS ONLY.

++ USE N.E.C. CLASS 2 WIRE

SEE NOTE 1  
++

Wiring is subject to change. Always refer to the wiring diagram on the unit for the most up-to-date wiring.



**WARNING**  
**HIGH VOLTAGE!**  
 DISCONNECT ALL POWER BEFORE SERVICING OR INSTALLING THIS UNIT. MULTIPLE POWER SOURCES MAY BE PRESENT. FAILURE TO DO SO MAY CAUSE PROPERTY DAMAGE, PERSONAL INJURY OR DEATH.

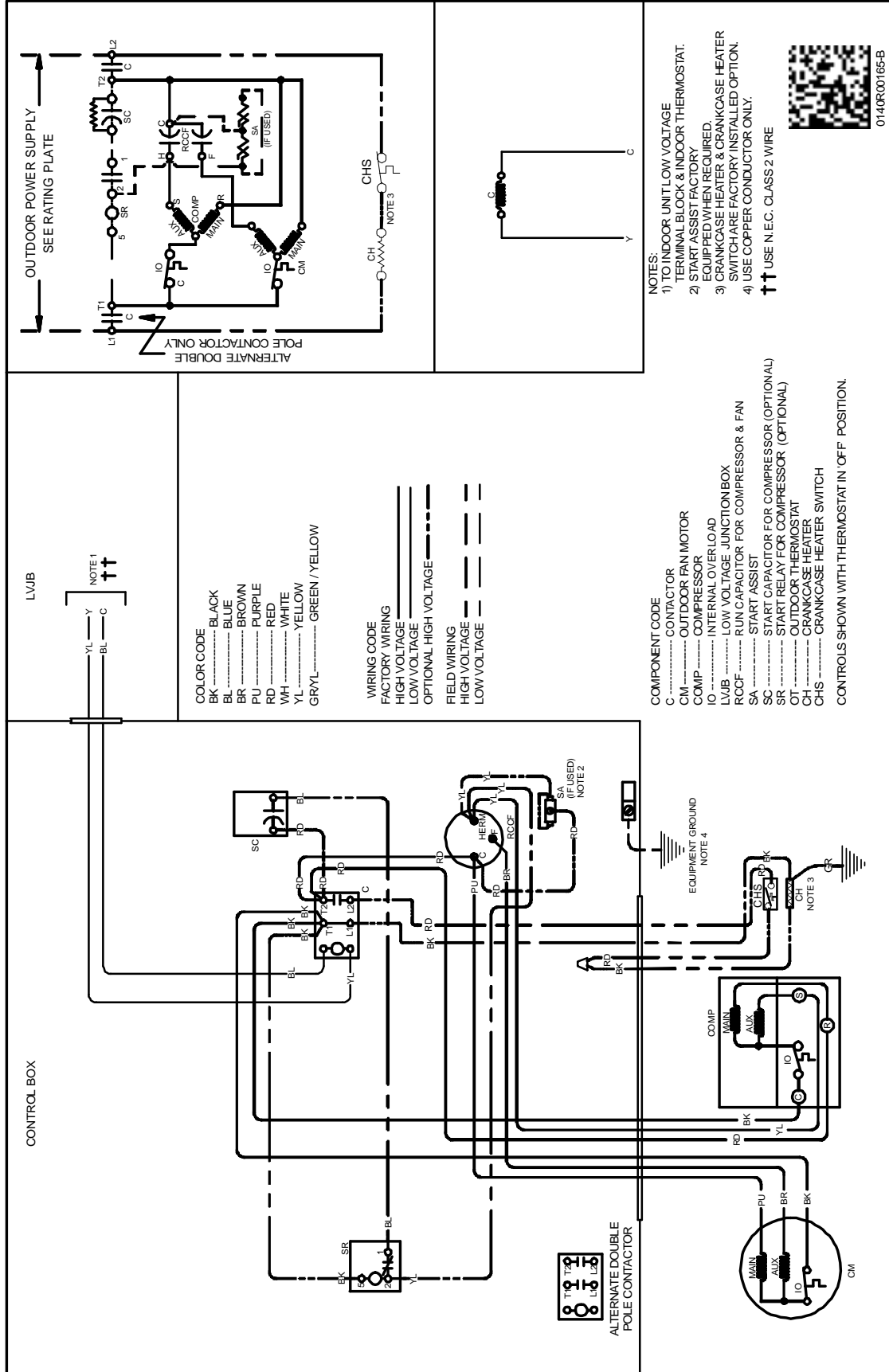

Wiring is subject to change. Always refer to the wiring diagram on the unit for the most up-to-date wiring.





**WARNING**  
**HIGH VOLTAGE!**  
 DISCONNECT ALL POWER BEFORE SERVICING OR INSTALLING THIS UNIT. MULTIPLE POWER SOURCES MAY BE PRESENT. FAILURE TO DO SO MAY CAUSE PROPERTY DAMAGE, PERSONAL INJURY OR DEATH.

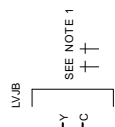
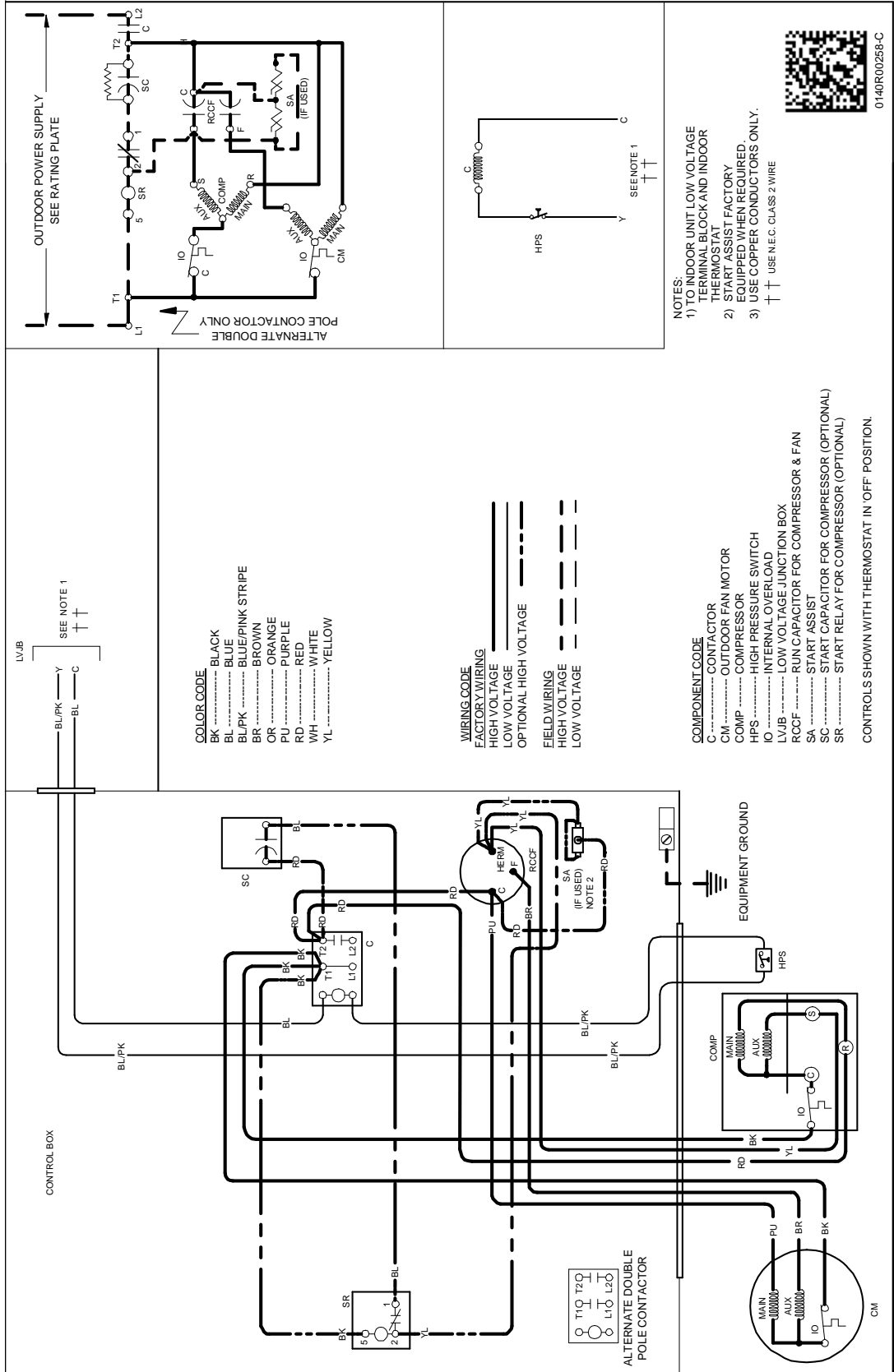

- COLOR CODE**
- BK ..... BLACK
  - BL ..... BLUE
  - BL/PK ..... BLUE/PINK STRIPE
  - BR ..... BROWN
  - OR ..... ORANGE
  - PU ..... PURPLE
  - RD ..... RED
  - WH ..... WHITE
  - YL ..... YELLOW

- WIRING CODE**
- FACTORY WIRING
  - HIGH VOLTAGE
  - LOW VOLTAGE
  - OPTIONAL HIGH VOLTAGE
  - FIELD WIRING
  - HIGH VOLTAGE
  - LOW VOLTAGE

- COMPONENT CODE**
- C ..... CONTACTOR
  - CM ..... OUTDOOR FAN MOTOR
  - COMP ..... COMPRESSOR
  - HPS ..... HIGH PRESSURE SWITCH
  - IO ..... INTERNAL OVERLOAD
  - LV, B, Y, C ..... LOW VOLTAGE JUNCTION BOX
  - RCCF ..... RUN CAPACITOR FOR COMPRESSOR & FAN
  - SA ..... START ASSIST
  - SR ..... START RELAY FOR COMPRESSOR (OPTIONAL)
  - SR ..... START RELAY FOR COMPRESSOR (OPTIONAL)

CONTROLS SHOWN WITH THERMOSTAT IN 'OFF' POSITION.

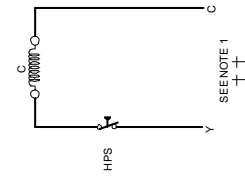
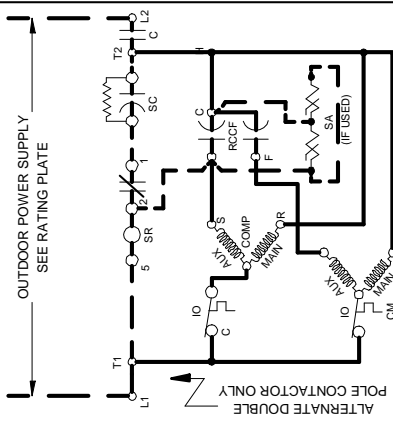

- NOTES:**
- 1) TO INDOOR UNIT LOW VOLTAGE TERMINAL BLOCK AND INDOOR THERMOSTAT
  - 2) START ASSIST FACTORY EQUIPPED WHEN REQUIRED.
  - 3) USE COPPER CONDUCTORS ONLY.
- ↑↑ USE N.E.C. CLASS 2 WIRE



0140R00265-C

Wiring is subject to change. Always refer to the wiring diagram on the unit for the most up-to-date wiring.



**WARNING**  
**HIGH VOLTAGE!**  
 DISCONNECT ALL POWER BEFORE SERVICING OR INSTALLING THIS UNIT. MULTIPLE POWER SOURCES MAY BE PRESENT. FAILURE TO DO SO MAY CAUSE PROPERTY DAMAGE, PERSONAL INJURY OR DEATH.

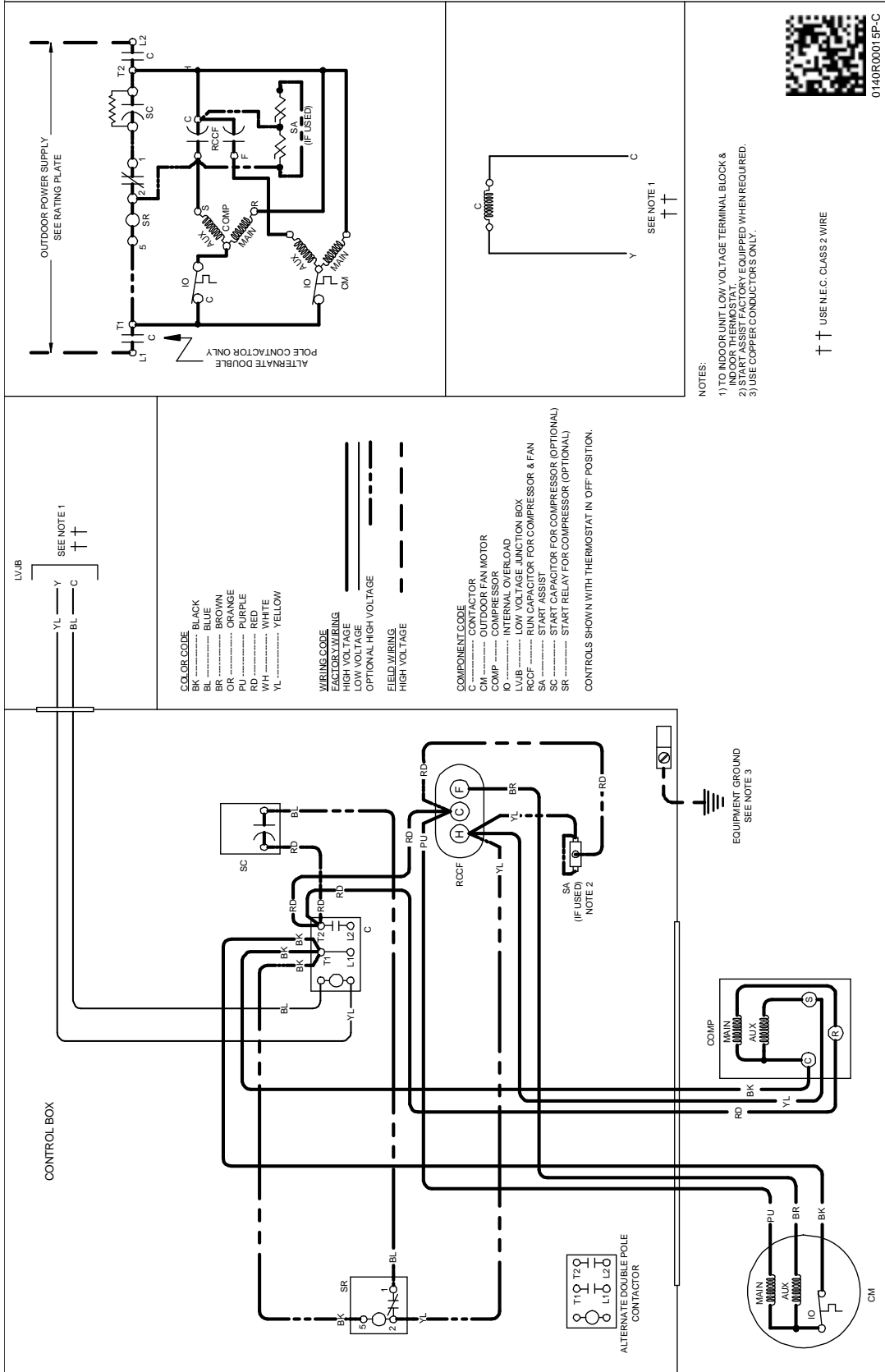

0140R00019P-C

Wiring is subject to change. Always refer to the wiring diagram on the unit for the most up-to-date wiring.



# WIRING DIAGRAMS

VSZ130181AB, VSZ130241BB, VSZ130301AC, VSZ130361BB  
VSZ130421A\*, VSZ130481AB, VSZ130601AB



**WARNING**  
HIGH VOLTAGE!  
DISCONNECT ALL POWER BEFORE SERVICING OR INSTALLING THIS UNIT. MULTIPLE POWER SOURCES MAY BE PRESENT. FAILURE TO DO SO MAY CAUSE PROPERTY DAMAGE, PERSONAL INJURY OR DEATH.

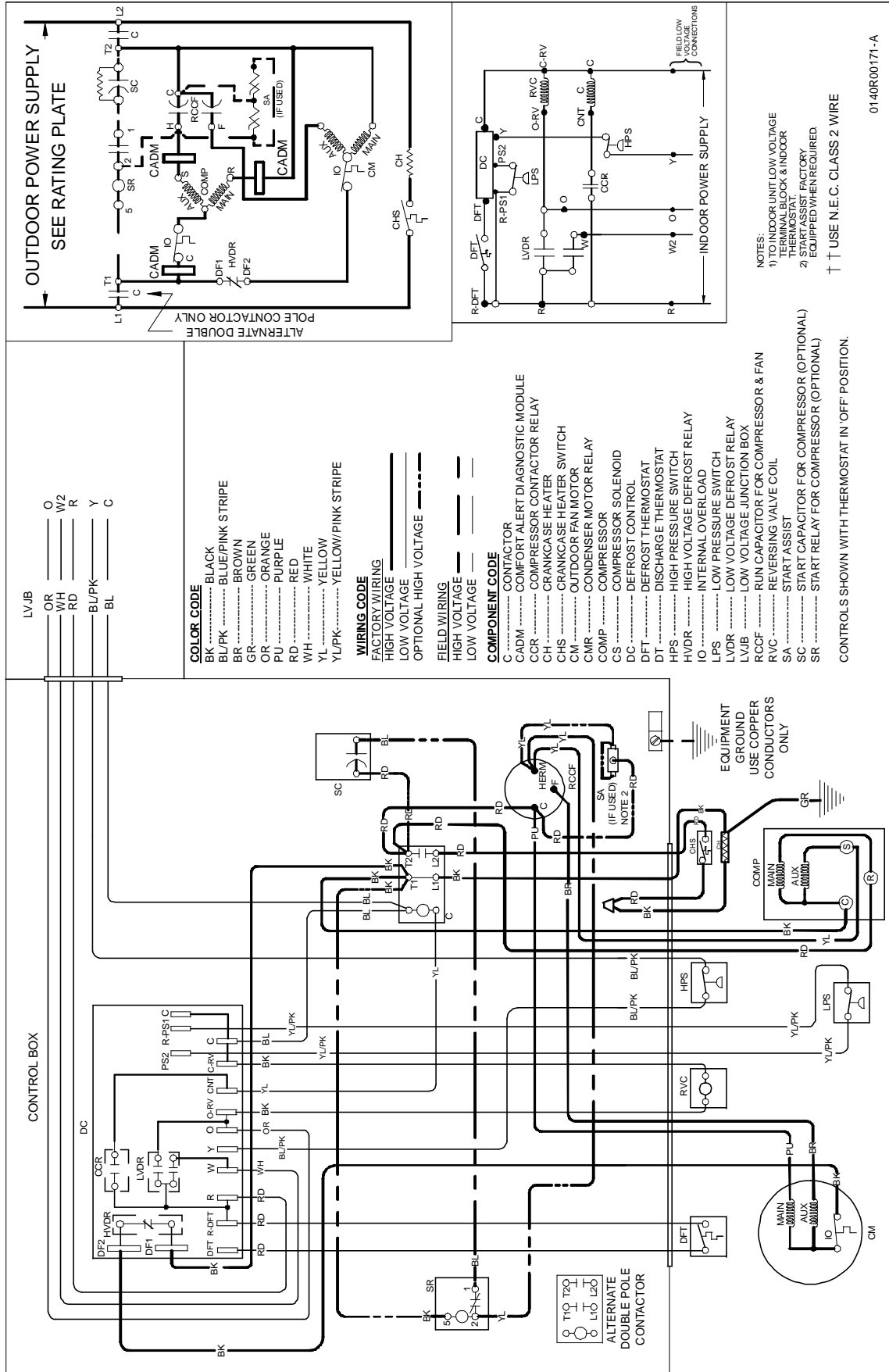

Wiring is subject to change. Always refer to the wiring diagram on the unit for the most up-to-date wiring.

# WIRING DIAGRAMS

VSZ130181A[C/D/E/F], VSZ130241B[B/C/D], VSZ130301A[D/E/F/G]  
 VSZ130361B[B/C/D], VSZ130421A[C/D/E/F/G], VSZ130481A[C/D],  
 VSZ130601AC



**WARNING**  
**HIGH VOLTAGE!**  
 DISCONNECT ALL POWER BEFORE SERVICING OR INSTALLING THIS UNIT. MULTIPLE POWER SOURCES MAY BE PRESENT. FAILURE TO DO SO MAY CAUSE PROPERTY DAMAGE, PERSONAL INJURY OR DEATH.

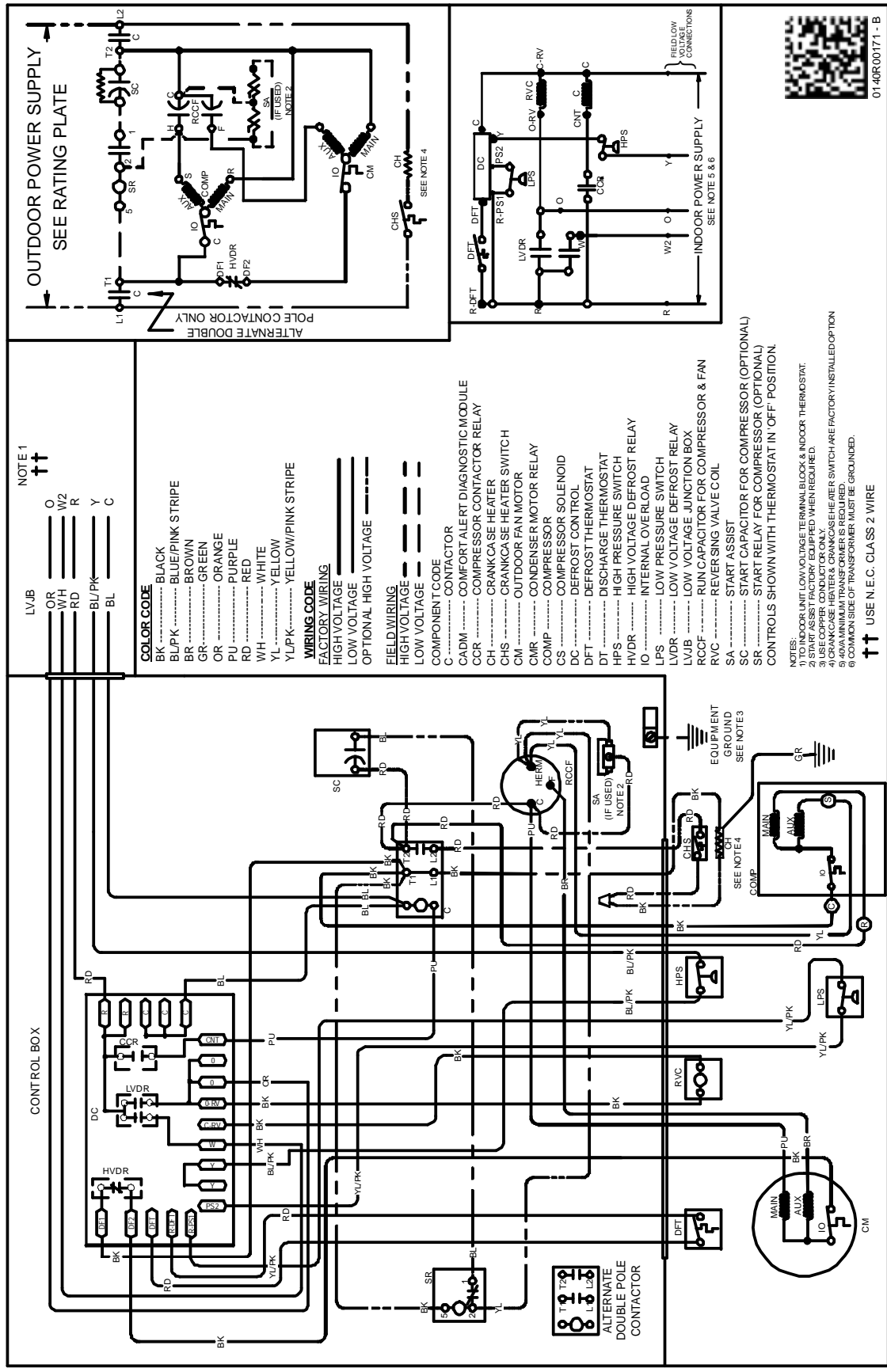

01.40R00171-1-B

Wiring is subject to change. Always refer to the wiring diagram on the unit for the most up-to-date wiring.