

HEATING INPUT: 60,000–100,000 BTU/H

TWO-STAGE, VARIABLE SPEED
 GAS FURNACE
 80% AFUE



Contents

Nomenclature.....	2
Product Specifications.....	3
Dimensions	4
Airflow Data	5
Wiring Diagram	7
Accessories	8

Standard Features

- Two-stage gas valve operates on two-stage or single-stage thermostats
- ComfortNet™ Communications System compatible
- Efficient and quiet variable-speed ECM circulator motor gently ramps up or down according to heating or cooling demand
- SureStart® Silicon Nitride igniter designed for long igniter life
- Furnace control board with self-diagnostics and provisions for electronic air cleaner and 120-volt or 24-volt humidifiers
- Low constant fan speed circulates air throughout the home
- Quiet, two-speed induced draft blower
- California Low NOx emissions-compliant models available
- AHRI Certified; ETL Listed

Cabinet Features

- Fully insulated, heavy-gauge steel cabinet with durable baked-enamel finish
- Installation : dedicated downflow
- Removable bottom for side- or bottom-return applications
- Convenient left or right connection for gas/electric service
- Cabinet air leakage (Q_{Leak}) $\leq 2\%$
- Coil and furnace fit flush for most installations



* Complete warranty details available from your local dealer or at www.amana-hac.com. To receive the Lifetime Unit Replacement Limited Warranty (good for as long as you own your home) and 10-Year Parts Limited Warranty, online registration must be completed within 60 days of installation. Online registration is not required in California or Quebec.

	A	D	V	C	80	040	4	C	*	**	
	1	2	3	4	5,6	7,8,9	10	11	12	13,14	
BRAND	A - Amana® Brand										ENGINEERING
											Major /Minor Revisions * Not used for inventory control.
CONFIGURATION	M - Upflow/Horizontal D - Dedicated Downflow										NOx
											N - Natural Gas X - Low NOx
MOTOR	V - Variable Speed ECM / ComfortNet E - Multi-Speed ECM S - Single Speed										CABINET WIDTH
											A - 14" C - 21" B - 17½" D - 24½"
GAS VALVE	M - Modulating S - Single Stage C - Two Stage H - Convertible Single Phase										MAXIMUM CFM
											2 - 800 CFM 4 - 1600 CFM 3 - 1200 CFM 5 - 2000 CFM
AFUE	80 - 80% AFUE										MBTU/h
											040 - 40,000 BTU/h 100 - 100,000 BTU/h 060 - 60,000 BTU/h 120 - 120,000 BTU/h 080 - 80,000 BTU/h 140 - 140,000 BTU/h

	ADVC8 0603B*B	ADVC8 0805C*B	ADVC8 1005C*B
HEATING CAPACITY			
High Fire Input (BTU/h) ¹	60,000	80,000	100,000
High Fire Output (BTU/h) ¹			
Natural Gas	48,000	64,000	80,000
LP Gas	48,000	64,000	80,000
Low Fire Input (BTU/h) ¹	42,000	56,000	70,000
Low Fire Output (BTU/h) ¹			
Natural Gas	33,600	44,800	56,000
LP Gas	33,600	44,800	56,000
AFUE ²	80	80	80
Available AC @ 0.5" ESP	1.5 - 3.0	2.0 - 5.0	2.0 - 5.0
Temperature Rise Range (° F)	30-60	35 - 65	35-65
CIRCULATOR BLOWER			
Size (D x W)	10" x 8"	10" x 10"	10" x 10"
Horsepower - RPM	¾	¾	¾
Speed	Variable	Variable	Variable
Vent Diameter ²	4"	4"	4"
No. of Burners	3	4	5
ELECTRICAL DATA			
Min. Circuit Ampacity ³	12.1	12.1	12.1
Max. Overcurrent Device (amps) ⁴	15	15	15
SHIP WEIGHT (LBS)	105	125	129

¹ Natural Gas BTU/h; for altitudes above from 0' to 4,500' above sea level, reduce input rating 4% for each 1,000' above 4,500' altitude. Low-fire rate is 70% of high-fire rate.

² DOE AFUE based upon Isolated Combustion System (ICS)

³ Minimum Circuit Ampacity = (1.25 x Circulator Blower Amps) + ID Blower amps. Wire size should be determined in accordance with National Electrical Codes. Extensive wire runs will require larger wire sizes.

⁴ Maximum Overcurrent Protection Device refers to maximum recommended fuse or circuit breaker size. May use fuses or HACR-type circuit breakers of the same size as noted.

NOTES

- All furnaces are manufactured for use on 115 VAC, 60 Hz, single-phase electrical supply.
- Gas Service Connection ½" FPT
- Important: Size fuses and wires properly and make electrical connections in accordance with the National Electrical Code and/or all existing local codes.

DIMENSIONS

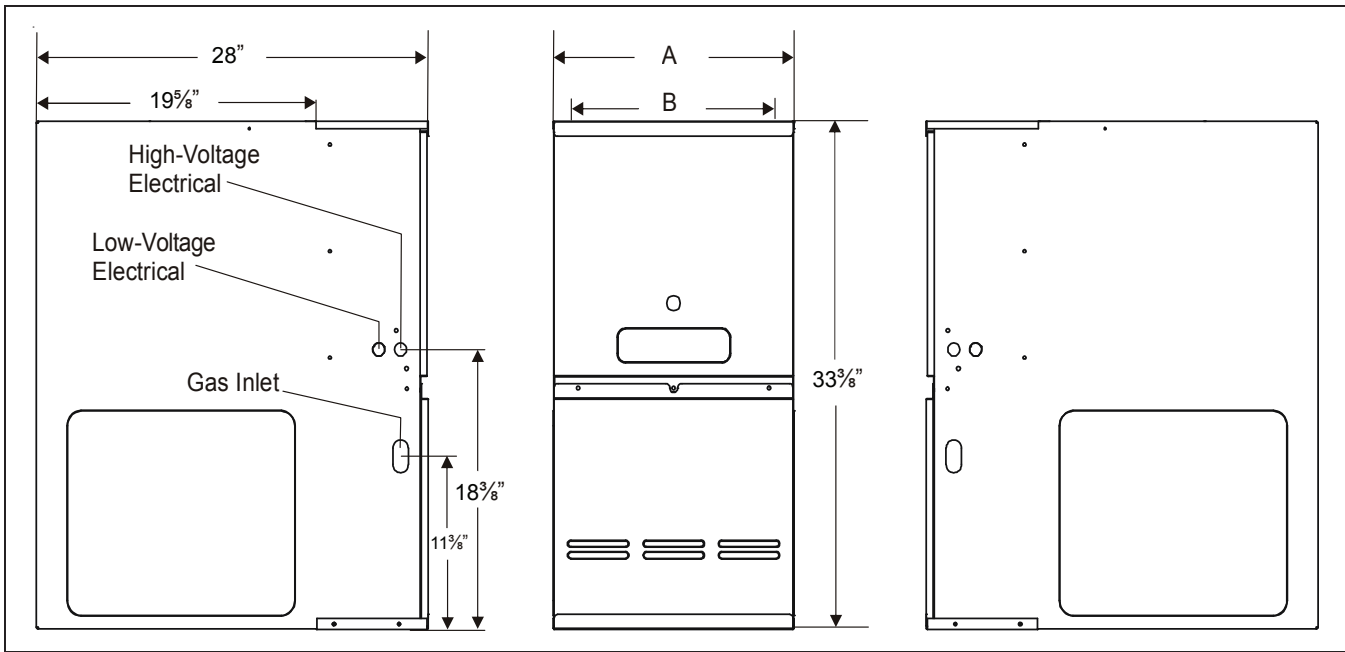

DIMENSIONS

MODEL	A	B
ADVC80603B*B	17 1/2"	16"
ADVC80805C*B	21"	19 1/2"
ADVC81005C*B	21"	19 1/2"

MINIMUM CLEARANCES TO COMBUSTIBLE MATERIALS

SIDES	REAR	FRONT ¹	VENT ²		TOP
			SW	B	
1	0	3	6	1	1

Approved for line contact in the horizontal position.

¹ 24" clearance for serviceability recommended.

² Single Wall Vent (SW) to be used only as a connector. Refer to the venting tables outlined in the Installation Manual for additional venting requirements.

ADVC80603B*B
COOLING SPEEDS
 (@ .1" - .8" w.c. ESP)

TAP	ADJUST	HIGH-STAGE CFM	LOW-STAGE CFM
A	Minus 10%	540	351
	Minus 5%	570	371
	Normal	600	390
	Plus 5%	627	408
	Plus 10%	660	429
B	Minus 10%	720	468
	Minus 5%	760	494
	Normal	800	520
	Plus 5%	836	543
	Plus 10%	880	572
C	Minus 10%	900	585
	Minus 5%	950	618
	Normal	1,000	650
	Plus 5%	1,045	679
	Plus 10%	1,100	715
D	Minus 10%	1,080	702
	Minus 5%	1,140	741
	Normal	1,200	780
	Plus 5%	1,254	815
	Plus 10%	1,320	858

ADVC80603B*B
HEATING SPEEDS
 (@ .1" - .5" w.c. ESP; RISE RANGE: 30° - 60°F)

TAP	ADJUST	HIGH-STAGE CFM	LOW-STAGE CFM	RISE
A	Minus 10%	945	660	55
	Minus 5%	998	698	52
	Normal	1,050	735	49
	Plus 5%	1,097	770	47
	Plus 10%	1,155	810	45
B	Minus 10%	1,035	725	50
	Minus 5%	1,093	765	47
	Normal	1,150	805	45
	Plus 5%	1,202	841	43
	Plus 10%	1,265	885	41
C	Minus 10%	1,125	790	46
	Minus 5%	1,188	831	43
	Normal	1,250	875	41
	Plus 5%	1,306	912	39
	Plus 10%	1,375	960	38
D	Minus 10%	1,215	850	43
	Minus 5%	1,283	898	40
	Normal	1,350	945	38
	Plus 5%	1,411	988	36
	Plus 10%	1,485	1,040	35

ADVC80805C*B
COOLING SPEEDS
 (@ .1" - .8" w.c. ESP)

TAP	ADJUST	HIGH-STAGE CFM	LOW-STAGE CFM
A	Minus 10%	720	468
	Minus 5%	760	494
	Normal	800	520
	Plus 5%	836	543
	Plus 10%	880	572
B	Minus 10%	990	644
	Minus 5%	1,045	679
	Normal	1,100	715
	Plus 5%	1,150	748
	Plus 10%	1,210	787
C	Minus 10%	1,260	819
	Minus 5%	1,330	865
	Normal	1,400	910
	Plus 5%	1,463	951
	Plus 10%	1,540	1,001
D	Minus 10%	1,620	1,053
	Minus 5%	1,710	1,112
	Normal	1,800	1,170
	Plus 5%	1,881	1,223
	Plus 10%	1,980	1,287

ADVC80805C*B
HEATING SPEEDS
 (@ .1" - .5" w.c. ESP; RISE RANGE: 35° - 65°F)

TAP	ADJUST	HIGH-STAGE CFM	LOW-STAGE CFM	RISE
A	Minus 10%	1,215	850	55
	Minus 5%	1,283	898	52
	Normal	1,350	945	49
	Plus 5%	1,411	988	47
	Plus 10%	1,485	1,040	45
B	Minus 10%	1,305	915	51
	Minus 5%	1,378	964	48
	Normal	1,450	1,015	46
	Plus 5%	1,515	1,059	44
	Plus 10%	1,595	1,115	42
C	Minus 10%	1,395	975	48
	Minus 5%	1,473	1,031	45
	Normal	1,550	1,085	43
	Plus 5%	1,620	1,135	41
	Plus 10%	1,705	1,195	39
D	Minus 10%	1,485	1,040	45
	Minus 5%	1,568	1,097	42
	Normal	1,650	1,155	40
	Plus 5%	1,724	1,207	38
	Plus 10%	1,815	1,270	37

See Notes on following page.

ADVC81005C*B
COOLING SPEEDS
 (@ .1" - .8" w.c. ESP)

TAP	ADJUST	HIGH-STAGE CFM	LOW-STAGE CFM
A	Minus 10%	765	497
	Minus 5%	808	525
	Normal	850	553
	Plus 5%	888	578
	Plus 10%	935	608
B	Minus 10%	1,035	673
	Minus 5%	1,093	711
	Normal	1,150	748
	Plus 5%	1,202	781
	Plus 10%	1,265	822
C	Minus 10%	1,305	848
	Minus 5%	1,378	896
	Normal	1,450	943
	Plus 5%	1,515	985
	Plus 10%	1,595	1,037
D	Minus 10%	1,665	1,082
	Minus 5%	1,758	1,143
	Normal	1,850	1,203
	Plus 5%	1,900	1,257
	Plus 10%	2,000	1,323

ADVC81005C*B
HEATING SPEEDS
 (@ .1" - .5" w.c. ESP; RISE RANGE: 35° - 65°F)

TAP	ADJUST	HIGH-STAGE CFM	LOW-STAGE CFM	RISE
A	Minus 10%	1,395	975	61
	Minus 5%	1,473	1,031	58
	Normal	1,550	1,085	55
	Plus 5%	1,620	1,135	52
	Plus 10%	1,705	1,195	50
B	Minus 10%	1,485	1,040	57
	Minus 5%	1,568	1,188	54
	Normal	1,650	1,155	52
	Plus 5%	1,188	1,188	49
	Plus 10%	1,815	1,270	47
C	Minus 10%	1,575	1,105	54
	Minus 5%	1,188	1,188	51
	Normal	1,750	1,225	49
	Plus 5%	1,188	1,188	46
	Plus 10%	1,925	1,350	44
D	Minus 10%	1,620	1,135	53
	Minus 5%	1,188	1,188	50
	Normal	1,800	1,260	47
	Plus 5%	1,188	1,188	45
	Plus 10%	1,980	1,385	43

NOTES

- These charts are for furnaces installed at 0' - 4,500'. At higher altitudes, a properly de-rated unit will have the same temperature rise at a particular CFM, while the ESP at that CFM will be lower.
- The installation must be adjusted to obtain a temperature rise within the range listed on the furnace nameplate.
- Do not operate above .5" w.c. ESP in heating mode.
- Propane gas installations will have a high-stage rise approximately 4°F lower than shown in the tables.

MINIMUM FILTER SIZES

MODEL #	ADVC80603B*	ADVC80805C*	ADVC81005C*
Filter Size (in ²)	(2) 10 x 20 or (1) 16 x 25 (Top Return)	(2) 14 x 20 or (1) 20 x 25 (Top Return)	

Note: Other size filters of equal or greater surface area may be used; filters may also be centrally located.

¹ Use 2 - 16 X 25 filters on side returns or 20 X 25 filter on bottom return if furnace is connected to a cooling unit over 4 tons nominal capacity.

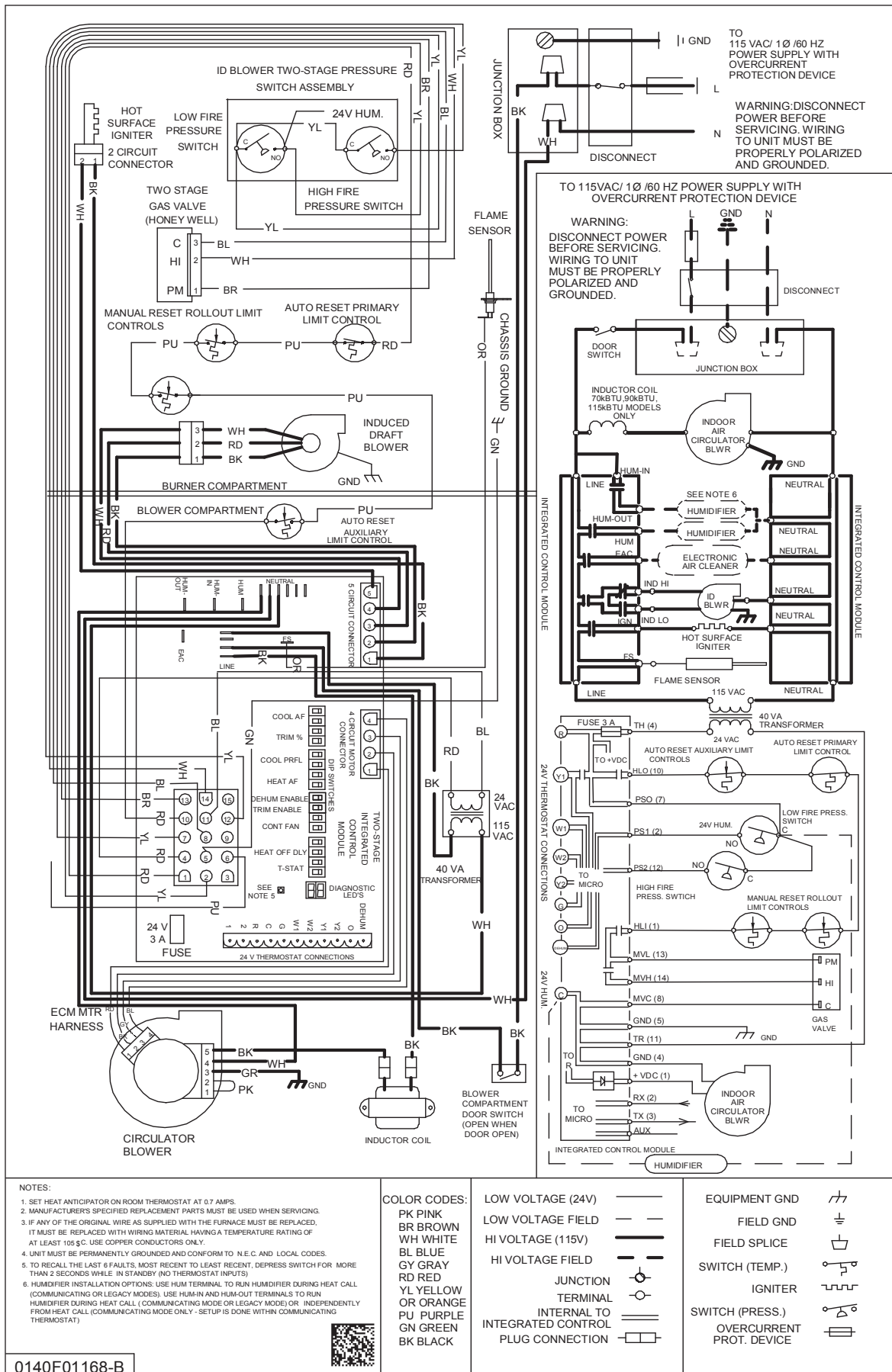

High Voltage: Disconnect all power before servicing or installing this unit. Multiple power sources may be present. Failure to do so may cause property damage, personal injury, or death.

WARNING

Wiring is subject to change. Always refer to the wiring diagram or the unit for the most up-to-date wiring.

MODEL	DESCRIPTION
LPM-06	LP Conversion Kit (Springs & Orifice) ¹
AFE18-60A	Fossil Fuel Kit (must be used in a dual-fuel application with a compatible thermostat)
ASAS	Electronic Air Cleaners (sizes = -10, -11, -12 or -18)
AMU	Media Air Cleaners (sizes = 1620, 2020, 1625 or 2025)

¹ White-Rodgers and Honeywell valves