



QFRESH™



SPECIFICATIONS

QFAM

FRESH AIR SUPPLY FAN



120 CFM @ 0.20" SP., 30.1 Watts
 110 CFM @ 0.20" SP., 27.5 Watts
 100 CFM @ 0.20" SP., 26.3 Watts
 90 CFM @ 0.20" SP., 21.8 Watts
 80 CFM @ 0.20" SP., 19.5 Watts

70 CFM @ 0.20" SP., 17.1 Watts
 60 CFM @ 0.20" SP., 15.1 Watts
 50 CFM @ 0.20" SP., 13.0 Watts
 40 CFM @ 0.20" SP., 11.3 Watts

Blower Wheel

Balanced polymeric dual inlet blower wheel secured in place using a hex nut.

Adjustable Capacity Motor

9 capacity settings allow the fan to be set to the required intake. Set points include: 40 50 60 70 80 90 100 110 120 CFM

4 Pole motor, permanently lubricated, thermally protected
115/120V 60 Hz., 0.30 amps.

Controller

Unit mounted controller monitors temperature and humidity of incoming air and allows installer to configure optimal ventilation.

Fan Housing

Insulated 26 gauge baked epoxy housing. Overall dimensions:
147⁷/₈"H x 11¹/₂"D x 10¹/₈"W.

Duct Collars

6" round, zinc plated metal collar adapters.

Electrical Connections

0.5" electrical access. Easy wiring access via external wiring compartment cover or internal access plate.

Unit Mounting

Designed to surface mount to a wall or ceiling with the included mounting brackets. Can be mounted onto joists, studs or the housing mounting brackets can be adapted for overhead mounting (hardware not provided).

Single Pack Shipping Info

Box Dim: 20" x 15⁷/₈" x 11³/₈"
Shipping Weight: 17 lbs.

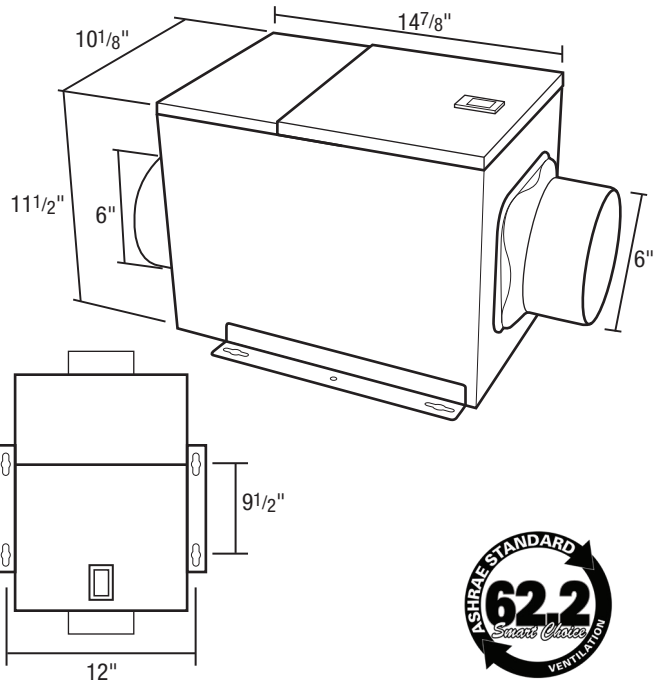

Optional Air Filter

An optional 10" x 10" x 2" air filter can be added to the unit (not included).

Test Port

Allows easy air flow measurement with Pitot tube or similar device.

SEE REVERSE SIDE FOR STATIC PRESSURE RANGES

PROJECT							ARCHITECT			
LOCATION							ENGINEER			
CONTRACTOR							SUBMITTED BY		DATE	
FAN NUMBER	MODEL NUMBER	CFM	IN W.G.	RPM	WATTS	AMPS	SONES	QTY	OPTIONAL EQUIPMENT & REMARKS	



820 Lincoln Avenue • West Chester, Pennsylvania 19380-4466



QFRESH™



SPECIFICATIONS

QFAM

FRESH AIR SUPPLY FAN

ACHIEVABLE STATIC PRESSURES

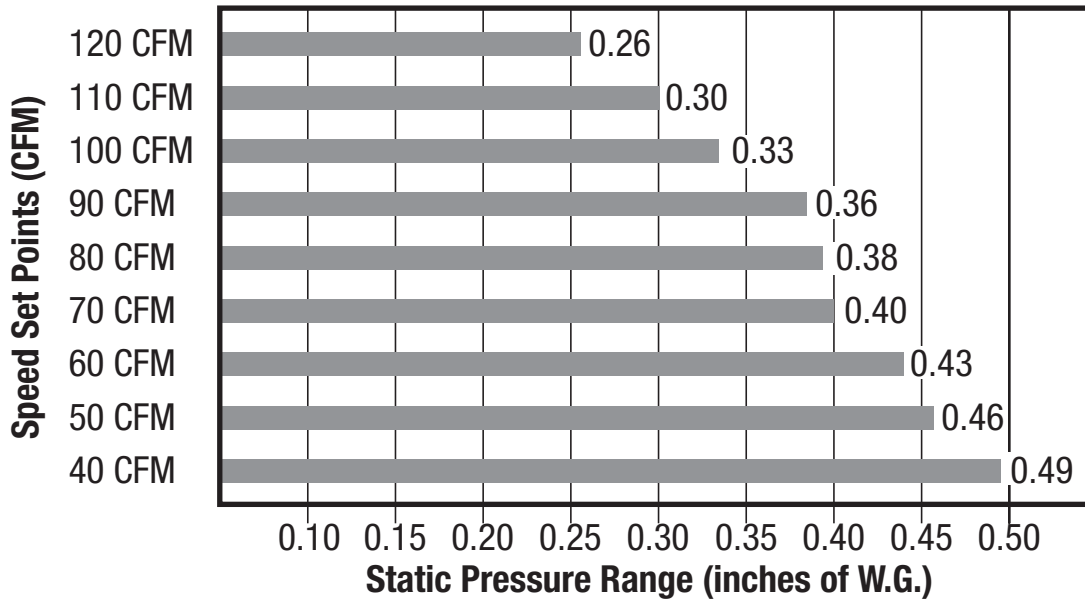

OUTLET FAN SONES

CFM @ 0.2"	40	50	60	70	80	90	100	110	120
Static Pressure									
Sones	0.4	0.5	0.6	0.7	0.9	1.0	1.2	1.4	1.6

The sound ratings shown are loudness values in spherical sones at a distance of 1.5 m (5 ft) in a hemispherical free field calculated per AMCA Standard 301. Values shown are for: Installation Type D: ducted outlet spherical sone levels. Ratings do not include the effect of duct end correction.

The HVI certified ratings program does not provide for sound ratings of inline fans, so these values are not HVI certified.

AMCA does have a program for testing and rating sound for inline fans but Air King is not an AMCA member so these values are not AMCA licensed. The testing was performed at the AMCA laboratory in Arlington Heights, IL. The outlet duct length was 18" (3 duct diameters) of galvanized steel duct with no acoustic insulation with a bell mouth termination fitting.



820 Lincoln Avenue • West Chester, Pennsylvania 19380-4466