

Specification Guide

FSA, FOA, SEP & HED Series

Unit Heaters and Duct Furnaces



Product improvement is a continuous process at Advanced Distributor Products. Therefore, product specifications are subject to change without notice and without obligation on our part. Please contact your ADP representative or distributor to verify details.

© by Advanced Distributor Products. All rights reserved.

PRODUCT NOMENCLATURE

FOA / FSA Nomenclature

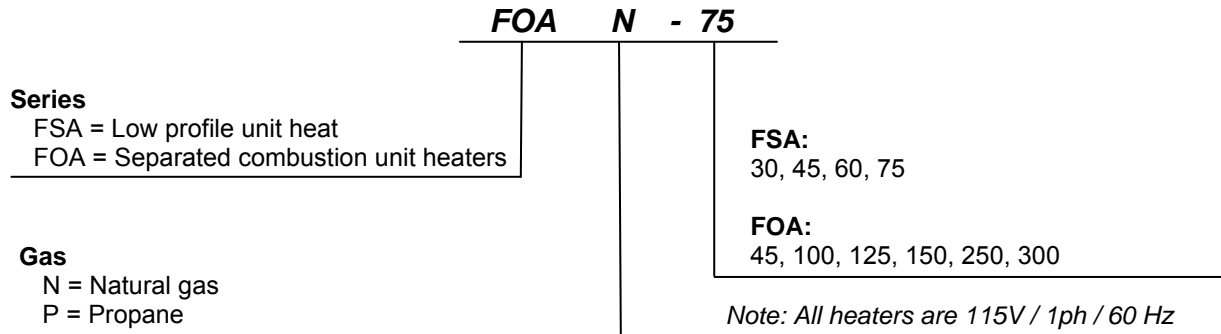

SEP / HED Nomenclature

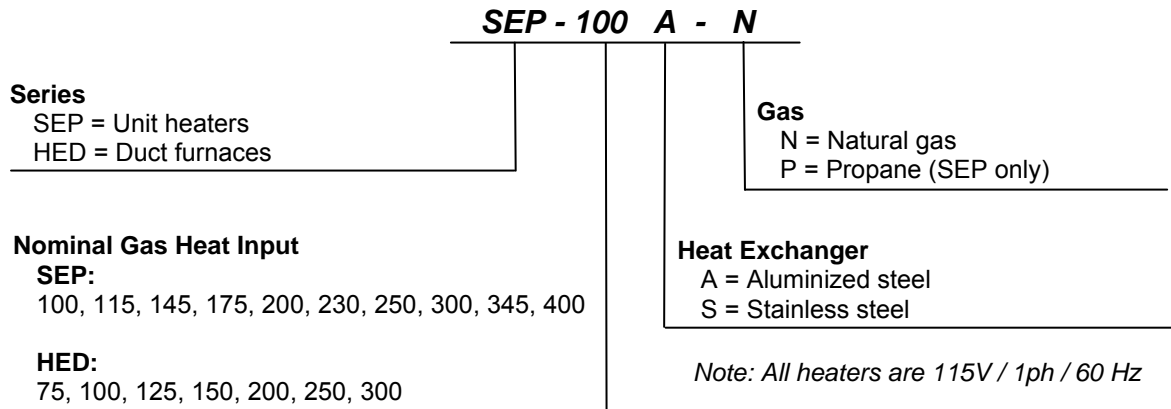

PRODUCT FEATURES

Efficiency

ADP gas-fired unit heaters and duct furnaces deliver between 80% and 82% thermal efficiency. This excellent efficiency sets a new standard when using gas-fired unit heaters and duct furnaces.

Reliability

ADP heater designs have proven superior for over a decade and during hundreds of thousands of hours in the toughest winter climates of North America and under extreme conditions in laboratory life cycle testing. ADP unit heaters and duct furnaces have been designed to provide a long, trouble free service life.

Quality

Every heater undergoes continuous quality checks at all stages of manufacturing. After assembly, each heater is test fired and functionally tested to provide final assurance that it is performing in accordance with ADP's rigorous quality standards.

Approvals

All ADP heaters are built in the USA in an ISO 9001:2008 facility. The rating plate of each heater carries the mark signifying that the heater is design certified by CSA. In addition, the heater series is listed by the California Energy Commission (CEC).

Warranty

ADP unit heaters feature a standard 2-year limited warranty. For FOA, FSA, and SEP Series, the warranty provides extended coverage on aluminized heat exchangers for 10 years. For SEP Series, the warranty provides extended coverage on stainless steel heat exchangers for 15 years.

Power Exhaust

All heaters have a sealed flue collector and a power exhaust system which enable conventional vertical venting or horizontal venting. Power exhaust, when used with horizontal venting, lowers operating cost because it reduces stack losses. It also allows the option of not penetrating the roof, or multiple floors. The versatile power exhaust (on some models) reduces installation cost further by allowing the exhaust to be directed upward, left or right, just by rotating the exhaust assembly.

In Shot Burners

These lightweight aluminized steel burners are maintenance-free and never require adjustment. The burner venturi mixes air and gas in the correct proportion for efficient combustion. The entire burner assembly is removable as one piece for ease of service.

Tubular Heat Exchangers

Constructed of aluminized steel for superior resistance to corrosion and oxidation; for additional protection, some models have an optional stainless steel heat exchanger. The curving design provides for complete exposure of the heating surface to the supply air stream. Rounded surfaces minimize air resistance and permit air to surround all heat transfer surfaces for excellent heat transfer. Tubular design means lighter weight and significantly longer service life due to lower thermal-induced stresses. .

Direct Spark Ignition

In combination with the 24-volt main gas valve with 100% shutoff for safety, the direct spark ignition control provides positive, reliable and safe main burner ignition. This eliminates the need for a pilot light, improving system efficiency and reliability. A separate flame sensor provides proof of main burner ignition. If loss of main burner flame should occur, the control will reinitiate ignition three times before locking out, thus reducing nuisance service calls. The unit will reinitiate ignition after the one hour lockout. The prepurge operation safety removes all gas and flue products from the system prior to ignition.

Cabinet

Constructed heavy gauge painted steel, each cabinet has a two-point suspension system for easy installation (larger and two-fan models have four-point suspensions). Generous use of inside cabinet insulation keeps the outer surface temperature low. The wiring junction box is conveniently located on the side of the cabinet (SEP & HED only) for easy access and adequate protection.

Product Features

- Residential – low profile units.
- Great for garages & shops.
- Sidewall venting eliminates roof penetrations.
- Wiring junction box is located inside of unit.
- 1” clearance from ceiling for easy installation.
- Heating capacities from 30,000 – 75,000 BTUH.
- Up to 81% thermal efficiency.
- Self-diagnostic board with LED display improves troubleshooting.
- Power exhaust system allows horizontal venting to 25 ft.
- Tubular heat exchangers made of aluminized steel.
- Aluminized steel in shot burners provide efficient trouble free operation.
- Direct drive propeller fans are dynamically balanced for quiet and smooth operation.



Technical Data

	Model	FSA* -30 ^[1]	FSA* -45 ^[1]	FSA* -60	FSA* -75
Gas Heating Performance	Heating Capacity Input (BTUH)	30,000	40,000	60,000	75,000
	Heating Output (BTUH)	24,300	32,500	48,000	60,000
	Steady State Efficiency	81.0%	81.0%	80.0%	80.0%
	Temp Rise (deg F)	42	45	55	60
Connections	Flue Size Round (in)	3 ^[2]	3 ^[2]	4 ^[3]	4 ^[3]
	Gas Piping Size (in, NPT)	1/2	1/2	1/2	1/2
Fan Data	Num of Fans	1	1	1	1
	Diameter (in)	10	10	14	14
	Num of Blades	4	4	3	3
	Motor Output (hp)	1/20	1/20	1/10	1/10
	Motor Full Load Amps	1.7	1.7	4.1	4.1
	Motor RPMs	1650	1650	1050	1050
	Air Volume (CFM)	535	750	830	950
Physical Data	Overall Dimensions H x W x D (in)	12 x 25 x 24	12 x 25 x 24	17 x 25 x 25	17 x 25 x 25
	Ship Weight (lbs)	45	50	87	91

* N = Natural gas; P = LP gas

[1] Sold in pallet quantities of four(4) per model. No mix or match of models.

[2] 2-1/8 x 3 in. (54 x 76 mm) diameter adaptor is furnished with unit for flue connection.

[3] 2 x 4 in. (51 x 102 mm) diameter adaptor is furnished with unit for flue connection.

Note: All models have aluminized steel heat exchanger; all models are 115 V, 60 Hz, 1 phase.

Dimensions

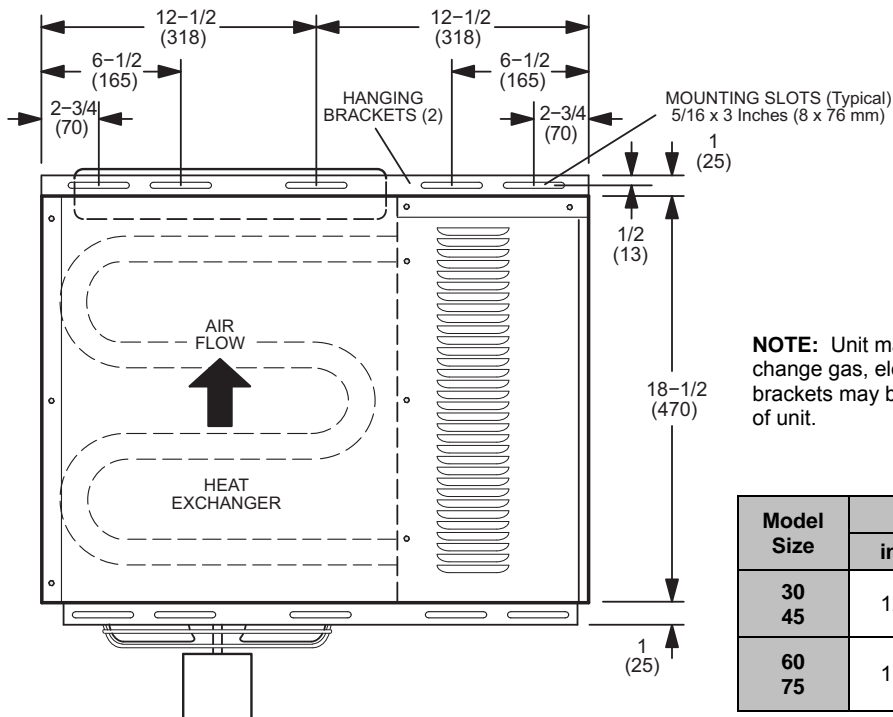

NOTE: Unit may be rotated 180° top for bottom to change gas, electrical and flue positions. Hanging brackets may be installed on either top or bottom of unit.

Model Size	A		B		C	
	in.	mm	in.	mm	in.	mm
30 45	12	305	5-1/2	140	4-1/4	108
60 75	17	432	6-1/2	165	6-3/4	171

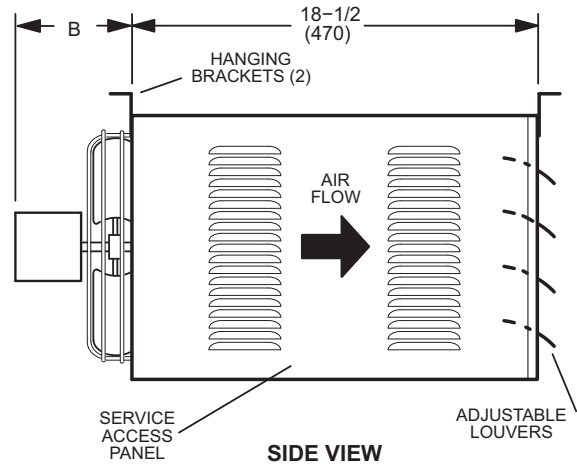
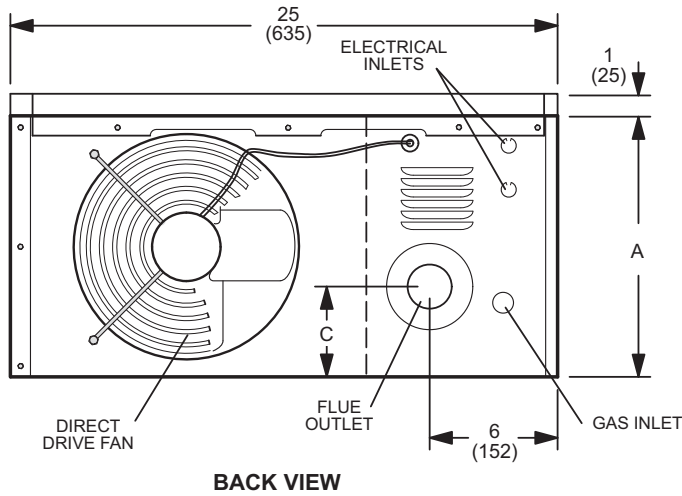

Product Features

- Perfect for light commercial and greenhouse applications.
- Introduces clean combustible outside air when required.
- Wiring junction box is located outside of unit.
- Ideal for hard-to-heat applications where excessive dust, dirt, humidity, or negative pressure is a concern.
- Heating capacities from 40,000 – 300,000 BTUH.
- Up to 82% thermal efficiency.
- Compact cabinet design on 40,000 – 75,000 BTUH models.
- Hinged door allows easy access to components.
- Sidewall venting eliminates roof penetrations.
- Self-diagnostic board with LED display improves troubleshooting efficiency and accuracy.
- Tubular heat exchangers made of aluminized steel.
- Power exhaust system allows horizontal venting to 25 ft.
- Direct drive propeller fans are dynamically balanced for quiet and smooth operation.



Technical Data

	Model	FOA* -45	FOA* -100	FOA* -125	FOA* -150 [1]	FOA* -250 [1]	FOA* -300 [1]
Gas Heating Performance	Heating Capacity Input (BTUH)	40,000	100,000	125,000	150,000	240,000	300,000
	Output Natural Gas (BTUH)	32,400	81,000	101,500	120,000	194,400	240,000
	Output LPG / Propane (BTUH)	32,400	82,700	101,500	121,500	196,800	243,000
	Thermal Efficiency -- Natural Gas	81%	82%	81%	80%	81%	80%
	Thermal Efficiency -- LPG / Propane	81%	81%	81%	81%	82%	81%
	Temp Rise (deg F)	45	31	39	38	35	43
Connections	Flue Size Round (in)	3	5	5	5	5	6
	Combustion Air Size Round (in)	3	4	4	4	4	4
	Gas Piping Size (in, NPT)	1/2	1/2	1/2	1/2	3/4	3/4
Fan Data [2]	Number of Fans	1	1	1	1	2	2
	Diameter (in)	10	16	16	18	16	16
	Number of Blades	5	4	4	4	4	4
	Motor Output (hp)	1/20	1/8	1/8	1/8	1/8	1/8
	Motor Full Load Amps	1.7	2.7	2.7	2.7	2.7	2.7
	Motor RPMs	1650	1075	1075	1075	1075	1075
Physical Data	Air Vol. (CFM)	750	2435	2435	2955	5215	5215
	Overall Dimensions H x W x D (in)	12 x 26 x 24	21 x 36-1/2 x 39-5/8	21 x 36-1/2 x 39-5/8	27 x 36-1/2 x 39-5/8	39 x 36-1/2 x 39-5/8	39 x 36-1/2 x 39-5/8
	Ship Weight (lbs)	84	188	204	261	307	323

* N = Natural gas; P = LP gas

[1] Models not approved for residential applications.

[2] Fan motor type: SP for models 45; PSC for models 100, 125, 150, 250, 300.

Note: All models are 115 V, 60 Hz, 1 phase.

Dimensions (45 model)

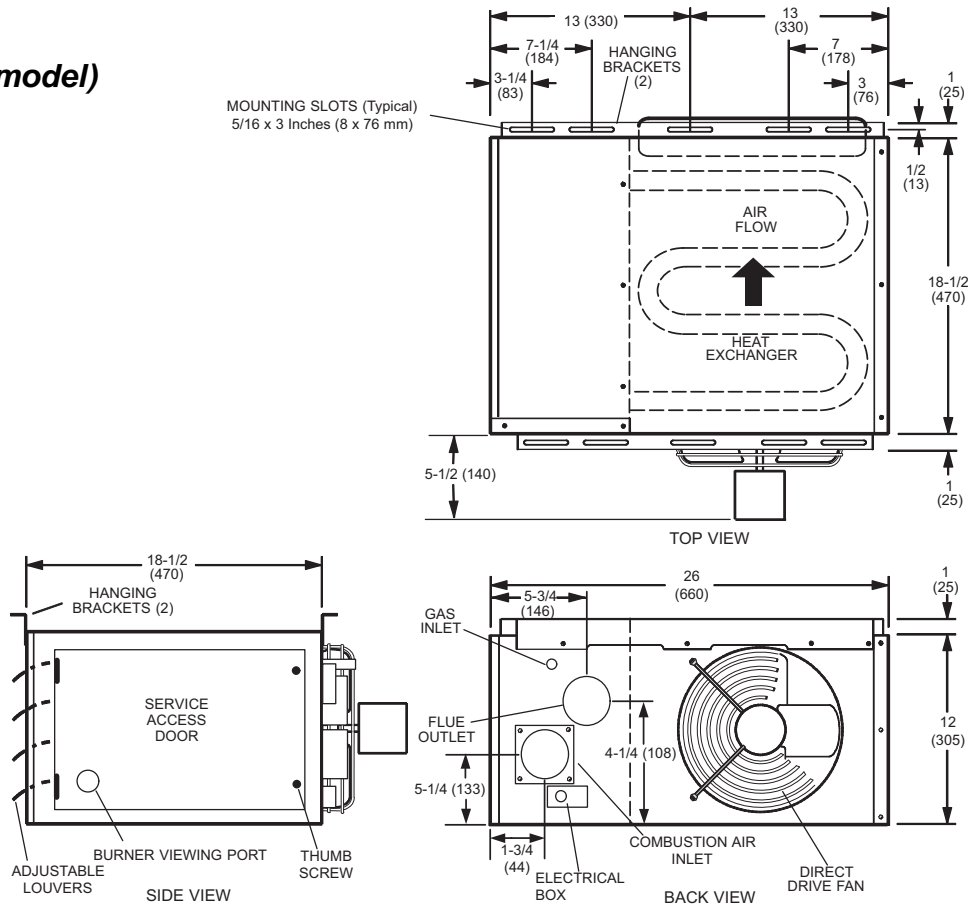

Dimensions (100—300 models)

Model Size	A		B	
	in.	mm	in.	mm
100 125	21	533	8-1/2	216
150	27	686	8-5/8	219
250 300	39	991	22-1/2	572

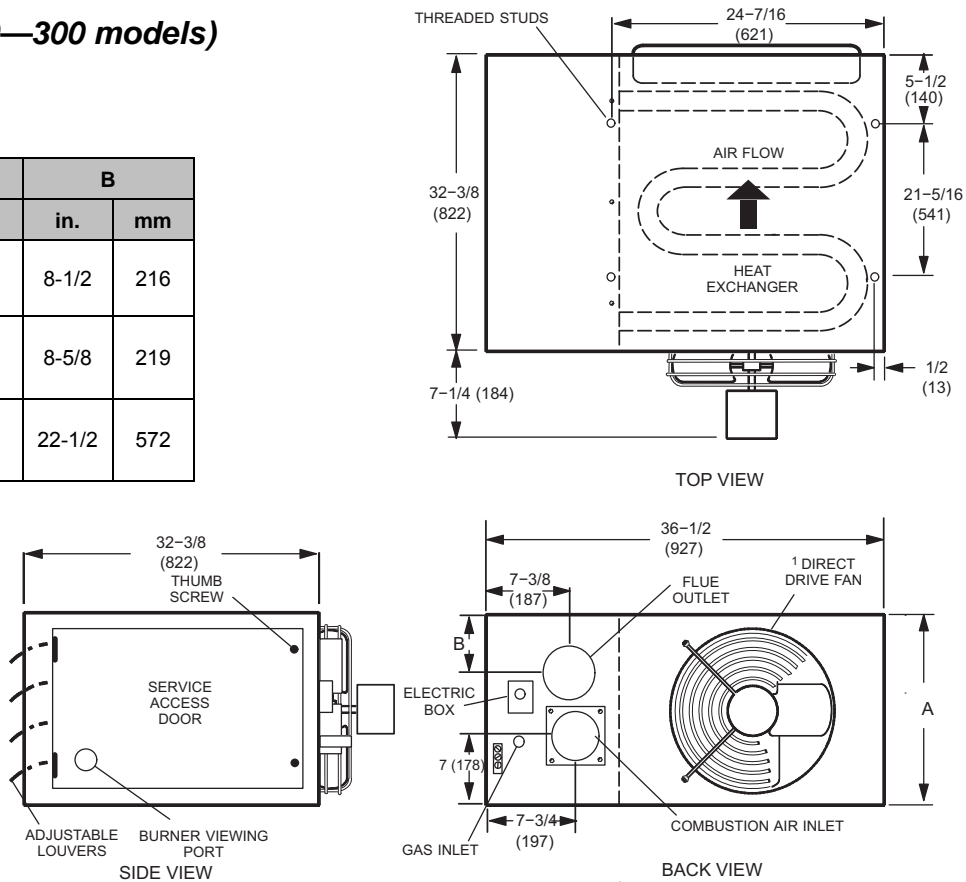

¹ FOA250 and FOA300 models have two fans.

Product Features

- Heating capacities from 100,000 – 400,000 BTUH.
- Up to 80.5% thermal efficiency.
- Stainless steel heat exchanger is available for longer product life.
- Heat exchangers are laboratory life-cycle tested.
- Tubular heat exchangers made of aluminized steel or stainless steel.
- Aluminized steel in shot burners provide efficient trouble free operation.
- Sidewall venting eliminates roof penetrations.
- Wiring junction box is located outside of unit.
- Safe direct spark ignition. No standing pilot light.
- Self-diagnostic board with LED display improves troubleshooting efficiency and accuracy.
- 3/8 x 16 rivet nuts are located on the top of cabinet for suspending unit using threaded rod.
- Power exhaust system with a sealed flue collector allows conventional vertical or horizontal venting to 35 ft (depends on unit size).
- Direct drive propeller fans are dynamically balanced for quiet, smooth operation.



Technical Data

	Model	SEP -100#-&	SEP -115#-&	SEP -145#-&	SEP -175#-&	SEP -200#-&	SEP -230#-&	SEP -250#-&	SEP -300#-&	SEP -345#-&	SEP -400#-&
Gas Heating Performance	Heating Capacity Input (BTUH)	100,000	115,000	145,000	172,500	195,000	230,000	250,000	300,000	345,000	390,000
	Output Natural Gas (BTUH)	80,500	92,000	116,000	138,000	156,000	184,000	201,250	241,500	276,000	312,000
	Output LPG/Propane (BTUH)	82,000	92,000	115,000	138,000	156,000	184,000	205,000	246,000	281,200	312,000
	Steady State Efficiency -- Natural Gas	80.5%	80.0%	80.0%	80.0%	80.0%	80.0%	80.5%	80.5%	80.0%	80.0%
	Steady State Efficiency -- LPG / Propane	82.0%	80.0%	80.0%	80.0%	80.0%	80.0%	82.0%	82.0%	81.5%	80.0%
Connections	Flue Size Round (in)	4 ^[1]	4 ^[1]	4 ^[1]	5 ^[2]	5 ^[2]	5 ^[2]	5 ^[2]	5 ^[2]	6 ^[3]	6 ^[3]
	Gas Piping Size (in, NPT)	1/2	1/2	1/2	1/2	1/2	3/4	3/4	3/4	3/4	3/4
Fan Data	Number of Fans	1	1	1	1	1	2	2	2	2	2
	Diameter (in)	16	16	16	16	16	16	16	16	16	16
	Number of Blades	4	4	4	4	4	4	4	4	4	5
	Motor Output (hp)	1/8	1/8	1/8	1/8	1/8	1/8	1/8	1/8	1/8	1/8
	Motor Full Load Amps	2.1	2.1	2.1	2.1	2.1	2.1	2.1	2.1	2.1	2.1
	Motor RPMs	1075	1075	1075	1075	1075	1075	1075	1075	1075	1075
Air Volume (CFM)	1900	1900	1900	2200	2200	4400	4400	4400	4400	4400	
Physical Data	Overall Dimensions H x W x D (in)	32-3/16 x 20-3/16 x 39-3/16	32-3/16 x 20-3/16 x 39-3/16	32-3/16 x 20-3/16 x 39-3/16	32-3/16 x 23-1/8 x 39-3/16	32-3/16 x 23-1/8 x 40	32-3/16 x 41-1/8 x 40	32-3/16 x 41-1/8 x 40	32-3/16 x 41-1/8 x 40	32-3/16 x 41-1/8 x 41-1/8	32-3/16 x 41-1/8 x 41-1/8
	Ship Weight (lbs)	150	150	165	185	185	275	275	280	310	315

[1] 2-1/8 x 4 in. (54 x 102 mm) diameter adaptor is furnished with unit for flue connection.

[2] 2-1/4 x 2-3/4 in. (57 x 70 mm) rectangular to 5 in. (127 mm) round adaptor is furnished with unit for flue connection.

[3] 2-1/4 x 2-3/4 in. (57 x 70 mm) rectangular to 6 in. (152 mm) round adaptor is furnished with unit for flue connection.

A = Aluminized steel heat exchanger; S = Stainless steel heat exchanger; All models are 115 volts, 60 Hz, 1 phase.
& N = Natural Gas; P = LP Gas

Note: SEP unit heaters are not approved for residential applications.

Dimensions

NOTE: Single fan model shown.
 SEP models 100, 115, 145, 175 and 200 have a single fan.
 SEP models 230, 250, 300, 345 and 400 have two fans.

*** NOTE:** Two mounting nuts are furnished on SEP models 100, 115, 145, 175 and 200.
 Four mounting nuts are furnished on SEP models 230, 250, 300, 345 and 400 models.

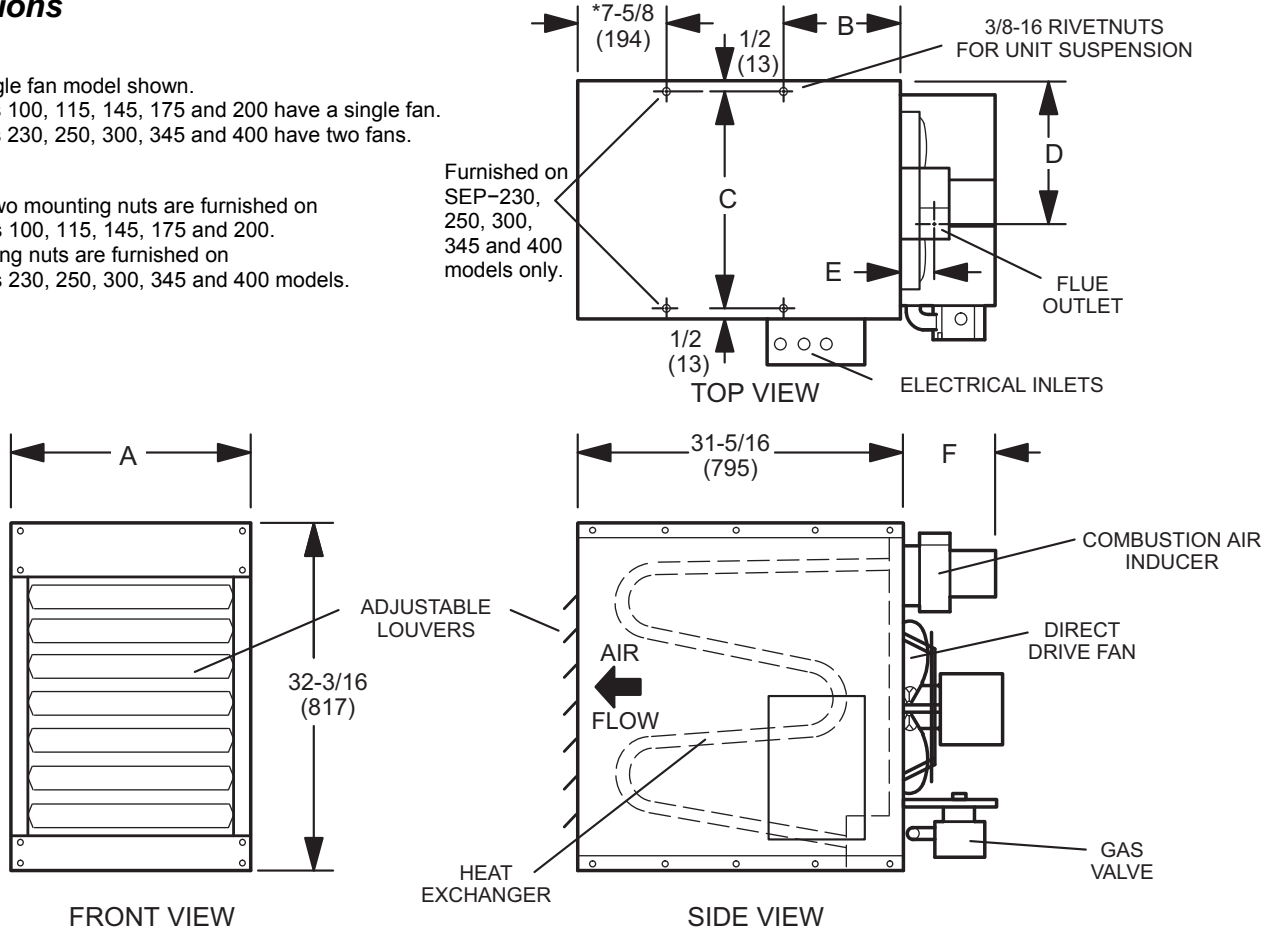

Model Size	A		B		C		D		E		F	
	in.	mm	in.	mm	in.	mm	in.	mm	in.	mm	in.	mm
100 115 145	20-3/16	512	11-1/2	292	19-1/16	484	11-3/4	298	3-1/4	83	7-7/8	200
175 200	23-1/8	588	11-1/2	292	22-1/16	560	8-1/2	337	3-1/4	83	8-11/16	220
230 250 300	41-1/8	1045	3-11/16	97	40	1016	17-3/4	451	3-1/2	89	8-11/16	220
345 400	41-1/8	1045	3-11/16	97	40	1016	17-1/2	445	3-1/2	89	9-13/16	248

Product Features

- Specially designed for applications requiring duct systems.
- Heating capacities from 75,000 – 300,000 BTUH.
- 80% thermal efficiency.
- Stainless steel heat exchanger is available for longer product life.
- Sidewall venting eliminates roof penetrations.
- Wiring junction box is located outside of unit.
- Self-diagnostic board with LED display improves troubleshooting efficiency and accuracy.
- 3/8 x 16 rivet nuts are located on the top of cabinet for suspending unit using threaded rod.
- Heat exchangers are laboratory life-cycle tested.
- Aluminized steel in shot burners provide efficient trouble free operation.
- Power exhaust system with a sealed flue collector allows conventional vertical or horizontal venting to 35 ft. (depending on unit size).
- Safe direct spark ignition. No standing pilot light.
- Tubular heat exchangers made of aluminized steel or stainless steel.
- Factory installed condensate drain allows for use downstream of cooling systems.

Technical Data

	Model	HED-75#	HED-100#	HED-125#	HED-150#	HED-200#	HED-250#	HED-300#
Gas Heating Performance	Heating Capacity Input (BTUH)	75,000	100,000	125,000	150,000	200,000	250,000	300,000
	Heating Output (BTUH)	60,000	80,000	100,000	120,000	160,000	200,000	240,000
	Steady State Efficiency	80.0%	80.0%	80.0%	80.0%	80.0%	80.0%	80.0%
	Air Volume Throughput (CFM)	780- 2700	870 - 3700	1020 - 4700	1320 - 5600	1480 - 4230	1850 - 5290	2220 - 6200
	Temp Rise (deg F)	21 - 71	20 - 85	20 - 91	20 - 84	35 - 100	35 - 100	36 - 100
Connections	Flue Size Round (in)	4 ^[1]	4 ^[1]	4 ^[1]	4 ^[1]	5 ^[2]	5 ^[2]	5 ^[2]
	Gas Piping Size (in, NPT)	1/2	1/2	1/2	1/2	3/4	3/4	3/4
	Cond. Drain Size (in)	1/4	1/4	1/4	1/4	1/4	1/4	1/4
Physical Data	Overall Dimensions H x W x D (in)	28-5/16 x 19-1/2 x 34-11/16	32-3/16 x 20-1/8 x 40	32-3/16 x 20-1/8 x 40	32-3/16 x 23-1/8 x 40	32-3/16 x 41-1/8 x 40	32-3/16 x 41-1/8 x 40	32-3/16 x 41-1/8 x 40
	Ship Weight (lbs)	115	140	150	165	270	285	305

A = Aluminized steel heat exchanger; S = Stainless steel heat exchanger; all models are 115 volts, 60 Hz, 1 phase.

[1] 2-1/4 x 4 in. (57 x 102 mm) round flue adaptor is furnished with unit for flue connection.

[2] 2-1/4 x 2-3/4 in. (57 x 70 mm) rectangular to 5 in. (127 mm) round adaptor is furnished with unit for flue connection.

Note: HED duct furnaces are not approved for residential applications.

Performance Ratings

Unit Size	Air Volume (CFM)	Total Resistance (inches W.C)	Temp Rise (deg F)
75	780	0.01	71
	1000	0.02	56
	1300	0.05	43
	1600	0.07	35
	1900	0.10	29
	2200	0.12	25
	2500	0.17	22
	2700	0.20	21
100	870	0.02	85
	900	0.02	82
	1300	0.03	57
	1700	0.06	44
	2100	0.09	35
	2500	0.12	30
	2900	0.15	26
	3300	0.18	22
	3700	0.23	20
125	1020	0.03	91
	1100	0.03	84
	1600	0.06	58
	2100	0.11	44
	2600	0.16	36
	3100	0.21	30
	3600	0.26	26
	4100	0.31	23
	4600	0.36	20
	4700	0.37	20
150	1320	0.02	84
	1400	0.03	79
	2000	0.07	56
	2600	0.12	43
	3200	0.20	35
	3800	0.28	29
	4400	0.37	25
	5000	0.45	22
	5600	0.55	20

Unit Size	Air Volume (CFM)	Total Resistance (inches W.C)	Temp Rise (deg F)
200	1480	0.03	100
	1500	0.03	99
	2000	0.04	74
	2500	0.07	59
	3000	0.09	49
	3500	0.13	42
	4000	0.15	37
	4230	0.16	35
	250	1850	0.04
2000		0.05	93
2500		0.08	74
3000		0.11	62
3500		0.13	53
4000		0.17	46
4500		0.19	41
5000		0.23	37
5290		0.25	35
300		2220	0.07
	2800	0.11	79
	3400	0.14	65
	4000	0.18	56
	4600	0.23	48
	5200	0.26	43
	5800	0.31	38
	6190	0.33	36
	6200	0.33	36

Dimensions

*** NOTE:** Two rivet nuts are furnished on HED models 75, 100, 125 and 150. Four rivet nuts are furnished on HED models 200, 250 and 300

Additional 3/8-16 rivet nuts for unit suspension (furnished on HED models 200, 250 and 300).

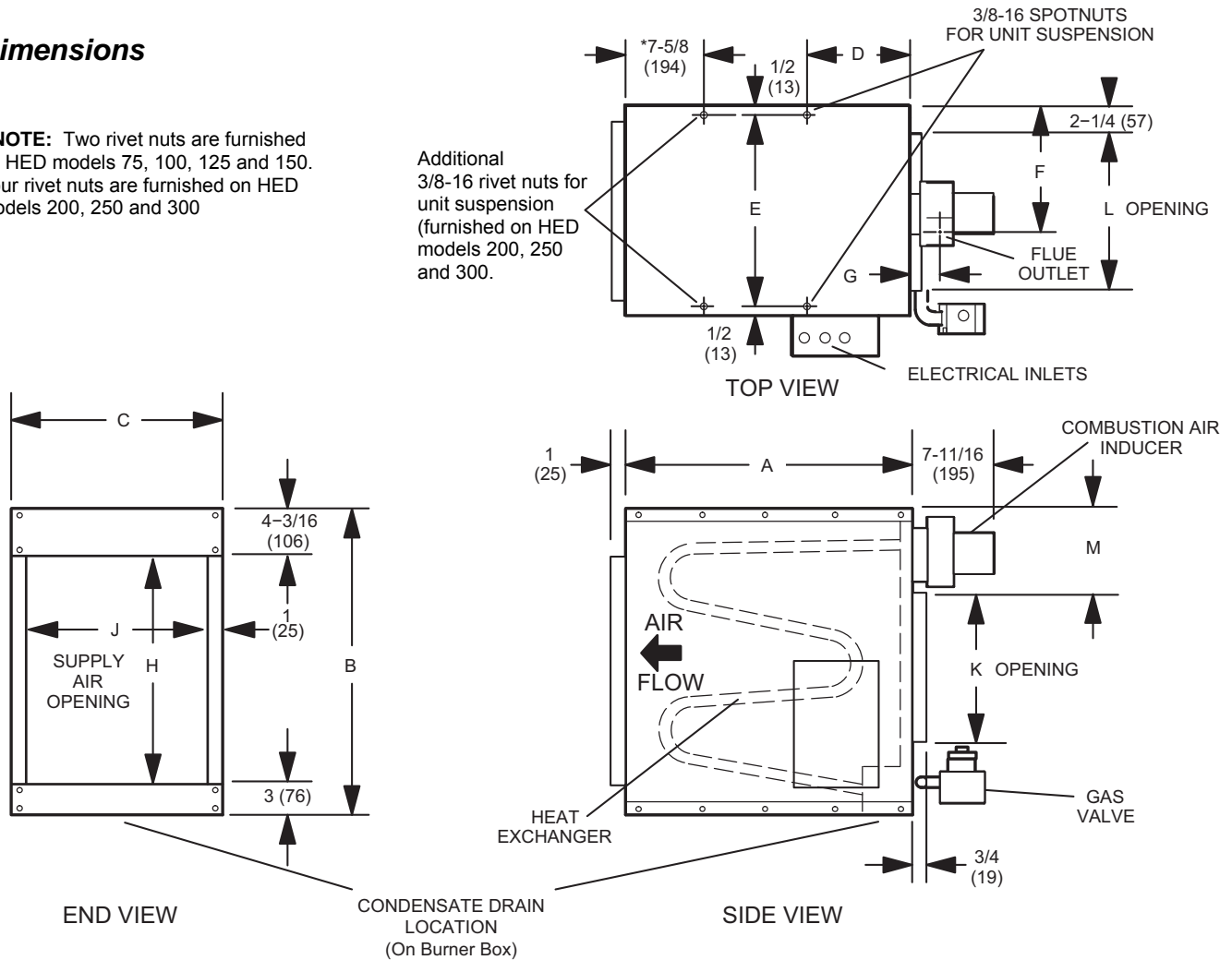

Model Size		A	B	C	D	E	F	G	H	J	K	L	M
75	in.	26	28-5/16	19-1/2	8-1/2	18-1/2	11-3/4	2-1/2	21-1/8	17-1/2	13-3/8	15	7-5/16
	mm	660	719	495	216	469	298	64	537	445	340	381	186
100 125	in.	31-5/16	32-3/16	20-1/8	10-1/2	19-1/16	11-3/4	3-1/4	25	18-1/8	15-3/8	15-5/8	9-5/16
	mm	795	818	511	267	484	298	83	635	460	391	397	237
150	in.	31-5/16	32-3/16	23-1/8	11-3/8	23-1/16	8-1/2	3-1/4	25	21-1/8	15-3/8	17-1/8	8-15/16
	mm	795	818	587	289	586	216	83	635	537	391	435	227
200 250 300	in.	31-5/16	32-3/16	41-1/8	3-11/16	40	17-1/2	3-1/4	25	39-1/8	15-3/8	35-1/16	9
	mm	795	818	1045	97	1016	445	83	635	994	391	891	229

