

# PGMDD101/102, -103 AND PGMDMD101/102, -103 25% MANUAL AND MOTORIZED FRESH AIR DAMPER

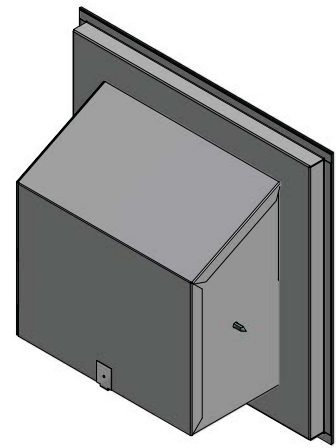

## APPLICATION

Most building codes require a certain amount of fresh air be introduced into the interior space. Use of fresh air dampers on HVAC equipment is an inexpensive way to allow fresh air into the building. McDaniel metals offers both a manual and motorized fresh air damper to fit Goodman light commercial packaged equipment. The manual fresh air damper is installed and fixed in place to allow a certain amount of fresh air to circulate at all times. The motorized fresh air damper includes a small two position actuator that opens the damper when the indoor blower is running and closes the damper when the blower turns off.

## MANUAL FRESH AIR DAMPER INSTALLATION

1. Remove the damper assembly from its container and inspect for damage or shortages
2. Locate and remove the panel covering the horizontal return air opening. Retain the screws for step 3.
3. Attach the damper to the side of the machine using the screws from step 2 and weatherproof with silicone sealant or other approve method where indicated in figure 1.
4. Loosen the wing nut on the damper handle and adjust the damper position until the required amount of fresh air is entering the space.
5. Tighten the wing nut to secure the damper.

## MOTORIZED FRESH AIR DAMPER INSTALLATION

1. Remove the damper assembly from its container and inspect for damage or shortages.
2. Remove the large evaporator access panel.
3. Locate and remove the panel covering the horizontal return air opening. Retain the screws for step 4.
4. Feed the wiring harness into the duct opening and attach the damper to the side of the unit using the screws from step 3 and weatherproof with silicone sealant or other approved method where indicated in figure 1.
5. Connect the plug from the wiring harness to the plug provided inside the evaporator chamber of the unit.
6. Replace the evaporator access panel.

## DETERMINING DAMPER SET POINT

While it is possible to estimate the amount of fresh air by visually adjusting the manual fresh air damper, a more accurate determination can be made using a digital thermometer and the equation below.

$$(To \times OA) + (Tr \times RA) = Tm$$

To = Outdoor air temperature

OA= Percent of outdoor air

Tr = Return air temperature

RA= Percent of return air

Tm= Resulting mixed air temperature

Example:

Fresh air required is 10% outdoor air.

Outdoor air temperature is 60 degrees F.

Return air temperature is 75 degrees F.

$$(0.1 \times 60) + (0.9 \times 75) = \\ 6.0 + 67.5 = 73.5$$

Mixed air temperature will be 73.5 degrees F when the OA is 60 degrees F and the RA is 75 degrees F with 10% outdoor air.

Figure 1

